



(12) **EUROPEAN PATENT APPLICATION**

(88) Date of publication A3:
12.09.2007 Bulletin 2007/37

(51) Int Cl.:
G09G 3/36^(2006.01)

(43) Date of publication A2:
30.11.2005 Bulletin 2005/48

(21) Application number: **05253119.1**

(22) Date of filing: **20.05.2005**

(84) Designated Contracting States:
AT BE BG CH CY CZ DE DK EE ES FI FR GB GR HU IE IS IT LI LT LU MC NL PL PT RO SE SI SK TR
 Designated Extension States:
AL BA HR LV MK YU

(72) Inventor: **Mizumaki, Hidetaka**
Nara-shi, Nara 630-8114 (JP)

(74) Representative: **Brown, Kenneth Richard et al**
R.G.C. Jenkins & Co.
26 Caxton Street
London SW1H 0RJ (GB)

(30) Priority: **25.05.2004 JP 2004154755**

(71) Applicant: **Sharp Kabushiki Kaisha**
Osaka 545-8522 (JP)

(54) **Display device and driving method thereof**

(57) The display device of the invention includes a display panel including a plurality of pixels arranged in a matrix of rows and columns, and switching elements each being connected to a corresponding one of the plurality of pixels; row driving circuits to for each selecting a row in the plurality of pixels by supplying a selection signal to the switching elements; column driving circuits for each supplying a data signal to pixels connected to the switching elements selected with the selection signal;

and a black display signal generation circuit for generating a black display signal for causing the plurality of pixels to perform a black display. The data signal and the black display signal are supplied to each of the plurality of pixels during a period corresponding to one vertical scanning period. The display device further includes a black ratio control signal generation circuit for generating a black ratio control signal defining a ratio between a first period of retaining the data signal and a second period of retaining the black display signal.

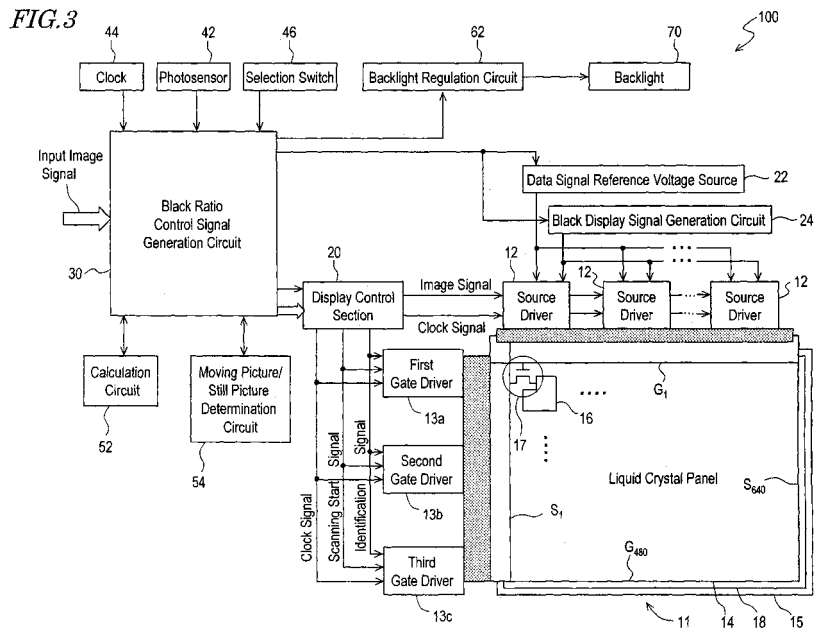



DOCUMENTS CONSIDERED TO BE RELEVANT			
Category	Citation of document with indication, where appropriate, of relevant passages	Relevant to claim	CLASSIFICATION OF THE APPLICATION (IPC)
X	US 2002/003522 A1 (BABA MASAHIRO [JP] ET AL) 10 January 2002 (2002-01-10) * figure 7 * * paragraph [0094] * * paragraph [0118] * * paragraph [0117]; figure 2 * * paragraph [0096] * * paragraph [0121] * * paragraph [0141] * * figure 11 * * paragraph [0131] * * paragraph [0012] *	1-6, 8-16, 18-21	INV. G09G3/36
X	US 2003/122772 A1 (PARK JONG JIN [KR] ET AL) 3 July 2003 (2003-07-03) * figure 1 * * paragraph [0026] - paragraph [0036] *	1,8,10, 11,13, 14,16, 20,21	
X	US 2002/047818 A1 (YAMAMOTO TSUNENORI [JP] ET AL) 25 April 2002 (2002-04-25) * figure 4 * * figure 6 * * paragraph [0051] - paragraph [0054] * * paragraph [0066] - paragraph [0069] *	1,8-10, 13,20,21	TECHNICAL FIELDS SEARCHED (IPC) G09G
X	WO 03/063121 A (MATSUSHITA ELECTRIC IND CO LTD [JP]; KUMAMOTO YASUHIRO [JP]; FUNAMOTO) 31 July 2003 (2003-07-31) * the whole document *	1,7,8, 10,13, 17,20,21	
----- -/--			
The present search report has been drawn up for all claims			
Place of search The Hague		Date of completion of the search 2 August 2007	Examiner Lochhead, Steven
CATEGORY OF CITED DOCUMENTS X : particularly relevant if taken alone Y : particularly relevant if combined with another document of the same category A : technological background O : non-written disclosure P : intermediate document T : theory or principle underlying the invention E : earlier patent document, but published on, or after the filing date D : document cited in the application L : document cited for other reasons & : member of the same patent family, corresponding document			

4
EPO FORM 1503 03.02 (P04C01)



DOCUMENTS CONSIDERED TO BE RELEVANT			
Category	Citation of document with indication, where appropriate, of relevant passages	Relevant to claim	CLASSIFICATION OF THE APPLICATION (IPC)
P,X	-& US 2004/141094 A1 (KUMAMOTO YASUHIRO [JP] ET AL) 22 July 2004 (2004-07-22) * figure 1 * * figure 7 * * paragraph [0044] - paragraph [0046] * * paragraph [0064] * * paragraph [0072] - paragraph [0076] * -----	1,7,8, 10,13, 17,20,21	TECHNICAL FIELDS SEARCHED (IPC)
D,A	JP 2001 060078 A (SHARP KK) 6 March 2001 (2001-03-06) * the whole document *	1,20	
A	& EP 1 061 499 A (SHARP KK [JP]) 20 December 2000 (2000-12-20) * the whole document *	1,20	
A	GB 2 322 219 A (NIPPON ELECTRIC CO [JP]) 19 August 1998 (1998-08-19) * figure 1 * * page 4, line 9 - line 21 *	2,13,14, 16,21	
A	JP 09 175232 A (SANYO ELECTRIC WORKS; NIIGATA ENGINEERING CO LTD) 8 July 1997 (1997-07-08) * abstract *	13,14, 16,18, 19,21	
D,A	JP 2002 108305 A (MATSUSHITA ELECTRIC IND CO LTD) 10 April 2002 (2002-04-10) * abstract *	13-16,21	
The present search report has been drawn up for all claims			
Place of search The Hague		Date of completion of the search 2 August 2007	Examiner Lochhead, Steven
CATEGORY OF CITED DOCUMENTS X : particularly relevant if taken alone Y : particularly relevant if combined with another document of the same category A : technological background O : non-written disclosure P : intermediate document		T : theory or principle underlying the invention E : earlier patent document, but published on, or after the filing date D : document cited in the application L : document cited for other reasons & : member of the same patent family, corresponding document	

4
EPO FORM 1503 03/02 (P04C01)

**ANNEX TO THE EUROPEAN SEARCH REPORT
ON EUROPEAN PATENT APPLICATION NO.**

EP 05 25 3119

This annex lists the patent family members relating to the patent documents cited in the above-mentioned European search report. The members are as contained in the European Patent Office EDP file on
The European Patent Office is in no way liable for these particulars which are merely given for the purpose of information.

02-08-2007

Patent document cited in search report	Publication date	Patent family member(s)	Publication date
US 2002003522 A1	10-01-2002	KR 20020005489 A	17-01-2002
US 2003122772 A1	03-07-2003	CN 1430200 A KR 20030059551 A	16-07-2003 10-07-2003
US 2002047818 A1	25-04-2002	JP 3747768 B2 JP 2001331156 A KR 20010091912 A TW 508557 B	22-02-2006 30-11-2001 23-10-2001 01-11-2002
WO 03063121 A	31-07-2003	CN 1496546 A EP 1471489 A1 US 2004141094 A1	12-05-2004 27-10-2004 22-07-2004
US 2004141094 A1	22-07-2004	CN 1496546 A EP 1471489 A1 WO 03063121 A1	12-05-2004 27-10-2004 31-07-2003
JP 2001060078 A	06-03-2001	CN 1279459 A CN 1560671 A EP 1061499 A2 JP 3556150 B2 KR 20010007353 A TW 432348 B US 2005237294 A1 US 6937224 B1	10-01-2001 05-01-2005 20-12-2000 18-08-2004 26-01-2001 01-05-2001 27-10-2005 30-08-2005
EP 1061499 A	20-12-2000	CN 1279459 A CN 1560671 A JP 3556150 B2 JP 2001060078 A KR 20010007353 A TW 432348 B US 2005237294 A1 US 6937224 B1	10-01-2001 05-01-2005 18-08-2004 06-03-2001 26-01-2001 01-05-2001 27-10-2005 30-08-2005
GB 2322219 A	19-08-1998	CN 1191446 A JP 2891955 B2 JP 10228010 A US 6078302 A	26-08-1998 17-05-1999 25-08-1998 20-06-2000
JP 9175232 A	08-07-1997	NONE	
JP 2002108305 A	10-04-2002	JP 3487278 B2	13-01-2004

EPO FORM P0459

For more details about this annex : see Official Journal of the European Patent Office, No. 12/82