



US00D668986S

(12) **United States Design Patent**
Friedman

(10) **Patent No.:** **US D668,986 S**

(45) **Date of Patent:** **** Oct. 16, 2012**

(54) **EARRING**

(76) Inventor: **David Friedman**, Lawrence, NY (US)

(**) Term: **14 Years**

(21) Appl. No.: **29/382,665**

(22) Filed: **Jan. 6, 2011**

(51) **LOC (9) Cl.** **11-01**

(52) **U.S. Cl.** **D11/41**

(58) **Field of Classification Search** D11/40-48,
D11/1, 2, 3, 26-39, 79; 63/12, 13
See application file for complete search history.

(56) **References Cited**

U.S. PATENT DOCUMENTS

| | | | | | | |
|-----------|---|---|---------|--------------------|-------|--------|
| D142,234 | S | * | 8/1945 | Subrink | | D11/26 |
| D291,544 | S | * | 8/1987 | Wagner | | D11/41 |
| 4,996,851 | A | * | 3/1991 | Schinzinger et al. | | 63/26 |
| D375,703 | S | * | 11/1996 | Lowe et al. | | D11/88 |
| D650,304 | S | * | 12/2011 | Tanory, Jr. | | D11/40 |

OTHER PUBLICATIONS

http://www.wayfair.com/Ayana-Jewelry-Chandi-Court-Sterling-Silver-Stud-Hexagonal-Earrings-AJ-1213E-JYJ1022.html?refid=FR49-JYJ1022.*

http://www.etsy.com/listing/93998447/hexagonal-candy-earrings?utm_source=googleproduct&utm_medium=syndication&utm_campaign=GPS.*
http://www.goantiques.com/scripts/images/id,904659.html.*

* cited by examiner

Primary Examiner — Cathron Brooks

Assistant Examiner — Melanie Pellegrini

(74) *Attorney, Agent, or Firm* — Bernard Malina

(57) **CLAIM**

The ornamental design for an earring or similar articles, as shown and described.

DESCRIPTION

FIG. 1 is a top, front and left side perspective view; FIG. 2 is a top plan view thereof, the bottom view being identical; FIG. 3 is a front elevational view thereof; FIG. 4 is a right side elevational view thereof, the left side being a mirror image; and, FIG. 5 is a rear elevational view thereof. The broken lines shown in the drawings represent portions of the earring that form no part of the claimed design.

1 Claim, 2 Drawing Sheets

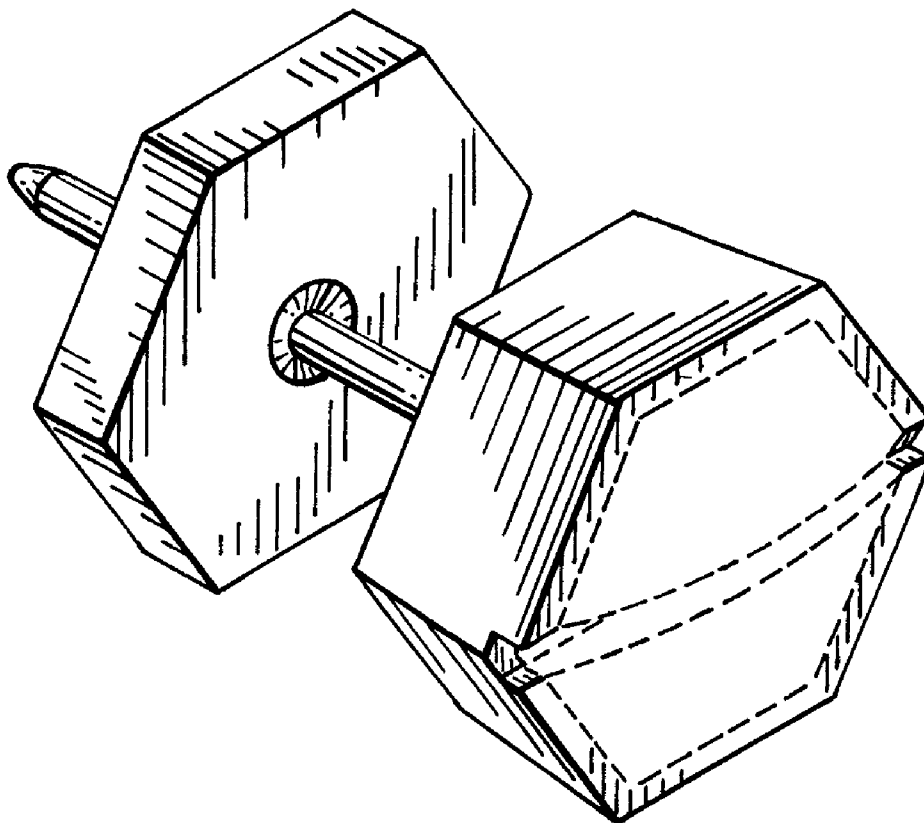

FIG. 1

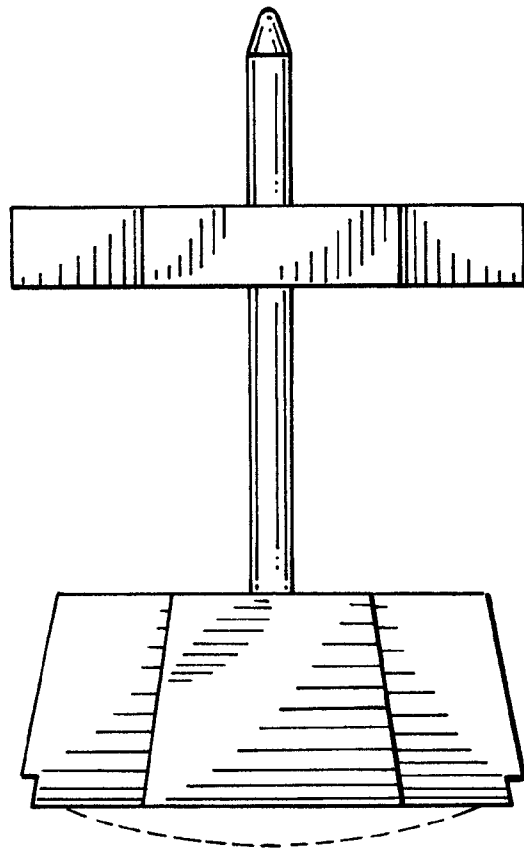
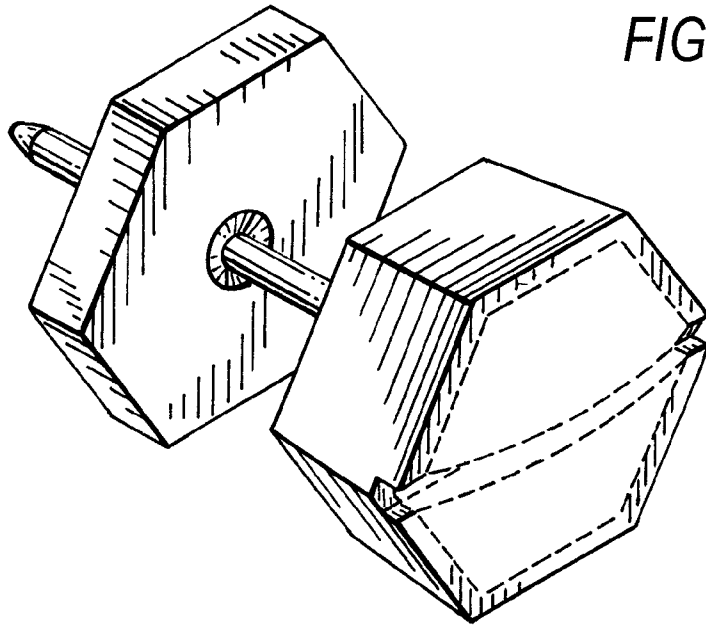

FIG. 2

FIG. 4

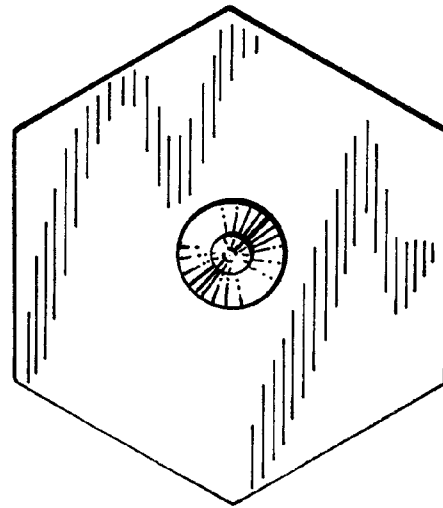
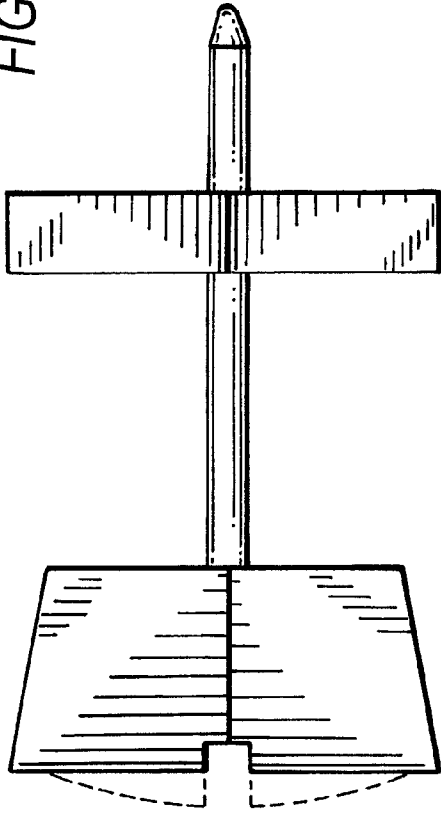

FIG. 5

FIG. 3

