

*T. J. Nottingham,*

*Lubricator.*

*No. 110,156.*

*Patented Dec. 13, 1870.*

**Fig. 1**

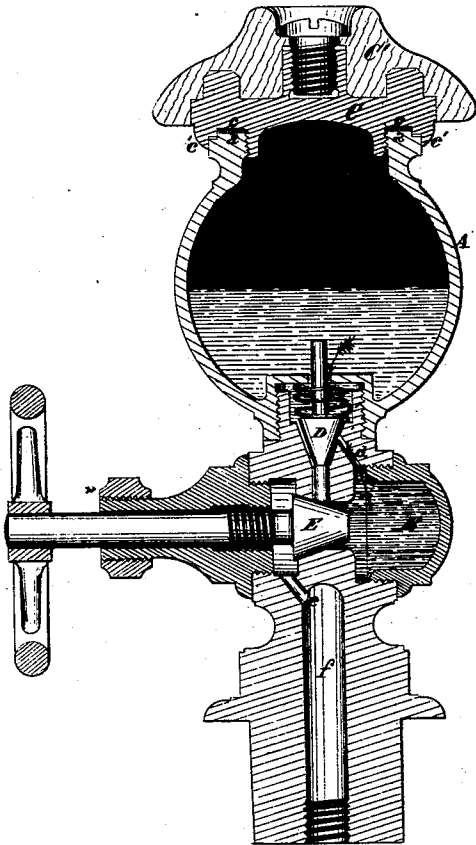

**Fig. 2**

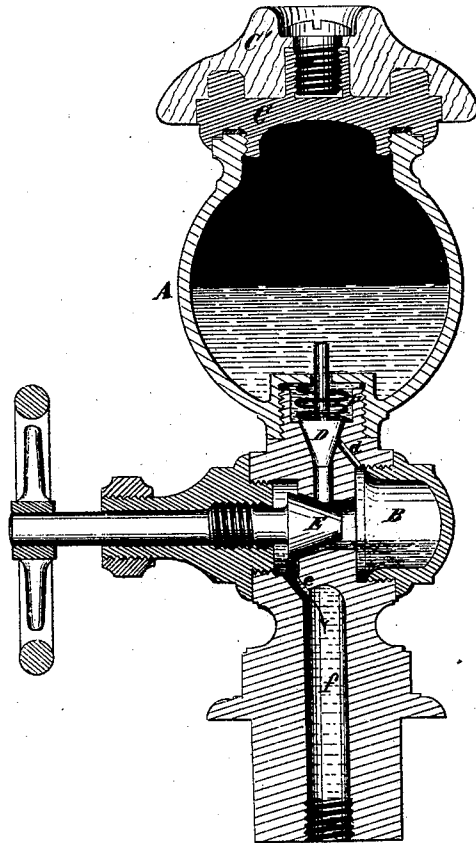

**Attest**

*Wm. Henry Millward  
E. S. Lippman*

**Inventor**

*Thos. J. Nottingham  
By W. Millward  
Attorney*

# United States Patent Office.

THOMAS J. NOTTINGHAM, OF CINCINNATI, OHIO.

Letters Patent No. 110,156, dated December 13, 1870.

## IMPROVEMENT IN LUBRICATORS.

The Schedule referred to in these Letters Patent and making part of the same.

### To all whom it may concern:

Be it known that I, THOMAS J. NOTTINGHAM, of Cincinnati, Hamilton county, State of Ohio, have invented a certain new and useful Improvement in Tallow-Lubricators; and I do hereby declare the following to be a full, clear, and exact description thereof, reference being had to the accompanying drawing making part of this specification.

### Nature and Objects of Invention.

My invention consists of a tallow-lubricator, which is provided with a chamber between the cup and discharge-orifice for receiving a limited charge of tallow, this chamber being governed for supply and discharge by two valves, each arranged to be closed when the other is open.

### Description of the Accompanying Drawing.

Figure 1 is an axial section of my lubricator, showing the charging-chamber in communication with the cup or general receiver.

Figure 2 is a similar section, showing the charging-chamber in communication with the discharge-orifice.

### General Description.

A is the cup proper or general receiver for the tallow, and

B, the charging-chamber.

C is the cap of the cup.

It is constructed with an annular groove, *c*, for the reception of the gasket, which groove is sufficiently deep to permit the annular projection *a* on the cup to enter it, and thus permit the cup, in expanding under heat, to tighten the joint.

The cover is also provided with an annular lip, *c'*, to fit over the edge of the cup for the purpose of limiting the expansion of the cup under heat, and thus, in addition to the device *a c*, causing the cup to make its own joint when hot.

The cap or cover C is also fitted with the customary wooden top C'.

D is a common conical valve, designed to govern the flow of tallow to the chamber B; and

E, a conical valve to govern the discharge of tallow from the chamber B to the part to be lubricated.

The port *d* conveys the tallow from the cup A to the chamber B, and the port *e* conducts it to the discharge-orifice *f*.

The valve D is forced to its seat by the spiral spring F, which is sufficiently strong to resist the pressure of steam below the valve, and it is raised by the valve E, whose conical face impinges against the stem of the valve D and thus forces it from its seat.

### Operation.

When the valve E is closed, the valve D being forced from its seat and thus opened, the tallow is permitted to run from the cup A into the chamber B and fill the same.

When it is necessary to discharge the tallow the valve E is opened and the valve D thus permitted to fall. The communication is then cut off from the chamber B to the cup A, but the chamber B freely discharges its contents into the discharge-pipe *f*.

### Claim.

I claim—

In the described connection with the chambers A B, the valves D E, operating as described, and for the purpose specified.

In testimony of which invention I hereunto set my hand.

THOS. J. NOTTINGHAM.

Witnesses:

J. L. WARTMANN,  
HENRY MILLWARD.