

(No Model.)

2 Sheets—Sheet 1.

L. F. VOISARD.
DUPLEX STEAM ENGINE.

No. 526,645.

Patented Sept. 25, 1894.

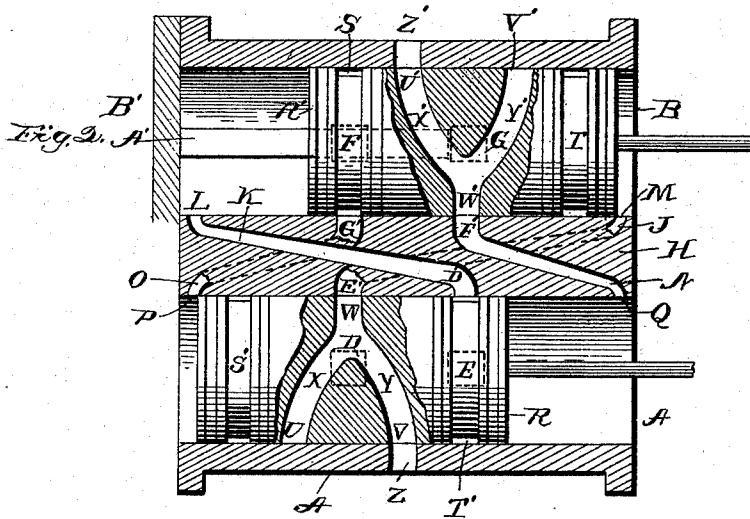
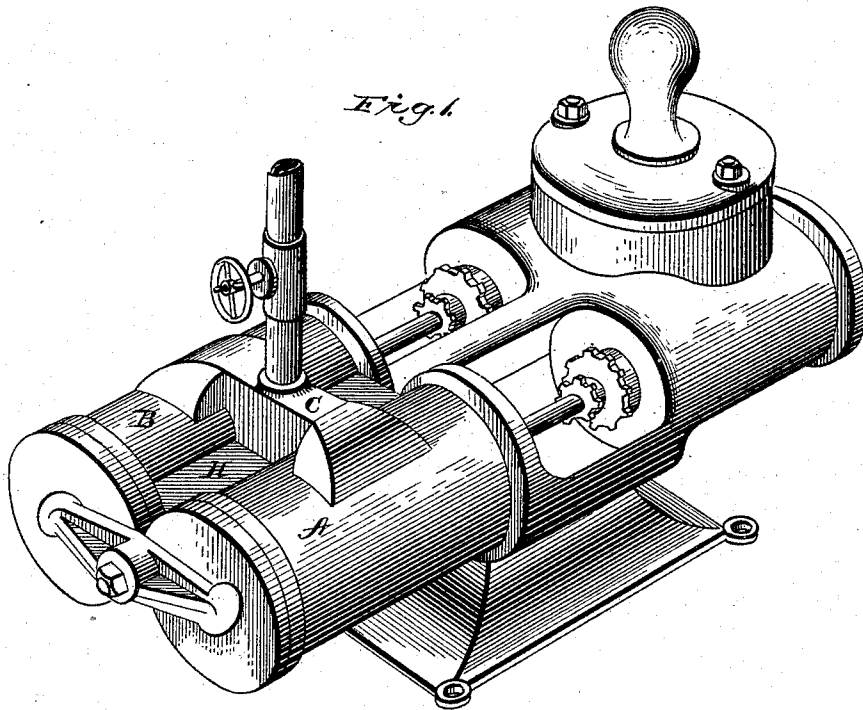

Witnesses:
J. M. Fowler Jr.
Geo. H. Coars

Inventor:
Louis F. Voisard
H. K. Miller, Atty
By Paul & Co
Associate Attorney.

(No Model.)

2 Sheets—Sheet 2.

L. F. VOISARD.
DUPLEX STEAM ENGINE.

No. 526,645.

Patented Sept. 25, 1894.

Fig. 3.

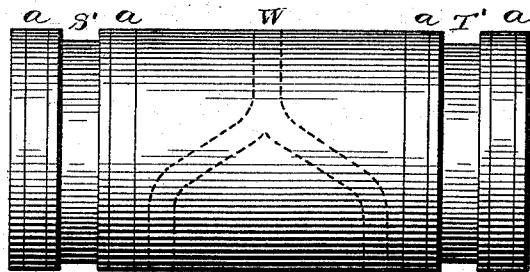
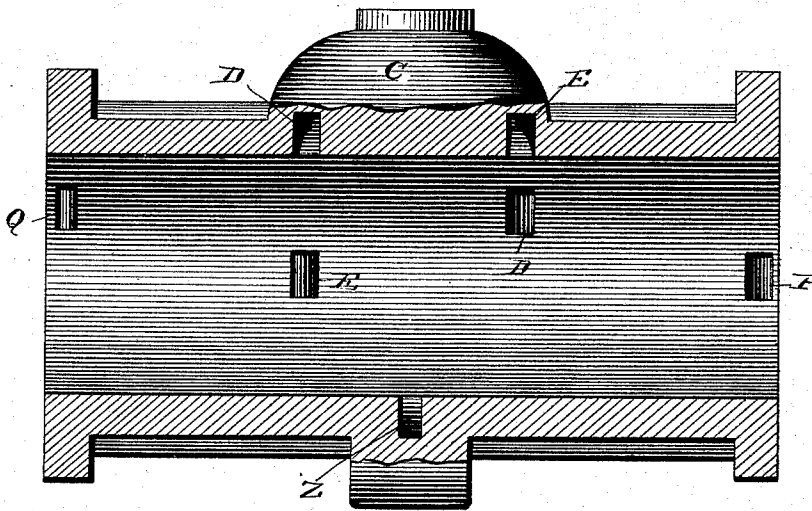

Fig. 4.



Witnesses:
J. M. Fowler Jr.
Geo. H. Evans

Inventor:
Louis F. Voisard
W. K. Miller & Co.
By Benj. G. Cowell
Associate Attorney.

UNITED STATES PATENT OFFICE.

LOUIS F. VOISARD, OF LOUISVILLE, ASSIGNOR OF ONE-HALF TO EDGAR E. MILLER, OF CLEVELAND, OHIO.

DUPLEX STEAM-ENGINE.

SPECIFICATION forming part of Letters Patent No. 526,645, dated September 25, 1894.

Application filed January 6, 1894. Serial No. 496,015. (No model.)

To all whom it may concern:

Be it known that I, LOUIS F. VOISARD, a citizen of the United States, and a resident of Louisville, county of Stark, State of Ohio, have invented a new and useful Improvement in Duplex Steam-Engines, of which the following is a full, clear, and exact description, reference being had to the accompanying drawings, making part of this specification.

My invention relates to an improvement in duplex steam engines for duplex pumps or other purposes, and consists of certain features of construction and combination of parts as will be hereinafter described and claimed.

Figure 1 of the accompanying drawings is a view in perspective of my invention as applied to a duplex pump. Fig. 2, is a diagrammatic view of the cylinders, pistons, ports and steam passages. Fig. 3, is a side view of one of the pistons. Fig. 4, is a vertical longitudinal sectional view through one of the cylinders.

Referring to Fig. 1, A and B represent the steam cylinders, C a connecting pipe, having therein ports D and E, that connect with cylinder A, and similar ports F and G at the opposite end of pipe C, connect with the cylinder B. As the cylinder and piston heads are duplicated, a description of one cylinder and one piston will serve for the other.

In the web portion H that connects the cylinders A, B, are provided steam conduits or passage ways J and K, that lead from ports D and E, in cylinder A, to ports L and M in cylinder B, and cross in their passage leading to the opposite ends of the cylinder, and passage ways N and O, that lead from ports F', G', in cylinder B to ports P and Q, in cylinder A. These latter mentioned passages do not cross each other as is shown in diagram Fig. 2.

The combined piston heads and valves R and R', are formed substantially as shown in Figs. 2 and 3, having near their end portions recesses S' and T', and S and T, the recesses S' and T' in piston R forming passages from the steam ports D and E to the ports D' and E', in the side of the cylinder, and in the body portion exhaust ports U, V, W, connected by branch passages X, Y, while the recesses S and

T in the piston R' form passages from the steam ports F and G to the ports G' F' in the side of the cylinder and in the body of the piston exhaust ports U' V' W' connected by branch passages X' Y'. These ports as the pistons are moved longitudinally in the cylinders, register with the steam ports D', E', F', G', and exhaust ports Z, situated in the exhaust pipe, that is under and connects the cylinders A and B, similar to the pipe C, on the top of the cylinder.

Packing rings as *a* are placed in recesses on each side of the recesses S T, and S' T' to prevent the escape of steam.

Referring to Fig. 2, piston R' is represented as having completed its stroke in cylinder B, exhaust port M, open through passage J, to exhaust port W in piston, thence through passage V to exhaust Z. Recess S is now in register with steam port F, communicating with left hand end of cylinder A, through which steam will pass *via* passage O and port P, and exhausted through passage N to port W', thence through passage U', to exhaust port Z'. The piston will be driven by the steam so admitted toward the right hand end of cylinder A, bringing exhaust port W in register with port D', and recess S' in register with steam port E', in which position steam will pass from the left hand end of cylinder B, through passages K to exhaust port W and port U, to exhaust Z, while steam is being admitted from recess S' through passage J to the right hand end of cylinder B, to drive the piston toward the left hand, which movement will bring recess T in register with steam port G, which will deliver steam through passage N, to the right hand end of cylinder A to reverse the movement of piston R, and so on will the alternate movement of the pistons be continued, so long as a sufficient amount of steam is provided.

For the purposes of this application, I have shown annular recesses in the pistons R and R', but if preferred they may be reduced to depressions sufficiently long to cover or take in the ports D, E, in the side of the cylinder; and to hold the pistons against rotary movement and hold the exhaust ports in line to register with the ports in the cylinder, there is provided in the left hand ends of the pis-

tons, an angular aperture in which a bar A' of similar form secured to the cylinder head B', will pass.

5 Having thus fully described the nature and object of my invention, what I claim is—

1. The combination with a pair of twin cylinders of steam passages leading from the middle portion of one cylinder to the end portion of the other, and a piston head having at its end portion recesses that serve as passages or connections between the steam ports D and E, and F and G, and the exhaust passage leading through the central portion of the piston, having branches that alternately register with the exhaust port Z, substantially as described and for the purpose set forth.

2. The combination with twin cylinders placed side by side, of a connecting pipe portion or steam chest C, of the steam ports D and E, communicating with one of the cylinders and similar ports F and G, communi-

cating with the other cylinder, communicating steam passages between the cylinders, and a combined piston head and valve, whereby steam is directed to the cylinders, and an outlet or exhaust passage, substantially as described and for the purpose set forth.

3. The combination with a pair of cylinders placed side by side and having communicating steam passages, and ports W W', U V, and U' V', passages S and T S' T' in the pistons R R' adapted to direct or control the flow of steam and means for preventing the rotation of said pistons, substantially as herein described.

In testimony whereof I have hereunto set my hand this 14th day of December, A. D. 1893.

LOUIS F. VOISARD.

Witnesses:

W. K. MILLER,
BURT A. MILLER.