



(86) **Date de dépôt PCT/PCT Filing Date:** 2016/04/19  
 (87) **Date publication PCT/PCT Publication Date:** 2016/11/03  
 (45) **Date de délivrance/Issue Date:** 2020/06/09  
 (85) **Entrée phase nationale/National Entry:** 2017/10/25  
 (86) **N° demande PCT/PCT Application No.:** EP 2016/058646  
 (87) **N° publication PCT/PCT Publication No.:** 2016/173889  
 (30) **Priorité/Priority:** 2015/04/27 (EP15165250.0)

(51) **Cl.Int./Int.Cl. H04R 5/04** (2006.01),  
**H04R 1/40** (2006.01), **H04S 5/00** (2006.01)

(72) **Inventeurs/Inventors:**  
 FALLER, CHRISTOF, CH;  
 SCHMIDT, MARKUS, DE;  
 WALTHER, ANDREAS, DE;  
 BORSS, CHRISTIAN, DE;  
 SAARI, VILLE, DE;  
 GOETZ, PHILIPP, DE

(73) **Propriétaire/Owner:**  
 FRAUNHOFER-GESELLSCHAFT ZUR FOERDERUNG  
 DER ANGEWANDTEN FORSCHUNG E.V., DE

(74) **Agent:** BORDEN LADNER GERVAIS LLP

(54) **Titre : SYSTEME ACOUSTIQUE**  
 (54) **Title: SOUND SYSTEM**

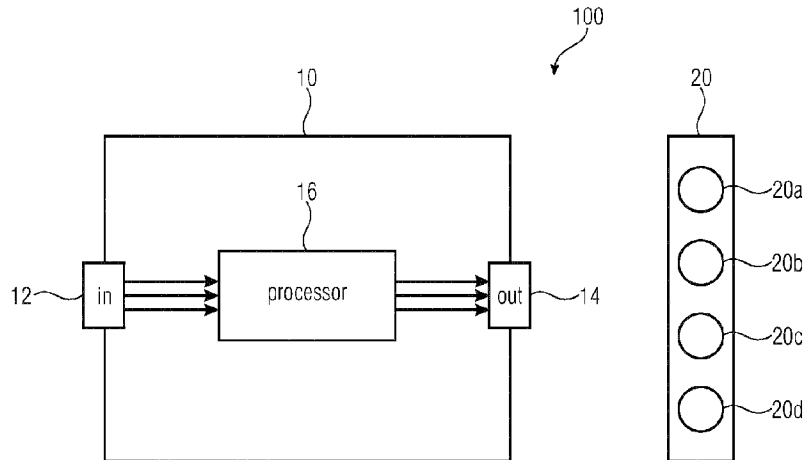

(57) **Abrégé/Abstract:**

A calculation unit for a sound system comprises input means, a processor and output means. The input means have the purpose to receive an audio stream to be reproduced using the sound system. The output means has the purpose to control the sound system based on a first and a second plurality of individual audio signals. The processor is configured to calculate the first plurality of audio signals such that beamforming is performed by the array and to calculate the second plurality of individual audio signals to perform, using the sound system, direct sound suppression such that sound is canceled towards a listening direction. Furthermore, the processor filters at least the second plurality using a second passband characteristic comprising a second portion of the entire frequency range.

(12) INTERNATIONAL APPLICATION PUBLISHED UNDER THE PATENT COOPERATION TREATY (PCT)

(19) World Intellectual Property  
Organization  
International Bureau(10) International Publication Number  
**WO 2016/173889 A1**(43) International Publication Date  
3 November 2016 (03.11.2016)

- (51) **International Patent Classification:**  
*H04R 5/02* (2006.01)    *H04S 5/00* (2006.01)  
*H04R 5/04* (2006.01)    *H04R 1/40* (2006.01)
- (21) **International Application Number:** PCT/EP2016/058646
- (22) **International Filing Date:** 19 April 2016 (19.04.2016)
- (25) **Filing Language:** English
- (26) **Publication Language:** English
- (30) **Priority Data:**  
15165250.0    27 April 2015 (27.04.2015)    EP
- (71) **Applicant:** FRAUNHOFER-GESELLSCHAFT ZUR FÖRDERUNG DER ANGEWANDTEN FORSCHUNG E.V. [DE/DE]; Hansastraße 27c, 80686 München (DE).
- (72) **Inventors:** FALLER, Christof; Stationsstraße 26, 8606 Greifensee (CH). SCHMIDT, Markus; Flöhbergweg 8, 79541 Lörrach (DE). WALTHER, Andreas; Merkurweg 13, 90537 Feucht (DE). BORSS, Christian; Franzosenweg 40, 91058 Erlangen (DE). SAARI, Ville; Rollnerstr. 66, 90408 Nürnberg (DE). GÖTZ, Philipp; Stresemannstr. 76, 10963 Berlin (DE).
- (74) **Agent:** SCHENK, Markus; Schoppe, Zimmermann, Stöckeler, Zinkler, Schenk & Partner mbB, Radlkofenstr.2, 81373 München (DE).
- (81) **Designated States** (*unless otherwise indicated, for every kind of national protection available*): AE, AG, AL, AM, AO, AT, AU, AZ, BA, BB, BG, BH, BN, BR, BW, BY, BZ, CA, CH, CL, CN, CO, CR, CU, CZ, DE, DK, DM, DO, DZ, EC, EE, EG, ES, FI, GB, GD, GE, GH, GM, GT, HN, HR, HU, ID, IL, IN, IR, IS, JP, KE, KG, KN, KP, KR, KZ, LA, LC, LK, LR, LS, LU, LY, MA, MD, ME, MG, MK, MN, MW, MX, MY, MZ, NA, NG, NI, NO, NZ, OM, PA, PE, PG, PH, PL, PT, QA, RO, RS, RU, RW, SA, SC, SD, SE, SG, SK, SL, SM, ST, SV, SY, TH, TJ, TM, TN, TR, TT, TZ, UA, UG, US, UZ, VC, VN, ZA, ZM, ZW.
- (84) **Designated States** (*unless otherwise indicated, for every kind of regional protection available*): ARIPO (BW, GH, GM, KE, LR, LS, MW, MZ, NA, RW, SD, SL, ST, SZ, TZ, UG, ZM, ZW), Eurasian (AM, AZ, BY, KG, KZ, RU, TJ, TM), European (AL, AT, BE, BG, CH, CY, CZ, DE, DK, EE, ES, FI, FR, GB, GR, HR, HU, IE, IS, IT, LT, LU, LV, MC, MK, MT, NL, NO, PL, PT, RO, RS, SE, SI, SK, SM, TR), OAPI (BF, BJ, CF, CG, CI, CM, GA, GN, GQ, GW, KM, ML, MR, NE, SN, TD, TG).

**Published:**

— with international search report (Art. 21(3))

(54) **Title:** SOUND SYSTEM

FIG 1

(57) **Abstract:** A calculation unit for a sound system comprises input means, a processor and output means. The input means have the purpose to receive an audio stream to be reproduced using the sound system. The output means has the purpose to control the sound system based on a first and a second plurality of individual audio signals. The processor is configured to calculate the first plurality of audio signals such that beamforming is performed by the array and to calculate the second plurality of individual audio signals to perform, using the sound system, direct sound suppression such that sound is canceled towards a listening direction. Furthermore, the processor filters at least the second plurality using a second passband characteristic comprising a second portion of the entire frequency range.

## Sound system

### Description

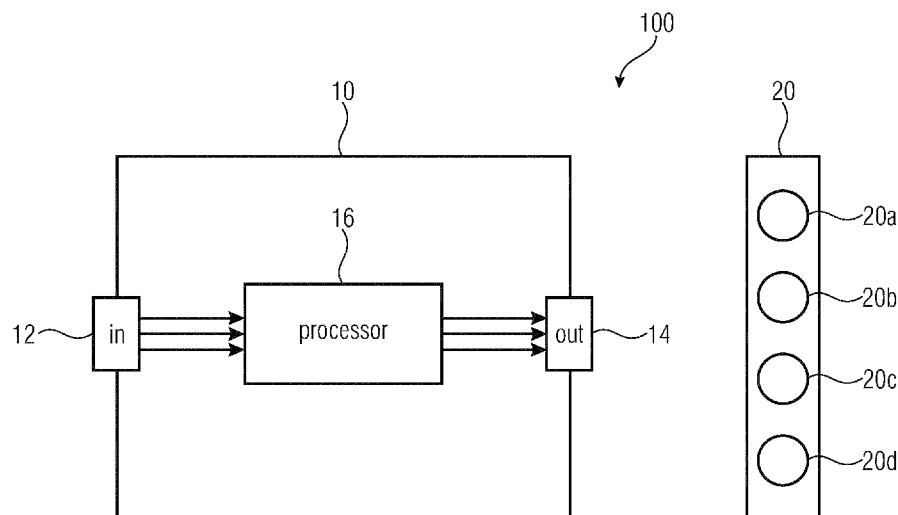
5

Embodiments of the present invention refer to a calculation unit for a sound system, to a corresponding method for calculating a sound reproduction and to a sound system.

10 For sound reproduction, especially movie sound reproduction, there are different kinds of systems which differ with regard to their complexity and reproduction quality. The reference for movie sound is the cinema. Cinemas provide multi-channel surround sound, with loudspeakers installed not only in front at the screen, but additionally on the sides and rear. The side and rear loudspeakers enable an enveloping surround sound.

15 For the home, so-called home cinema systems usually feature five loudspeakers and a subwoofer. Three of the loudspeakers are in front and two are on the side/rear. The side/rear loudspeakers often pose a problem: People will often rather be without them to avoid not only visually distracting loudspeakers in the rear, but also the corresponding cabling.

20

An alternative to home cinema systems are soundbars. Many variations of soundbars exist on the market. The most sophisticated soundbars not only enhance the sound spatially, but form beams to project the sound signals to the side/rear, with the help of reflecting walls. In this case, true surround with a sound perceivable from side/rear is  
25 reproduced without surround speakers.

A soundbar projecting the sound channels to the side/rear comprises a loudspeaker array which projects at least one channel to the side/rear by means of beamforming, e.g. a delay and sum beamformer. A limitation of delay and sum beamformers is that the  
30 aperture of the array has to be at least of the size of order of magnitude of the wavelength of a sound frequency to be emitted. If the array is small compared to the wavelength, no directive beam can be formed.

For example, when a 1.2 m long soundbar emits sound at 200 Hz (wavelength 1.7 m), no  
35 beam with high directivity can be formed. Consequently, soundbars can only effectively project sound to side/rear at medium to high frequencies. Low frequencies will be

reproduced from the front, since projection over walls requires very high directivity (such that only a very low level of sound is reaching the listeners directly, while most of the sound is reaching the listeners via a wall reflected beam).

5 The US Patent US 8,477,951 discloses a loudspeaker array reproduction system that improves the stereo effect of middle and low frequency signals through the use of a psychoacoustic model. The input signal is split, and one part for which beamforming is not performed, is reproduced using virtualization techniques based on HRTF processing, the other part is processed using beamforming techniques. Further audio systems comprising a plurality of channels which feature a loudspeaker array are  
10 disclosed by the US Patent Application US 2005/0089182 and the US Patent US 5,953,432.

The Patent US 8,189,795 discloses a processing for use of the loudspeaker array, where high and low frequency bands are reproduced in different ways. While the high-frequency part is played back using beamforming techniques, the low frequency part is further divided into correlated and uncorrelated parts,  
15 which are then played back by further non-arrayed loudspeakers with different directivity.

The US Patent US 8,150,068 discloses an array playback system for surround sound input, that makes use of a frequency division into high and low frequency parts. The higher frequency is reproduced using the loudspeaker array for beamforming and utilizing the wall reflections. The lower frequency part of the  
20 different input channels are summed into signals which are output over one or more woofer speakers.

All above teachings have the drawback of high complexity and/or limited quality of surround reproduction. Therefore, there is a need for an improved approach.

25 The objective of the invention is to provide a concept for improving surround sound reproduction by use of a sound system.

An embodiment of the invention provides a calculation unit for a sound system which comprises at least an array having a plurality of transducers. The calculation unit comprises input means for receiving an  
30 audio stream to be reproduced using the array, a processor and output means for controlling the sound system/the array. The audio stream

has a certain frequency range, e.g. from 20 Hz to 20 kHz. The processor is configured to calculate a first plurality of individual audio signals for the transducers of the array such that beamforming is performed by the array. Furthermore, the processor is configured to calculate the second plurality of individual audio signals for the transducers of the sound system to perform, using the transducers, so-called direct sound suppression such that sound is canceled towards a listening direction. This may be realized by a technique called dipoling (e.g. applying phase shifted signals to transducers arranged spaced apart from each other) and/or by a technique called sound cancelation (e.g. comprising a manipulation or correction of the beamforming), performed by the sound system. Here, the first plurality of individual audio signals comprises a frequency range corresponding to a first portion of the entire frequency range of the audio stream (e.g. a frequency range from 400 Hz to 2000 Hz or from 500 Hz to 5000 Hz or the entire frequency range of the audio stream). The processor filters the second plurality of individual audio signals using a second passband characteristic (e.g. from 100 Hz to 500 Hz or from 200 Hz to 400 Hz), i.e., the second passband characteristic comprises a second portion of the entire frequency range of the audio stream. In general, the second portion differs from the first portion.

The teachings disclosed herein are based on the knowledge that the quality of surround effects generated using beamforming varies over the entire frequency range. In detail, the beamforming is limited within certain frequencies; e.g. at low frequencies, beams cannot be projected via walls to the listener, they will always reach the listeners with substantial level directly. Therefore, according to the teachings disclosed herein, this certain (problematic) frequencies are reproduced by another technique, called direct sound suppression comprising dipoling, or alternatively by using sound cancelation within these (problematic) frequencies, both enabling to generate a radiation pattern of the playback device having a sound minimum (at least within some frequencies) in the direction of a listener or a listening area.

Dipoling is a technique according to which the sound is canceled in a certain area or direction by using at least two transducers that are driven by signals with differing phase. Sound cancelation is a technique which may comprise a further beamforming reproduction performed in that way that the (first) beamforming within the problematic frequencies is corrected. The further beamforming reproduction comprises especially the (problematic) frequencies for which the reproduction by the first beamforming performance does not suffice. The sound cancelation and/or the dipoling enable to

improve the reproduction, especially within the problematic frequencies and, thus, the entire reproduction without increasing the complexity, since the two techniques are applicable by use of the same soundbar.

- 5 According to an aspect of the invention the sound cancelation is used to perform sound cancelation of the frequencies and in the area to which the sound signal has misleadingly been emitted by the first beamforming reproduction. For example, low frequencies, which are typically emitted by a soundbar performing beamforming in a direct manner can be canceled in this area due to a second beam.

10

According to another aspect, these frequencies, e.g. low frequencies, can be reproduced using dipoling, e.g. via the transducers of the soundbar which are arranged furthest from each other such that the sound is emitted in the two directions. Here, it may be, according to embodiments, beneficial to limit the frequency range in which beamforming is preformed (by means of filtering). Consequently, the transducers of the soundbar perform beamforming within a first frequency range which does not comprise problematic frequencies and uses at least two transducers for outputting the problematic, e.g. lower frequencies in a dipole manner.

15

- 20 According to an embodiment, the dipoling is performed by providing at least two individual audio signals of the second plurality of individual audio signals for two different transducers or two different groups of transducers in a phase-shifted manner, for example, phase-shifted by 180°.

- 25 According to a further embodiment, a third bandwidth, e.g. a bandwidth having a higher frequency than the first portion of the frequency range, may be reproduced using the above described dipoling techniques.

- It should be noted that the first plurality of individual audio signals and the second plurality of individual audio signals may be used for controlling different transducers. According to a preferred embodiment, the first plurality of individual audio signals may be used to control the entire array, wherein the second plurality is used to control just a (real) subset, e.g. two transducers of the arrays. Here, it is, especially with respect to the reproduction of low frequencies in a dipole manner, beneficial to use or to control the transducers which are arranged furthest from each other.
- 30
- 35

According to an embodiment, the calculation of the first plurality of individual audio signals  $x_i$  may be based on the formula

$$x_i(t) = \text{HPF}\{s(t + \tau_i)\}, \text{ or the formula}$$

5

$$x_i(t) = \text{HPF}\{s(t + i * \tau - N * \tau)\},$$

wherein HPF complies with the first passband characteristic,  $\tau / \tau_i$  with a delay and N with the number of transducers of the array, and wherein the calculation of the second plurality of individual audio signals  $x_i$  and  $x_N$  is based on the formula

10

$$x_i(t) = \text{LPF}\{s(t)\}$$

$$x_N(t) = -\text{LPF}\{s(t)\},$$

15

wherein LPF complies with the second passband characteristic.

A further embodiment provides a sound system comprising an above discussed calculator and the corresponding array. The array may, according to further embodiments, have separate transducers, which may be used for dipoling, i.e. are controlled using the second plurality of individual audio signals.

20

A further embodiment provides the corresponding method for calculating a sound reproduction for a sound system.

25

Embodiments of the present invention will be discussed referring to the enclosed figures, wherein,

Fig. 1 shows a schematic block diagram of a sound system with calculation unit according to a first embodiment;

30

Figs. 2a, 2b show a schematic array for illustrating the principle of beamforming and dipoling;

- Fig. 3a shows a schematic diagram in the frequency view illustrating a combination of beamforming and dipoling;
- 5 Fig. 3b shows an exemplary soundbar used in combination with the embodiment of Fig. 3a;
- Fig. 4a, 4b illustrate an embodiment of an array in which three dipoles and one beam is formed with corresponding frequency range illustration;
- 10 Fig. 4c, 4d illustrate an embodiment of an array in which three dipoles and one beam is formed, of which two side orientated dipoles operate in a same frequency range, with corresponding frequency range illustration;
- Fig. 5a, 5b illustrate an embodiment of an array comprising separate enclosed  
15 loudspeakers extending the frequency range for beamforming;
- Fig. 5c, 5d illustrate an embodiment of an array comprising separate enclosed loudspeakers using side-orientated dipoles;
- 20 Fig. 6a shows an embodiment of an array comprising transducers of different sizes;
- Fig. 6b shows an embodiment of an array comprising transducers of different  
25 sizes;
- Fig. 7 shows a schematic arrangement of loudspeakers around a screen;
- Fig. 8 shows a schematic block diagram of a calculation unit for a sound system enabling beamforming with sound cancelation; and  
30
- Fig. 9a to 9c shows schematic diagrams illustrating the directivity of a beamformer wherein beamforming is performed using different soundbar control methods.

Embodiments of the present invention will be discussed in detail below referring to the figures. Reference numbers are provided to objects having the same or an identical function. Therefore, the description thereof is interchangeable or mutually applicable.

- 5 Fig. 1 shows a calculation unit 10 for a sound system 100, here a soundbar system. In this embodiment, the sound system 100 comprises at least an array 20 (soundbar) having a plurality of transducers 20a to 20d. The calculation unit 10 comprises input means 12, a processor 16 and output means 14 for controlling the sound system 100.
- 10 An audio stream (e.g. mono/stereo signals or a multi-channel audio stream like common surround sound data or wave field synthesis data) is received via the input means 12, processed by the processor 16 and, dependent on the processing, at least a first plurality of individual audio signals and a second plurality of individual audio signals are output via the output means 14 (e.g. amplification stages) in order to control the transducers 20a to
- 15 20d of the sound system 20.

The processor 16 performs a calculation of a first beamforming reproduction (cf. first plurality of individual audio signals). This first beamforming reproduction enables good surround effects in a limited portion of the entire frequency range (e.g. comprising medium

20 frequencies from 100/200Hz to 400/600 Hz). Particularly in some portions, which will be referred to as second portion or "problematic" portion, the reproduction is poor. Therefore, the processor calculates a second plurality of individual audio signals enabling a correct (beamforming) reproduction within this second portion at least at the listening position. Note, that the first plurality of individual audio signals and the second plurality of individual

25 audio signals may be used to control the same transducers, wherein they are different with regard to the comprised frequency ranges.

For example: Typically low frequency ranges are the problematic frequency ranges. Therefore, the second portion of the entire frequency range typically comprises these

30 frequencies, e.g. below 200 Hz or 100Hz. Dependent on the reproduction technique of the second portion; the first portion may comprise the frequencies above the second portion or may comprise the frequencies of the second portion and the frequencies above the second portion. In order to enable this frequency split, the processor 16 may be configured to filter at least a second plurality of individual audio signals or may comprise

35 means for filtering the frequency bands (e.g. a digital filter bank).

The processor 16 corrects the beamforming within the problematic frequency rang using direct sound suppression enabling to cancel or to reduce sound towards a listening direction. The direct sound suppression may be achieved by a technique called beamforming or by a technique called dipoling. Both techniques enabling to improve the reproduction quality within the second (problematic) frequency band will be discussed separately, below. The two techniques have in common, that the sound within the second portion of the frequency range is canceled (or at least reduced in level) towards a listening direction. The listening direction is defined as being directed to a listening point or listening position, wherein listening point means an area defined by the one or more listeners. Note that direct sound suppression towards the listening direction means generating a radiation pattern having local sound reduction or local minimum (e.g. zero) in direction of the listening position.

According to a first technique, the problematic frequency range is not reproduced using the first beamforming reproduction but reproduced based on a so-called dipoling technique on the basis of the second plurality of individual audio signals (via same array 20 is controlled). Dipoling means that the sound signal to be reproduced is generated using at least two transducers which are separated from each other, wherein the transducers are driven by phase-shifted signals, e.g., phase-shifted by  $180^\circ$ . In other words, this means that it is possible to reproduce low frequencies over the array using such a "differential" concept, while a highly directive delay and sum beam at low frequencies is not possible with this array (having a typical size of a soundbar). The usage of the differential concept enables that sound can be reproduced as a figure-of-eight or cardioid by giving signals with different polarity and optional delays to the different loudspeakers 20a and 20d of the array 20.

Note that a sound signal reproduced in a differential manner, e.g. with a figure-of-eight directivity pattern (dipole), is typically more spacious when compared to sound signals reproduced conventionally. Therefore, very little sound reaches the listeners in front of the soundbar as most sound is emitted towards the left and the right. Thus, the listener will perceive mostly only room reflected sound and he will perceive the sound as very spacious – and not as directly coming from the soundbar. Moreover, this approach has benefits with regard to the effectiveness. The delay and sum projection beams at higher frequencies are more effective when lower frequencies are reproduced as spaciouly (e.g., as dipoles) than when low frequencies are reproduced conventionally. This is

because low frequencies will not pull the sound image of the surround channels towards the front.

5 With respect to the choice of the used transducers of the array 20, this means that – according to embodiments - preferably the dipoling is performed by the transducers which are arranged furthest away from each other, i.e., the outer transducers 20a and 20d.

10 According to a second technique the second plurality of individual audio signals are used to perform a so-called sound cancelation. Sound cancelation means that another beamforming reproduction is generated enabling to manipulate the first beamforming just within the problematic frequencies. Thus, the frequency band performed using the second beamforming reproduction has an overlap to the first frequency band within the problematic frequency ranges.

15 For example, as discussed above, a common problem with low frequencies is that no beam with high directivity can be formed. This leads to a situation that most of the sound within these low frequencies unintendedly reaches the listener from the front, and only a portion reaches the listener in the directed manner, e.g., reflected by the walls. In order to compensate this mismatch it is an option to direct another beam within these low  
20 frequencies towards the listener or listening area such that sound cancellation effects occur. Due to the sound cancellation the sound level or, to be more specific, the faulty reproduced sound level, e.g., in front of the soundbar, is reduced or, in general, corrected.

The detailed background in connection with the two applied techniques will be discussed  
25 below. The discussion is made starting from a problem analysis.

Fig. 2a shows the low frequency behavior of the soundbar 20. For low frequencies (for wave lengths at the size or larger than the physical dimensions of the loudspeaker array 20) the radiation pattern approaches the circle, with sound energy disseminated evenly in  
30 all directions. No spatial surround sound information can be extracted by the listener as a considerable amount of signal energy reaches the listener's position directly.

The aim of using beamforming for a soundbar 20 is to move signal energy away from the listener's position, such that the main portion of the signal energy no longer impacts  
35 directly (since this would be perceived as coming from the front). With a directed beam (cf. beam 21), the main part of the signal energy reaches the listener's position indirectly,

e.g., over the walls, and is therefore perceived as coming from a direction in which the beam is steered to or from a direction that does not coincide with the position of the array.

5 In order to accomplish that the techniques include the reflective surfaces present in the listening room. This is illustrated by Fig. 2b.

Fig. 2b also illustrates the combination of a low frequency dipole 23a and 23b as well as a high frequency beam 21 both emitted by the sound bar 20. The high frequency content is beamed and directed via a reflected surface 25 towards the listener 27, thus creating spatial perception. The figure-of-eight-pattern of the low frequency dipole 23a/23b shows how the null of the dipole is directed towards the listener 27, directing the main part of the signal energy towards the sides, thus also creating spatial perception.

15 With respect to the soundbar 20 it should be noted that the beamforming or, in general, the sound reproduction may be based on the theory of differential sound reproduction. Such differential sound reproduction concepts use reproduction concepts of first (preferably) or higher order. Note that for sound reproduction having a first order an array having two transducers suffice, wherein for sound reproduction having a second or higher order an array having more than two transducers is typically needed. The usage of sound reproduction of a higher order is predestined for the embodiments according to which a filtering of the individual audio signals is performed.

Fig. 3a shows a schematic representation of how, in a setup illustrated by Fig. 2b, audio content is distributed with regard to the respective frequency bands to the dipole 23a/23b and to the beam. As can be seen, the frequency portion reproduced by the dipole 23a/23b comprises low frequencies, wherein the beam 21 comprises high frequencies. The two respective frequency ranges may have an overlap. In order to separate these two frequency bands, the audio signals for reproducing the dipole are low-passed filtered, wherein the audio signals for reproducing the beam are high-pass filtered.

30

Fig. 3b illustrates an example implementation of a loudspeaker array 20 which can be used as soundbar for the above discussed reproduction comprising the two frequency bands. Here, the array comprises ten loudspeakers 20a to 20j which are arranged in line, wherein a spacing between the singular loudspeakers 20a to 20j may be of equal distance. It should be noted that the transducers 20a to 20j may be of the same type or of different types.

35

The sound signals enabling the above discussed sound reproduction are calculated as follows:

5 LF Dipole (cf. transducers 20a and 20j)

$$x_1(t) = L P F \{s(t)\}$$

$$x_{10}(t) = - L P F \{s(t)\}$$

10 HF Beam (with  $i = 1 \dots 10$ , all transducers of the array 20) (1)

HF Beam (with  $i = 1 \dots 10$ , all transducers of the array 20)

$$x_i(t) = H P F \{s(t + i \cdot \gamma - 10 T \cdot \gamma)\}$$

(2)

15

The equation (1) refers to the outermost transducers 20a and 20j in the array 20 and have the purpose to create the low frequency dipole as illustrated by Fig. 2b (cf. reference numbers 23a/23b). From the same loudspeaker array 20 using all ten drivers 20a to 20j, the equation 2 shows how the high frequency beam is created (cf. Fig. 2b, reference number 21).

20

Depending on certain factors (e.g., driver spacing in the physical array 20) it may happen that the use of beamforming is not suitable for the whole high frequency region. In this case, a dipole may also be used in certain high frequencies as illustrated by Figs. 4a and 4b.

25

Fig. 4a shows the array 20, wherein respective transducers 20a to 20j are grouped to the four groups 71, 72, 73 and 74. The transducers belonging to the four different groups 71, 72, 73 and 74 are used for the reproduction of different frequency bands. The mapping between the groups 71 to 74 and the respective frequency band is illustrated by Fig. 4b showing a diagram in which different portions are assigned to the respective groups 71 to 74. Two dipoles are formed by the groups 71 and 72, wherein the group 71 comprises the loudspeakers 20a and 20j and the group 72 comprises the loudspeakers 20c and 20h. These two dipoles 71 and 72 are used for the reproduction of low frequency bands.

30

Another dipole 74 is created within a high frequency band. This group of transducers 74 comprises the innermost pair of transducers, i.e., 20e and 20f. Between the low frequency band reproduced by using the dipole 71 and 72 and the high frequency band (cf. dipole 74) a fourth frequency band (cf. group 73) is arranged for the middle to high frequencies.

35

This frequency band is reproduced using beam forming. Therefore, the group 73 comprises all ten transducers 20a to 20j of the array.

5 Figs. 4c and 4d illustrate a refinement of the embodiment of Figs. 4a and 4b. The same array 20 is used. The outermost transducers 20a and 20j are used to create dipole 81, wherein the group 82 comprising the whole array 20 is used for forming the beam 82. Analogously to the embodiment of Fig. 4a and 4b the beam 82 comprises medium and high frequencies, wherein the dipole 81 comprises low frequencies as illustrated by the frequency diagram of Fig. 4d. The outermost four transducers, i.e., 20a, 20b, 20e and 20j  
10 are used to create two pairs of dipoles, here designated 83l and 83r. The two dipoles 83l and 83r (comprising the transducers 20a, 20b, 20e and 20j). These two dipoles 83l and 83r operate in the same frequency band comprising high frequencies. The dipole 83l is oriented to the left, wherein the dipole 83r is oriented to the right. This enables, for example, the reproduction of stereophonic audio.

15

Another preferred embodiment is illustrated by Figs. 5a and 5b, wherein the Fig. 5a shows the sound system 102 comprising the soundbar 20 and two additional separately enclosed loudspeakers 29a and 29b.

20 Fig. 5b illustrates the corresponding frequency diagram illustrating the signal portions of the entire frequency range assigned to the group of transducers of the sound system 102. Such a system 102 of Fig. 5a may preferably be used in combination with a television set. While the middle array 20, which can be used for beamforming, is always centered with respect to the screen (not shown). The detached side enclosures 29a and 29b can be  
25 positioned in the corners of the screen. Such, the maximum meaningful extent (the TV) is used in its entirety. The described concept is flexible enough to make best possible use of the actual spacing. Such, the driver arrangement of the sound system 102 is flexible with regard to different screen sizes while the underlying processing is basically always the same. Information about this absolute position can, for example, be gained from setup  
30 information that is transmitted from the TV, e.g., via HDMI.EDID, from user input or is known if the loudspeakers are integrated into the TV set.

As illustrated by Fig. 5b, the entire frequency range may be divided into four portions marked by the reference numerals 89a, 87a, 89b and 87b. The two portions 89a and 89b  
35 comprising low frequencies and medium frequencies are reproduced using dipoling with the separate transducers 29a and 29b as marked by the group 89a/89b. The second

portions 87a and 87b comprise a frequency range 87a arranged between the two frequency ranges 89a and 89b and a frequency range 87b comprising just high frequencies. These two frequency bands 87a and 87b are reproduced using beamforming, wherein all transducers of the array 20 as well as the transducers 29a and 29b operate.

Figs. 5c and 5d illustrate another refinement of the aforementioned embodiment. Fig. 5c illustrates the soundbar setup 104, wherein Fig. 5d illustrates the corresponding frequency diagram.

The sound setup 104 comprises two separate enclosures 29a' and 29b' and the array 20. The separate enclosures 29a and 29b differ from the enclosures 29a and 29b in such a way that same comprise two transducers in order to enable dipoling having a first order. Alternatively, the two separate loudspeaker elements 29a' and 29b' may be configured to perform dipoling having a second or higher order, wherein the sound reproduction / dipoling having a second or higher order typically uses three or more transducers. I.e., according to further embodiments, the soundbar setup 104 may comprise two separate enclosures 29a' and 29b', each comprising at least three transducers.

An exemplary grouping of the sound system 104 will be discussed below. For example, the two separate enclosures 29a' and 29b' may be grouped to the group 91 performing dipoling in a low frequency band, wherein each enclosure 29a' and 29b' forms their own dipole (cf. 93l and 93r). The array 20 is grouped to the group 92 which is reproduced by performing beamforming within the frequency portion 92 arranged between the frequency portions 91 and 93l/93r. An advantage is that the dipole processing can be used to enhance the playback performance. To achieve this (independently of the screen size) at least a pair of closely spaced loudspeakers, namely the two closely spaced drivers 29a' and 29b' are always positioned in each corner. Such, for frequencies that are too high to be beamformed, the sided dipoles can reproduce the high frequencies and steer a null towards the listener in order to generate a local sound minimum. Even though there might still be aliasing artifacts, the general direction of the high frequency content corresponds to the direction of the corresponding beam 92 (i.e., beam towards the left, left dipole for higher frequencies; same for right).

The described method cannot only be used for horizontal playback but also to reproduce vertically spatially spread sounds. For this, the loudspeaker array would have to be arranged vertically as illustrated by Fig. 7.

5 Fig. 7 illustrates further aspects according to which edge loudspeakers 29a'' to 29d'' as corner-enclosures are combined with vertically and horizontally placed arrays 20a' to 20d'. In addition to the described processing, the loudspeakers 29a'' to 29d'' at the edges of the television 40 can advantageously be used as corner loudspeakers for a panning system. As can be seen, the corner loudspeakers 29a'' to 29d'' are formed as single arrays 29a''  
10 to 29d'' each comprising at least three transducers being arranged on a flexed line, e.g. having an angle of 90°. Such corner loudspeakers 29a'' to 29d'' form a two-dimensional array enabling to perform vertical and horizontal beamforming or dipoling (wherein just three transducers are needed). Furthermore, the flexed arrangement enables optimal positioning the corner loudspeakers 29a'' to 29d'' at the corners of the display 40. The  
15 corner loudspeakers 29a'' to 29d'' may be described in other words as speaker having at least three transducers, wherein the three transducers are arranged as corner element such that two transducers of the three transducers are positioned vertically and two transducers of the three transducers are positioned horizontally. In general, the system of Fig. 7 comprising at least four loudspeakers in the corners of a display 40 serves the  
20 purpose to render sound on screen, at the same position as an accompanying picture.

It should be noted that one or more of the abovementioned corner loudspeakers 29a'' to 29d'' (stand-alone) form, according to embodiments, a sound system which can be used  
25 in combination with the above calculation unit to perform vertical and horizontal beamforming or dipoling.

Within above embodiments, although the arrays are discussed in context of arrays having similar transducers, it should be noted that also arrays having transducers of a different type, e.g., of a different size may be used as illustrated by Figs. 6a and 6b.

30 Fig. 6a shows an array 20' comprising nine transducers, wherein the two outermost transducers of a first side and the two outermost transducers of a second side are smaller when compared to the transducers in the middle. Such an array 20' may be used as a variation of the system 104 in which a number of transducers of larger size are used to  
35 reproduce audio via beamforming, wherein the array extends with two pairs of transducers

of smaller size which create side dipoles for a higher frequency content. As illustrated by Fig. 6a, this setup may be implemented into one single element.

5 Fig. 6b shows a variation of the array 20', namely the array 20'' which uses an array of smaller size transducers flanked by a pair of larger size transducers.

The two arrays 20' and 20'' or variations thereof may be used as arrays for the above embodiments. In above embodiments, it has preferably been explained that beamforming within a certain frequency range may be combined with dipoling in order to reproduce the  
10 "problematic" frequency bands more expedient.

The reproduction of the "problematic" frequency range, as discussed in context of Fig. 1, may be reproduced using beamforming in case the beamforming in the problematic frequency range is manipulated or corrected by use of another beamforming reproduction  
15 such that the entire result of the sound reproduction is comparable with the combination of beamforming and dipoling with regard to its reproduction quality. This second technique comprising beamforming in combination with sound cancelation will be discussed in detail below.

20 For this technique a calculation unit 60 may be used, as illustrated by Fig. 8. Fig. 8 shows an exemplary block diagram of a calculation unit 60 for processing the sound cancelation. The calculation unit 60 comprises two processing paths 62 and 63 and an optional equalizer 65 at the input. In the processing paths 62 and 63 the different frequency bands are processed separately. Here, the process path 62 used for calculating the first plurality  
25 of signals N62 (for the first beamforming reproduction) process the entire frequency band of the input stream using the beamformer 62b. In contrast, the path 63 used for the sound cancelation processes just a limited portion of the entire frequency band. Therefore path 63 comprises the filter 63a, arranged between the optional EQ 65 and the second beamformer 63b of path 63. Furthermore, 63 comprises an inversion-filter 63c (  
30  $-H_1(z)/H_2(z)$ ) ) arranged at the input of the beamformer 63b performing an inversion of the input signals such that the audio signals plurality N63 output by the beamformer 63b enable the direct sound suppression within the limited portion of the entire frequency band. The beamformer 63b outputs the second plurality of signals N63. The first plurality of audio signals N62 and the second plurality of audio signals plurality N63 are added  
35 using the mixer 64 and output to the array. Typically the mixer 64 is integrated into the output means of the calculation unit 60.

The concept of sound cancelation will be discussed with respect to Figs. 9a to 9c. Fig. 9a shows a directivity in dB of a (first) beamformer. This first beamforming may be reproduced using 20 equal distant drivers in 5cm distance. A steering angle of 45° should be reproduced. As can be seen, this beamformer alone has an insufficient directivity at low frequencies, e.g., sound below 300 Hz or 400Hz. Consequently, a listener sitting in front of the soundbar at 0° will localize sound below 300 Hz or 400Hz at 0°, the direction of the soundbar. This insufficient directivity at the portion of the entire frequency range below 300 or 400Hz may be corrected by using sound cancelation due to which a sound cancellation in this frequency portion and in the defective angle range may be performed. Consequently, the sound that reaches the listeners directly from the loudspeaker array in this portion is reduced by means of sound cancellation as illustrated by Fig. 9b.

Fig. 9b shows a directivity in dB of the beamformer, wherein a second beam within the problematic frequency range has been applied in order to cancel the unwanted directed sound of the first beam. The application of sound cancelation may lead to a directivity pattern having a minimum at low frequencies within the range of 30 to -30°. This result, as illustrated by Fig. 9b, may be further improved by means of an equalizer in order to compensate the loss at low frequencies. Therefore, the processor discussed with respect to Fig. 1 may further comprise an equalizer configured to perform an equalization within the second portion. The result of the equalization is illustrated by Fig. 9c. As can be seen, the directivity pattern within the low frequencies has a sharp notch at 0°. It should be noted that principle of sound cancelation and dipoling may be combined.

According to further embodiments, the lowpass channel may be supported by using a subwoofer. For such an use case, the processor may be configured to forward directly a signal received via the input means to the output means with or without filtering the signal. Note that this direct forwarding is not limited to single channels or certain frequency bands.

Although in the above embodiments the sound system has been described as a system comprising at least a soundbar, it should be noted that the system may also be formed by another type of array, e.g. an array comprising two or three separated transducers.

Although in the above embodiments the invention has been discussed in context of an apparatus, it should be noted that a further embodiment refers to a method for calculating

a sound reproduction for a sound system. The method comprises the steps of receiving an audio stream to be reproduced using the array and having a frequency range; calculating a first plurality of individual audio signals for the transducers such that beamforming is performed; calculating a second plurality of individual audio signals for the transducers of the sound system such that sound cancelation and/or dipoling is performed and filtering the first plurality of individual audio signals using a first bandpass characteristic comprising a first portion of the frequency range of the audio stream; filtering the second plurality of individual audio signals using a second passband characteristic comprising a second portion of the frequency range of the audio stream, wherein the second portion differs from the first portion; and outputting the individual audio signals of the first and second plurality in order to control the sound system.

Although some aspects have been described in the context of an apparatus, it is clear that these aspects also represent a description of the corresponding method, where a block or device corresponds to a method step or a feature of a method step. Analogously, aspects described in the context of a method step also represent a description of a corresponding block or item or feature of a corresponding apparatus. Some or all of the method steps may be executed by (or using) a hardware apparatus, like for example, a microprocessor, a programmable computer or an electronic circuit. In some embodiments, some one or more of the most important method steps may be executed by such an apparatus.

The inventive encoded audio signal can be stored on a digital storage medium or can be transmitted on a transmission medium such as a wireless transmission medium or a wired transmission medium such as the Internet.

Depending on certain implementation requirements, embodiments of the invention can be implemented in hardware or in software. The implementation can be performed using a digital storage medium, for example a floppy disk, a DVD, a Blu-Ray, a CD, a ROM, a PROM, an EPROM, an EEPROM or a FLASH memory, having electronically readable control signals stored thereon, which cooperate (or are capable of cooperating) with a programmable computer system such that the respective method is performed. Therefore, the digital storage medium may be computer readable.

Some embodiments according to the invention comprise a data carrier having electronically readable control signals, which are capable of cooperating with a

programmable computer system, such that one of the methods described herein is performed.

5 Generally, embodiments of the present invention can be implemented as a computer program product with a program code, the program code being operative for performing one of the methods when the computer program product runs on a computer. The program code may for example be stored on a machine readable carrier.

10 Other embodiments comprise the computer program for performing one of the methods described herein, stored on a machine readable carrier.

In other words, an embodiment of the inventive method is, therefore, a computer program having a program code for performing one of the methods described herein, when the computer program runs on a computer.

15 A further embodiment of the inventive methods is, therefore, a data carrier (or a digital storage medium, or a computer-readable medium) comprising, recorded thereon, the computer program for performing one of the methods described herein. The data carrier, the digital storage medium or the recorded medium are typically tangible and/or non-  
20 transitional.

A further embodiment of the inventive method is, therefore, a data stream or a sequence of signals representing the computer program for performing one of the methods described herein. The data stream or the sequence of signals may for example be  
25 configured to be transferred via a data communication connection, for example via the Internet.

A further embodiment comprises a processing means, for example a computer, or a programmable logic device, configured to or adapted to perform one of the methods  
30 described herein.

A further embodiment comprises a computer having installed thereon the computer program for performing one of the methods described herein.

35 A further embodiment according to the invention comprises an apparatus or a system configured to transfer (for example, electronically or optically) a computer program for

performing one of the methods described herein to a receiver. The receiver may, for example, be a computer, a mobile device, a memory device or the like. The apparatus or system may, for example, comprise a file server for transferring the computer program to the receiver .

5

In some embodiments, a programmable logic device (for example a field programmable gate array) may be used to perform some or all of the functionalities of the methods described herein. In some embodiments, a field programmable gate array may cooperate with a microprocessor in order to perform one of the methods described herein. Generally,  
10 the methods are preferably performed by any hardware apparatus.

The above described embodiments are merely illustrative for the principles of the present invention. It is understood that modifications and variations of the arrangements and the details described herein will be apparent to others skilled in the art. It is the intent,  
15 therefore, to be limited only by the scope of the impending patent claims and not by the specific details presented by way of description and explanation of the embodiments herein.

Claims

1. A calculation unit for a sound system comprising an array having a plurality of  
5 transducers, the calculation unit comprising:
- input means for receiving an audio stream to be reproduced using the sound system  
and having a frequency range;
- 10 a processor; and
- output means for controlling the sound system,
- wherein the processor is configured to calculate a first plurality of individual audio  
15 signals for the transducers of the array such that beamforming is performed by the  
array, wherein the first plurality of individual audio signals comprises a frequency  
range corresponding to a first portion of the frequency range of the audio stream,
- wherein the processor is configured to calculate a second plurality of individual audio  
20 signals for the transducers of the sound system to perform, using the sound system,  
direct sound suppression such that sound is canceled towards a listening direction,
- wherein the processor is configured to filter the second plurality of individual audio  
signals using a second passband characteristic comprising a second portion of the  
25 frequency range of the audio stream, wherein the second portion differs from the first  
portion;
- wherein the beamforming performed via the first plurality of individual audio signals is  
performed by using at least three audio signals such that at least three transducers  
30 are controlled;

wherein the first plurality of audio signals and the second plurality of audio signals are added using the mixer to be output to the one array comprising the transducers of the sound system which are controlled by the first and the second plurality of individual audio signals.

5

2. The calculation unit according to claim 1, wherein the direct sound suppression is performed using sound cancelation or dipoling.
  3. The calculation unit according to claim 2, wherein the sound cancelation comprises a manipulation of the beamforming within the second portion of the frequency range of the audio stream.
- 10
4. The calculation unit according to claim 2 or claim 3, wherein the sound cancelation corrects the beamforming performed via the first plurality of individual audio signals within the second portion of the frequency range.
- 15
5. The calculation unit according to claim 1 or claim 2, wherein second portion is a subset of the first portion.
- 20
6. The calculation unit according to any one of claims 1 to 5, wherein the processor is configured to filter the first plurality of individual audio signals using a first passband characteristic comprising the first portion of the frequency range of the audio stream.
- 25
7. The calculation unit according to any one of claims 2 to 6, wherein the dipoling is performed by providing at least two individual audio signals of the second plurality of individual audio signals for two different transducers in a phase-shifted manner or by providing at least two groups of individual audio signals of the second plurality of individual audio signals for two groups of different transducers in a phase-shifted manner.
- 30
8. The calculation unit according to claim 7, wherein the two individual audio signals or the two groups of individual audio signals are phase-shifted by 180°.

9. The calculation unit according to any one of claims 1 to 8, wherein the second portion of the frequency range is lower than the first portion of the frequency range.
- 5 10. The calculation unit according to any one of claims 1 to 9, wherein the beamforming performed via the second plurality of individual audio signals is performed by using at least three audio signals such that at least three transducers are controlled.
- 10 11. The calculation unit according to any one of claims 1 to 10, wherein different transducers are controlled via the first plurality of individual audio signals and via the second plurality of individual audio signals.
- 15 12. The calculation unit according to any one of claims 1 to 11, wherein all transducers of the array are controlled via the first plurality of individual audio signals and wherein a subset of transducers of the sound system is controlled via the second plurality of individual audio signals.
- 20 13. The calculation unit according to any one of claims 1 to 12, wherein the processor is configured to calculate a third plurality of individual audio signals for the transducers of the sound system such that dipoling is performed by the sound system and wherein the processor is configured to filter the third plurality of individual audio signals using a third passband characteristic comprising a third portion of the frequency range of the audio stream, wherein the third portion differs from the first portion and the second portion.
- 25 14. The calculation unit according to any one of the claims 1 to 12, wherein the processor is configured to calculate a third plurality of individual audio signals for the transducers of the sound system comprising a stereophonic reproduction,
- 30 wherein the processor is configured to filter the third plurality of individual audio signals using a third passband characteristic comprising a third portion of the

frequency range of the audio stream, wherein the third portion of the frequency range differs from the first and second portion of the frequency range.

5 15. The calculation unit according to any one of claims 1 to 14, wherein transducers of the sound system which are arranged furthest of each other are controlled via the second plurality of individual audio signals or via the third plurality of individual audio signals.

10 16. The calculation unit according to any one of claims 1 to 15, wherein the processor calculates the first plurality of individual audio signals  $x_i$  based on the formula

$$x_i(t) = \text{HPF}\{s(t + \tau_i)\},$$

15 wherein HPF complies with the first passband characteristic and  $\tau_i$  with a steering delay of transducers of the array, and

wherein the processor calculates the second plurality of individual audio signals  $x_1$  and  $x_n$  based on the formula

20

$$x_1(t) = \text{LPF}\{s(t)\}$$

$$x_n(t) = -\text{LPF}\{s(t)\},$$

wherein LPF complies with the second passband characteristic.

25

17. The calculation unit according to any one of claims 1 to 16, wherein the processor is configured to forward directly a signal received via the input means to the output means.

18. A sound system comprising:
- 5 the processor according to any one of claims 1 to 17 and an array having the plurality of transducers.
19. The system according to claim 18, further comprising at least two additional separated loudspeaker elements.
- 10 20. The system according to claim 19, wherein each of the two separated loudspeaker elements comprises an array having at least three transducers being arranged on a flexed line.
- 15 21. A method for calculating a sound reproduction for a sound system comprising an array having a plurality of transducers, the method comprises the following steps:
- receiving an audio stream to be reproduced using the array and having a frequency range;
- 20 calculating a first plurality of individual audio signals for the transducers of the array such that beamforming is performed via the array, wherein the first plurality of individual audio signals comprises a frequency range corresponding to a first portion of the frequency range of the audio stream;
- 25 calculating a second plurality of individual audio signals for the transducers of the sound system to perform, using the sound system, direct sound suppression such that sound is canceled towards a listening direction;
- 30 filtering the second plurality of individual audio signals using a second passband characteristic comprising a second portion of the frequency range of the audio stream, wherein the second portion differs from the first portion; and

outputting the individual audio signals of the first and second plurality in order to control the sound system;

5 adding the first plurality of audio signals and the second plurality of audio signals using the mixer to be output to the one array comprising the transducers of the sound system which are controlled by the first and the second plurality of individual audio signals.

10 22. A computer-readable medium having computer-readable code stored thereon to perform the method according to claim 21 when the computer-readable medium is executed by a processor of a computer.

15 23. A calculation unit for a sound system comprising an array having a plurality of transducers, the calculation unit comprising:

input means for receiving an audio stream to be reproduced using the sound system and having a frequency range;

20 a processor; and

output means for controlling the sound system,

25 wherein the processor is configured to calculate a first plurality of individual audio signals for the transducers of the array such that beamforming is performed by the array, wherein the first plurality of individual audio signals comprises a frequency range corresponding to a first portion of the frequency range of the audio stream,

30 wherein the processor is configured to calculate a second plurality of individual audio signals for the transducers of the sound system to perform, using the sound system, direct sound suppression such that sound is canceled towards a listening direction,

wherein the processor is configured to filter the second plurality of individual audio signals using a second passband characteristic comprising a second portion of the frequency range of the audio stream, wherein the second portion differs from the first portion;

5

wherein the direct sound suppression is performed using sound cancelation, wherein the sound cancelation corrects second plurality of individual audio signals within the second portion of the frequency range using beamforming performed via the first plurality of individual audio signals;

10

wherein the first plurality of audio signals and the second plurality of audio signals are added using the mixer to be output to the one array comprising the transducers of the sound system which are controlled by the first and the second plurality of individual audio signals.

15

24. A calculation unit for a sound system comprising an array having a plurality of transducers, the calculation unit comprising:

20

input means for receiving an audio stream to be reproduced using the sound system and having a frequency range;

a processor; and

25

output means for controlling the sound system,

30

wherein the processor is configured to calculate a first plurality of individual audio signals for the transducers of the array such that beamforming is performed by the array, wherein the first plurality of individual audio signals comprises a frequency range corresponding to a first portion of the frequency range of the audio stream,

wherein the processor is configured to calculate a second plurality of individual audio signals for the transducers of the sound system to perform, using the sound system, direct sound suppression such that sound is canceled towards a listening direction,

5 wherein the processor is configured to filter the second plurality of individual audio signals using a second passband characteristic comprising a second portion of the frequency range of the audio stream, wherein the second portion differs from the first portion;

10 wherein the beamforming performed via the first plurality of individual audio signals is performed by using at least three audio signals such that at least three transducers are controlled,

wherein second portion is a subset of the first portion;

15 wherein the first plurality of audio signals and the second plurality of audio signals are added using the mixer to be output to the one array comprising the transducers of the sound system which are controlled by the first and the second plurality of individual audio signals.

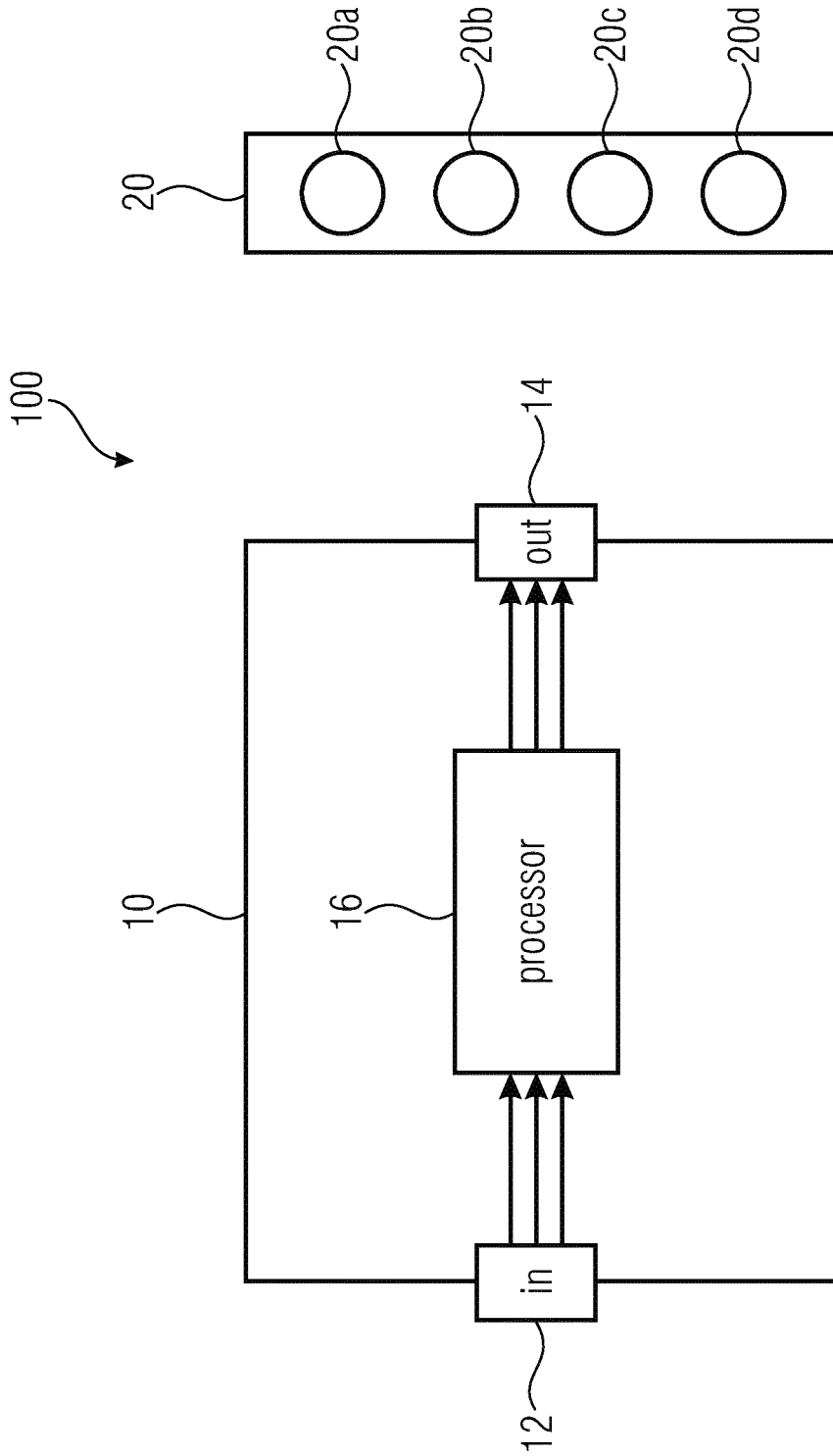

FIG 1

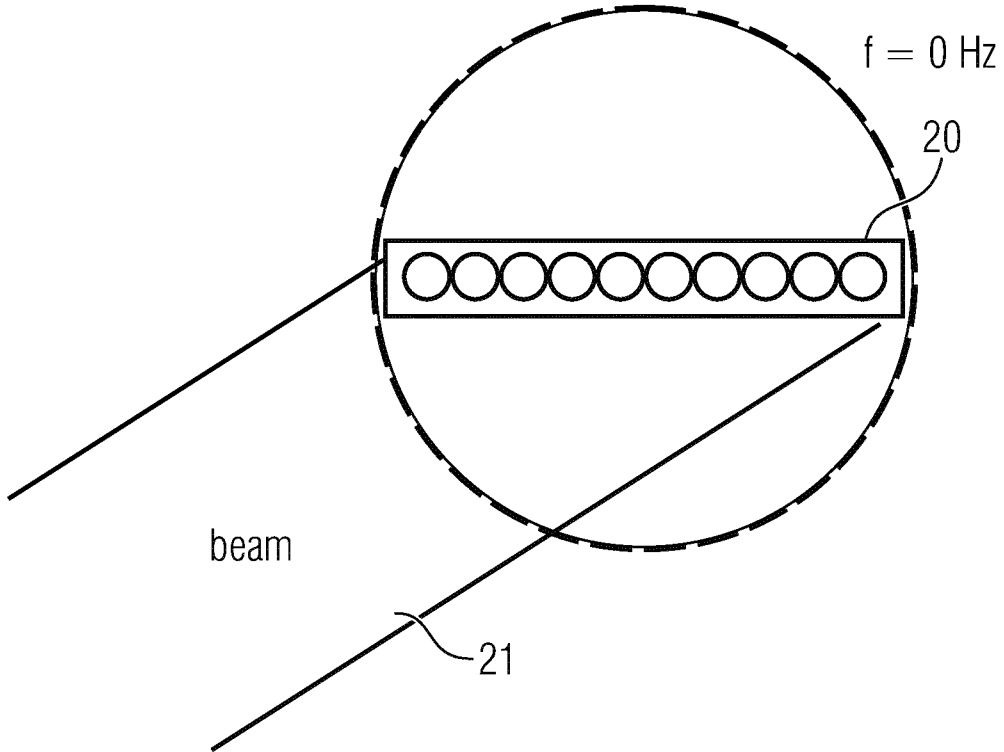

FIG 2A

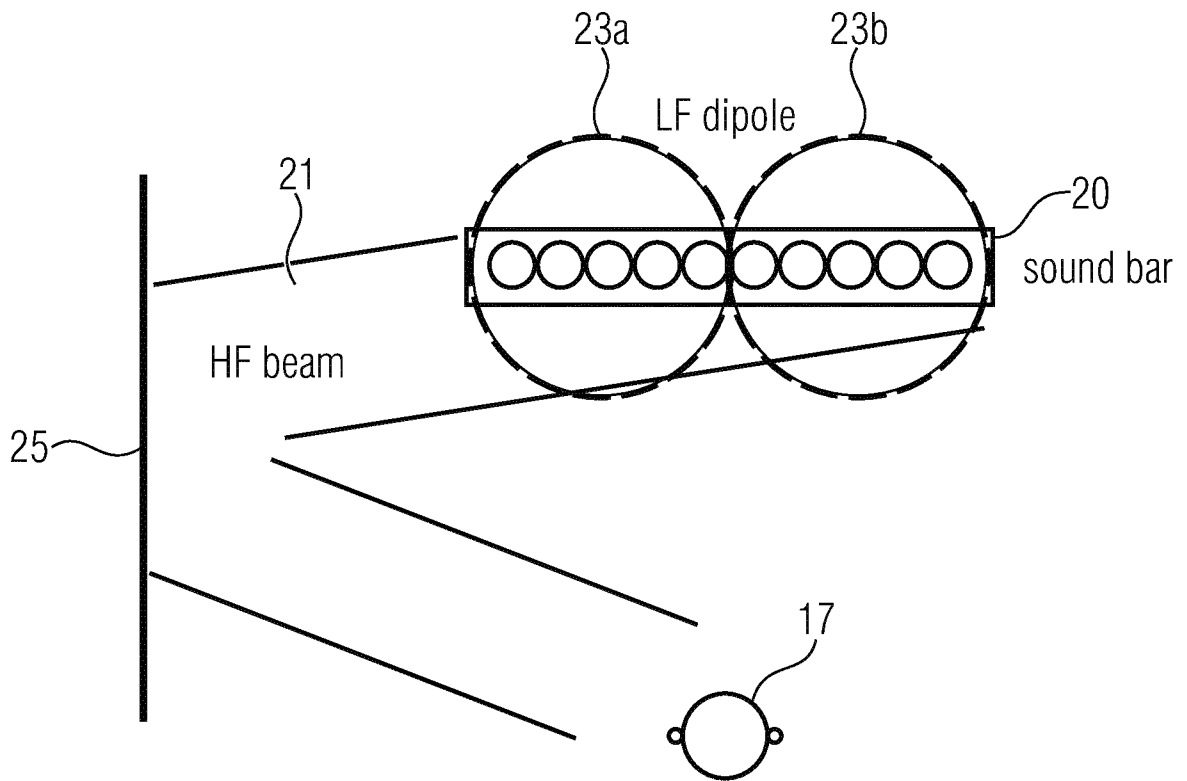

FIG 2B

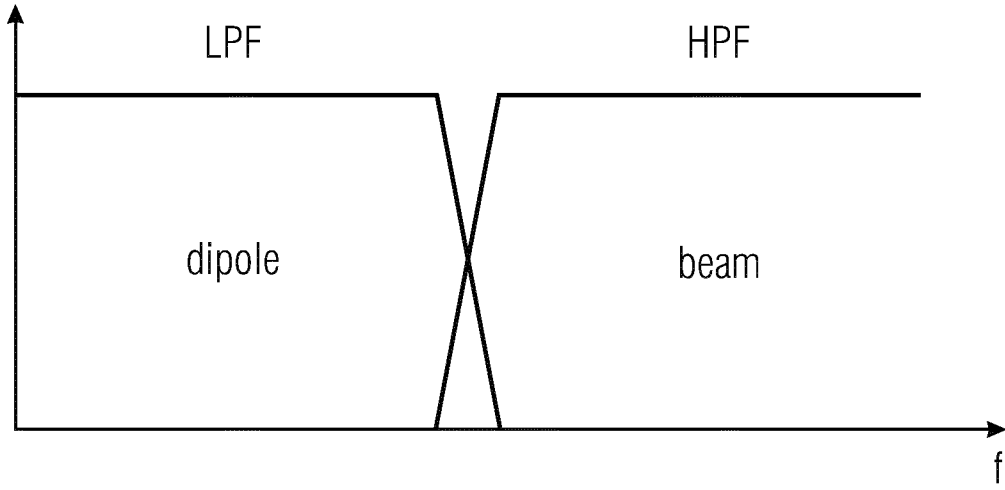

FIG 3A

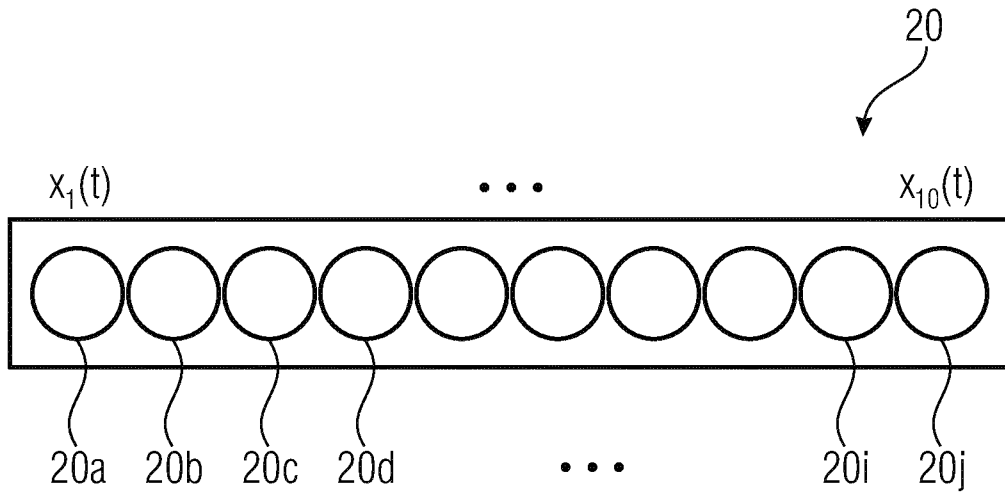

FIG 3B

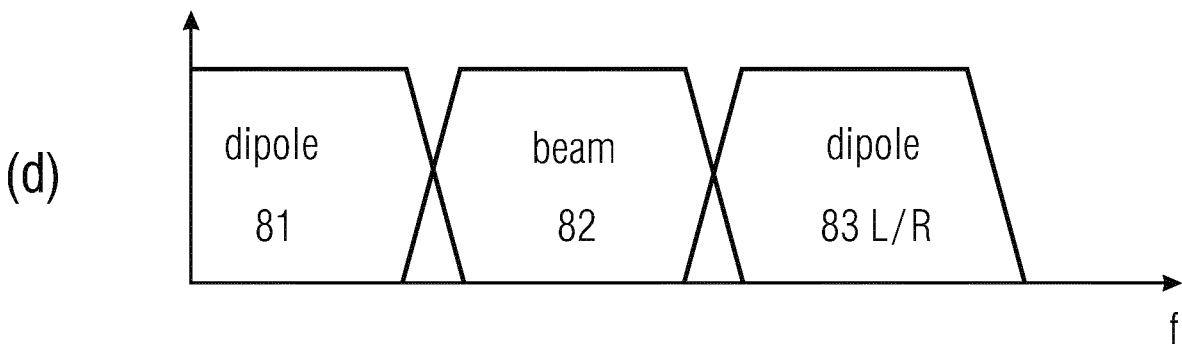
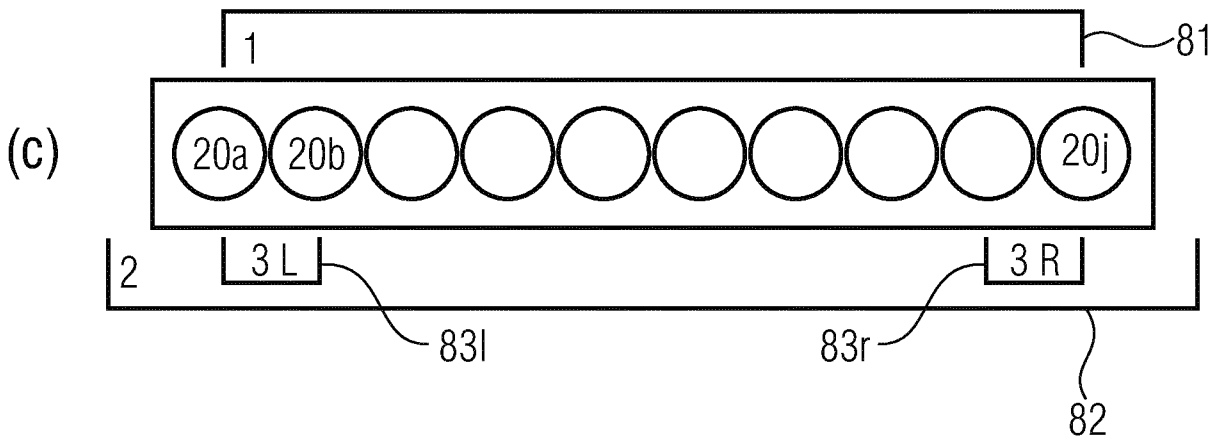
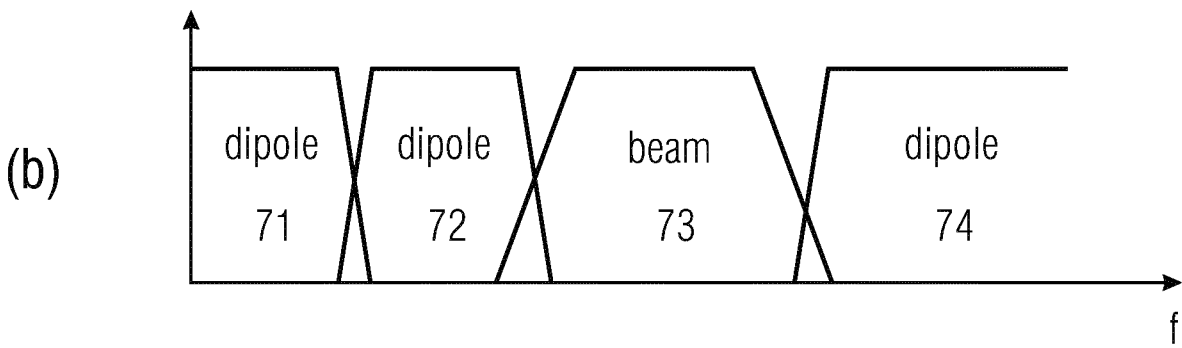
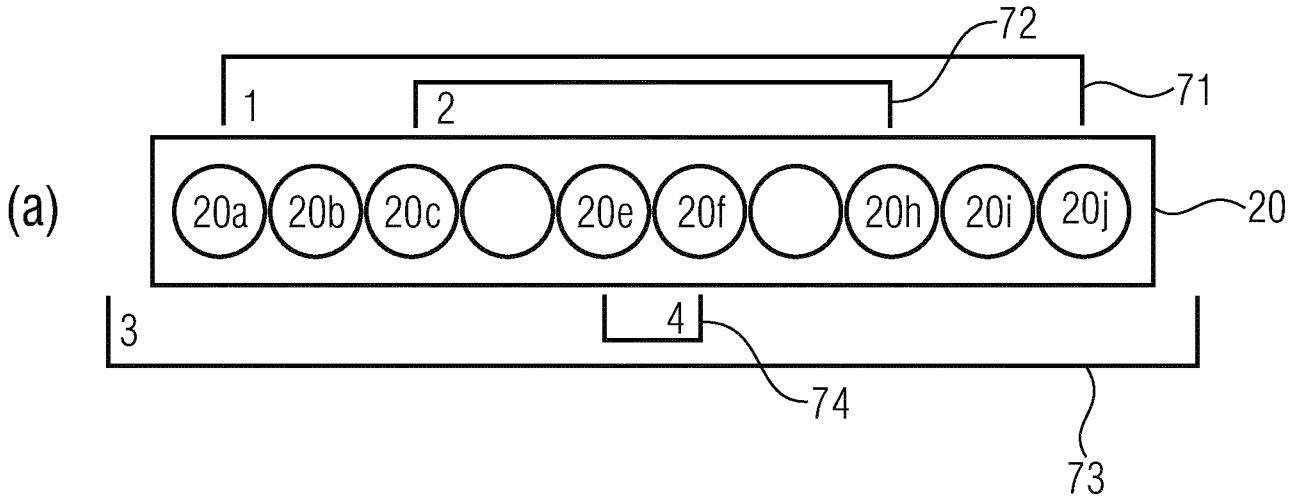

FIG 4

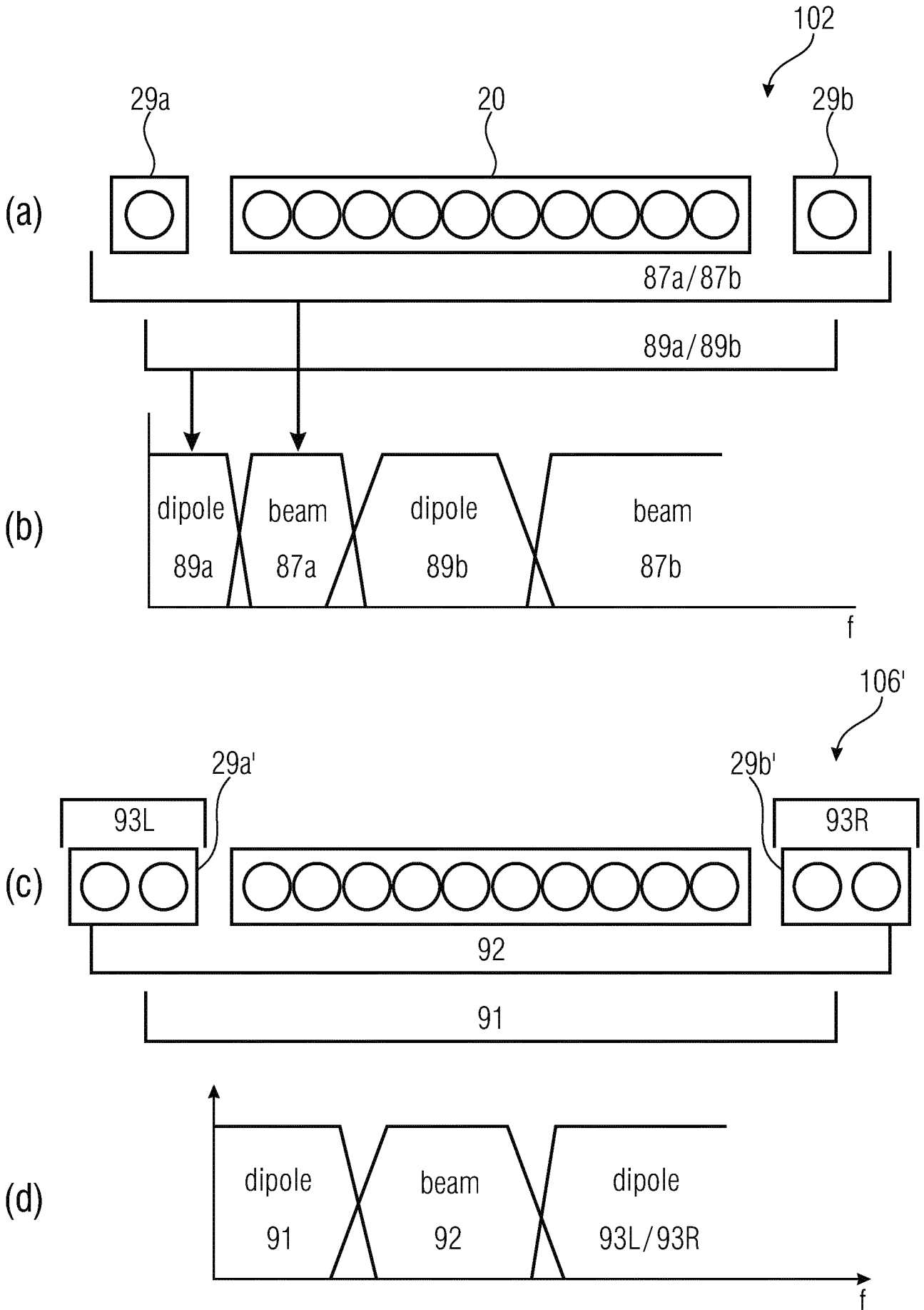

FIG 5

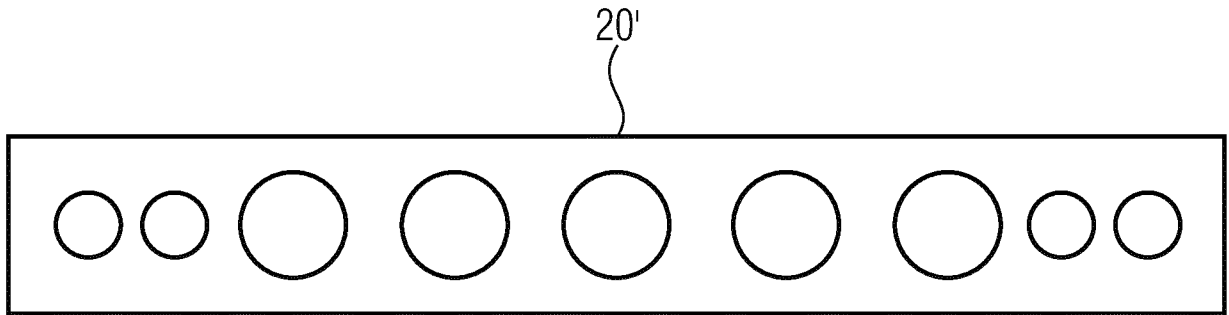

FIG 6A

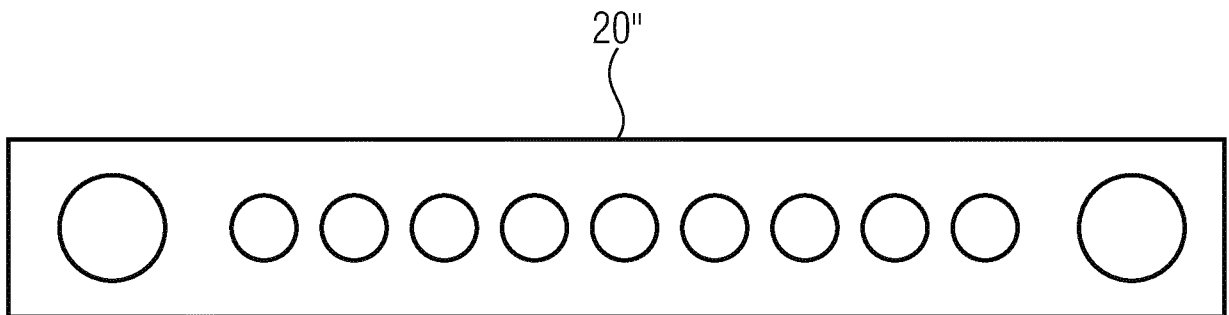

FIG 6B

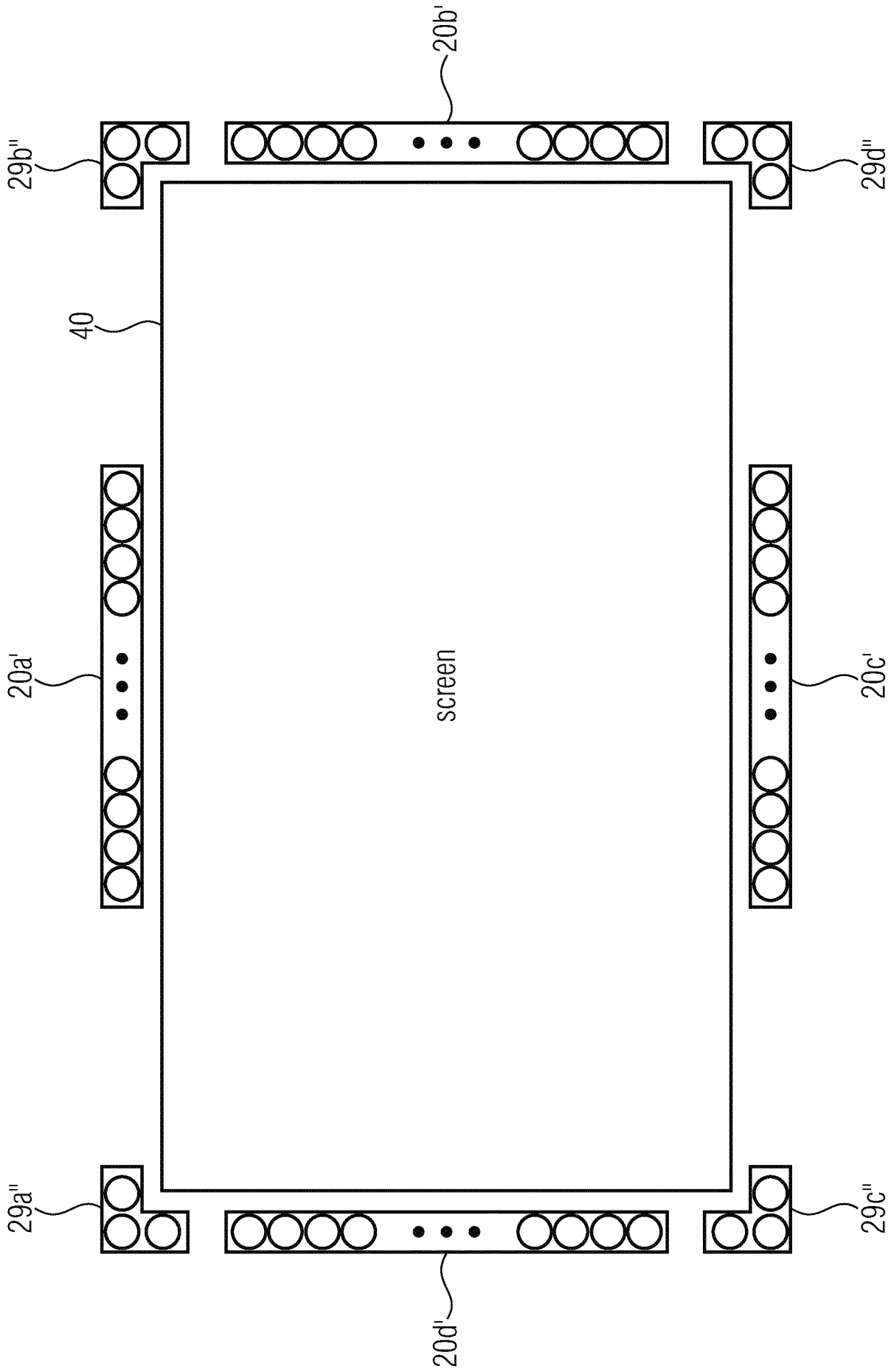

FIG 7

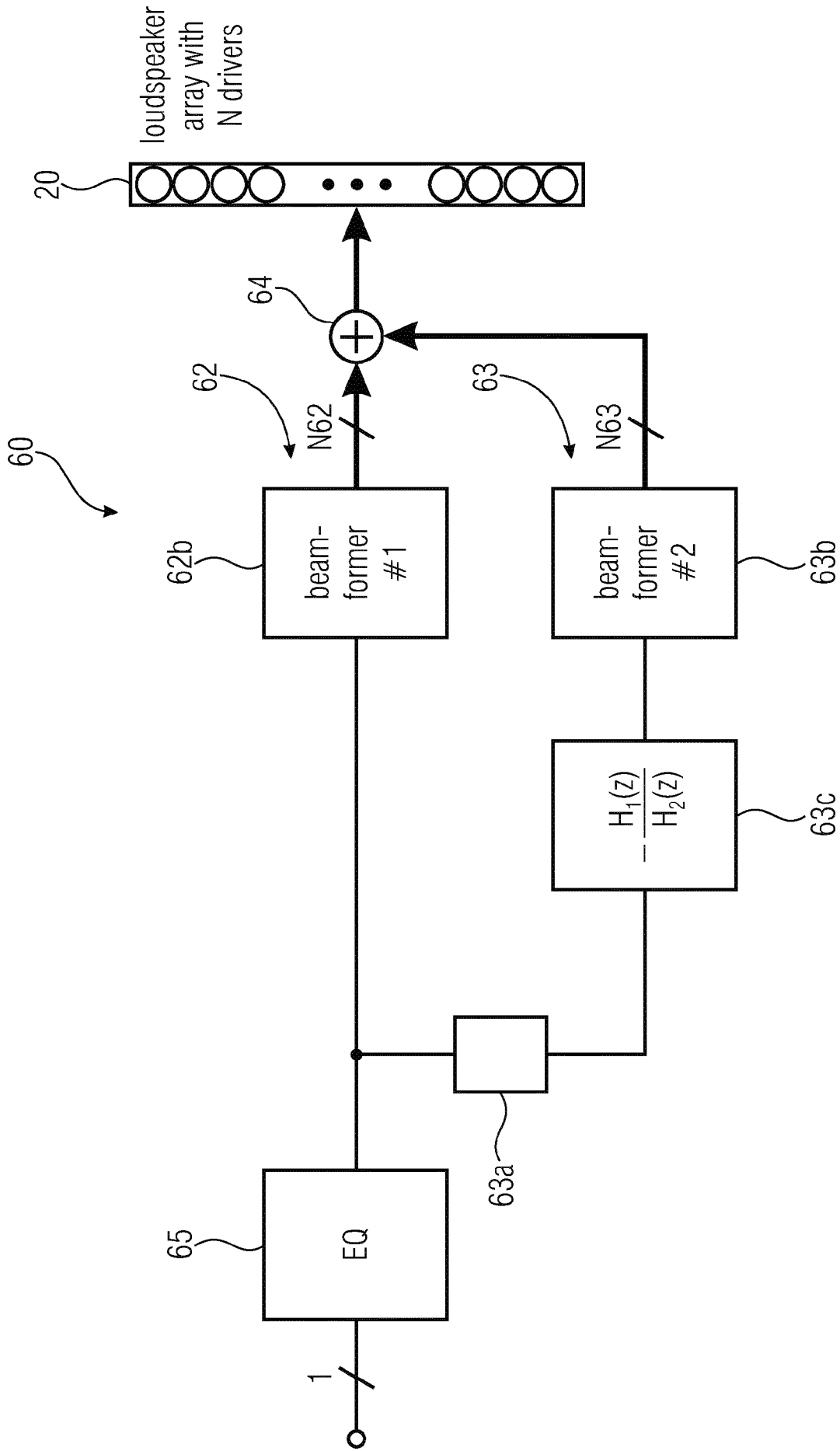

FIG 8

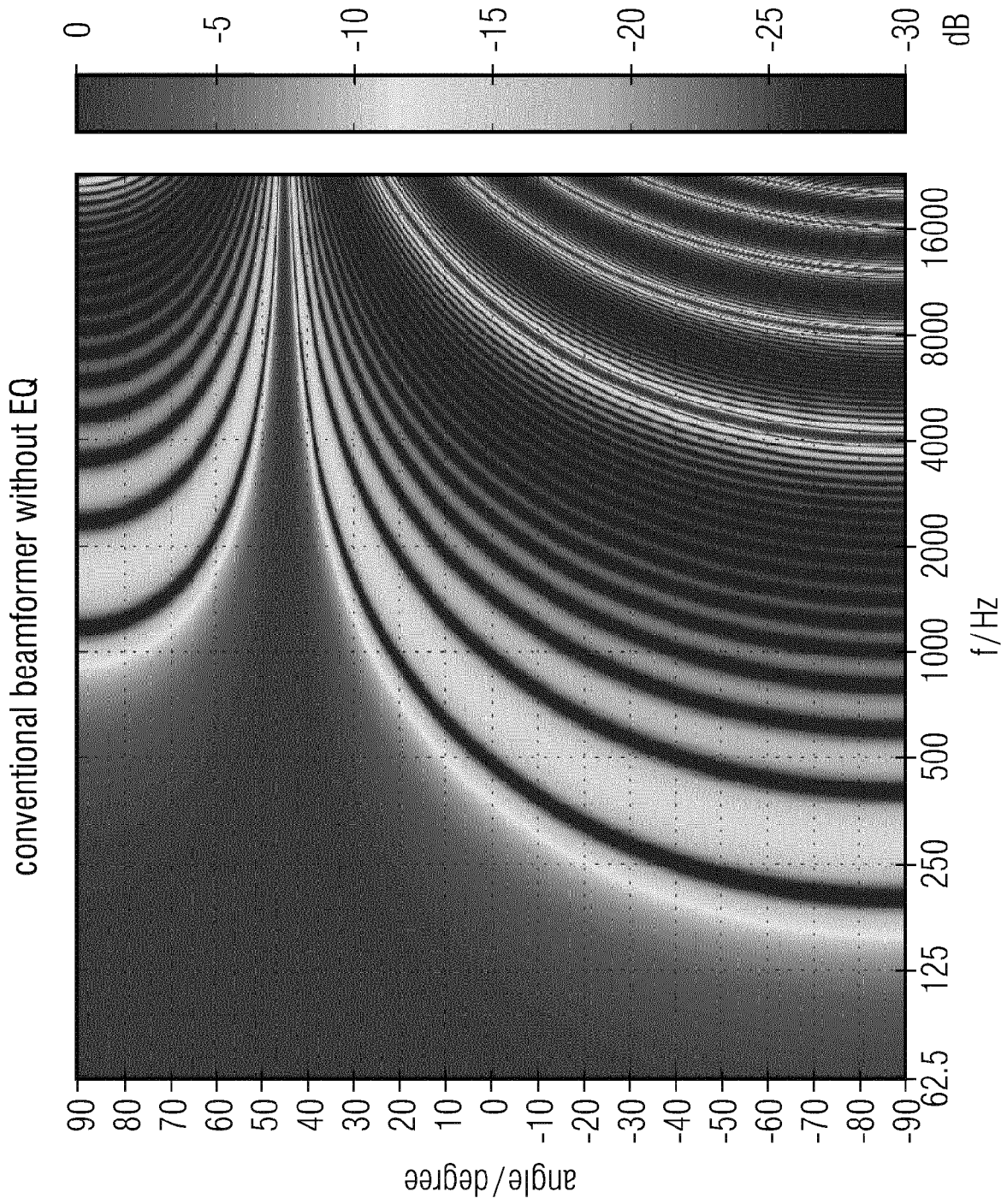

FIG 9A

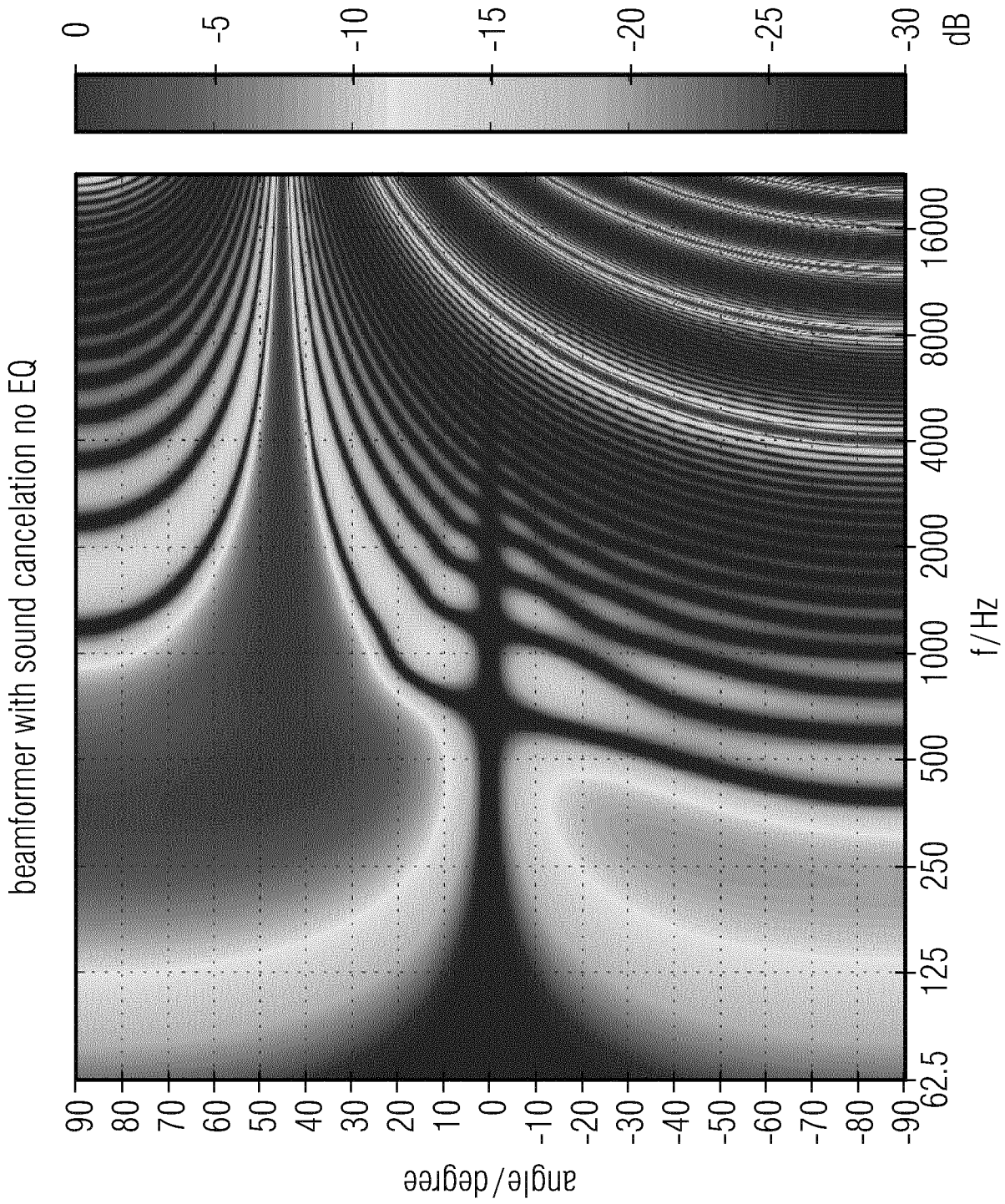

FIG 9B

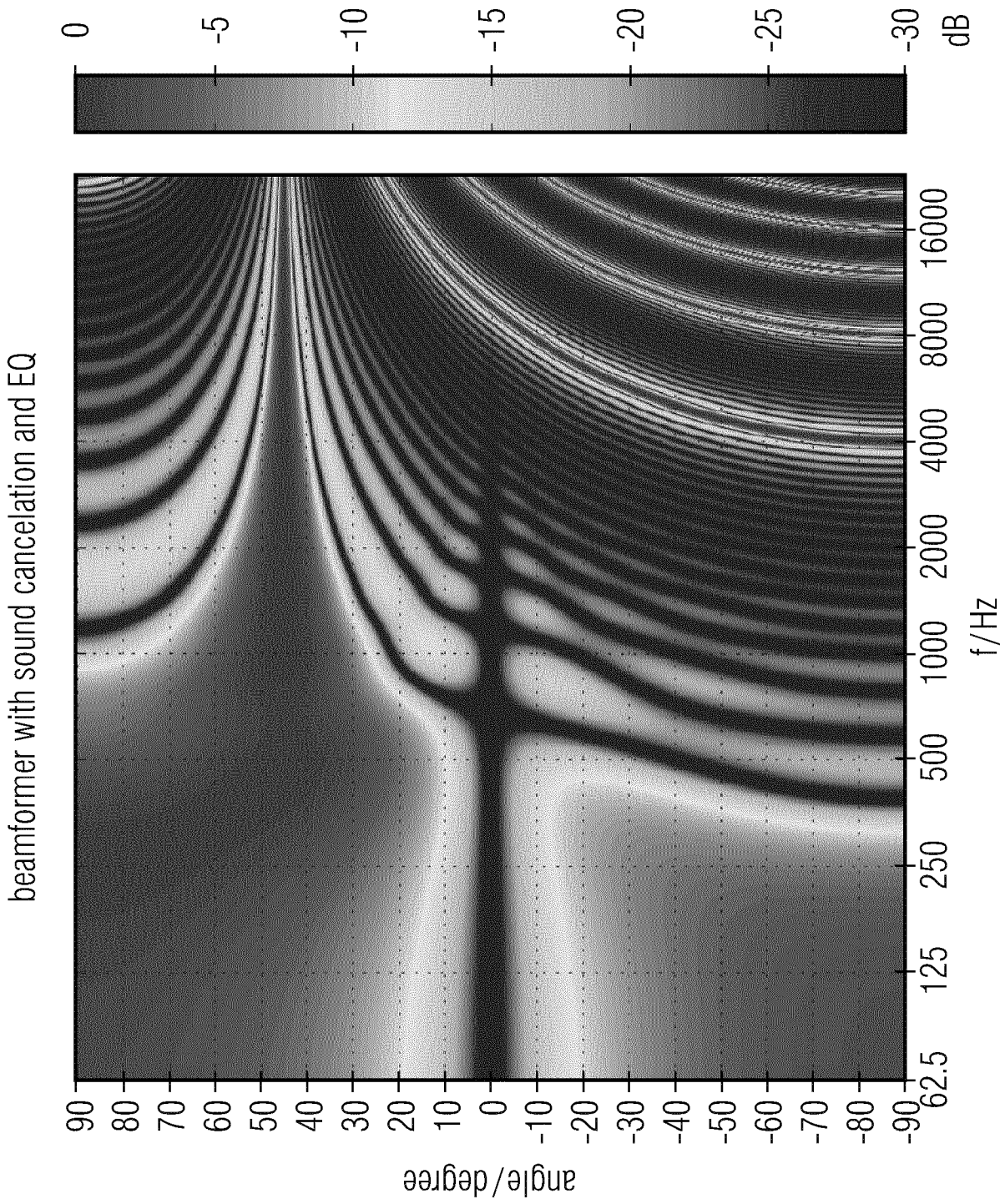

FIG 9C

