

(19)



(11)

EP 1 604 587 B1

(12)

EUROPEAN PATENT SPECIFICATION

(45) Date of publication and mention of the grant of the patent:
30.04.2008 Bulletin 2008/18

(51) Int Cl.:
A45F 5/02 (2006.01) F41C 33/04 (2006.01)

(21) Application number: **04466014.0**

(22) Date of filing: **11.06.2004**

(54) **Belt attachment**

Vorrichtung zur Befestigung an einem Gürtel

Dispositif d'attache à une ceinture

(84) Designated Contracting States:
AT BE BG CH CY CZ DE DK EE ES FI FR GB GR HU IE IT LI LU MC NL PL PT RO SE SI SK TR

(43) Date of publication of application:
14.12.2005 Bulletin 2005/50

(73) Proprietors:

- **Kostal, Bretislav**
10600 Praha 10 (CZ)
- **Kupa, Vladimir**
150 00 Praha 5 (CZ)

(72) Inventors:

- **Kostal, Bretislav**
10600 Praha 10 (CZ)
- **Kupa, Vladimir**
150 00 Praha 5 (CZ)

(74) Representative: **Rezac, Petr**
Jihozápadní-III 1145/4
141 00 Praha 4 (CZ)

(56) References cited:
DE-A- 19 902 682 **FR-A- 2 840 168**
US-A- 5 730 348 **US-A- 5 738 432**
US-A- 5 875 944

EP 1 604 587 B1

Note: Within nine months from the publication of the mention of the grant of the European patent, any person may give notice to the European Patent Office of opposition to the European patent granted. Notice of opposition shall be filed in a written reasoned statement. It shall not be deemed to have been filed until the opposition fee has been paid. (Art. 99(1) European Patent Convention).

Description

[0001] The invention relates to a belt attachment with fastening clips adjustable into an opened and closed position. The belt attachment is designed as a means for attaching various items such as a baton holder gun etc. to the belt of the item's user, for example a law enforcement personnel, fire brigades etc.

Description of the prior art

[0002] One of the possible embodiments of the belt attachment associated with a police baton holder is described in US patent 4 662 552. The attachment is a part of a holder of a baton to be attached to the belt. The holder carries a basic support, in which four slots symmetrically arranged are located. Two lengths of webbing provided by VELCRO fastener materials are treaded through the slots to firmly fix the support to the belt. Nevertheless, the VELCRO joint cannot prevent the attachment against an unauthorized release, for example when an officer is in a close contact with a suspect. To ensure a firm attachment to the belt the support shall have sufficient length, what on the other hand may restrict the persons bearing the belt from free movement in certain positions.

[0003] Similar type of a belt attachment is disclosed in US patent 5 893 630, where instead of two webbing a belt loop is used. The loop wraps downwardly around the officer's belt to allow snaps on the lower portions of the belt loop to be snapped. Like the VELCRO joint the snaps do not provide a firm and uneasy releasable connection. Moreover, the length of the loop engaging the belt cannot be adapted to the belt size.

[0004] A belt attachment according to US patent 6 059 157 constitutes an integral part of the back cover of a baton holder and includes a loop to be suspended from the belt. The end of the loop is secured to the holder by screws, which tighten down the loop against the belt. Like in the previous case the loop cannot be adapted to the belt size, specifically to its width and the mounting thereof on and dismantling from the belt requires the application of special instruments and screws that must be stored for further use. The belt attachment is designed for a specific item - a baton holder and can be hardly used in connection with another item.

[0005] A belt attachment according to the preamble of claim 1 is disclosed in US 5 730 348 A.

Summary of the invention

[0006] The principal object of the invention is to provide a belt attachment that may be adjusted with respect to the belt width and quickly and safely fixed to the belt to carry a variety of items that may be easily connected to the belt attachment.

[0007] A belt attachment according to the invention is described in claim 1.

[0008] In one specific embodiment the bush may include a bottom and side walls with grooves for receiving slides and an upper cross wall forming a lip of the upper clip. The insert may further consist of two elongated L-shaped profiles joined together by a central plate defining an upper and lower portion of the insert whereby the upper portion defines the space for the lower clip and the lower portion between the slides defines the space for the securing member.

[0009] Accordingly, the belt attachment thus includes two principal parts movable with respect to each other and which may be easily moved to a closed or opened position. The both positions of the belt attachment are secured by one securing member.

[0010] The securing member may consist of two resilient arms provided by catches at their free ends. The arms are linked together by a cross beam and the slides have two opposite situated recesses and the side walls of the bush two opposite situated upper apertures and two opposite situated lower apertures for receiving the catches.

[0011] To adapt the belt attachment to the belt size the L-profiles are in the upper portion of the insert provided by an internal tooth system and the base of the lower clip is on its opposite outer walls provided by a complementary external tooth system. The plate has an elongated cut-out situated along the central axis of the insert and the lower clip has an opening the axis of which intersects the axis of the cut-out.

[0012] To enable an easy operation of the belt attachment the insert is provided on its lower side by a holder extending above the upper surface of the plate and the cross beam of the securing member is provided by a grip extending above the lower surface of the arms and the outer side walls of the bush have recesses in the area of the upper apertures.

[0013] In order to ensure a safe checking of the closed position of the belt attachment the plate of the insert has on its upper side wall a projection and the cross wall of the bush has a hole for receiving the projection, when the belt attachment is in its closed position.

[0014] To enable the connection of a variety of items to the belt attachment the bottom of the bush has an opening and on the outer back surface of the bottom a concentric tooth system is provided around the axis of the opening.

[0015] Other principal features and advantages of the invention will become apparent to those skilled in the art upon review of the following drawings the detailed description and the appended claims.

Brief description of the drawings

[0016]

Fig. 1 - is a front perspective view of a bush as one part of the belt attachment;

Fig. 2 - is a front perspective view of an insert as

another part of the belt attachment;

Fig. 3 - is a front perspective view of a securing member;

Fig. 4 - is a side view of an assembled belt attachment in opened configuration;

Fig. 5 - is a side view of an assembled belt attachment in closed configuration;

Fig. 6 - is a sectional side view of an assembled belt attachment in an opened configuration;

Fig. 7 - is a side view of a belt attachment in connection with a baton holder.

Description of the preferred embodiment

[0017] A belt attachment of the invention consists of an upper clip 12 connected to a bush 1 and an lower clip 3 mounted on the insert 2 provided with slides 23 for insertion in the bush 1 and further of a securing member 4. The bush 1 (Fig. 1; Fig. 6) has a U-shaped profile with partially inclined side walls 10 and a bottom 11. At its upper end the bush is closed by a cross wall 19 forming a lip 121 of the upper clip 12, which is designed to be suspended from a belt (not shown in the drawings) carried by a person using the belt. The inner surfaces of each side wall 10 of the bush 1 are formed into a groove 13 of approximately oblong cross profile. In the bottom wall of each groove 13 elongated apertures 15 and 16 are disposed symmetrically of the bush 1 central longitudinal axis. At the orifice of each upper aperture 15 the surface of the outer side wall 10 is provided with an annular recess 14. In the upper portion of the bottom 11 a circular opening 18 and in the cross wall 19 an oblong shaped hole 17 is located.

[0018] The insert 2 (Fig. 2; Fig. 6) comprises two elongated parallel L-shaped profiles 22 joined together by a plate 21. The lower portions of the L-shaped profiles 22 represent slides 23 that fit in the grooves 13 of the bush 1 for longitudinal motion. The outer distance between the upper portions of the profiles 22 above the plate 21 is determined to enable their free movement between the side walls 10 of the bush 1. The inner surfaces of the upper portions of the profiles 22 include tooth system 25. In the upper section of the slides 23 two opposite situated recesses 26 for a securing member 4 are provided. The upper edge 27 of the plate 21 includes a projection 271 and the lower side of the plate 21 includes a holder 28 with a recess 29. Along the central axis of the plate 21 there is an elongated cut-out 20.

[0019] The lower clip 3 consists of a base 31 with a cross wall 37 and a lip 32. Either of the opposite lateral sides of the base 31 includes the tooth system that is sized to fit in the tooth system 25 at any place between the profiles 22 of the insert 2. The base 32 has an opening 36 and the lip 32 another coaxial opening 33 both situated in the manner that their common axis intersects the axis of the elongated cut-out 20 in the plate 21. The base 31 is connected to the plate 21 by a bolt joint 39.

[0020] The securing member 4 (Fig. 3; Fig. 6) includes

a cross beam 41 and two upwardly extending resilient arms 42 provided by outwardly projecting catches (46) with rounded edges at their free ends 46. The cross beam 41 includes a grip (44) extending above the lower surface of the arms (42).

[0021] In assembling the belt attachment, first the securing member is placed into the recess 29 of the insert 2 so that the catches 46 engage the recesses 26 in the slides 23 and the arms 22 seat against the back side of the insert 2 (Fig. 4; Fig. 6). Thereafter, the slides 23 are put in the grooves of the bush 1 to enable the upper edge 27 of the plate 21 to seat against the inner surface of the cross wall 19 of the upper clip 12 and at the same time the projection 271 engages the hole 17 so that the upper edge of the projection 271 extends over the outside surface of the cross wall 19 of the upper clip 12 (Fig. 5). In this configuration the catches 46 fit in the apertures 15 of the bush 1 to ensure the locking of the insert 2 in the bush 1. In the course of insertion of the insert 2 into the bush 1 the catches 46 are retained in the lower apertures 16, nevertheless due to the rounded ends of the catches 46 the insert 2 is not firmly locked in the bush 1 and the insert 2 may be further pushed upwardly to engage the cross wall 19 of the upper clip 12. Thereafter the bush 1 may be suspended by means of the upper clip 12 from the belt and the base 31 placed on the plate 21 of the insert 2 so that the tooth system 35 of the base 3 fit in the tooth system 25 of the insert 2 and the lower clip 3 together with the upper clip 12 hold firmly on the belt. Thus the belt attachment is adapted to a specific belt size. The base 32 is then fixed to the plate 21 by means of a bolt joint 36 through the cut-out 20. At this point the assembly of the belt attachment is finished.

[0022] The fastening of the belt attachment to the belt proceeds in such a manner that the bush 1 is first suspended by means of the upper clip 12 from the belt and by pushing the holder 28 upwardly the insert 2 is moved inside the bush 1. In this operation it is to care that the lip 32 of the lower clip 32 overlaps the belt. When the belt is gripped between the upper and lower clips the catches 46 fit in the apertures 15 of the bush 1 and the insert is immovably locked in the bush 1 and the belt attachment holds firmly on the belt. The safety of the closed position may be easily checked by viewing or touching the extending catches 46 in the recesses 14 or still more easily by monitoring the projection 271 that shall protrude from the hole 17. This projection is designed to enable easy monitoring of the closed position.

[0023] In releasing the belt attachment from the belt first the catches 46 of the resilient arms 42 are to be pushed inwardly by fingers and by pulling the holder 28 downwardly the insert 2 is shifted to the position, where the catches 46 fit in the lower apertures 16 of the bush 1 so that the belt attachment takes its opened position and it may be removed from the belt. The described design enables the belt attachment to be fastened to and released from the belt by one hand only.

[0024] Fig. 7 shows an embodiment, where the belt

attachment is connected to a baton holder 5 by means of a bolt joint 58 passing through the opening 18 in the bottom 11 of the bush 1. The bottom 11 of the bush 1 and the adjacent wall of the baton holder are separated by a washer 58. The bolt joint 58 enables the baton holder to turn on the bolt joint axis and so to elect the most convenient position of the baton holder with respect to the belt attachment and relative to the belt. The baton holder may be safely stabilized in the elected position by means of a radial tooth system provided on the washer faces and by a complementary tooth system on the back side of the bush 1 and the adjacent wall of the baton holder.

Industrial applicability

[0025] The belt attachment according to the invention may be used for connection of various equipment to the belt such as batons, defensive and offensive weapons etc. used for example by law enforcement forces, fire brigades or army. The belt attachment may also be used in performing other professional or leisure activities for example high rise buildings works, climbing etc..

Claims

1. A belt attachment with fastening clips adjustable to an opened and closed position comprising an upper clip (12) connected with a bush (1) and a lower clip (3) **characterized in that** the lower clip (3) includes a base (31) releasably mounted on an insert (2) so that the position of the lower clip (32) with respect to the insert (2) is adjustable along the longitudinal axis of the insert (2) and the bush (1), the insert including slides (23) mounted for longitudinal motion in the bush (1) along its longitudinal axis and a securing member (4) to secure the insert (2) in the bush (1) in one closed position and in at least one opened position of the attachment.
2. A belt attachment of claim 1 **characterized in that** the bush (1) includes a bottom (11) and side walls (10) with grooves (13) for receiving slides (23) and an upper cross wall (19) formed into a lip (121) of the upper clip (12).
3. A belt attachment of claim 1 **characterized in that** the insert (2) consists of two elongated L-shaped profiles joined together by a central plate (21) defining an upper and lower portion of the insert (2), whereby the upper portion defines the space for the lower clip (3) and the lower portion between the slides (23) defines the space for the securing member (4).
4. A belt attachment of any of claims 1 to 3 **characterized in that** the securing member (4) consists of two resilient arms (42) provided by catches (46) at their free ends, which arms are linked together by a cross beam (41) and the slides (23) have opposite situated recesses (26) and the side walls (10) of the bush (1) two opposite situated upper apertures (15) and two opposite situated lower apertures (16) for receiving the catches (46).
5. A belt attachment of claim 3 **characterized in that** the L-shaped profiles are in the upper portion of the insert (2) provided by an internal tooth system (25) and the base of the lower clip (3) is on its opposite outer walls provided by a complementary external tooth system (35).
6. A belt attachment of claims 3 or 5 **characterized in that** the plate (21) has an elongated cut-out (20) situated along the axis of the insert (2) and the lower clip (3) has an opening (33) the axis of which intersects the axis of the cut-out (20).
7. A belt attachment of any of claims 1, 2 and 6 **characterized in that** the insert (2) is provided on its lower side by a holder (28) extending above the upper surface of the plate (21).
8. A belt attachment of claim 4 **characterized in that** the cross beam (41) of the securing member (4) is provided by a grip (44) extending above the lower surface of the arms (42).
9. A belt attachment of any of claims 1 or 4 **characterized in that** the outer side walls (10) of the bush (1) have recesses (14) in the area of the apertures (15).
10. A belt attachment of any of claims 1 to 9 **characterized in that** the plate (21) of the insert (2) has on its upper side wall a projection (271) and the transversal wall of the bush (1) has a hole (17) for receiving the projection (271) when the attachment is in its closed position.
11. A belt attachment of claims 1 to 10 **characterized in that** the bottom (11) of the bush (1) has an opening (18) and on the outer, back surface of the bottom (11) a concentric tooth system is provided around the axis of the opening (18).

Patentansprüche

1. Vorrichtung zur Befestigung an einem Gürtel mit in eine geschlossene und eine geöffnete Position einstellbaren Befestigungsbügeln und einem mit einer Büchse (1) verbundenen Oberbügel (12) und einem Unterbügel (3) **dadurch gekennzeichnet, dass** der Unterbügel (3) mit einer auf einem Gleitstück (2) lösbar angebrachten Auflageplatte (31) versehen ist, so dass die Position des Unterbügels (3) dem Gleit-

- stück (2) gegenüber entlang der Längsachse des Gleitstücks (2) und der Büchse (1) einstellbar ist, wobei das Gleitstück (2) in der Büchse verschiebbare, entlang ihrer Längsachse gelagerte Gleitschuhe (23) und ferner eine Verschlussfeder (4) zur Sicherung des Gleitstücks (2) in der Büchse (1) in einer geschlossenen und mindestens in einer geöffneten Position der Befestigungsvorrichtung aufweist.
2. Vorrichtung zur Befestigung an einem Gürtel nach Anspruch 1 **dadurch gekennzeichnet, dass** die Büchse (1) einen Boden und mit Nuten (13) für Gleitschuhe (23) versehene Seitenwände (10), sowie eine in eine Lippe (121) des Oberbügels (12) übergehende Querwand (19) aufweist.
3. Vorrichtung zur Befestigung an einem Gürtel nach Anspruch 1 **dadurch gekennzeichnet, dass** das Gleitstück (2) aus zwei L-Profilen besteht, die durch eine mittlere Platte (21) verbunden sind, die den Oberteil und den Unterteil des Gleitstücks (2) abgrenzt, wobei der Oberteil einen Raum für die Anknüpfung des Oberbügels (3) und der Unterteil, zwischen den Gleitschuhen (23) einen Raum für die Verschlussfeder (4) definiert.
4. Vorrichtung zur Befestigung an einem Gürtel nach einem der Ansprüche 1 bis 3 **dadurch gekennzeichnet, dass** die Verschlussfeder (4) aus zwei, mit Sperrklinken (46) beendeten, durch einen Querträger verbundenen federnden Armen (42) besteht, und die Gleitschuhen (23) mit Ausschnitten (26) versehen sind und die Seitenwänden der Büchse (1) gegenüberliegende obere Öffnungen (15) und untere Öffnungen (16) für die Sperrklinken (46) aufweisen.
5. Vorrichtung zur Befestigung an einem Gürtel nach Anspruch 3 **dadurch gekennzeichnet, dass** die L-Profilen im Oberteil des Gleitstücks (2) an ihren zugekehrten Seiten mit einer Innenverzahnung (25) und die Auflageplatte (31) des Unterbügels (3) an den gegenüberliegenden Äußerseiten mit entsprechender Außenverzahnung (35) versehen sind.
6. Vorrichtung zur Befestigung an einem Gürtel nach Anspruch 3 oder 5 **dadurch gekennzeichnet, dass** die Platte (21) eine entlang der Längsachse des Gleitstücks (2) angeordnete verlängerte Ausschnitt (20) und die Unterbügel (3) eine Öffnung (33) deren Achse die Achse der Ausschnitt (20) scheidet, aufweist.
7. Vorrichtung zur Befestigung an einem Gürtel nach einem der Ansprüche 1, 2 und 6 **dadurch gekennzeichnet, dass** der Gleitstück (2) an seiner unteren Querseite eine über die Oberfläche der Platte (21) übergreifende Halterung (28) aufweist.
8. Vorrichtung zur Befestigung an einem Gürtel nach Anspruch 4 **dadurch gekennzeichnet, dass** der Querträger (41) der Verschlussfeder (4) einen über die untere Fläche der Armen (42) übergreifenden Griff (44) aufweist.
9. Vorrichtung zur Befestigung an einem Gürtel nach Anspruch 1 oder 4 **dadurch gekennzeichnet, dass** an den inneren Seitenwänden (10) der Büchse (1) im Bereich der Öffnungen (15) Ausnehmungen (14) vorgesehen sind.
10. Vorrichtung zur Befestigung an einem Gürtel nach einem der Ansprüche 1 bis 9 **dadurch gekennzeichnet, dass** die Platte (21) des Gleitstücks (2) in seinem Oberteil einen Vorsprung (271) und die Querwand (19) der Büchse (1) ein Loch (17) für Aufnahme des Vorsprungs (271) in geschlossener Position der Befestigungsvorrichtung aufweist.
11. Vorrichtung zur Befestigung an einem Gürtel nach einem der Ansprüche 1 bis 10 **dadurch gekennzeichnet, dass** der Boden (11) der Büchse (1) eine Öffnung (18) und die äußere hintere Oberfläche des Bodens (11) eine konzentrisch angeordnete Verzahnung aufweist.

Revendications

1. Dispositif d'attache à une ceinture à des étriers de serrage réglables à une position ouverte et à celle fermée comprenant un strier supérieur (12) relié à un boîtier (1) et un étrier inférieur (3), **caractérisé en ce que** l'étrier inférieur (3) comprend un contreplateau (31) qui est monté de manière détachable sur une pièce d'insertion (2) de telle façon que la position de l'étrier inférieur (3) est ajustable en face de la pièce d'insertion (2) le long d'un axe longitudinal de la pièce d'insertion (2) du boîtier (1), la pièce d'insertion comprenant des pattes (23) logées dans le boîtier (1) de manière déplaçable le long de son axe longitudinal et un arrêtoir à bloquer la pièce d'insertion dans une position fermée et une au moins position ouverte du dispositif d'attache.
2. Dispositif d'attache à une ceinture selon la revendication 1, **caractérisé en ce que** le boîtier (1) comprend un fond (11) et de parois latérales (10), dans lesquelles des coulisses (13) pour les pattes (23) sont produites, et une paroi supérieure transversale (19) qui passe, par une courbure (121), à l'étrier supérieur (12).
3. Dispositif d'attache à une ceinture selon la revendication 1, **caractérisé en ce que** la pièce d'insertion (2) est constituée de deux profilés longitudinaux dans la forme de L reliés par 1 intermédiaire d'une

- plaque (21) délimitant une part supérieure et une part inférieure de la pièce d'insertion (2), étant donné que la part supérieure définit un espace pour l'accouplement de l'étrier inférieur (3) et la part inférieure entre les pattes (23) définit un espace pour l'arrêt (4). 5
4. Dispositif d'attache à une ceinture selon l'une quelconque des revendications 1 à 3, **caractérisé en ce que** l'arrêt (4) est constitué de deux bras flexibles (42) terminés par des loquets d'arrêt (46) et reliés par une entretoise (41) étant donné que des encoches opposées (26) sont produites dans les pattes (23) et des orifices supérieurs opposés (15) et des orifices inférieurs opposés (16) pour les loquets d'arrêt (46) sont produits dans les parois latérales (10). 10
15
5. Dispositif d'attache à une ceinture selon la revendication 3, **caractérisé en ce que** les profilés L sont munis, dans la part supérieure de la pièce d'insertion (2), à ses faces intérieures orientées l'une contre l'autre d'une denture intérieure (25) et le contre-plaqueau (31) de l'étrier inférieur (3) est muni, à ses flancs extérieurs opposés, d'une denture extérieure correspondante (35). 20
25
6. Dispositif d'attache à une ceinture selon les revendications 3 ou 5, **caractérisé en ce que** la plaque (1) possède une découpe (20) située à la direction de l'axe de la pièce d'insertion (2) et l'étrier inférieur (3) comporte une ouverture (33) dont l'axe croise l'axe de la découpe (20). 30
7. Dispositif d'attache à une ceinture selon l'une quelconque des revendications 1, 2 et 6, **caractérisé en ce que** la pièce d'insertion (2) comporte, à sa face inférieure transversale, un support (28) débordant une surface supérieure de la plaque (21). 35
8. Dispositif d'attache à une ceinture selon la revendication 4, **caractérisé en ce que** l'entretoise (41) de l'arrêt (4) est munie d'une poignée (44) dépassant une surface inférieure des bras (42). 40
9. Dispositif d'attache à une ceinture selon l'une des revendications 1 ou 4, **caractérisé en ce que** le boîtier comporte, aux parois latérales (10) au niveau des orifices (15), un évidage (L4). 45
10. Dispositif d'attache à une ceinture selon l'une quelconque des revendications à 9, **caractérisé en ce que** la plaque (21) de la pièce d'insertion (2) porte, dans la part supérieure, un saillant (271) et la paroi transversale (19) du boîtier (1) comporte un orifice (17) dans lequel le saillant (121) entre à la position fermée du dispositif d'attache. 50
55
11. Dispositif d'attache à une ceinture selon l'une quel-

conque des revendications 1 à 10, **caractérisé en ce qu'**un orifice (18) est produit dans le fond (11) du boîtier (1) et une denture radiale est réalisée autour de l'axe de l'orifice (18) sur la face arrière extérieure du fond (11).

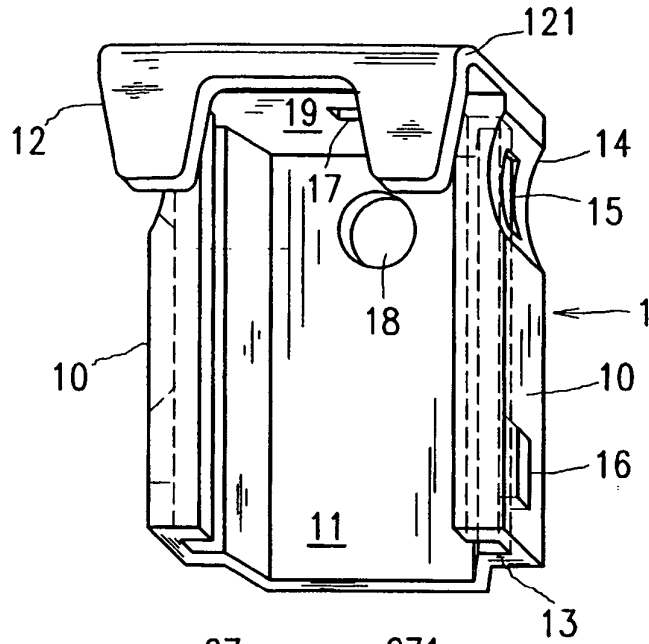

Fig.1

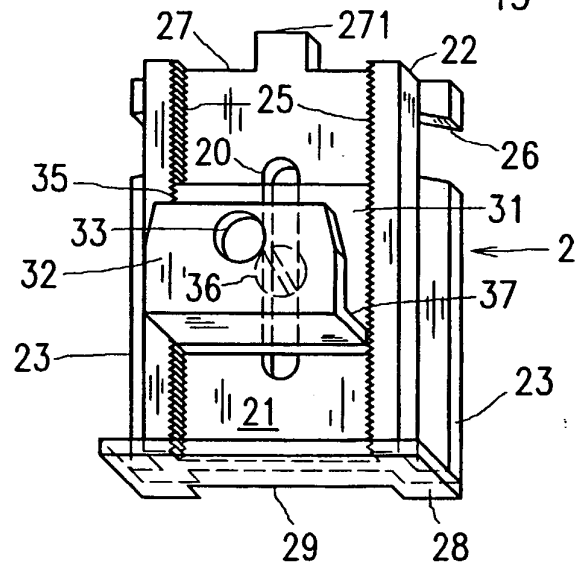

Fig.2

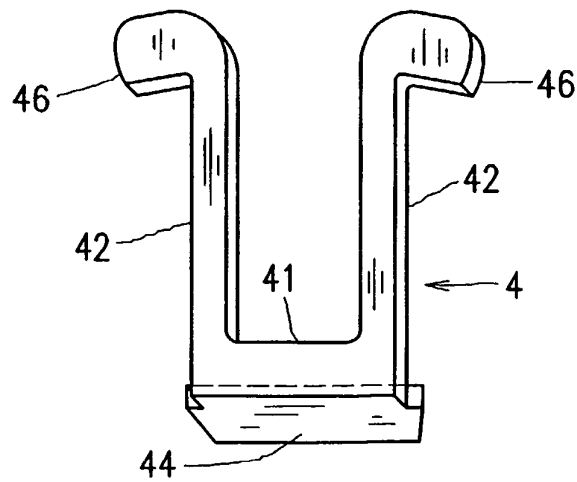

Fig.3

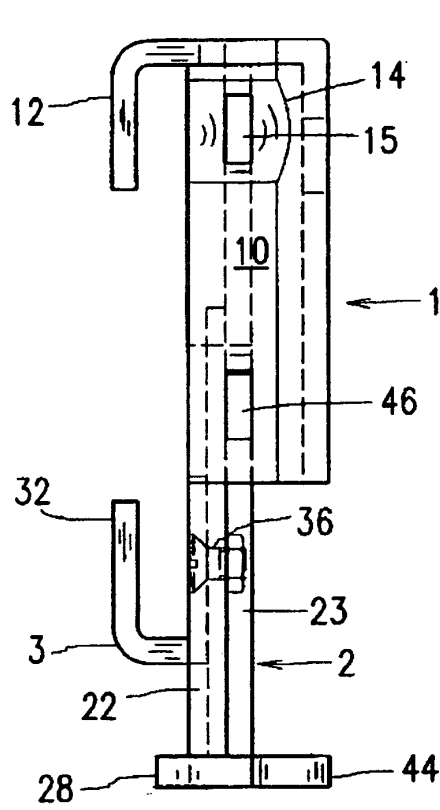

Fig.4

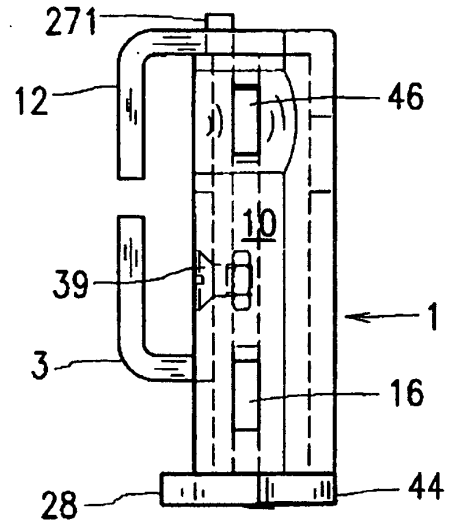

Fig.5

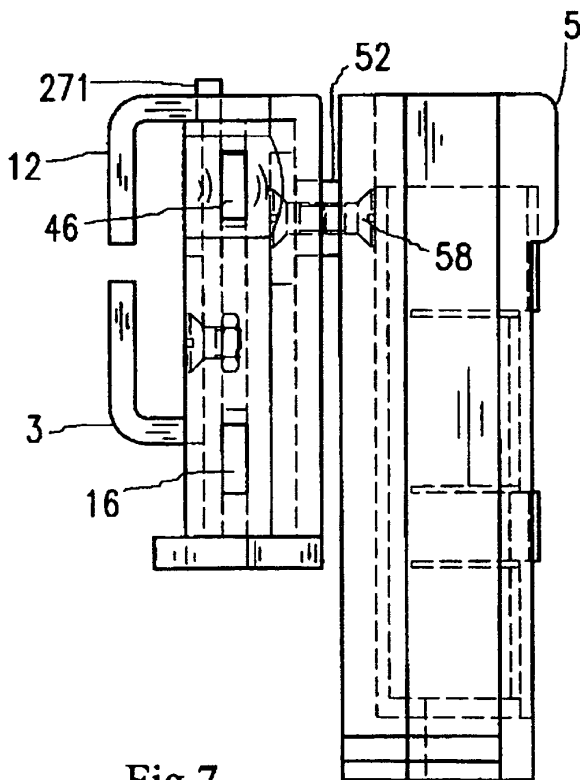

Fig.7

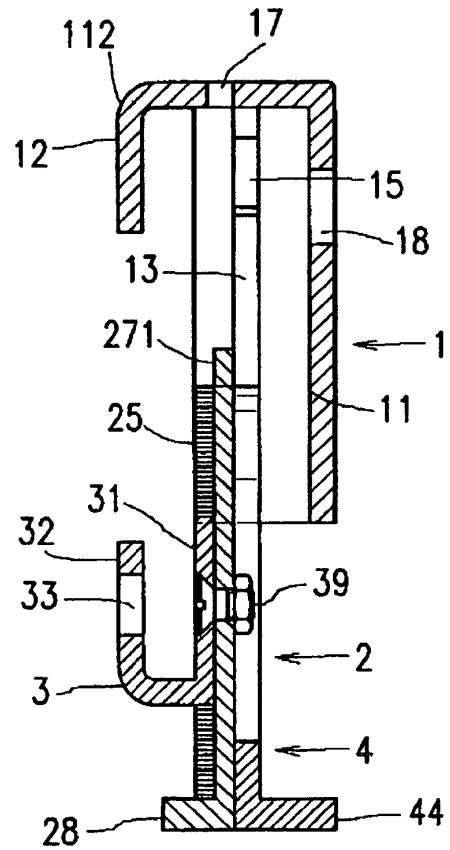

Fig.6

REFERENCES CITED IN THE DESCRIPTION

This list of references cited by the applicant is for the reader's convenience only. It does not form part of the European patent document. Even though great care has been taken in compiling the references, errors or omissions cannot be excluded and the EPO disclaims all liability in this regard.

Patent documents cited in the description

- US 4662552 A [0002]
- US 5893630 A [0003]
- US 6059157 A [0004]
- US 5730348 A [0005]