



- (51) International Patent Classification:  
*H03F 1/32* (2006.01)
- (21) International Application Number:  
PCT/US2014/024999
- (22) International Filing Date:  
12 March 2014 (12.03.2014)
- (25) Filing Language: English
- (26) Publication Language: English
- (30) Priority Data:  
61/783,665 14 March 2013 (14.03.2013) US
- (71) Applicant: **QUANTANCE, INC.** [US/US]; 2800 Campus Drive, Suite 100, San Mateo, CA 94403 (US).
- (72) Inventor: **DROGI, Serge, Francois**; C/o Quantance, Inc., 2800 Campus Drive, Suite 100, San Mateo, CA 94403 (US).
- (74) Agents: **AMSEL, Jason, E.** et al.; Fenwick & West LLP, Silicon Valley Center, 801 California Street, Mountain View, CA 94041 (US).
- (81) Designated States (unless otherwise indicated, for every kind of national protection available): AE, AG, AL, AM,

AO, AT, AU, AZ, BA, BB, BG, BH, BN, BR, BW, BY, BZ, CA, CH, CL, CN, CO, CR, CU, CZ, DE, DK, DM, DO, DZ, EC, EE, EG, ES, FI, GB, GD, GE, GH, GM, GT, HN, HR, HU, ID, IL, IN, IR, IS, JP, KE, KG, KN, KP, KR, KZ, LA, LC, LK, LR, LS, LT, LU, LY, MA, MD, ME, MG, MK, MN, MW, MX, MY, MZ, NA, NG, NI, NO, NZ, OM, PA, PE, PG, PH, PL, PT, QA, RO, RS, RU, RW, SA, SC, SD, SE, SG, SK, SL, SM, ST, SV, SY, TH, TJ, TM, TN, TR, TT, TZ, UA, UG, US, UZ, VC, VN, ZA, ZM, ZW.

- (84) Designated States (unless otherwise indicated, for every kind of regional protection available): ARIPO (BW, GH, GM, KE, LR, LS, MW, MZ, NA, RW, SD, SL, SZ, TZ, UG, ZM, ZW), Eurasian (AM, AZ, BY, KG, KZ, RU, TJ, TM), European (AL, AT, BE, BG, CH, CY, CZ, DE, DK, EE, ES, FI, FR, GB, GR, HR, HU, IE, IS, IT, LT, LU, LV, MC, MK, MT, NL, NO, PL, PT, RO, RS, SE, SI, SK, SM, TR), OAPI (BF, BJ, CF, CG, CL, CM, GA, GN, GQ, GW, KM, ML, MR, NE, SN, TD, TG).

**Published:**

— with international search report (Art. 21(3))

WO 2014/159753 A1

(54) Title: ET SYSTEM WITH ADJUSTMENT FOR NOISE

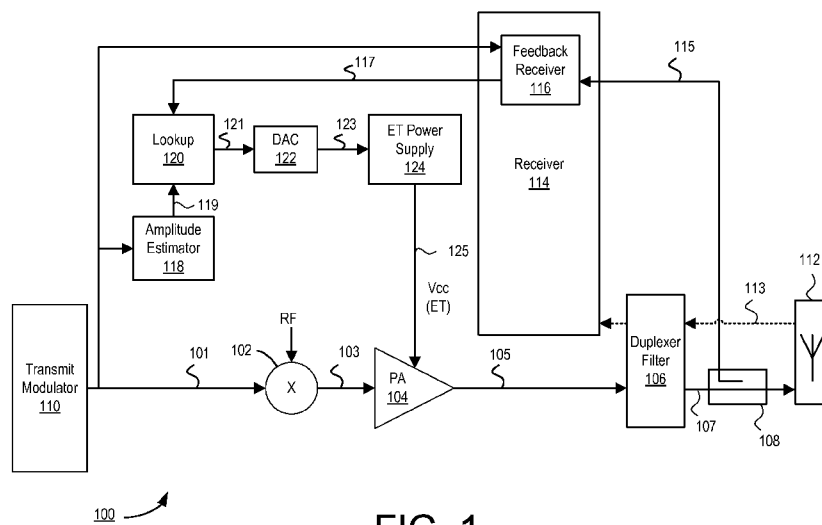

FIG. 1

(57) Abstract: An envelope tracking transceiver dynamically adjusts envelope tracking parameters to achieve the desired tradeoff between noise performance and power efficiency. When higher levels of noise are acceptable, the envelope tracking transceiver dynamically adjusts transmitter parameters to achieve better power efficiency while sacrificing noise performance. When lower levels of noise are desired, the envelope tracking transceiver dynamically adjusts parameters to achieve better noise performance while sacrificing efficiency.

## ET SYSTEM WITH ADJUSTMENT FOR NOISE

INVENTOR: SERGE FRANCOIS DROGI

## CROSS-REFERENCE TO RELATED APPLICATIONS

[0001] This application claims the benefit of U.S. Provisional Patent Application No. 61/783,665 filed on March 14, 2013, entitled “ET System with Adjustment for Noise,” which is incorporated by reference herein in its entirety.

## BACKGROUND

[0002] This disclosure relates generally to a radio frequency transceiver, and more, specifically to an envelope tracking system in a radio frequency transceiver.

[0003] Envelope Tracking (ET) systems are commonly utilized in the radio frequency (RF) transmitter section of a radio where power efficiency is important such as in cellular radios used in mobile phones. A typical ET system includes an RF power amplifier (PA) utilizing a variable power supply, which supplies the PA with a dynamically changing supply voltage that tracks the amplitude of the modulation. The goal of such an ET system is generally to improve efficiency by operating the PA with low headroom.

## SUMMARY

[0004] Embodiments include an envelope tracking transceiver that adjusts envelope tracking parameters to achieve desired noise performance and power efficiency. In a first embodiment, an envelope tracking transceiver comprises a power amplifier, a lookup circuit, a power supply, a receiver, and a configuration circuit. The power amplifier receives an input signal and generates an amplified output signal. The power amplifier also receives a supply voltage providing power to the power amplifier. The lookup circuit generates a power supply control signal based on an estimated amplitude of the input signal and a feedback signal indicating a compression level for operating the power amplifier. The power supply provides the supply voltage to the power amplifier based on the power supply control signal. The receiver receives a receive signal and generates a noise margin signal representative of a noise margin of the receive signal. The configuration circuit generates the feedback signal based on the noise margin signal.

[0005] In a second embodiment, the envelope tracking transceiver comprises a power amplifier, a lookup circuit, a power supply, a receiver, and a configuration circuit. The power amplifier receives an input signal and generates an amplified output signal. The power

amplifier also receives a supply voltage providing power to the power amplifier. The lookup circuit generates a power supply control signal based on an estimated amplitude of the input signal. The power supply provides the supply voltage to the power amplifier based on the power supply control signal. The receiver receives a receive signal and generates a noise margin signal representative of a noise margin of the receive signal. The configuration circuit generates one or more control signals to control parameters of at least one of the power amplifier, the lookup circuit, and the power supply based on the noise margin signal.

**[0006]** In a third embodiment, the envelope tracking transceiver comprises a power amplifier, a lookup circuit, a power supply, and a feedback receiver. The power amplifier receives an input signal and generates an amplified output signal. The power amplifier also receives a supply voltage providing power to the power amplifier. The lookup circuit generates a power supply control signal based on an estimated amplitude of the input signal and a feedback signal indicating a compression level for operating the power amplifier. The power supply provides the supply voltage to the power amplifier based on the power supply control signal. The feedback receiver generates a noise measure in the amplified output signal and generates the feedback signal responsive to the noise measure.

**[0007]** The features and advantages described in the specification are not all inclusive and, in particular, many additional features and advantages will be apparent to one of ordinary skill in the art in view of the drawings and specification. Moreover, it should be noted that the language used in the specification has been principally selected for readability and instructional purposes, and may not have been selected to delineate or circumscribe the inventive subject matter.

#### BRIEF DESCRIPTION OF THE DRAWINGS

**[0008]** The teachings of the embodiments disclosed herein can be readily understood by considering the following detailed description in conjunction with the accompanying drawings.

**[0009]** Figure (FIG.) 1 is a circuit diagram illustrating a first embodiment of an ET transceiver.

**[0010]** FIG. 2 is a circuit diagram illustrating a second embodiment of an ET transceiver.

#### DETAILED DESCRIPTION

**[0011]** The Figures (FIG.) and the following description relate to various embodiments by way of illustration only. It should be noted that from the following discussion, alternative

embodiments of the structures and methods disclosed herein will be readily recognized as viable alternatives that may be employed without departing from the principles discussed herein.

**[0012]** Reference will now be made in detail to several embodiments, examples of which are illustrated in the accompanying figures. It is noted that wherever practicable similar or like reference numbers may be used in the figures and may indicate similar or like functionality. The figures depict various embodiments for purposes of illustration only. One skilled in the art will readily recognize from the following description that alternative embodiments of the structures and methods illustrated herein may be employed without departing from the principles described herein.

**[0013]** An envelope tracking transceiver dynamically adjusts envelope tracking parameters to achieve the desired tradeoff between noise performance and power efficiency. Particularly, better power efficiency of the transmitter can be obtained by sacrificing noise performance of the transmitted and received signals of the transceiver. When higher levels of noise are acceptable, the envelope tracking transceiver dynamically adjusts transmitter parameters to achieve better power efficiency while sacrificing noise performance. When lower levels of noise are desired, the envelope tracking transceiver dynamically adjusts parameters to achieve better noise performance while sacrificing efficiency.

**[0014]** FIG. 1 illustrates an embodiment of an RF transceiver 100 with an ET system. Transmit modulator 110 generates a digital transmit signal 101, which is upconverted by RF upconverter 102 to upconverted input signal 103 provided to the input of PA 104. PA 104 amplifies upconverted input signal 103 to generate amplified RF signal 105. The amplified RF signal 105 from PA 104 reaches antenna 112 as output signal 107 after passing through duplexer filter 106. Antenna 112 also receives a receive signal 113 which reaches receiver 114 after passing through duplexer filter 106. Duplexer filter 106 provides filtering between amplified RF signal 105 and a received signal 113 received by antenna 112. Coupler 108 provides a feedback signal 115 to feedback receiver 116 that is representative of output signal 107.

**[0015]** Digital transmit signal 101 is also provided to amplitude estimator 118 which estimates the amplitude of digital transmit signal 101. For example, in one embodiment, amplitude estimator 118 estimates the amplitude based on the equation  $\text{Amplitude} = \sqrt{I^2 + Q^2}$ , where I and Q are the inphase and quadrature components respectively of the digital transmit signal 101. An estimated amplitude signal 119 is provided as an index to lookup table 120, which outputs signal 121 based on the estimated amplitude signal 119 and a

feedback signal 117 from feedback receiver 116. Lookup table 120 may be populated with PA supply voltage values which are appropriate for various values of estimated transmit signal amplitude signal 119 and feedback signal 117, typically determined through PA characterization.

**[0016]** Digital-to-analog converter (DAC) 122 converts the outputted PA supply voltage values from lookup table 120 to an analog signal 123, which controls ET power supply 124 to output specific voltages via supply voltage 125 to PA 104, so that PA 104 may operate with low headroom for good efficiency. In one embodiment, a delay alignment circuit (not shown) inserts a time delay at ET power supply 124 or within RF upconverter 102 to ensure proper time alignment between supply voltage 125 provided by ET power supply 124 and the amplified RF signal 105 at the output of PA 104.

**[0017]** The values in lookup table 120 may be adjusted for a desired level of compression specified by feedback signal 117. Compression refers to the voltage operating headroom of PA 104. For example, in one embodiment, values in lookup table 120 are adjusted by multiplying values in lookup table 120 by a value  $x$ . Compression increases when  $x$  is less than 1 and decreases when  $x$  is greater than 1. For example, if  $x=0.9$ , the supply voltage 125 supplied to PA 104 is effectively decreased by 10%. If  $x=1.1$ , the supply voltage 125 supplied to PA 104 is effectively increased by 10%. The desired compression levels are typically determined by PA and system characterization. For good efficiency, PA 104 may be operated with a high compression level, but the output signal from PA 104 should not exceed a level of acceptable distortion. Otherwise, if the acceptable level of distortion is exceeded, the compression level should be lowered until the acceptable level of distortion is met. Adjacent channel power (ACP) is a common indicator of distortion in PAs. Alternatively, instead of feedback signal 117 adjusting values in the lookup table 120, the feedback signal 117 may instead adjust a parameter of the amplitude estimator 118 to control compression. For example, the output of the amplitude estimator may be multiplied by the value  $x$  to increase compression when  $x$  is less than 1 and decrease compression when  $x$  is greater than 1.

**[0018]** Feedback receiver 116 generates feedback signal 117 to control compression based on transmit signal 101 and coupled signal 115 received via coupler 108. Feedback receiver 116 either operates continuously during normal transmitter operation, periodically during transmitter operation, or operates during a calibration mode. Feedback receiver 116 downconverts coupled signal 115 to recover a downconverted baseband signal. Feedback receiver 116 evaluates the downconverted signal, and measures distortion in signal 115, representative of distortion in output signal 107. For example, in one embodiment, feedback

receiver 116 calculates ACP by observing the power in the adjacent channel (for example, by performing a fast Fourier transform and taking the ratio of the power of the desired frequency channel of signal 115 to the power of the adjacent channels). In one embodiment, feedback receiver 116 measures an error in the trajectory of coupled signal 115 as compared with the desired, baseband transmit signal 101 as generated by transmit modulator 110, calculating the difference in these signals utilizing, for example, least-mean-squared techniques. Based on such distortion assessments, feedback receiver 116 provides feedback signal 117 to adjust the values in lookup table 120 to adjust the compression level just low enough to ensure distortion levels are acceptable.

**[0019]** In ET systems such as the transceiver 100 of FIG. 1, PA 104 may generate some noise outside the desired RF transmit band. The noise is generated due to a number of factors, including (a) AM-AM and AM-PM characteristics inherent in PA 104, (b) nonlinearities caused by operating PA 104 with low supply voltage headroom, (c) imperfections in the PA model for generating the variable power supply voltage, and (d) bandwidth limitations in the ET power supply 124.

**[0020]** In particular, noise generated in the RF receive band can desensitize the RF receiver 114 of the transceiver to the receive signal 113. In cellular radios used in mobile phones, the radio system is often full duplex (the RF receiver 114 operates at the same time as the transmitter). Thus noise generated by PA 104 can feed into receiver 114 during operation. Increased compression of PA 104 may increase noise in the receive band of receive signal 113. Duplexer filter 106 functions to limit this noise, but the filtering may be insufficient.

**[0021]** FIG. 2 illustrates a second embodiment of a ET transceiver 200 in which parameters of the envelope tracking system are adjusted as a function of the tolerable noise in the receive path (receive noise margin), in order to limit the desensitization of the RF receiver 114. The system is similar to that of FIG. 1, but includes a configuration block 254 and noise margin estimator 252, and omits some details previously described.

**[0022]** The radio link quality is typically monitored in modern radio systems, e.g., by a noise margin estimator 252. The link quality may be assessed using parameters of the radio link such as receive signal strength, or bit or frame error rates. Thus the noise margin estimator 252 can estimate the receive noise margin at the RF receiver 114 and can provide one or more feedback signals 251, 253 to a configuration block 254 that adjusts the parameters of the envelope tracking system accordingly.

**[0023]** The receive noise margin will typically change dynamically, as radio conditions change. For example, many systems operate with high receive noise margins when the

transmitter is used for high data rate transmission; the highest data rates will rarely be used in poor or marginal receive conditions. It is at these high data rates where the transmitter will operate at the highest power levels; thus substantial overall power savings are realized from an efficient PA. Under these conditions, the configuration block 254 adjusts the parameters of the ET system to maximize efficiency, while allowing higher than nominal receive band noise since the receive noise margin is high. Conversely, when radio conditions are poor, and the receive noise margin is low, the configuration block 254 adjusts the parameters of the ET system to minimize receive band noise, even at the expense of degraded PA efficiency.

**[0024]** In one embodiment, noise margin estimator 252 provides a receive signal strength indicator (RSSI) level 251 to configuration block 254 as an estimate of the receive noise margin. When a high level of RSSI is detected via signal 251 (e.g., above a threshold noise margin), configuration block 254 adjusts the parameters of the ET system to increase efficiency, even at the expense of receive band noise, since a high level of RSSI corresponds to a high receive noise margin at the RF receiver's input, and additional noise can be tolerated. For example, in one embodiment, configuration block 254 may adjust parameters in the lookup table 120 to increase compression, reduce filtering in the ET power supply 124 via control signal 257, and/or adjust biasing of the power amplifier via control signal 259. Effects of these adjustments on receive band noise and efficiency are described in further detail below.

**[0025]** Conversely, if a low level of RSSI is detected via signal 251 (e.g., below the threshold noise margin), configuration block 254 adjusts the parameters of the ET system to decrease receive band noise, even at the expense of efficiency, since a low level of RSSI corresponds to a low receive noise margin at the RF receiver's input, and much additional noise cannot be tolerated. For example, in one embodiment, configuration block 254 may adjust parameters in the lookup table 120 to decrease compression, increase filtering in the ET power supply 124 via control signal 257, and/or adjust biasing of the power amplifier via control signal 259. Effects of these adjustments on receive band noise and efficiency are described in further detail below.

**[0026]** In another embodiment, the noise margin estimator 252 detects if the system is in the presence of a public safety network. This indication may be communicated to the radio through a cellular basestation. In this case, additional emissions and noise requirements may be imposed on the radio. In one embodiment, the noise margin estimator 252 provides a public safety indicator (PSI) signal 253 to configuration block 254 which indicates to configuration block 254 that emissions and noise from PA 104 should be reduced.

Configuration block 254 may adjust ET parameters in order to reduce emissions and noise, while trading off efficiency.

**[0027]** In yet other embodiments, a different signal representative of the noise margin can be provided to the configuration block 254, such as, for example, a signal representing a bit or frame error rate, or a signal representing a combination of the above described factors.

**[0028]** Configuration block 254 can adjust various parameters of the ET system based on the noise margin. For example, configuration block 254 may increase or reduce the compression of PA 104 via the lookup table 120 via feedback signal 255 to increase or decrease efficiency (with a corresponding increase or decrease in receive noise), as described earlier.

Alternatively, the configuration block 254 may control compression by adjusting a parameter of the amplitude estimator 118 as described earlier.

**[0029]** A less compressed PA sees its gain vary less with the supply voltage applied. Thus, errors in the path from lookup table 120 to supply voltage 125 which supplies PA 104, which normally cause noise and distortion when they erroneously vary the gain of PA 104, cause less noise and distortion when PA 104 is less compressed. However, when PA 104 is less compressed, PA 104 operates with lower efficiency. Conversely, a more compressed PA sees its gain vary more with the voltage applied. Thus, errors in the supply voltage for PA 104 cause more noise and distortion when PA 104 is more compressed. However, when PA 104 is more compressed, PA 104 operates with higher efficiency.

**[0030]** Configuration block 254 may also adjust the filtering of the voltage control signal 123 in ET power supply 124 via filtering control signal 257. Filtering is used to limit the control bandwidth to envelope tracking power supply 124, which reduces noise because it prevents envelope tracking power supply 124 from attempting to generate rapid voltage changes to PA 104. Without the filtering, these rapid voltage changes are generated with inaccuracy due to inherent bandwidth limitations within the envelope tracking power supply 124, causing PA 104 to generate noise. However, reducing filtering allows envelope tracking power supply 124 to achieve lower supply voltages to PA 104, increasing efficiency. Thus, configuration block 254 may command greater or less filtering of voltage control signal 123 when a low or high receive noise margin, respectively, is indicated.

**[0031]** Configuration block 254 may also adjust the biasing of PA 104 via a bias control signal 259. Controlling the bias of PA 104 changes its AM/AM and AM/PM characteristics. Some AM/AM shapes can be more susceptible to the generation of noise, but also have higher efficiency.

[0032] Configuration block 254 may also disable the dynamic ET system altogether, commanding envelope tracking power supply 124 to provide a static supply voltage to PA 104. This may be accomplished by adjusting lookup table 120 to provide the same PA supply voltage value regardless of transmit power. Alternatively, the PA supply voltage may be held constant during certain transmit periods, and changed between periods if the output power of PA 104 changes. Disabling the dynamic ET system in this way reduces noise associated with the envelope power supply 124, and can be commanded by configuration block 254 if a low receive noise margin is indicated.

[0033] Upon reading this disclosure, those of skill in the art will appreciate still additional alternative designs for an envelope tracking system with adjustment for noise. Thus, while particular embodiments and applications have been illustrated and described, it is to be understood that the embodiments discussed herein are not limited to the precise construction and components disclosed herein and that various modifications, changes and variations which will be apparent to those skilled in the art may be made in the arrangement, operation and details of the method and apparatus disclosed herein without departing from the scope of the disclosure.

What is claim is:

1. An envelope tracking transceiver comprising:
  - a power amplifier to receive an input signal and generate an amplified output signal, the power amplifier receiving a supply voltage providing power to the power amplifier;
  - a lookup circuit to generate a power supply control signal based on an estimated amplitude of the input signal and a feedback signal indicating a compression level for operating the power amplifier;
  - a power supply to provide the supply voltage to the power amplifier based on the power supply control signal;
  - a receiver to receive a receive signal and to generate a noise margin signal representative of a noise margin of the receive signal; and
  - a configuration circuit to generate the feedback signal based on the noise margin signal.
2. The envelope tracking transceiver of claim 1, wherein the noise margin signal is based on a receive signal strength indicator indicating a strength of the received signal at the receiver.
3. The envelope tracking transceiver of claim 1, wherein the noise margin signal is based on a public safety indicator indicating that the receiver is communicating with a public safety network having specific noise specifications.
4. The envelope tracking transceiver of claim 1, wherein the noise margin signal is based on an error rate of the receive signal.
5. The envelope tracking transceiver of claim 1, wherein the configuration circuit is further configured to generate a filter control signal to increase filtering of the power supply control signal responsive to the noise margin signal indicating a decrease in the noise margin, and to decrease filtering of the power supply control signal responsive to the noise margin signal indicating an increase in the noise margin.
6. The envelope tracking transceiver of claim 1, wherein the configuration circuit is further configured to generate a bias control signal to adjust a bias of the power amplifier to increase a noise susceptibility of the power amplifier responsive to the noise margin signal indicating an increase in the noise margin, and to adjust the bias of the power

amplifier to decrease the noise susceptibility of the power amplifier response to the noise margin signal indicating a decrease in the noise margin.

7. The envelope tracking transceiver of claim 1, wherein the configuration circuit is further configured to generate a control signal that causes the ET power supply to hold the supply voltage constant during one or more transmit periods responsive to the noise margin signal indicating a decrease in the noise margin.
8. The envelope tracking transceiver of claim 1, wherein the configuration circuit is configured to generate the feedback signal to increase the compression level responsive to the noise margin increasing, and to decrease the compression level responsive to the noise margin decreasing.
9. An envelope tracking transceiver comprising:
  - a power amplifier to receive an input signal and generate an amplified output signal, the power amplifier receiving a supply voltage providing power to the power amplifier;
  - a lookup circuit to generate a power supply control signal based on an estimated amplitude of the input signal;
  - a power supply to provide the supply voltage to the power amplifier based on the power supply control signal;
  - a receiver to receive a receive signal and to generate a noise margin signal representative of a noise margin of the receive signal; and
  - a configuration circuit to generate one or more control signals to control parameters of at least one of the power amplifier, the lookup circuit, and the power supply based on the noise margin signal.
10. The envelope tracking transceiver of claim 9, wherein the one or more control signals control the parameters to increase power efficiency of the power amplifier responsive to the noise margin increasing, and wherein the one or more control signals control the parameters to reduce noise in the amplified output signal responsive to the noise margin decreasing.
11. The envelope tracking transceiver of claim 9, wherein the noise margin signal is based on a receive signal strength indicator indicating a strength of the received signal at the receiver.

12. The envelope tracking transceiver of claim 9, wherein the noise margin signal is based on a public safety indicator indicating that the receiver is communicating with a public safety network having specific noise specifications.
13. The envelope tracking transceiver of claim 9, wherein the noise margin signal is based on an error rate of the receive signal.
14. The envelope tracking transceiver of claim 9, wherein the configuration circuit is further configured to generate a filter control signal to increase filtering of the power supply control signal responsive to the noise margin signal indicating a decrease in the noise margin, and to decrease filtering of the power supply control signal responsive to the noise margin signal indicating an increase in the noise margin.
15. The envelope tracking transceiver of claim 9, wherein the configuration circuit is further configured to generate a bias control signal to increase a noise susceptibility of the power amplifier responsive to the noise margin signal indicating an increase in the noise margin, and to adjust the bias of the power amplifier to decrease the noise susceptibility of the power amplifier response to the noise margin signal indicating a decrease in the noise margin.
16. An envelope tracking transceiver comprising:
  - a power amplifier to receive an input signal and generate an amplified output signal, the power amplifier receiving a supply voltage providing power to the power amplifier;
  - a lookup circuit to generate a power supply control signal based on an estimated amplitude of the input signal and a feedback signal indicating a compression level for operating the power amplifier;
  - a power supply to provide the supply voltage to the power amplifier based on the power supply control signal;
  - a feedback receiver to generate a noise measure in the amplified output signal and to generate the feedback signal responsive to the noise measure.
17. The envelope tracking transceiver of claim 16, wherein the feedback receiver is configured to determine the noise measure based on the input signal and a signal representative of the amplified output signal.

18. The envelope tracking transceiver of claim 17, wherein the feedback receiver is further configured to downsample the signal representative of the amplified output signal and perform a comparison between the downsampled signal and the input signal.
19. The envelope tracking transceiver of claim 16, wherein the noise measure represents an adjacent channel power.
20. The envelope tracking transceiver of claim 16, wherein the feedback signal increases the compression level responsive to the noise measure falling below an acceptable distortion level, and decreases the compression level responsive to the noise measure exceeding the acceptable distortion level.

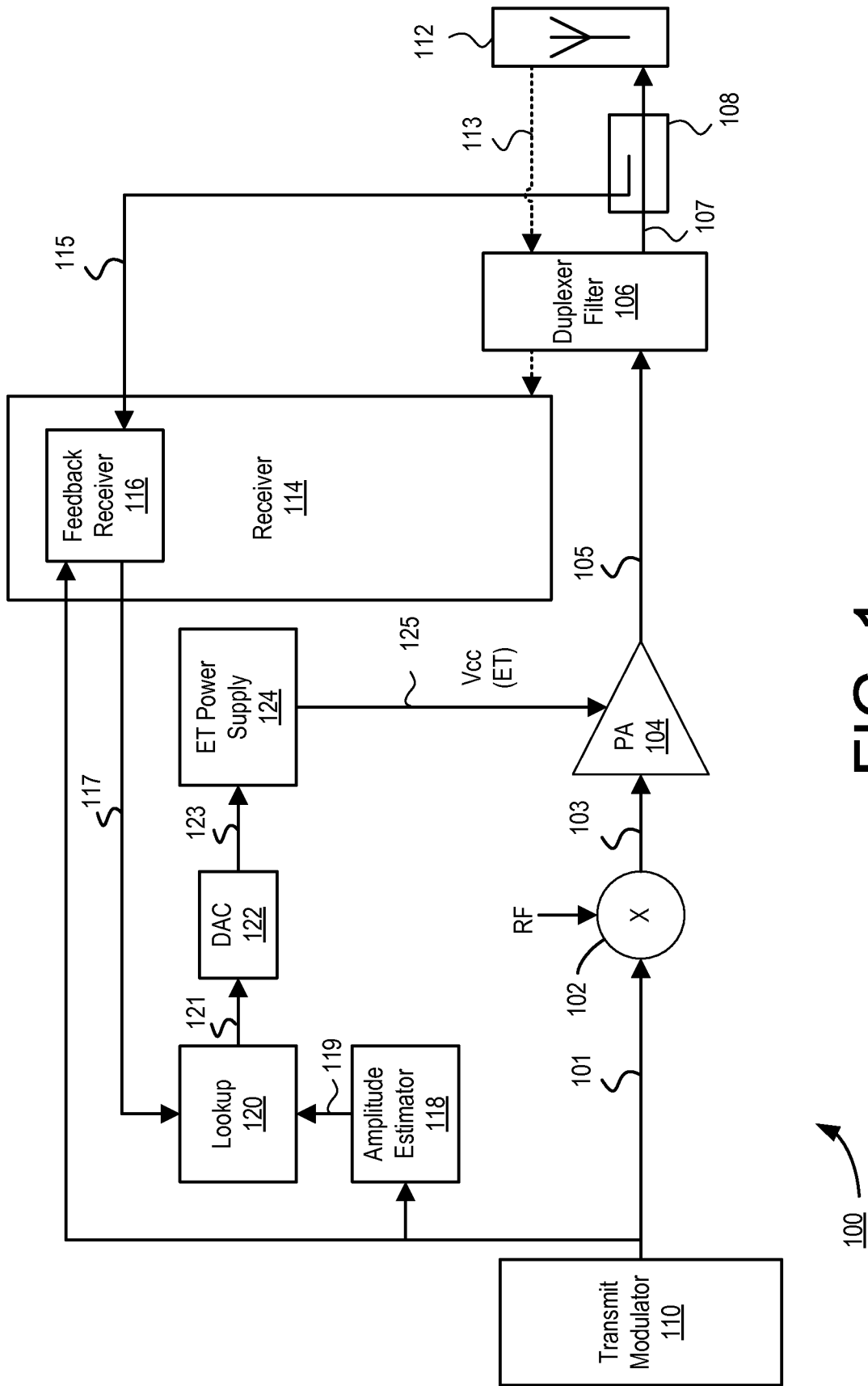

FIG. 1

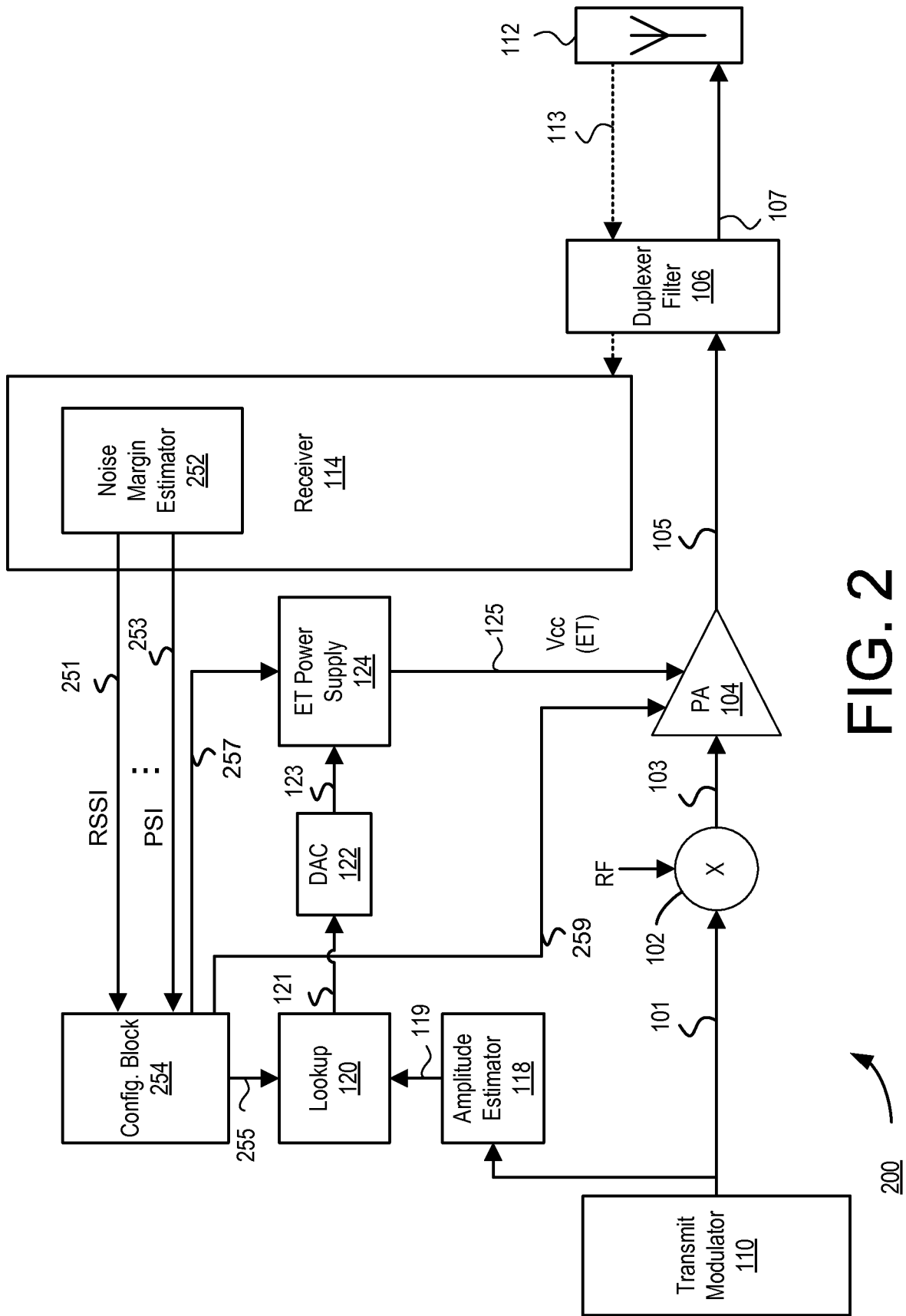

FIG. 2

## INTERNATIONAL SEARCH REPORT

International application No.

PCT/US2014/024999

<b>A. CLASSIFICATION OF SUBJECT MATTER</b> IPC(8) - H03F1/32 (2014.01) USPC - 330/127 According to International Patent Classification (IPC) or to both national classification and IPC		
<b>B. FIELDS SEARCHED</b> Minimum documentation searched (classification system followed by classification symbols) IPC(8) - H03F1/32; H03G3/20; H03G3/20; G05F1/00(2014.01) USPC - 330/127, 131, 149; 323/283; 455/127.1 Documentation searched other than minimum documentation to the extent that such documents are included in the fields searched CPC - H03F2200/102; H03G3/3042; H03F1/0222 (2014.02) Electronic data base consulted during the international search (name of data base and, where practicable, search terms used) PatBase, Google Patents, Google Scholar,		
<b>C. DOCUMENTS CONSIDERED TO BE RELEVANT</b>		
Category*	Citation of document, with indication, where appropriate, of the relevant passages	Relevant to claim No.
Y	US 2012/0200354 A1 (RIPLEY et al.) 09 August 2012 (09.08.2012) entire document	1-20
Y	US 2010/0266137 A1 (SIBBALD et al.) 21 October 2010 (21.10.2010) entire document	1-8, 10, 15
Y	US 2006/0209944 A1 (CARBALLO et al.) 21 September 2006 (21.09.2006) entire document	5, 7-15, 20
Y	US 2012/0326686 A1 (DIA et al.) 27 December 2012 (27.12.2012) entire document	16-20
<input type="checkbox"/> Further documents are listed in the continuation of Box C. <input type="checkbox"/>		
* Special categories of cited documents: "A" document defining the general state of the art which is not considered to be of particular relevance "E" earlier application or patent but published on or after the international filing date "L" document which may throw doubts on priority claim(s) or which is cited to establish the publication date of another citation or other special reason (as specified) "O" document referring to an oral disclosure, use, exhibition or other means "P" document published prior to the international filing date but later than the priority date claimed "T" later document published after the international filing date or priority date and not in conflict with the application but cited to understand the principle or theory underlying the invention "X" document of particular relevance; the claimed invention cannot be considered novel or cannot be considered to involve an inventive step when the document is taken alone "Y" document of particular relevance; the claimed invention cannot be considered to involve an inventive step when the document is combined with one or more other such documents, such combination being obvious to a person skilled in the art "&" document member of the same patent family		
Date of the actual completion of the international search 25 June 2014		Date of mailing of the international search report <b>14 JUL 2014</b>
Name and mailing address of the ISA/US Mail Stop PCT, Attn: ISA/US, Commissioner for Patents P.O. Box 1450, Alexandria, Virginia 22313-1450 Facsimile No. 571-273-3201		Authorized officer: Blaine R. Copenheaver PCT Helpdesk: 571-272-4300 PCT OSP: 571-272-7774