

Smith & Lane,

Saw-mill,

No 24,913,

Patented July 26, 1859.

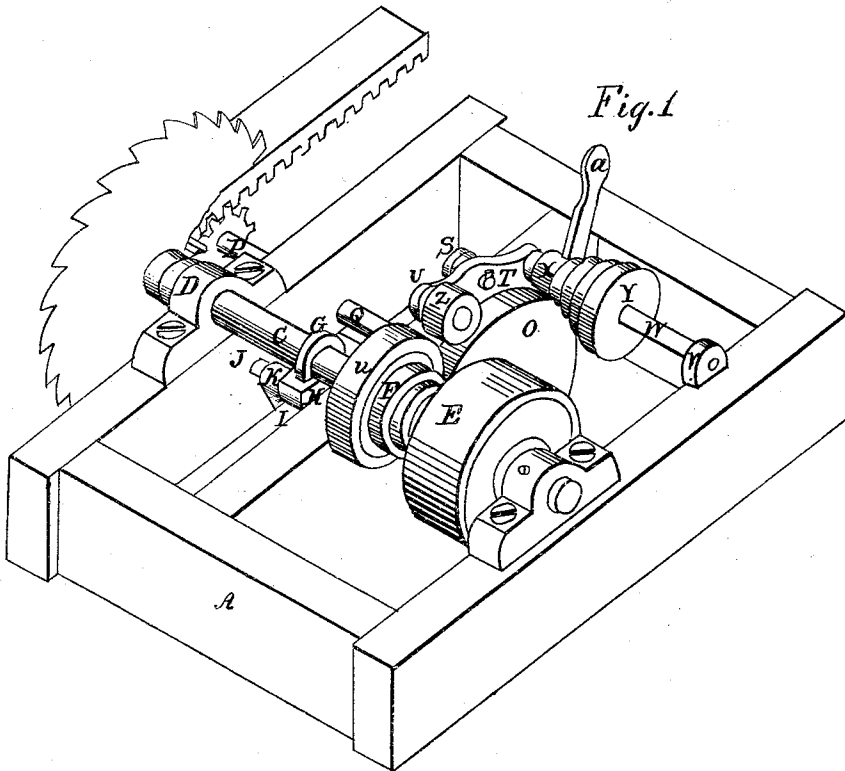

Fig. 1

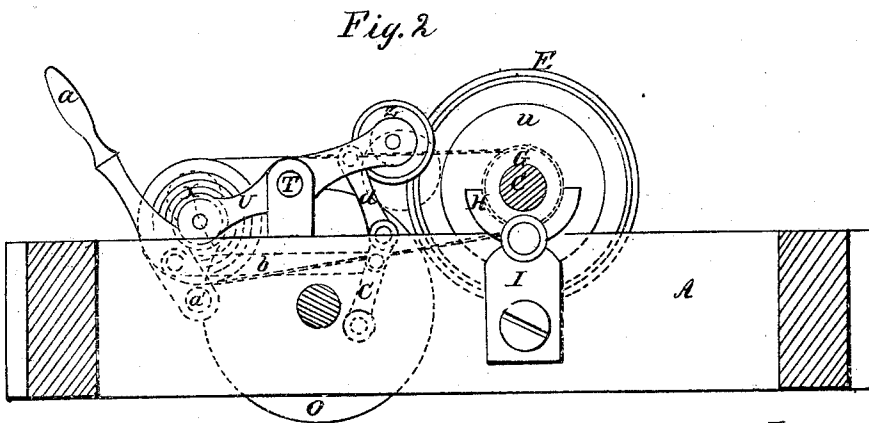

Fig. 2

Witnesses  
Geo. H. Knight  
Francis Mulford

Inventor  
S. R. Smith  
P. P. Lane

Smith & Lane,  
Saw-mill,

Sheet 2. 2 Sheets

No 24, 913,

Patented July 26, 1859.

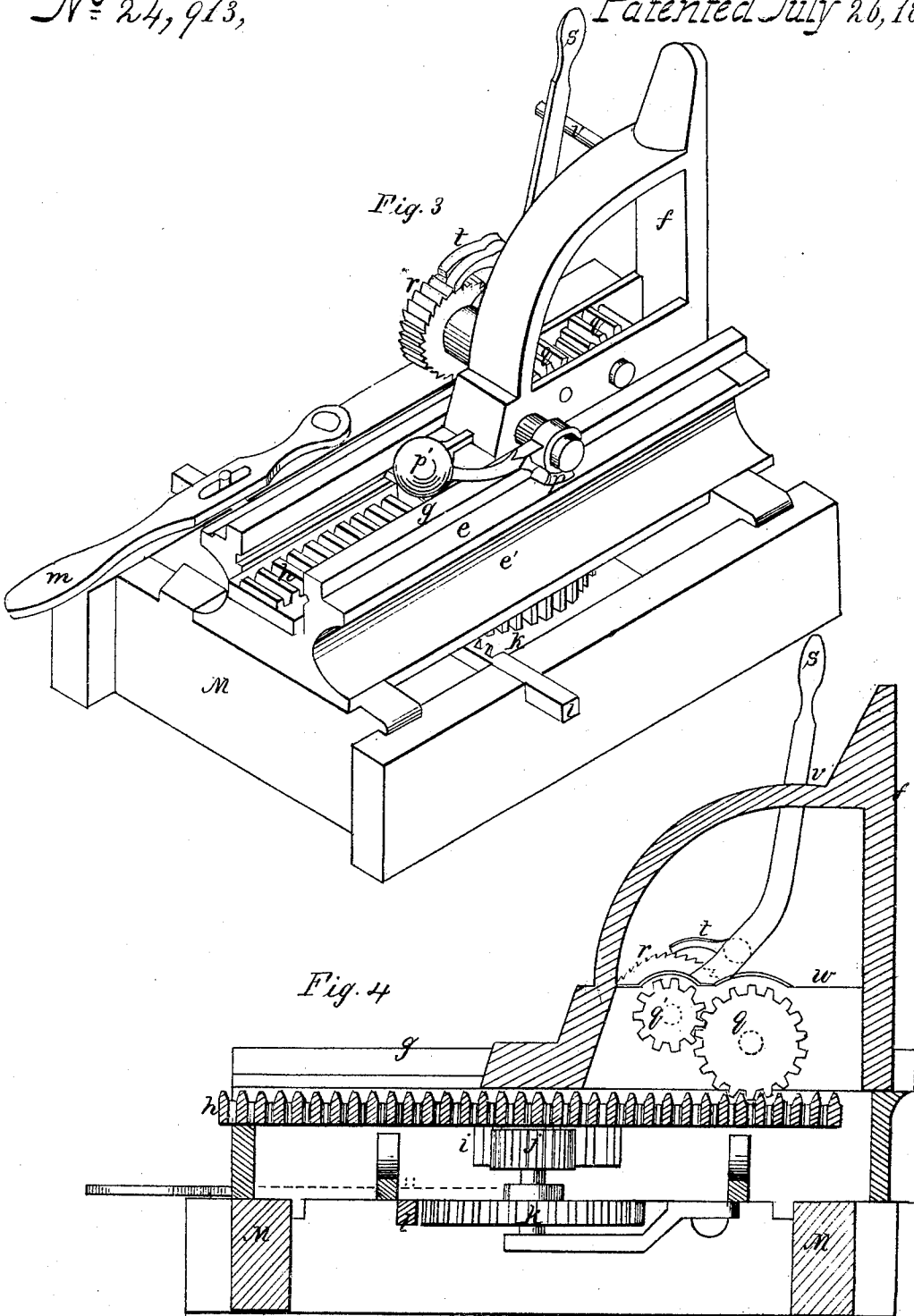

Witnesses  
Geo. H. Smith  
Francis Millard

Inventor  
S. R. Smith  
P. P. Lane

# UNITED STATES PATENT OFFICE.

SAMUEL R. SMITH AND PHILANDER P. LANE, OF CINCINNATI, OHIO, ASSIGNORS TO LANE AND BODLEY.

## PORTABLE SAWING-MACHINE.

Specification of Letters Patent No. 24,913, dated July 26, 1859.

To all whom it may concern:

Be it known that we, SAMUEL R. SMITH and PHILANDER P. LANE, both of Cincinnati, Hamilton county, Ohio, have invented new and useful Improvements in Circular Saw-mills; and we hereby declare the following to be a full and exact description of the same, reference being had to the accompanying drawings, making part of this specification.

This invention relates to the class known as portable saw mills having all its parts within the compass of a single frame and consists in 1st, an arrangement for prompt and effective feeding and gigging back of the log; 2nd, an arrangement of mechanism for convenient and accurate setting of the log; 3rd, provision for prevention of clogging by saw dust.

In the accompanying drawings, Figure 1, is a perspective view of the feed mechanism. Fig. 2, is a section at *x, x*, Fig. 1. Fig. 3, is a perspective view of head block and accessories. Fig. 4, is a section of the same at *y, y*, Fig. 3.

*A*, is a bed or frame. The arbor *C*, carries a driving pulley *E*, a pulley *u*, and a suit of differential pulleys *F*.

*M*, is a portion of the carriage timbers.

The feeding and backing movements of the carriage are derived from the arbor *C*, as follows: *P*, *Q*, and *O*, are respectively a feed pinion, shaft and feed drum of usual construction.

A standard *S*, rising from the frame *A*, has projecting horizontally from it a stud shaft *T*, forming the axle of a rocking arm *U*.

*V*, is another standard which affords a journal bearing permitting the combined rotary and vibratory motion of a shaft *W*, the other end of said shaft being journaled in one end of the rocking arm *U*. The said shaft *W*, carries a small friction pulley *X*, and a suit of differential pulleys *Y*, corresponding with those on the arbor *C*. The other end of the rocking arm *U* carries a small friction pulley *Z*, which when depressed communicates motion from the friction pulley *u*, to the pulley *o*, but which at other times is perfectly quiescent.

*a*, *b*, *c*, *d*, constitute an arrangement of lever and toggle connected with the rocking

arm *U*, and enabling the operator to place it in either desired position.

In using this machine the feed motion is varied from one quarter inch to one and three quarters inches "cut" per revolution of saw, according to the kind of timber; these differences of speed are provided for by the differential pulleys aforesaid. The speed of gigging back is a constant quantity, greatly exceeding the highest speed of the feed. The use of the toggle movement of the idle pulley *z* and their accessories in this connection will appear in the sequel.

The setting mechanism is as follows:—*e*, are the head blocks, *f*, the knees, *g* are the ways which support the log and which also support and guide the knees. *h*, is a horizontal rack perforated (5) between its cogs for the escape of saw dust. Depending from the lower edge of the rack *h*, is a vertical rack *i*, communicating by suitable gearing *j*, *k*, with the long rack bar *l*, as described in our patent of 7th Dec'r 1858. The long rack bar *l*, is operated by a suitable lever *m*. Journaled within the knee and meshing in the rack *h*, is a spur wheel *q*. A small spur wheel *q'*, also journaled within the knees meshes in the wheel *q*. The shaft of the wheel *q*, has attached to its end outside the knee *f*, a ratchet wheel *r*, which is sometimes held fast and at other times rotated by the lever, *s*, and pawls *t*, as hereafter explained. *v*, is a pin which projecting from the knee limits the backward sweep of the lever *s*.

A friction pawl *p*, having a weighted arm *p'* forbids the slightest retrograde motion of the knee by holding the latter to the very spot at which it has been placed by the setting mechanism.

Saw dust is excluded from the setting mechanism of the knee partly by a screen *w* which covers over and shelters the gearing, partly by the relative position of the lower edge of the knee base, and the tops of the rack teeth enabling the former to sweep the latter and partly by the action of the pinion *q*, meshing in the interstices of the rack and forcing through whatever saw-dust may have collected.

Operation: The carriage being run back to a proper distance a log is placed upon the ways *g*, the knees are separately moved up to it by means of the levers *s*, and the

log is confined by dogs in the usual manner. The lever *a*, being then placed in the position shown in the drawings, the feed or forward motion of the carriage is communicated from the saw arbor, through the medium of the differential pulleys F, and Y, band 4, shaft W, pulley X, drum O, shaft Q, and pinion P, to the customary rack beneath the carriage M.

The cut being completed the lever *a*, is reversed so as to bring the idler *z* in contact with the pulley *u*, on the arbor and with the drum O, so as to impart (without concussion) a prompt, positive and rapid reverse or 5 gigning back motion to the carriage until the log clears the saw, when the lever is suddenly placed in its former position and the opposing friction of the forward motion serves first to check and arrest the back 10 stroke of the carriage and then to impart the forward or feed motion. At the instant that the backward motion of the carriage has brought the log clear of the saw, both ends of the log are set simultaneously toward the 15 saw by a quick movement of the lever *m*, to the right and back again. The right movement of the lever *m*, operating through the gearing *l*, *k*, *j*, *i*, *h*, *q*, *q'*, *r*, results simply in a retrograde movement of the ratchet wheel 20 *r* but by the reverse or left movement of the lever *m*, the rotation of the pinions *q* *q'* being arrested by the now locked ratchet movement in consequence of the opposition of the pin *v*, the said pinion becomes immovable as 25 respects the knee which therefore moves forward with the transverse rack *h*, and the same action taking place in each block a simultaneous and equal setting of the two knees is the result.

The weighted cam headed lever or friction pawl *p* *p'*, is employed to retain the knees in the position in which they may be placed, and for this purpose operates with greater 30 certainty and accuracy than the customary devices of pawls and ratchet. Either knee may be set separately by means of its lever *s*, but the setting of the tail knee alone is most conveniently effected by means of the lever *m*, the pawls *t* of the head knee having 35 been previously thrown back.

In practice we extend the feed reverse shaft *a'*, to the outside of the frame so as to enable both the setting up lever *m*, and the feed reverse lever *a*, to be conveniently manipulated by the sawyer from one spot.

By using a ratchet wheel of larger diameter in reverse position on the shaft of the pinion *q*, the intermediate pinion *q'*, may be dispensed with or the ratchet wheel itself 40 may be dispensed with by adapting the pawl to mesh with either pinion but practical experience leads us to prefer the arrangement here shown.

The differential pulleys F, and Y, are employed to vary the rate of feed in accordance 65 with the character of the timber to be sawed but in order to save time and equalize power the log should be run back with great and uniform rapidity whatever be the rate of feed and this object has been realized, in the 70 use of these machines, more perfectly than we believe possible under any known plan.

A friction pulley communicating motion directly from the arbor to the feed drum is believed to form the best means of imparting 75 the rapid motion required in gigning back, being free on one hand from the concussion incident to the use of a clutch, and on the other hand avoiding the uncertainty of action inseparable from belt motion. The 80 great velocity, and consequent wear, and necessity for lubrication, of the backing mechanism, also makes it desirable it should be in motion only when required for active service, and with this object the friction pulley Z, is quiescent when not in contact with 85 the arbor.

Prompt and speedy application and effective pressure of the idler are secured by the adaptation of the toggle movement by 90 which a simple motion of a lever within compact dimensions is converted into a movement of the idler at first rapid and then forcible.

We are aware that the carriages of saw-mills have been fed and backed by the alternate impact of continuously revolving friction pulleys operating in different directions upon the feed drum but we are not aware that such has ever been effected within the 100 limits of a "portable" mill, by a backing pulley which remains at rest during the feed and requires for its operation no belted or like slack or tardy connection with the arbor.

We are also aware that for the speedy initiation of a powerful pressure the "toggle" 105 is a common expedient and therefore make no claim to such irrespective of the herein described specific application and adaptation of it; nor do we desire to limit ourselves 110 to a toggle, it being obvious that a cam or other customary equivalent would perform the same office in kind if not in degree.

We are also aware that attempts have been made to use friction cams or pawls as 115 means of communicating the setting movement to the knee, but have been inoperative because an uncertain amount of "slip" occurs that is fatal to the accuracy, also because the opposing inertia and friction of 120 heavy logs have necessitated so forcible a grip by the pawl as to bruise its periphery and to "peen" the surface against which it worked. But we are not aware that such a pawl has ever been used in this connection 125 as a simply detaining appliance so as to co-

operate with the resistance of the log. The pawl also acts to overcome any tendency of the log to roll or press back and to prevent the knee receding a short distance by reason  
 5 of the backward motion of the log should the dogs get loose even when the log has no tendency to pass back.

We claim as new and of our invention and desire to secure by Letters Patent—

10 1. The idle friction pulley Z operating substantially in the manner set forth, in combination with the arbor and feed drum of a circular saw.

15 2. In the described connection with the transverse rack *h*, the gearing *q*, *q'*, ratchet wheel *r*, pawls *t*, lever *s*, and stop *v*, which operate by their rigidity in one direction to transmit a forward movement of the rack *h*,

to the knee, *f*, yet permitting the retraction of said rack *h*, as set forth. 20

3. The described arrangement and adaptation of the weighted eccentric friction pawl for the exact retention of the knee, to the place of setting as set forth.

4. The described arrangement and adap- 25 tation of the perforated rack *h*, pinions *q*, *q'*, knee *f*, and screen Y, for the exclusion of dust as explained.

In testimony of which invention, we here- unto set our hands.

SAMUEL R. SMITH.  
 PHILANDER P. LANE.

Witnesses:

GEO. H. KNIGHT,  
 FRANCIS MILLWARD.