

(19)



(11) Publication number:

SG 188874 A1

(43) Publication date:

30.04.2013

(51) Int. Cl:

;

(12)

Patent Application

(21) Application number: **2013017355**

(71) Applicant:

**MOHAMED, ZAHROOF 16122
CROOKED LAKE WAY N, CYPRESS, TX
77433 TX US US**

(22) Date of filing: **18.11.2010**

(30) Priority: **US 61/262,248 18.11.2009**

(72) Inventor:

**MOHAMED, ZAHROOF 16122
CROOKED LAKE WAY N, CYPRESS, TX
77433 TX US**

(54) **Title:**

**SYSTEMS AND METHODS FOR A REED VALVE MODULE
AND VALVE ASSEMBLY**

(57) **Abstract:**

5 ABSTRACT SYSTEMS AND METHODS FOR A REED VALVE MODULE AND VALVE ASSEMBLY Reed valve modules and corresponding reed valve assemblies are disclosed. In one embodiment, the reed valve module includes a body having a single or a plurality of sealing faces, 10 a seat and flow passages from the seat to the sealing face(s). The reed valve module also includes one or a plurality of petals. In some embodiments, the module further includes a petal guard. Novel reed valve assemblies are disclosed incorporating the reed valve modules. One embodiment of the reed valve assembly includes a seat with a plurality of fluid conduits, a retainer plate with a plurality of fluid conduits and a means for receiving recesses between the seat plate and retainer 15 plate. Other devices, systems, and methods related to reed valve modules and valve assemblies are also disclosed. Fig. 7

SYSTEMS AND METHODS FOR A REED VALVE MODULE AND VALVE ASSEMBLY

Reed valve modules and corresponding reed valve assemblies are disclosed. In one embodiment, the reed valve module includes a body having a single or a plurality of sealing faces, a seat and flow passages from the seat to the sealing face(s). The reed valve module also includes one or a plurality of petals. In some embodiments, the module further includes a petal guard. Novel reed valve assemblies are disclosed incorporating the reed valve modules. One embodiment of the reed valve assembly includes a seat with a plurality of fluid conduits, a retainer plate with a plurality of fluid conduits and a means for receiving recesses between the seat plate and retainer plate. Other devices, systems, and methods related to reed valve modules and valve assemblies are also disclosed.

Fig. 7

5 **SYSTEMS AND METHODS FOR A REED VALVE MODULE AND VALVE ASSEMBLY**

RELATED APPLICATIONS

[0001] This application claims priority to US Provisional Patent Application 61/262,248, entitled "Reed Valve Module and Valve Assembly" filed November 18, 2009, which is incorporated by reference in its entirety.

10 **FIELD OF THE INVENTION**

[0002] The present invention relates generally to valve assemblies. More particularly, the present invention relates to a novel reed valve module that can be used in a valve assembly in various flow control systems, including compression systems, and systems and methods thereof.

BACKGROUND

15 **[0003]** As will be appreciated, fluids, such as natural gas, hydrogen, process gases, refrigerants and air, have a wide array of uses in industrial and commercial applications. For instance, natural gas may be used to provide power to a range of vehicles, to heat homes during winter, and to operate various consumer appliances, such as ovens or clothes dryers. Further, natural gas may be used to generate electricity for distribution over a power grid. Different process gases and air may
20 be used in the manufacture of an array of products and materials, including glass, steel, and plastics, for example.

[0004] To meet the demand for natural gas, companies may spend a significant amount of time and resources searching for, extracting, and transporting natural gas. Hydrogen may be produced centrally and distributed through pipelines. In process plants different gases or liquids are
25 transported through passages to the point where it may be required. In most large factories air under pressure is made available at different points through a network of pipes. As may also be appreciated, transportation of such gases or liquids, such as through a pipeline from one point to another, is often facilitated by compression of the gas or liquid via a compressor or pump.

[0005] One common type of compressor for such applications is the reciprocating compressor.
30 Such reciprocating compressors are positive-displacement devices that generally utilize a

5 crankshaft that is coupled to pistons, via connecting rods and crossheads, to reciprocally drive the pistons and compress a fluid within attached compression cylinders. As may be appreciated by one skilled in the art, gas is generally introduced into compression chambers of the cylinders through one or more inlet or suction valve assemblies and, following compression, the fluid generally exits the cylinders via one or more outlet or discharge valve assemblies.

10 **[0006]** The type of valve assemblies commonly used in compressors includes poppet valves, plate valves, ring valves, channel valves and reed valves. In the current art, poppet valve, plate valve, ring valve and channel valve assemblies, all traditionally include a single or a set of sealing elements disposed between a seat plate and a guard plate. Current reed valve assemblies used in
15 attached to the seat plate by a fastening means such as screws.

[0007] As many compressors routinely operate at hundreds or thousands of rotations per minute (rpm), the sealing elements also open and close at a similarly high rate. Due to this rapid cycling, the seat plate, the guard, and/or the sealing elements will often wear over time, leading to valve failure if left unchecked. To avoid such failure, in a preventive maintenance program, the
20 valves are periodically removed from the compressor and refurbished. Sometimes failure cannot be avoided. However, the valves can typically be repaired and reused, especially the expensive seat and guard. This is typically accomplished through replacement of the sealing elements, machining/refinishing or replacement of the seat and/or guard, or the like. Of course, such maintenance is often time-consuming and/or costly.

25 **[0008]** In existing art, in the reed valve assembly, the petals and guards are attached to the seat/body/cage by individual fastening means. It is possible for these fastening means to loosen during operation, eventually coming off. Petals can fail in fatigue and pieces may break off. These loose pieces can fall into the cylinder and causing extensive damage to the compressor or engine piston/cylinder.

30 **[0009]** The cost of the power required to compress the gas is the major operational expense incurred by a company engaged in this business. The efficiency of the compressor determines the power required to operate it; the higher the efficiency, the lower the costs. Valve losses are a

5 major source of loss in efficiency in compressors and can contribute from 5 to 20% of the overall operating costs. In existing reed valve, poppet valve, plate valve, ring valve and channel valve assemblies used in the compression process, the gas has to make two right angle turns to get by the sealing element while passing through the valve. The greater the turning angle, the greater the resistance to the flow through the compressor; directly affecting the efficiency adversely.

10 **[0010]** The amount of time required to install a valve successfully, determines the amount of time that a machine is down and, in turn, the amount of money that is lost due the machine being down. For valves installed in the field, it is very difficult to check the quality of the assembled valve as this depends on the tolerance of all the parts and how it is assembled. A minor problem in
15 a seat or guard can mean that none of the sealing elements seal properly – and this can only be found after the entire valve has been assembled and installed.

SUMMARY

[0011] Certain aspects commensurate in scope with the originally claimed invention are set forth below. It should be understood that these aspects are presented merely to provide the reader with a brief summary of certain forms the invention might take and that these aspects are not
20 intended to limit the scope of the invention. Indeed, the invention may encompass a variety of aspects that may not be set forth below. Embodiments of the present invention generally relate to a novel reed valve module and its valve assembly. In some exemplary embodiments, a reed valve module includes a body including a seating surface, one or more sealing faces, and one or more fluid conduits leading from the seating surface to the sealing faces. The reed valve module also
25 includes a single or plurality of reed petals positioned over the sealing face of the module body and one or more walls opposite the body from the single or plurality of reed petals. In another embodiment, a reed valve module comprises a modular valve body having a plurality of faces and one or more ports and one or more reed petals each sized to substantially cover one or more of the one or more ports of the modular valve body. The reed valve module also includes a modular
30 housing sized for a frictional fit when disposed within a receiving recess with the modular valve body and the one or more reed petals within and secured by a seat plate. In yet another embodiment, a reed valve module comprises a modular valve body having a plurality of faces and one or more ports and one or more reed petals each sized to substantially cover one or more of the

5 one or more ports of the modular valve body. The modular valve body and the one or more reed petals are collectively sized for a frictional fit when disposed within a receiving recess with the modular valve body and the one or more reed petals within.

[0012] In another embodiment, a modular reed valve assembly comprises a seat plate including one or more fluid conduits and one or more receiving recesses, each proximate a
10 respective fluid conduit of the one or more fluid conduits in the seat plate. The modular reed valve assembly also includes a retainer plate including one or more fluid conduits and one or more reed valve modules, sized to fit either individually or collectively within one of the one or more receiving recesses. In yet a further embodiment, a modular reed valve assembly comprises a seat
15 plate including one or more fluid conduits and one or more receiving recesses, each proximate a respective fluid conduit of the one or more fluid conduits in the seat plate. Each of the one or more receiving recesses includes a groove and one or more reed valve modules. Each reed valve module comprises a modular housing including a protrusion sized to fit into the groove to secure the reed valve module when the modular housing is inserted into a respective one of the one or more receiving recesses.

20 **[0013]** In another embodiment, a method of assembling a reed valve module comprises the following: obtaining a modular reed valve body including a seating surface, one or more sealing faces, and one or more fluid conduits leading from the seating surface to the sealing faces; obtaining at least one reed petal, sized for one or more of the one or more sealing faces; obtaining a modular housing; placing the at least one reed petal over the one or more of the one or more
25 sealing faces; and placing the modular reed valve body and the at least one reed petal into the modular housing. In a further embodiment, a method of assembling a reed valve assembly comprises the following: obtaining one or more reed valve modules; obtaining a seat plate including one or more fluid conduits and one or more receiving recesses, each of the one or more receiving recesses proximate a respective fluid conduit of the one or more fluid conduits in the
30 seat plate; and inserting one of the one or more reed valve modules into a respective receiving recess of the one or more receiving recesses. Another aspect of the present invention is a compressor comprised of a frame, a plurality of mechanical components disposed with the frame that compress a working fluid, and at least one modular reed valve assembly coupled to the frame

5 and the plurality of mechanical components to control the flow of fluid through at least one modular reed valve.

[0014] Various refinements of the features noted above may exist in relation to various aspects of the present invention. Further features may also be incorporated in these various aspects as well. These refinements and additional features may exist individually or in any combination.

10 For instance, various features discussed below in relation to one or more of the illustrated embodiments may be incorporated into any of the above-described aspects of the present invention alone or in any combination. Again, the brief summary presented above is intended only to familiarize the reader with certain aspects and contexts of the present invention without limitation to the claimed subject matter.

15 BRIEF DESCRIPTION OF THE DRAWINGS

[0015] These and other features, aspects, and advantages of the present invention will become better understood when the following detailed description is read with reference to the accompanying drawings in which like characters represent like parts throughout the drawings, wherein:

20 FIG. 1 is a perspective view of a reciprocating compressor including an exemplary modular reed valve assembly in accordance with one embodiment of the present invention;

FIG. 2 is an axial cross-sectional view of the exemplary compressor of FIG. 1, illustrating internal components of the compressor in accordance with one embodiment of the present invention;

25 FIG. 3 is a view of the exemplary modular reed valve assembly with a partial cross section, according to one embodiment of the present invention;

FIG. 4 is an exploded view of the modular reed valve of FIG. 3 illustrating certain components of the modular reed valve assembly, in accordance with one embodiment of the present invention;

FIG. 5 is an exploded view of a modular reed valve assembly having modular reed valves of varying sizes in accordance with one embodiment of the present invention;

5 FIG.6 is a perspective view of an exemplary reed valve sub-assembly module in accordance with one embodiment of the current invention;

FIG. 7 is an exploded view of the reed valve module of FIG. 6 showing certain components of the sub-assembly in accordance with one embodiment of the present invention;

10 FIG. 8 is a cross-sectional view of the exemplary reed valve module of FIG. 6, depicting the petals in a closed position and in accordance with one embodiment of the present invention;

FIG. 9 is a cross-sectional view of a modular reed valve composed of inner petals in addition to outer petals in accordance with one embodiment of the present invention;

FIG. 10 is a perspective view of an exemplary modular reed valve assembly with a partial cross section in accordance with one embodiment of the present invention;

15 FIG. 11 is a perspective view, with a partial cross section, of a device using modular reed valves, where a portion of the reed valve assembly is integrated into the structure of the device itself;

FIG. 12 is an exploded view, with partial cross sections, of the device illustrated in FIG 11 showing the certain components of the device including the reed valve modules;

20 FIG. 13 is an exploded view of an exemplary modular reed valve with an internal securing mechanism in accordance with one embodiment of the present invention;

FIG. 14 is top view of a single valve petal in an unbent state that covers multiple sealing faces in accordance with embodiments of the present invention, such as shown in FIG. 13; and

25 FIG. 15 is a partial cut-away view of an exemplary modular reed valve assembly showing the internal securing mechanism from FIG. 13 in accordance with one embodiment of the present invention, eliminating the retainer plate and fasteners.

DETAILED DESCRIPTION

[0016] One or more specific embodiments of the present invention will be described below. In an effort to provide a concise description of these embodiments, all features of an actual

5 implementation may not be described in the specification. It should be appreciated that in the development of any such actual implementation, as in any engineering or design project, numerous implementation-specific decisions must be made to achieve the developers' specific goals, such as compliance with system-related and business-related constraints, which may vary from one implementation to another. Moreover, it should be appreciated that such a development
10 effort might be complex and time consuming, but would nevertheless be a routine undertaking of design, fabrication, and manufacture for those of ordinary skill having the benefit of this disclosure.

[0017] When introducing elements of various embodiments of the present invention, the articles "a," "an," "the," and "said" are intended to mean that there are one or more of the
15 elements. The terms "comprising," "including," and "having" are intended to be inclusive and mean that there may be additional elements other than the listed elements. Moreover, the use of "top," "bottom," "above," "below," and variations of these terms is made for convenience, but does not require any particular orientation of the components.

[0018] Turning now to the figures, an exemplary compressor 10 is provided in FIG. 1. In the
20 presently illustrated embodiment, the compressor 10 includes a pair of compression cylinders 12 coupled to a frame 14. As discussed in greater detail below, a variety of internal components may be disposed within the cylinders 12 and the frame 14 to enable compression of fluids within the cylinders 12. In one embodiment, the compressor 10 may be utilized to compress natural gas. However, in other embodiments, the compressor 10 may be configured and/or utilized to compress
25 other fluids. A mechanical power source or driver 16, such as an engine or an electric motor, may be coupled to the compressor 10 to provide mechanical power to the various internal components and to enable compression of the fluid within the cylinders 12. To facilitate access to such internal components, as may be desired for diagnostic or maintenance purposes, openings in the frame 14 may be provided and selectively accessed via removable covers disposed over the openings.

30 **[0019]** Further, the exemplary cylinders 12 include capped recesses 18 configured to receive valve assemblies, such as modular reed valve assembly 20 in accordance with the embodiment of the present invention. While only a single modular reed valve assembly 20 is illustrated, it will be appreciated that, in various embodiments, additional modular reed valve assemblies 20 are

5 included within some or all of the other capped recesses 18. It will also be appreciated that the
cylinders 12 may include internal fluid conduits between the recesses 18 and the modular reed
valve assemblies 20 to facilitate flow of a fluid into and out of the cylinders 12 through such
modular reed valve assemblies 20. Additionally, various installation components, such as cages or
fasteners (not shown here), may be employed to facilitate mounting of the modular reed valve
10 assemblies 20 within the recesses 18.

[0020] Although the exemplary compressor 10 is illustrated as a two-throw reciprocating
compressor, other compressor configurations may also employ and benefit from the presently
disclosed techniques. For instance, in other embodiments, the compressor 10 may include a
different number of cylinder throws, such as a four-throw compressor, a six-throw compressor, a
15 couple-free reciprocating compressor, or the like. Further, other variations are also envisaged,
including variations in the length of stroke, the operating speed, and the size, to name but a few.
Further, the machine in which the valve is employed may be of a different type such as a screw
compressor, scroll compressor, refrigeration compressor, a centrifugal compressor, a chiller, a
process flow system etc.

20 **[0021]** A cross-sectional view of the exemplary compressor 10 is provided in FIG. 2, which
illustrates a number of exemplary internal components of the compressor of FIG. 1. In the
presently illustrated embodiment, the frame 14 of the exemplary compressor 10 includes a hollow
central body or housing 22 that generally defines an interior volume 24 in which various internal
components may be received, such as a crankshaft 26. In one embodiment, the central body 22
25 may have a generally curved or cylindrical shape. It should be noted, however, that the central
body 22 may have other shapes or configurations in full accordance with the present techniques.

[0022] In operation, the driver 16 rotates the crankshaft 26 supported within the interior
volume 24 of the frame 14. In one embodiment, the crankshaft 26 is coupled to crossheads 30 via
connecting rods 28 and pins 32. The crossheads 30 are disposed within crosshead guides 34,
30 which generally extend from the central body 22 and facilitate connection of the cylinders 12 to
the compressor 10. In one embodiment, the compressor 10 includes two crosshead guides 34 that
extend generally perpendicularly from opposite sides of the central body 22, although other
configurations are also envisaged. As may be appreciated, the rotational motion of the crankshaft

5 26 is translated via the connecting rods 28 to reciprocal linear motion of the crossheads 30 within the crosshead guides 34.

[0023] As noted above, the cylinders 12 are configured to receive a fluid for compression. The crossheads 30 are coupled to pistons 36 disposed within the cylinders 12, and the reciprocating motion of the crossheads allows compression of fluid within the cylinders 12 via the
10 pistons 36. Particularly, as a piston 36 is driven forward (i.e., outwardly from central body 22) into a cylinder 12, the piston 36 forces fluid within the cylinder into a smaller volume, thereby increasing the pressure of the fluid. A discharge valve, such as modular reed valve assembly 20, may then open to allow the pressurized or compressed fluid to exit the cylinder 12. The piston 36 may then stroke backward, and additional fluid may enter the cylinder 12 through an inlet valve,
15 which may also comprise a modular reed valve assembly 20, for compression in the same manner described above. Further, as will be appreciated, the cylinders 12 can be configured to facilitate fluid compression on both the forward and the backward strokes of the piston 36. For instance, as the piston 36 moves forward in the manner discussed above to compress fluid on one side of the piston, additional fluid may be introduced into the cylinder on the opposite side of the piston.
20 Such fluid would then be compressed on the backward stroke of the piston 36.

[0024] Exemplary modular reed valve assemblies 20 in accordance with certain embodiments of the present invention are depicted in FIGS. 3-5, 10-12, and 15. Generally these embodiments represent various modular reed valve assembly 20 configured as a discharge valve, while FIG. 10 represents a suction valve. As shown in FIGS. 3-4, the exemplary modular reed valve assembly 20
25 includes a seat plate 42 and a retainer plate 44. The seat and retainer plates, 42 and 44, may be coupled to one another via one or more studs 48 and nuts 50 or using some other suitable fastening means. It should be noted that in this embodiment the stud 48 and nut 50 are centrally located. In other embodiments, screws or stud/nuts may be employed along the periphery of the valve seat (in the case of a discharge valve) or the valve retainer (in the case of an inlet valve) such that they are
30 captured by a cage used to locate the modular reed valve assemblies 20 in the recesses 18.

[0025] In this embodiment, the valve assembly 20 includes a seat plate 42 and a retainer plate 44 having a number of fluid passageways or ports 320 and 340, respectively, that allow a fluid, such as natural gas, to flow through the modular reed valve assembly 20. In this embodiment of

5 the present invention, the seat plate 42 has a receiving cavity 330, downstream of each of the fluid ports 320, that locates and firmly secures a reed valve module (or modular reed valve) 46 within the modular reed valve assembly 20. In other embodiments of the invention, the receiving cavity 330 may be provided in the retainer plate 44, or distributed partially between the seat plate 42 and retainer plate 44, or there could be a separate plate, receiving cavity plate (see FIG. 10),
10 sandwiched between the seat plate 42 and retainer plate 44 that has receiving cavities 330 in its entirety or partially. As discussed in greater detail below, the exemplary modular reed valve assembly 20 also includes one or a plurality of reed valve modules 46, located in the receiving cavity 330 and secured by the seat plate 42 and retainer plate 44.

[0026] In some embodiments of the present invention, such as the embodiment illustrated in
15 FIGS. 3 – 5, each flow port 320 leads into a single receiving cavity 330 that leads to a single exit flow port 340. The receiving cavity 330 is configured to locate only a single reed valve module 46 therein. As shown, in other embodiments, however, there may be one or more flow ports 320 that lead into a receiving cavity 330 that in turn leads into one or more exit flow ports 340. The receiving cavity 330 may in those embodiments receive multiple reed valve modules 46. Further,
20 while certain embodiments of the modular reed valve assembly 20 include a plurality of reed valve modules 46, it should be noted that other embodiments may instead include only one reed valve module 46 in full accordance with the present disclosure. It should be noted that in other embodiments of the present invention, the seat plate 42, or retainer plate 44 may be integrated into the frame 14 of the machine in which the valve assembly is employed.

25 **[0027]** The reed valve modules 46 selectively control the flow of a fluid through the fluid port 320, through the reed valve module 46 and out through the port 340. The seat plate 42 and retainer plate 44 secure the reed valve modules 46 between them. The seat plate 42 may be formed from metal, fiber reinforced composite or some other suitable high-strength material. The retainer plate 44 and the receiving cavity plate have lower strength requirements, but may also be made
30 from metal, fiber reinforced composite or plastic. It should be noted that in other embodiments, there may be provisions on the modular reed valve assembly, 20, to accommodate an unloading device, a clearance volume device or other devices that are located on valves in current practice.

5 **[0028]** An exemplary valve assembly, 20A, in accordance with certain embodiments of the present invention is depicted in FIG. 5. The valve assembly includes a seat plate 42A and a retainer plate 44A. The seat and retainer plates, 42A and 44A, are attached to one another by means of four cap screws 49 in this embodiment. Also in this embodiment, there are six modules in total, two modules 46 of one size, two modules 510 of another size, and the last two modules
10 520, of a third size. In other embodiments, there may be several different sizes of modules, they may be distributed asymmetrically in the valve and they need not be in pairs.

[0029] Exemplary reed valve modules 46 in accordance with certain embodiments of the present invention are depicted in FIGS. 6–8. FIG 6 is a perspective view of the reed valve module 46. In certain embodiments of the current invention, such as that illustrated in the FIGS. 6–8, the
15 reed valve module 46, includes a body 610, one or more petals 620, and may include a petal guard (or stopper) 630. In certain embodiments, the body 610 and/or guard 630 are made of plastic, with or without carbon or glass fibers, and is formed through a suitable manufacturing process, such as injection molding, compression molding, machining or another suitable process. The amount of fiber contained in the plastic is determined based on obtaining an optimum amount of strength for the valve body and impact absorption for the petals to increase the reliability of the valve. It
20 should be noted, however, that certain applications may dictate that the body 610, and/or guard 630, be formed from metal or some other suitable high strength material through a suitable manufacturing process such as metal injection molding, casting, powder metallurgy or machining. When the body 610 is made of metal and the petals 620 are of metal, plastic inserts (not shown)
25 may be used in the body 610 for the sealing face in order to soften the impact force. In other embodiments of the present invention, the body 610 and/or guard 630 may be made of metal with a relatively thick coating of plastic or elastomer. It is not necessary that the body 610 and the guard 630 be made of the same material. In one embodiment of the present invention, the reed valve petals 620, are made of stainless steel made from precision sheet strips using photo-chemical
30 milling, stamping, water jet cutting, laser cutting, wire EDM, or other suitable manufacturing process. However, in other embodiments, the petals 620 may be made of steel, fiber reinforced composite or some other high fatigue strength, flexible material suitable for the application.

5 **[0030]** The body 610 includes a seat 640 that abuts against the seat plate 42 (not shown here) when the reed valve module 46 is assembled into the modular reed valve assembly 20. The body 610 may be divided into flow passages 650, by means of ribs 660 and 670 that also reinforce the body 610. The transverse ribs 660 also act to support the petals 620 when they are in the closed position and subject to high differential pressure. In certain embodiments of the present invention,
10 there may be passages that are present in the ribs 660 and 670 that connect one or more flow passages. The flow passages 650 lead from the valve seat port 320 for this reed valve module 46 to one or more body seal faces 710. The body seal faces 710 are formed to be flat and at a small angle from the vertical so that the fluid that passes through the reed valve module 46 does not make any large angle turns in passing through it. In certain embodiments of the present invention,
15 such as illustrated in FIGS. 6–8, there are two body seal faces 710, at an angle to the vertical for each body 610. However, in other embodiments there may be only one seal face 710 formed at an angle to the vertical. In other embodiments, there may be several faces as illustrated in FIG. 13. In certain other embodiments, the seal faces 710 may be vertical.

[0031] Corresponding to each body seal face 710, there are one or more valve petals 620 that
20 lie flat against the body seal face 710 in the reed valve module 46 in the assembled state, essentially sealing it. Each petal 620 has an initial portion that is used to secure it in the valve module and a latter portion that seals the body 610 when the pressure is greater on the exit port 340 and deflects to open up the body seal face 710 when the pressure is greater on the inlet fluid port 320. On the deflection side of the petals 620, there may be slits that divide the petals into
25 separate sealing elements and allow it to independently seal different flow passages 650 in the body 610. On the secured portion of the petals 620, there may be one or more cut outs 740 that engage with protrusions 760 on the guard 630 and corresponding slot 720 in the body 610.

[0032] The petal guard 630 has an inside surface, the initial portion of which is contoured to capture the body 610 and petals 620 and the latter portion to provide a surface for the petal 620 to
30 impact against in its fully open state. Grooves 750 may be provided on the latter portion of the guard 630 inside surface to reduce the sticktion effects found in valves where they may be liquids present. In certain embodiments of this invention, as shown in the illustrations in FIGS. 6-9, the guards may have a plurality of trap members 770 at the bottom. These trap members 770

5 preferably prevent any large pieces that may break off from the reed valve module 46, in particular pieces of the petal 620, from escaping the reed valve module 46 and in particular, migrating to the cylinder 12 and causing damage. The bottom 780 of the petal guard 630 is designed to be larger than the flow port 340 in the retainer plate 44 so that the bottom 780 abuts against the retainer plate 44 and holds the reed valve module 46 within the modular reed valve assembly 20. In other
10 embodiments of the petal guard 630, there may be no trap members 770. In certain embodiments of the present invention, the petal guard 630 may have side walls connecting the contoured walls of the body seal faces 710. In other embodiments, the petal guard 630 may have neither trap members 770 nor side walls. In this case the petal guard 630 is held in position when the reed valve module 46 is placed in the receiving cavity 330. In certain embodiments of the present
15 invention, instead of the bottom of the guard 780 being used to secure the reed valve module 46 within the modular reed valve assembly 20, a lip 530 (shown in FIG. 5) may be provided on the outer wall of the guard 630 and/or the body 610 (not shown); the receiving cavity 330 may be shaped so that this lip 530 engages with a step in the cavity 330 securing the reed valve module 46 in the modular reed valve assembly 20. Other or additional attachment mechanisms, however,
20 could be provided in full accordance with the present techniques.

[0033] The cutouts 740, protrusions 760 and slots 720 locate the petal 630 against the seal face and additionally, in conjunction with the friction force, act as a positive restraint preventing the petal 630 from dropping. In other embodiments of the present invention, the protrusion 760 may be on the body 610 and the corresponding slot 720 on the guard 630. In one embodiment of the
25 present invention, as illustrated in the FIGS. 6 – 8, for body seal faces 710 that are at an angle, the petals 630, are wedged between the body 610, and the petal guard 630 in the reed valve module 46. In certain other embodiments, where the seal face 710 is vertical, the petals 620 are held in place in the reed valve module 46 by means of the clamping force produced when the module is pressed into the receiving cavity 330. This clamping force is induced by an interference fit
30 between the reed valve module 46 and the walls of the receiving cavity 330 or by suitably shaping the reed valve module 46 and recess cavity 330 walls to provide the necessary clamping force. In certain other embodiments, the petal guard 630 is eliminated from the reed valve module 46. Instead, the inner walls of the recess 330 are contoured similar to the inner walls of the petal guard 630 so that it provides the same function (see FIGS. 11-12).

5 **[0034]** Advantageously, in the embodiment illustrated in FIGS 3 – 8, the modular reed valve assembly 20 is configured to facilitate efficient servicing or repair. Notably, all the wear is preferably contained within the reed valve module 46 that houses: the petals 620, which may wear due to fatigue and impact, the body 610, the seal face 710, which is subject to repeated impacts from the petal 620, and the guard 630, which is also subject to impacts from the petal 620 during
10 opening of the valve. The preferred method of servicing of the modular reed valve assembly 20 is to simply replace all the reed valve modules 46 at the pre-established maintenance time. There is no machining required for the valve seat plate 42 or valve retainer plate 44 as these components should not wear, unlike in the case with existing plate, poppet, channel and reed valves. The present invention allows the modules to come pre-assembled and tested for quality direct from the
15 factory and thus eliminates the need for complex testing equipment to test the assembled modular reed valve assembly 20 after repair. The refurbishing and repair of these modular reed valves assemblies 20 can thus be done in the field, substantially reducing the cost of repair and the down time of the equipment. The modular design substantially eliminates the need to replace the expensive valve seat plate 42 and valve retainer plate 44, making these valves very cost effective
20 over the life of the machine. In existing designs for poppet, plate, ring, channel and reed valves, the seat plate 42 and retainer plate 44 or guard typically need to be replaced after it has been refurbished a couple of times. In a non-preferred embodiment, it is also possible to replace components of the reed valve module 46 in the field, specifically the petals 620, the guard 630 or the body 610.

25 **[0035]** The working of the valve is made clear by observing the FIG. 3 and the cross-section through a module FIG. 8. When the pressure of the fluid above the seat plate 42 in the modular reed valve assembly 20 is higher than the pressure below the retainer plate 44, the differential pressure across the petal 620 in the reed valve module 46 causes the petal 620 to deflect and sets the reed valve module 46 and therefore the modular reed valve assembly 20 in an open state. Fluid
30 moves from above the seat plate 42, through the fluid ports 320 through the module body 610 and out through the trap members 770 of the guard 630, and finally through the fluid ports 340 in the retainer plate 44 into the lower pressure zone. When the pressure on either side of the modular reed valve assembly 20 equalizes, the petals 620 close, effectively sealing off the module body 610. In the closed position, the modular reed valve assembly 20 does not allow flow of fluid from

5 below the retainer plate 44 to above the seat plate 42, even when the pressure below the retainer plate 44 is substantially higher than the pressure above the seat plate 42.

[0036] An exemplary reed valve module in accordance with certain embodiments of the present invention is depicted in FIG. 9. This embodiment of the reed valve module 46B includes a set of inner petals 910 in addition to the outer petals 620. In the embodiment illustrated in FIG. 9,
10 the inner petals 910 are pressed against the seal face 710 by the outer petals 620. In this embodiment of the current invention, only the outer petals are clamped to the body 610 by the guard 630.

[0037] An exemplary modular reed valve assembly 20B in accordance with certain embodiments of the present invention is depicted in FIG. 10. In this embodiment of the present
15 invention, the receiving cavities 330 are located in a separate plate 43 that is sandwiched between the seat plate 42 and the retainer plate 44. Other features of FIG. 10 may be found in the descriptions of FIGS. 3–8.

[0038] A perspective view of a device with a partial cross section is shown in FIG. 11 and its exploded view is illustrated in FIG. 12. The device 1100 incorporates a modular reed valve
20 assembly 20 in accordance with one embodiment of the present invention. The device 1100, that could represent a compressor cylinder, engine or a process flow pipe, for instance, consists of a frame 60 that is divided into two volume regions 62 and 64. A modular reed valve assembly 20 is incorporated in the device that allows the fluid to flow from region 62 to 64, but not the other way. In these embodiments of the present invention, the reed valve modules 46C, do not have petal
25 guards 630 as part of the reed valve module 46C. The reed valve modules 46C are located in receiving cavities 330 that are an integral part of the frame 60. In effect, in this embodiment, the retainer plate 44 carries the receiving cavities 330 and the retaining plate 44 is integrated into the frame 60. Moreover, the inner surface of the receiving cavities 330 is contoured to serve the same function as the inner surface of the petal guard 630 shown in FIGS. 6 – 9. That is, these
30 embodiments clamp the petals 620 to the body 610 and prevent the body 610 from falling out of the cavity 330, and they limit the excursion of the petals 620 when it opens. The reed valve module 46C is secured in the receiving cavity 1210 by means of a seat plate 42 by means of a fastening means such as screws 49.

5 **[0039]** An exemplary reed valve module sub-assembly 46D, in accordance with certain
embodiments of the present invention is depicted in Fig. 13, in the exploded state. The valve body,
610C, has a seat face, 640C and six sealing faces, 710C, in this embodiment. The reed valve
module 46D may consist of one or more valve petals 620C that seal the individual sealing faces,
710C. In this embodiment, a single petal, 620C, depicted in the unbent state in FIG. 14, and
10 formed into a suitable shape in the final state, covers all sealing faces, 710C, of the valve body,
610C, in the reed valve module sub-assembly 46D. The valve body 610C and petals 620C are
secured in the petal guard/housing, 630C, when the reed valve module sub-assembly, 46C, is
assembled into the modular reed valve assembly, 20D.

[0040] In FIG. 13, one embodiment of the petal guard/housing, 630C, is of a snap fit design so
15 as to eliminate the retainer (screw/nut, ect.) in the modular reed valve assembly 20D in which
these modules are assembled. The slits, 1310, and the protrusion, 680, enable the reed valve
module sub-assemblies 46D, to be assembled into the seat, 42D, of the valve assembly, 20D, in
FIG. 15, without the need of a retainer, stud(s) or nut(s).

[0041] An exemplary modular reed valve assembly 20D, in accordance with certain
20 embodiments of the present invention is depicted in FIG. 15. The retainer, stud(s) and nut(s) that
were shown in the other embodiments, 20 and 20B, have been eliminated by the use of a snap fit
reed valve module sub-assembly 46D, one embodiment of which, is shown in FIG. 13. Each of the
receiving cavities, 330C, in the seat, 42D, have a groove, 1510, cut into it to receive the
protrusions, 680, on the outside surface of the petal guards, 630C, in the snap-fit design reed valve
25 module sub-assemblies 46D.

[0042] Generally, speaking for most embodiments of the present invention, it will be
appreciated that during passage of the fluid through the modular reed valve assembly 20, the fluid
is travelling in essentially a straight path with very little losses due to turning of the fluid. This is
unlike the case in current designs of compressor plate, poppet, channel, ring and reed valves where
30 the fluid essentially has to make two right angle turns to go past the sealing element resulting in
large valve losses. Additionally, the compact design of the reed valve module 46 and the flow
characteristics of this design, allow a more effective coverage of an available valve area with fluid
flow area when utilizing the illustrated embodiments of this invention resulting in a more efficient

5 valve when compared to existing plate valves, ring valves, poppet valves, channel valves and reed valves.

[0043] Additionally, it will be appreciated that in the illustrated embodiments of the present invention, if a foreign body, such as rust, passes through the modular reed valve assembly 20, the damage is limited to one or two flow paths 650 within a single reed valve module 46 of the modular reed valve assembly 20. The flow path provided by each reed valve module 46 is independent of that of another reed valve module 46. Since a typical modular reed valve assembly 20, may consist of several reed valve modules 46, the modular reed valve assembly 20 may continue to operate effectively until a planned shutdown allows the repair of the affected reed valve module(s) 46 saving money for the operator. However, in the case of existing valve designs, such an incident would lead to a more urgent repair situation. In the case of plate valves that have only one sealing element the damage would require immediate shutdown and repair of the machine in which the valve is installed.

[0044] In one embodiment, the petal guards are composed of a plastic with a predetermined amount of fiber, 0-25%, to provide an optimum combination of strength for the operating conditions and the ability to absorb impacts and diffuse the energy of the petals. In one embodiment, the reed valve module body is composed of a plastic with a predetermined amount of fiber, 0-60%, to provide an optimum combination of strength for the body at operating conditions and an ability to absorb impacts of the single or plurality of reed petals. In another embodiment, the reed valve body is made of a metal, formed through a metal injection molding process. The petals may be made of fiber reinforced composites to improve reliability. The petal guards may be metal, formed through a metal injection molding process.

[0045] While the invention may be susceptible to various modifications and alternative forms, specific embodiments have been shown by way of example in the drawings and have been described in detail herein. However, it should be understood that the invention is not intended to be limited to the particular forms disclosed. Rather, the invention is to cover all modifications, equivalents, and alternatives falling within the scope of the invention as defined by the following appended claims.

5 CLAIMS:

1. A reed valve module, comprising:
a body including a seating surface, one or more sealing faces, and one or more fluid conduits
leading from the seating surface to the sealing faces;
a single or plurality of reed petals positioned over the sealing face of the module body; and
10 one or more walls opposite the body from the single or plurality of reed petals.
2. The reed valve module of claim 1, wherein the one or more sealing faces on the
module body are each at an angle substantially perpendicular to the seating surface so that the flow
of a fluid through the reed valve module experiences minimal turning.
15
3. The reed valve module of claim 1, wherein a cavity within the body is reinforced
by ribs that may also divide the cavity into separate independent flow passages.
4. The reed valve module of claim 1, wherein the cavity within the body is reinforced
20 by ribs, the end surfaces of which are flush with the sealing surface, the ribs providing
reinforcement to the module body and the end surfaces providing support to the single or plurality
of reed petals in a closed state.
5. The reed valve module of claim 1, wherein the one or more walls are contoured so
25 as to produce a clamping force on the single or plurality of reed petals when the reed valve module
is secured by a seat plate.
6. The reed valve module of claim 1, wherein each of the one or more walls act as a
petal guard, an inner surface of which reduces impact forces on one or more of the single or
30 plurality of petals when opening, and wherein an initial part is contoured to co-operate with the
body to clamp the single or plurality of reed petals against the one or more sealing faces of the
body.

5 7. The reed valve module of claim 6, wherein the petal guard has material removed from a lower portion of an inner surface in a predetermined way to prevent sticktion of any of the one or plurality of reed petals.

10 8. The reed valve module of claim 1, wherein the wall includes a protrusion sized to fit into a groove to secure the reed valve module when inserted into a respective receiving recess

 9. A reed valve assembly, comprising:
a seat plate including one or more fluid conduits;
one or more receiving recesses, each proximate a respective fluid conduit of the one or more fluid
15 conduits in the seat plate;
a retainer plate including one or more fluid conduits; and
one or more reed valve modules, sized to fit either individually or collectively within one of the one or more receiving recesses.

20 10. The reed valve assembly of claim 9, wherein each of the one or more reed valve modules is held pressed into one of the one or more receiving recesses by the seat plate and the retainer plate by a fastener.

 11. The reed valve assembly of claim 9, wherein the one or more receiving recesses are
25 located within the seat plate.

 12. The reed valve assembly of claim 9, wherein the one or more reed valve modules includes a petal, and wherein walls of the one or more receiving recesses include a contour that receives a top portion of the petal to secure the one or more reed valve modules in the one or more
30 receiving recesses.

 13. The reed valve assembly of claim 9, further comprising:
a separate receiving recess plate including the one or more receiving recesses, wherein the
 separate receiving recess plate is sandwiched between the seat plate and the retainer plate.

35

5 14. The reed valve assembly of claim 9, wherein the one or more reed valve modules
comprises a plurality of reed valve modules, wherein the plurality of reed valve modules include
one or more first reed valve modules having a first set of dimensions, and wherein the plurality of
reed valve modules include one or more second reed valve modules having a second set of
dimensions different from the first set of dimensions.

10

 15. A reed valve module, comprising:
a modular valve body having a plurality of faces and one or more ports;
one or more reed petals each sized to substantially cover one or more of the one or more ports of
the modular valve body; and
15 a modular housing sized for a frictional fit when disposed within a receiving recess with the
modular valve body and the one or more reed petals within and secured by a seat plate.

20

 16. The reed valve module of claim 15, wherein at least one port of the one or more
ports is reinforced by one or more ribs that may also divide the at least one port.

 17. The reed valve module of claim 16, wherein the one or more ribs reinforce the
modular valve body and support the one or more reed petals in a closed position.

 18. The reed valve module of claim 15, further comprising:
25 one or more petal guards positioned next to the one or more reed petals.

 19. The reed valve module of claim 18, wherein the modular housing includes the one
or more petal guards as one or more inner walls of the modular housing.

30 20. The reed valve module of claim 15, wherein the modular housing includes a fluid
conduit having one or more capture bars to help capture debris.

 21. The reed valve module of claim 15, wherein the one or more reed petals comprise a
contiguous single petal that covers a plurality of the one or more ports.

35

5 22. The reed valve module of claim 15, wherein the modular housing includes a protrusion sized to fit into a groove to secure the reed valve module when the modular housing is inserted into a respective receiving recess.

10 23. A reed valve module, comprising:
a modular valve body having a plurality of faces and one or more ports;
one or more reed petals each sized to substantially cover one or more of the one or more ports of
the modular valve body;
wherein the modular valve body and the one or more reed petals are collectively sized for a
frictional fit when disposed within a receiving recess with the modular valve body and the
15 one or more reed petals within.

24. A reed valve assembly, comprising:
a seat plate including one or more fluid conduits and one or more receiving recesses, each
proximate a respective fluid conduit of the one or more fluid conduits in the seat plate,
20 wherein each of the one or more receiving recesses includes a groove; and
one or more reed valve modules, each comprising:
a modular housing including a protrusion sized to fit into the groove to secure the reed
valve module when the modular housing is inserted into a respective one of the one
or more receiving recesses.

25 25. A method of assembling a reed valve module, the method comprising:
obtaining a modular reed valve body including a seating surface, one or more sealing faces, and
one or more fluid conduits leading from the seating surface to the sealing faces;
obtaining at least one reed petal, sized for one or more of the one or more sealing faces;
30 obtaining a modular housing;
placing the at least one reed petal over the one or more of the one or more sealing faces;
placing the modular reed valve body and the at least one reed petal into the modular housing.

26. A method of assembling a reed valve assembly, the method comprising:
35 obtaining one or more reed valve modules;

5 obtaining a seat plate including one or more fluid conduits and one or more receiving recesses,
each of the one or more receiving recesses proximate a respective fluid conduit of the one
or more fluid conduits in the seat plate; and
inserting one of the one or more reed valve modules into a respective receiving recess of the one
or more receiving recesses.

10

27. The method of claim 26, wherein at least one of the one or more reed valve
modules includes a modular housing having a protrusion, and wherein at least one of the
one or more receiving recesses in the seat plate includes a groove, the method further
comprising:

15 fitting the protrusion into the groove to secure the at least one of the one or more reed valve
modules.

28. The method of claim 26, further comprising:
attaching a retaining plate over the seat plate.

20

29. The method of claim 26, further comprising:
removing a retaining plate from the seat plate;
emptying the respective receiving recess of the one or more receiving recesses.

25

30. A compressor, comprising:
a frame;
a plurality of mechanical components disposed with the frame that compress a working fluid; and
at least one modular reed valve assembly coupled to the frame and the plurality of mechanical
components to control the flow of fluid through at least one modular reed valve.

30

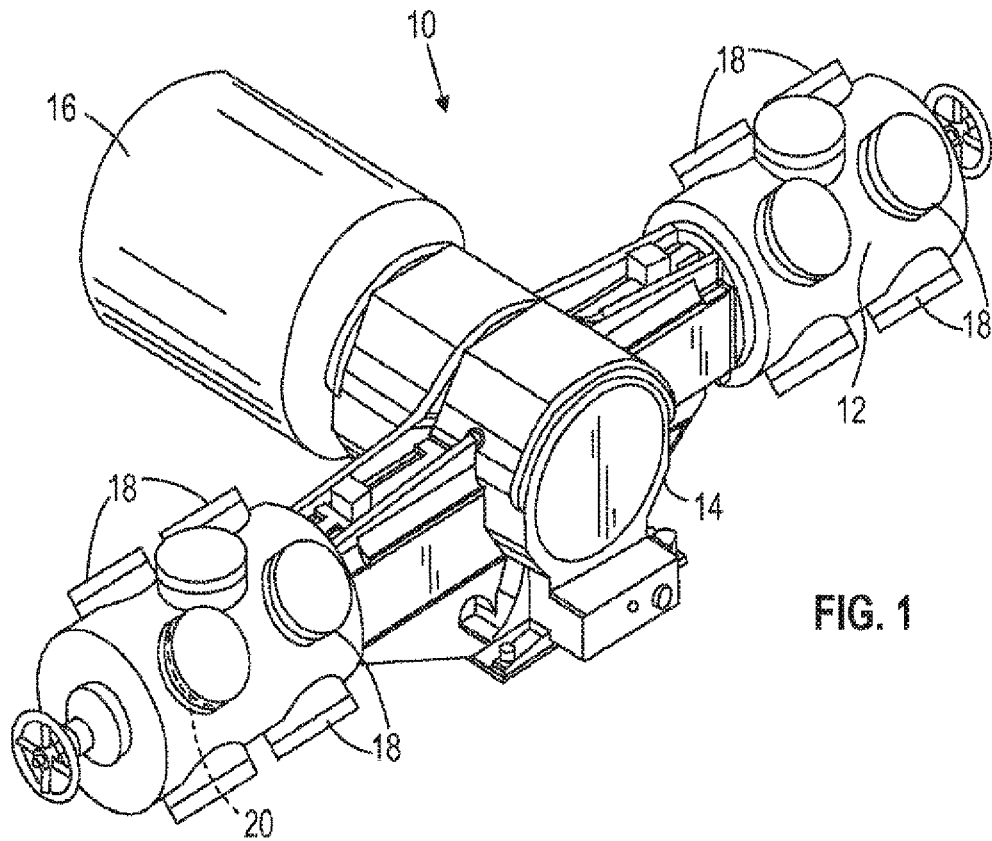

FIG. 1

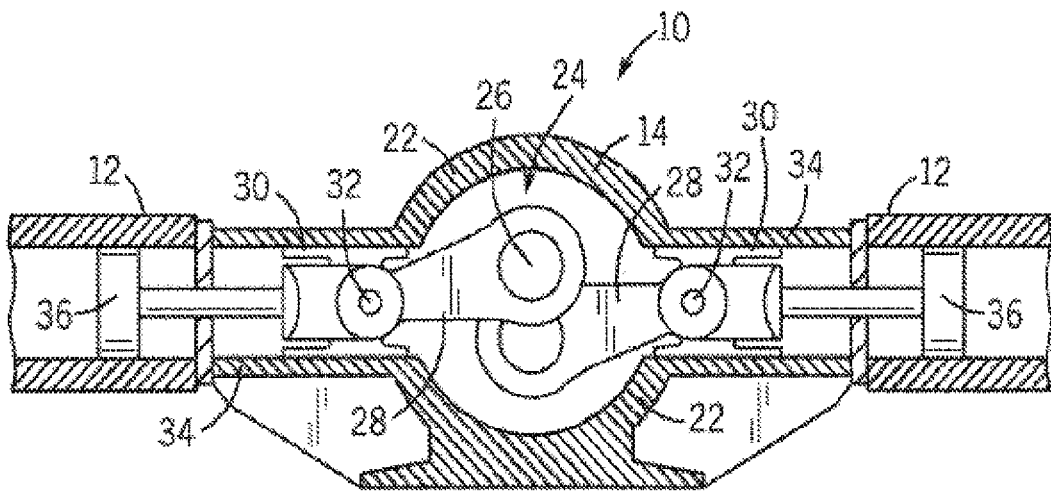

FIG. 2

FIG. 3

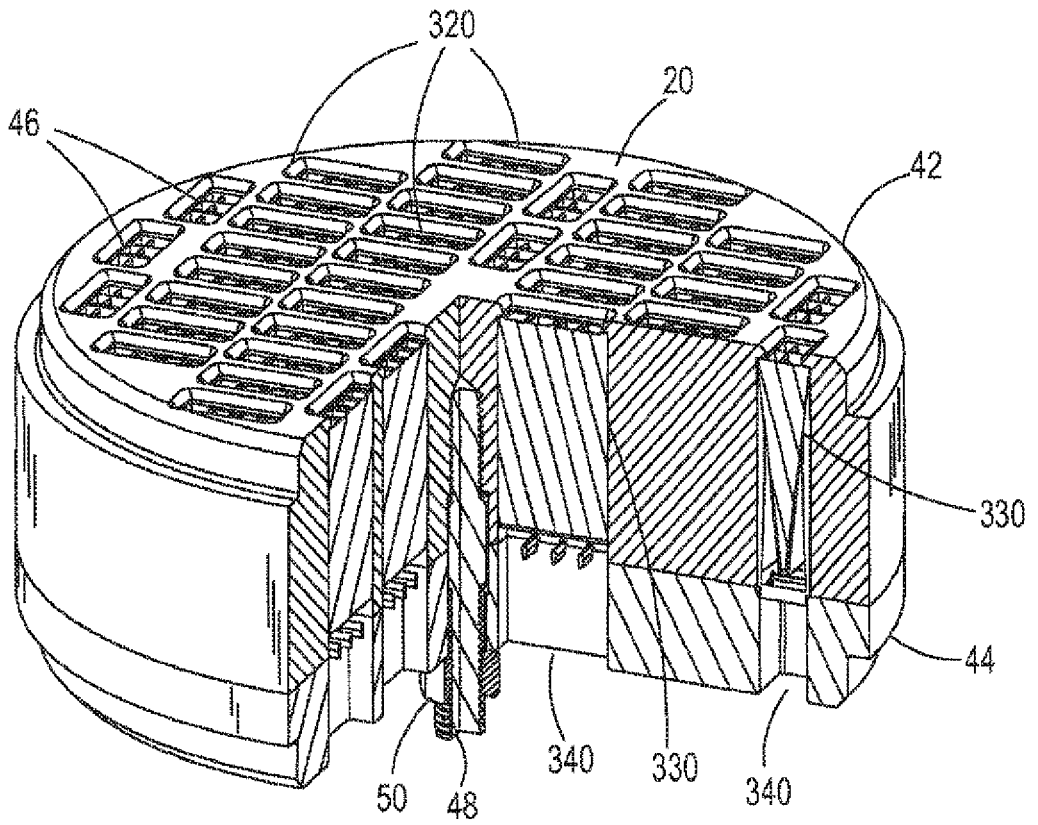

FIG. 13

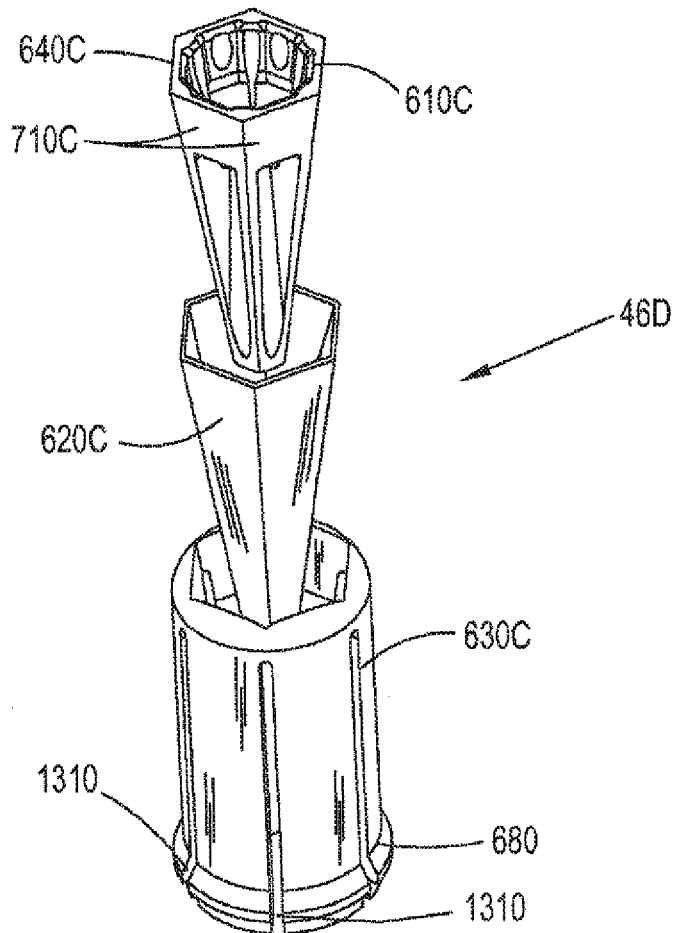
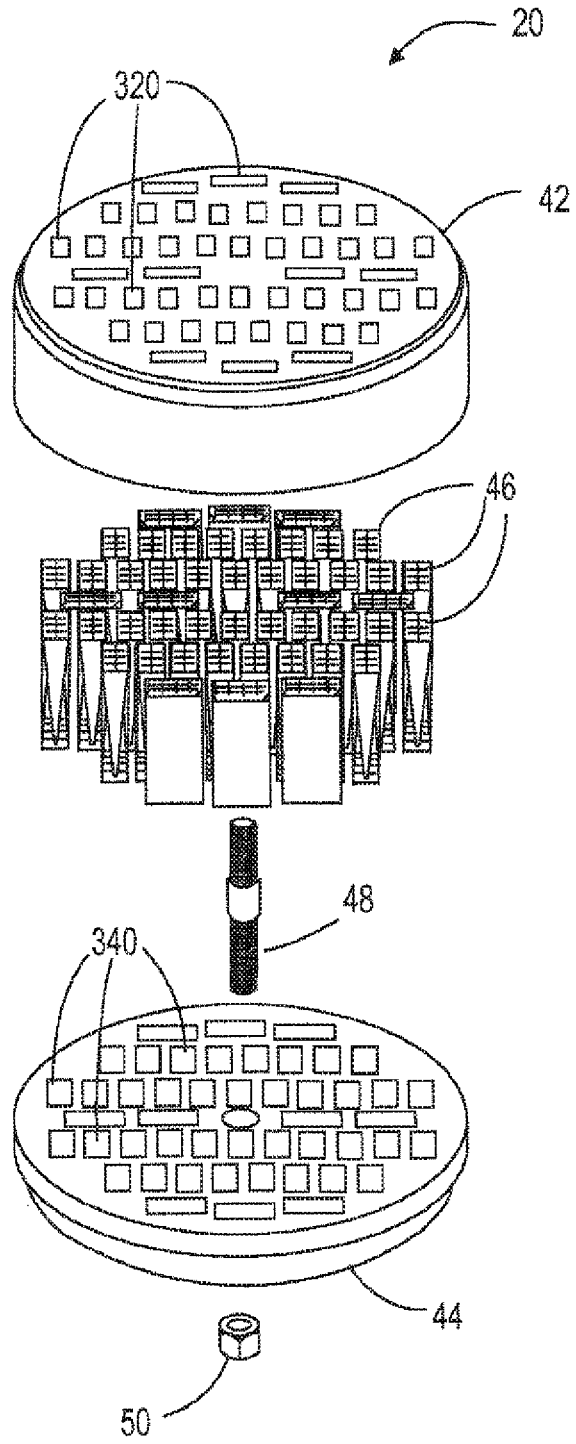
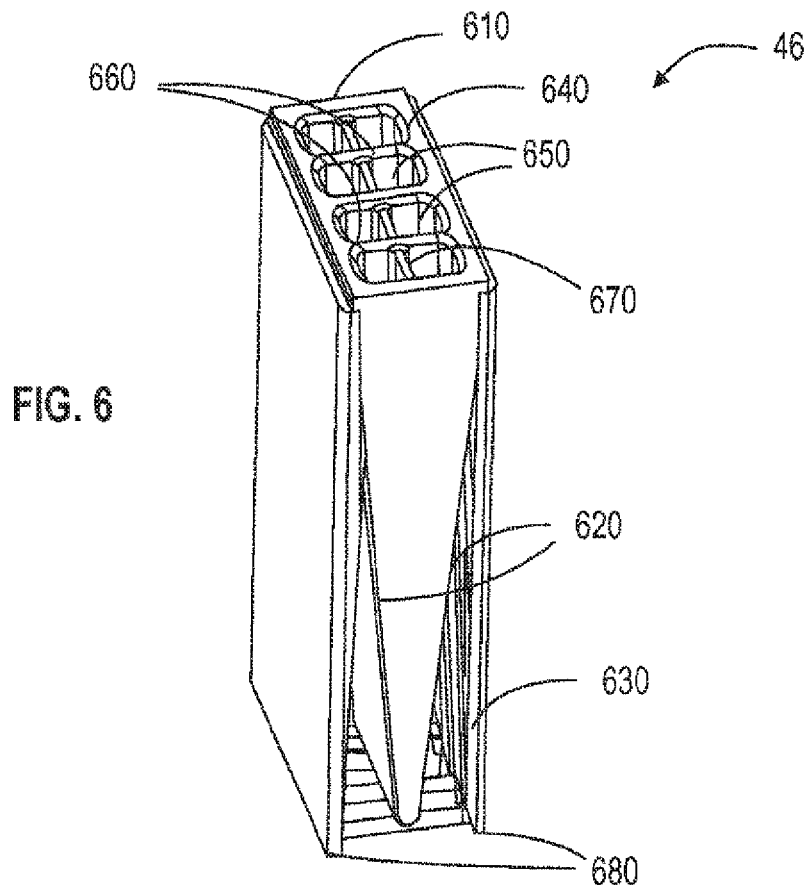
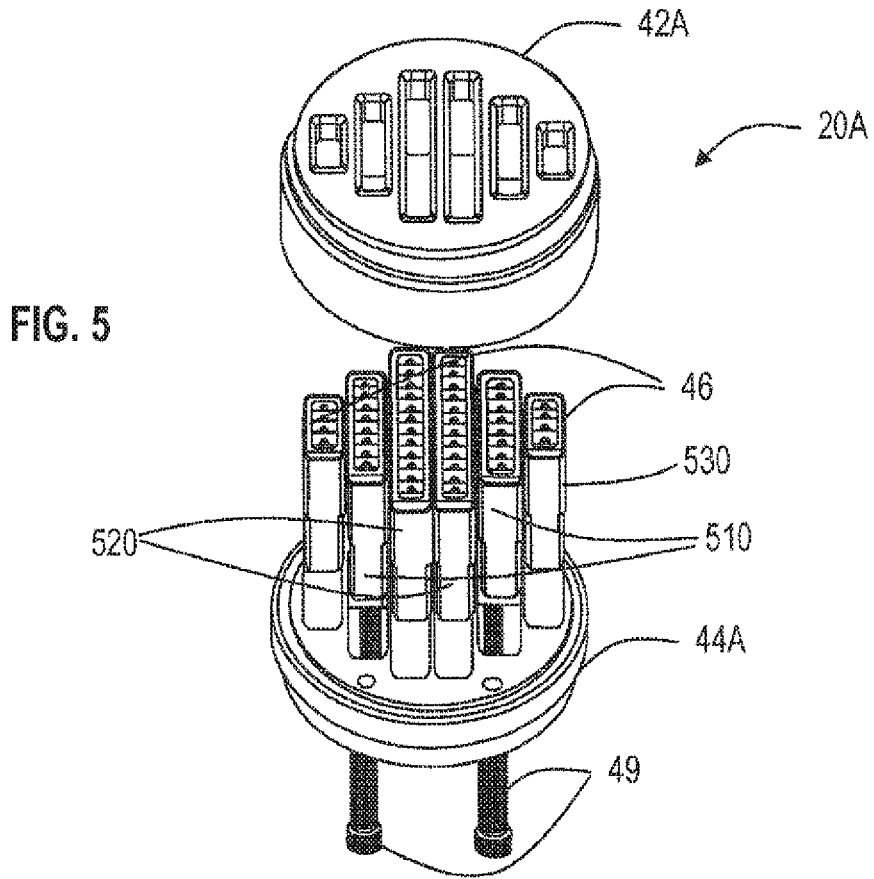

FIG. 4





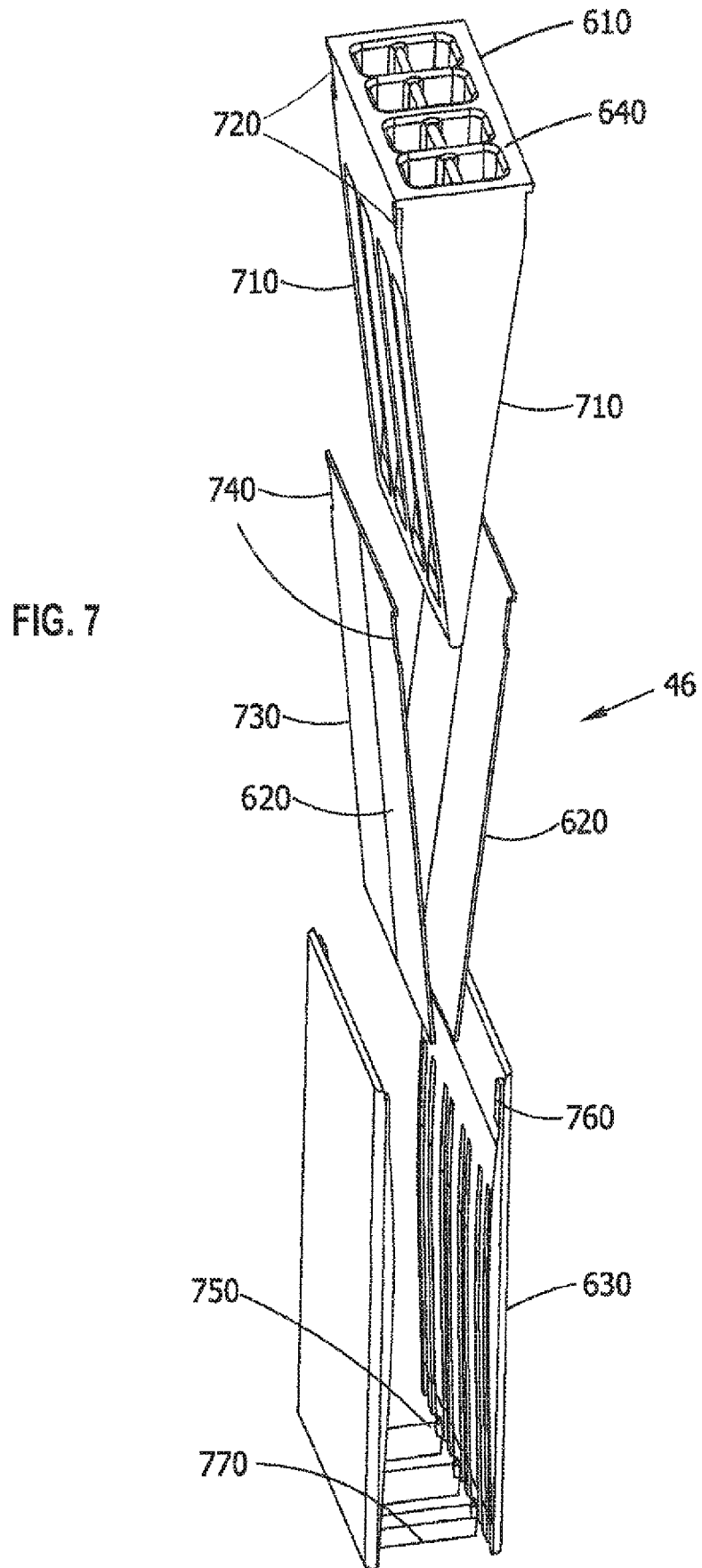

FIG. 8

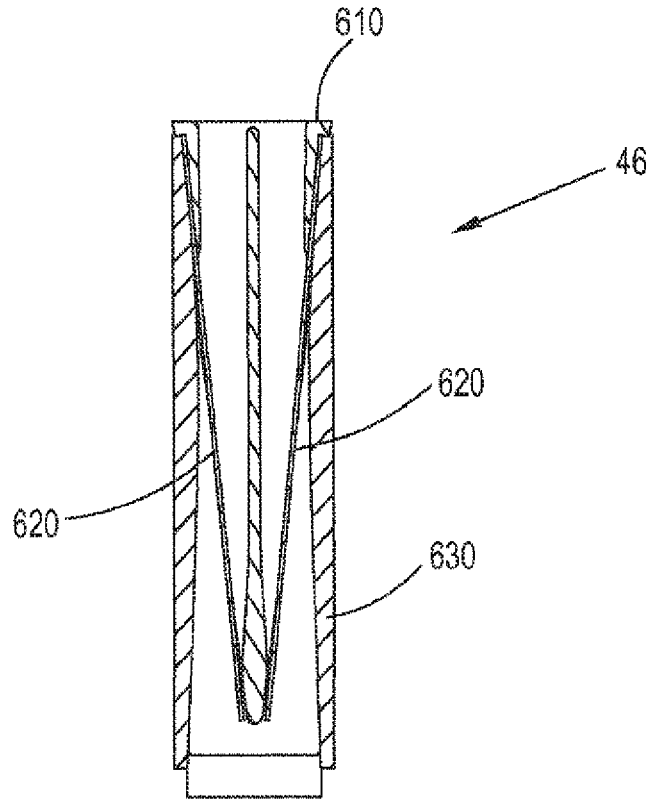

FIG. 9

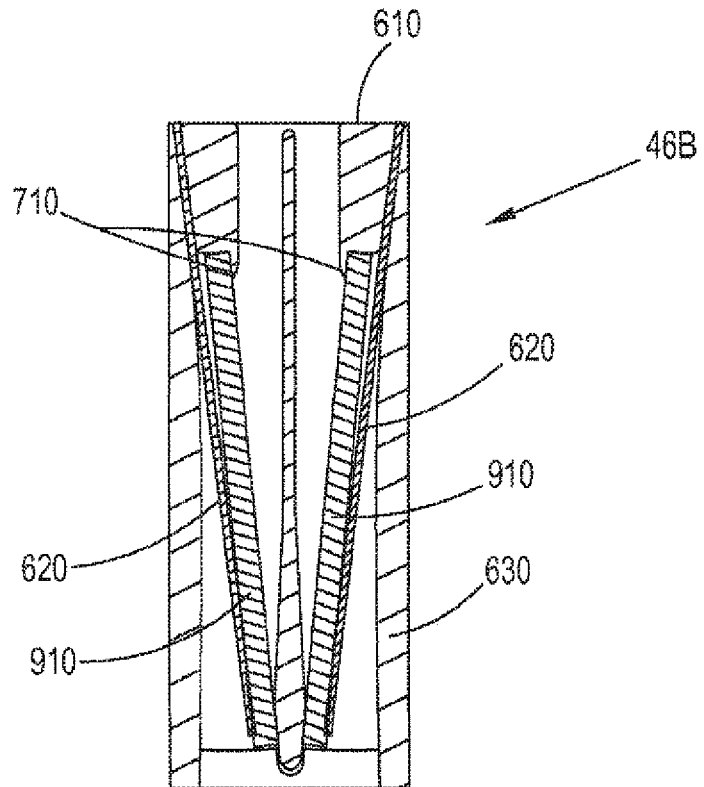
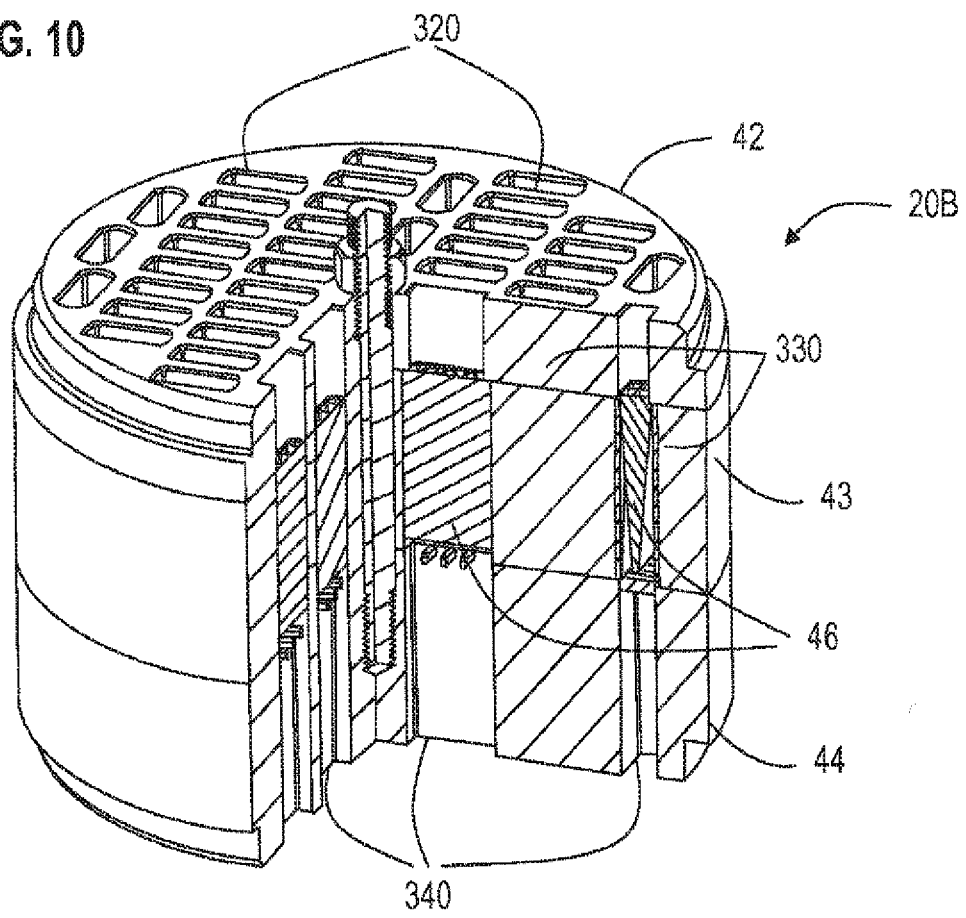
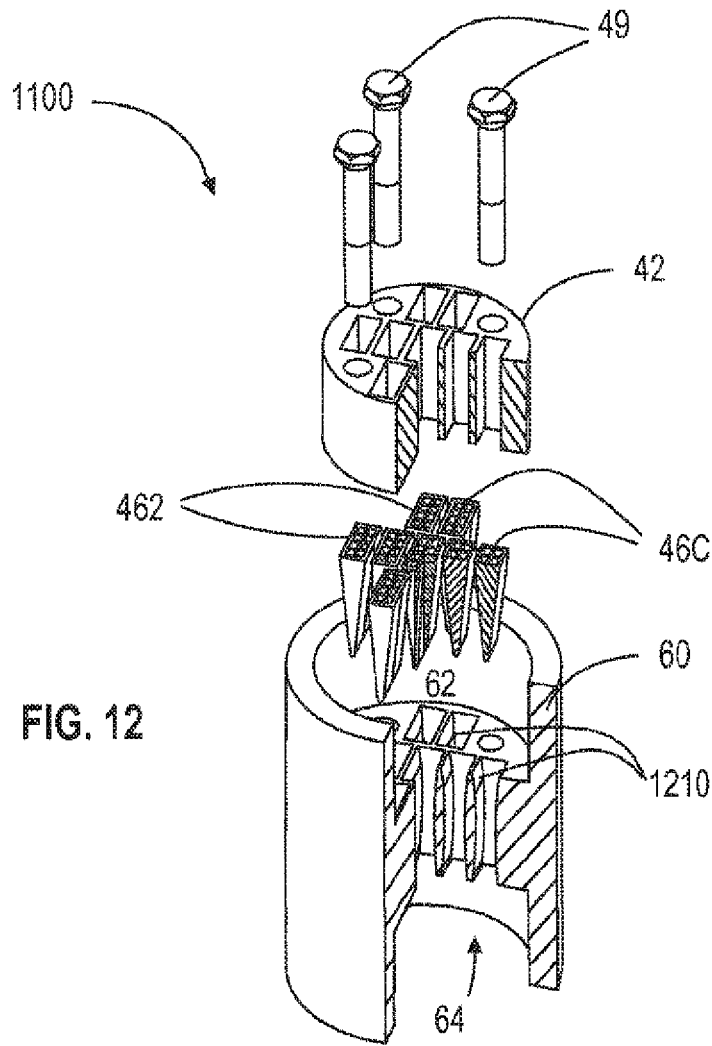
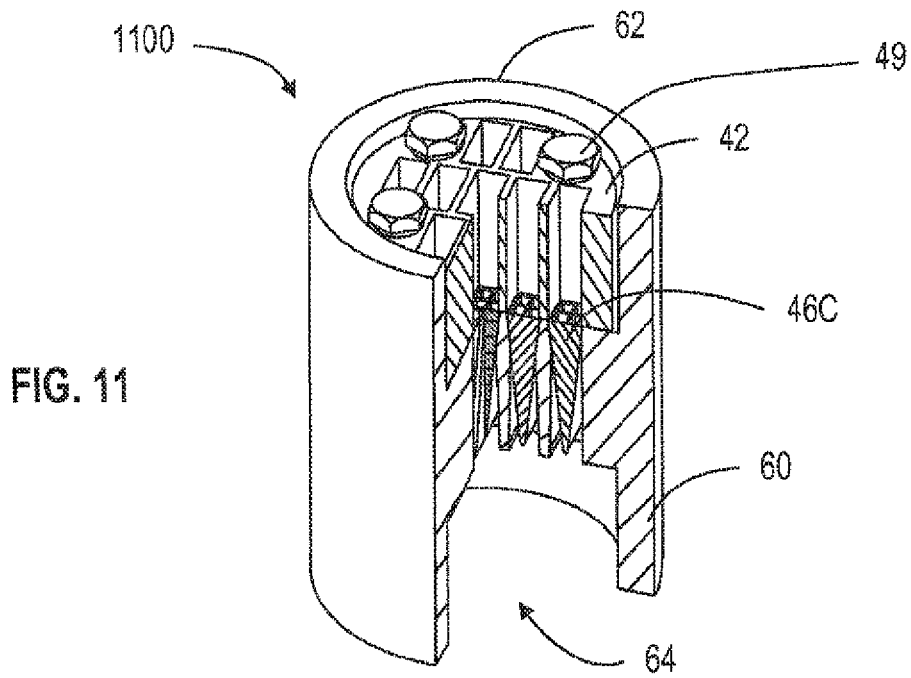

FIG. 10





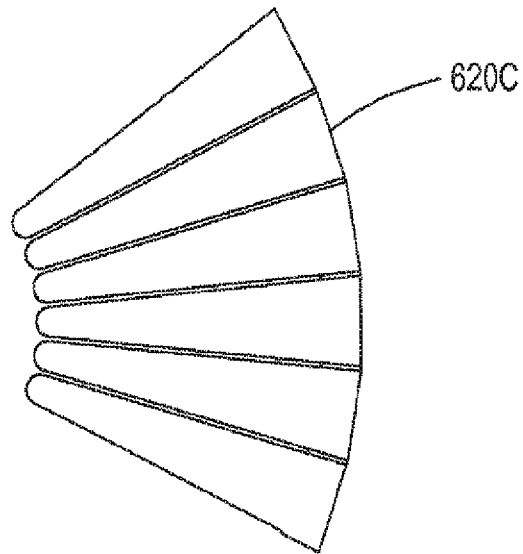

FIG. 14

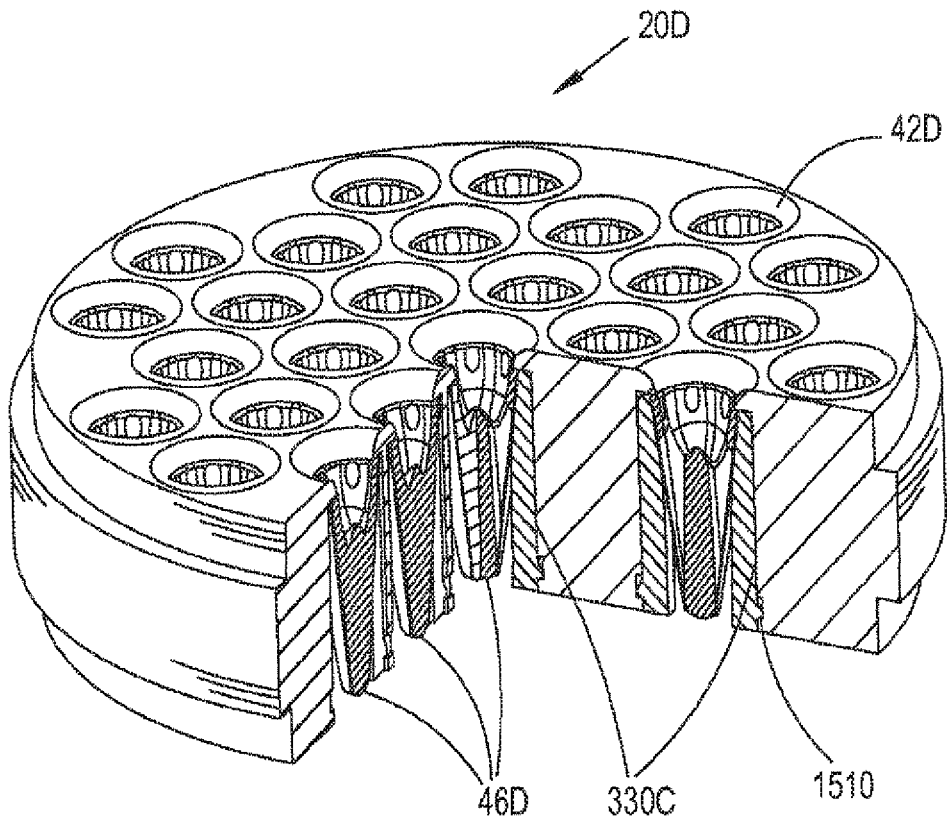

FIG. 15