



HU000030864T2

(19) **HU**(11) Lajstromszám: **E 030 864**(13) **T2****MAGYARORSZÁG**
Szellemi Tulajdon Nemzeti Hivatala**EURÓPAI SZABADALOM**
SZÖVEGÉNEK FORDÍTÁSA

- (21) Magyar ügyszám: **E 13 004441**
- (22) A bejelentés napja: **2013. 09. 12.**
- (96) Az európai bejelentés bejelentési száma:
EP 20130004441
- (97) Az európai bejelentés közzétételi adatai:
EP 2848884 A1 **2015. 03. 18.**
- (97) Az európai szabadalom megadásának meghirdetési adatai:
EP 2848884 B1 **2016. 08. 03.**
- (51) Int. Cl.: **F27D 7/02** (2006.01)
C02F 3/30 (2006.01)
F23J 15/02 (2006.01)
F23N 5/18 (2006.01)
F23N 5/24 (2006.01)

- | | |
|--|---|
| (72) Feltalálók):
Gusberti, Ambrogio, 81669 München (DE) | (73) Jogosult(ak):
Linde Aktiengesellschaft, 80331 München (DE) |
| | (74) Képviselő:
Danubia Szabadalmi és Jogi Iroda Kft., Budapest |

- (54) **Eljárás nyomástartó edény, különösen kemencetérben elrendezett csőspirál inert közeggel történő feltöltésére**

Az európai szabadalom ellen, megadásának az Európai Szabadalmi Közlönyben való meghirdetésétől számított kilenc hónapon belül, felszólalást lehet benyújtani az Európai Szabadalmi Hivatalnál. (Európai Szabadalmi Egyezmény 99. cikk(1))

A fordítást a szabadalmas az 1995. évi XXXIII. törvény 84/H. §-a szerint nyújtotta be. A fordítás tartalmi helyességét a Szellemi Tulajdon Nemzeti Hivatala nem vizsgálta.

(19)



(11)

EP 2 848 884 B1

(12)

EUROPEAN PATENT SPECIFICATION

(45) Date of publication and mention of the grant of the patent:
03.08.2016 Bulletin 2016/31

(51) Int Cl.:
F27D 7/02 ^(2006.01) **C02F 3/30** ^(2006.01)
F23J 15/02 ^(2006.01) **F23N 5/18** ^(2006.01)
F23N 5/24 ^(2006.01)

(21) Application number: **13004441.5**

(22) Date of filing: **12.09.2013**

(54) **Method for inertization of a vessel, particularly in the form of a coil arranged in a furnace**
 Verfahren zum Inertisieren eines Gefäßes, insbesondere einer Spule in einem Ofen
 Procédé d'inertie d'un récipient, en particulier sous la forme d'une bobine disposée dans un four

(84) Designated Contracting States:
AL AT BE BG CH CY CZ DE DK EE ES FI FR GB GR HR HU IE IS IT LI LT LU LV MC MK MT NL NO PL PT RO RS SE SI SK SM TR

(43) Date of publication of application:
18.03.2015 Bulletin 2015/12

(73) Proprietor: **Linde Aktiengesellschaft**
80331 München (DE)

(72) Inventor: **Gusberti, Ambrogio**
81669 München (DE)

(74) Representative: **Gellner, Bernd**
Linde AG
Patente und Marken
Dr.-Carl-von-Linde-Strasse 6-14
82049 Pullach (DE)

(56) References cited:
WO-A1-2013/003884 **FR-A1- 2 973 862**
JP-A- H0 727 483 **JP-A- H07 173 523**
RO-A2- 77 766 **US-A1- 2005 267 710**
US-A1- 2013 026 685

- **DAVID S J ET AL: "STAN", 31 December 2006 (2006-12-31), HANDBOOK OF PETROLEUM PROCESSING, DORDRECHT : SPRINGER, NL, PAGE(S) 1040 - 1053, XP002682364, ISBN: 978-1-4020-2819-9 * the whole document ***
- **HOELZNER K ET AL: "Operation of 20 kWth gas-fired heating boilers with hydrogen, natural gas and hydrogen/natural gas mixtures. First test results from phase 1 (March 1993) of the Neunburg vorm Wald solar hydrogen project", INTERNATIONAL JOURNAL OF HYDROGEN ENERGY, ELSEVIER SCIENCE PUBLISHERS B.V., BARKING, GB, vol. 19, no. 10, 1 October 1994 (1994-10-01), pages 843-851, XP025640419, ISSN: 0360-3199, DOI: 10.1016/0360-3199(94)90200-3 [retrieved on 1994-10-01]**

EP 2 848 884 B1

Note: Within nine months of the publication of the mention of the grant of the European patent in the European Patent Bulletin, any person may give notice to the European Patent Office of opposition to that patent, in accordance with the Implementing Regulations. Notice of opposition shall not be deemed to have been filed until the opposition fee has been paid. (Art. 99(1) European Patent Convention).

Description

[0001] The invention relates to a method for inertization according to claim 1. A system for inertization of a vessel is also discussed.

[0002] Heat is used in the process industry (from oil and gas to fine chemistry) to promote reactions, separation processes or to handle products. Heat can be transferred directly by burning a fuel in a fluid heater and transferring the energy from the combustion to the product contained in a coil or indirectly by heating a media (e.g. oil, water, or steam) and then transferring the energy to the product via a heat exchanger. Particularly, the present invention is concerned with fluid heaters. Fired heaters are defined on the API Std. 560 4th ed. as equipments where the "heat liberated by the combustion of fuels is transferred to fluids (other than water) contained in vessels, e.g. in the form of tubular coils, within an internally insulated enclosure". Excluding water, the fluid is normally flammable. Then, in case the coil breaks, hot hydrocarbons flow into the firing box of the furnace and start burning. The double action of heat released by the uncontrolled combustion on the leak and the internal pressure of the coil can diffuse the crack generating bigger fluid release that can drive also to an explosion.

[0003] Methods and systems for purging coils while being treated inside a furnace are disclosed in JP 07173523 and JP 07027483.

[0004] Actually when such a coil develops a leak (e.g. a rupture) the actions to be taken are the following:

1. stop/reduce the fluid medium (e.g. hydrocarbon) inlet to the coil,
2. reduce combustion in the furnace,
3. reduce the pressure into the system down to the nitrogen network pressure and inject the nitrogen into the coil to displace the liquid out and extinguish the fire
4. stop the fuel to the furnace and shut down the furnace.

[0005] The time lag between steps 2 and 3 depends on the system hold-up. In this time the leak (e.g. rupture) can increase and the uncontrolled fire can extend to other sections of the furnace like the convection section and the flue gas duct or the stack. The uncontrolled fire overheats the structures surrounding the unit, which then potentially collapses.

[0006] Thus, the problem underlying the present invention is to provide for a method and a system, which allow for reduction of said time lag or hold-up.

[0007] This problem is solved by a method having the features of claim 1. Preferred embodiments are stated in the respective sub claims and are described below.

[0008] According to claim 1 the method according to the invention relates to inertization of a vessel, said vessel being a coil arranged in a furnace, said coil having an inlet and an outlet, wherein said inlet is connected to a first conduit and said outlet is connected to a second conduit, wherein a fluid medium is passed through the coil for heating said fluid medium therein, wherein particularly a fuel is combusted in said furnace for heating of said fluid medium flowing through said coil, the vessel having an inlet and an outlet, wherein said inlet is connected to a first conduit and said outlet is connected to a second conduit for passage of a fluid medium through said vessel via said conduits, the method further comprises the steps of: closing a first valve, e.g. a pneumatical failure close, failure open, or failure lock valve (wherein regarding a failure lock valve the valve does not move in case of air failure), of the first conduit upstream of said inlet for blocking passage of said fluid medium into the vessel, and injecting an inert medium, particularly an inert gas, particularly comprising nitrogen, into the first conduit downstream of said first valve as well as into the second conduit downstream of said outlet for inertization of said vessel, wherein said inert medium is injected into said first and second conduit at a pressure being equal to the pressure of said fluid medium in the vessel or at a pressure that differs from said pressure of the fluid medium in the vessel by less than 2 bar, particularly less than 1 bar, particularly less than 0.5 bar. In other words, the pressure of the inert medium (e.g. inert gas) essentially equals the pressure of the fluid medium, but may be a bit lower or higher.

Preferably, the inert medium (e.g. nitrogen or other inert gas) is injected into the broken vessel (e.g. coil) with a velocity ranging between 2 m/s and 20 m/s depending on the physical state of the heated medium (liquid or gas), on the operating conditions of the system and also on the system hold-up. The aim is to completely displace any liquid entrapped in the elbows without further damaging the vessel.

[0009] Preferably, the amount of inert medium (e.g. nitrogen or other inert gas) is enough to purge the vessel about four or five times, i.e., the amount of inert medium or inert gas injected into the vessel is preferably equal to four or five times the vessel volume at the actual conditions (injection pressure and ambient temperature).

[0010] In case of a vessel failure (for instance a rupture with a fluid medium release, particularly hydrocarbons, into the firing box of the furnace), the invention thus advantageously reduces the hold-up of said medium. The inert medium (e.g. nitrogen) injection at said pressure does not need a prior reduction of the operating pressure so that displacement of the residual fluid medium (e.g. hydrocarbons) is possible right from the start leading to a quicker inertization of the environment. Hence, a particular advantage of the present invention is that the reduced hydrocarbons hold-up decreases

the risk of a "domino effect" extending damages to the surrounding components. This is particularly achieved by storing said inert medium at an adequate pressure level that allows for injection into the system before the pressure is lower than that of the (e.g. nitrogen) network employed for inertization, particularly.

5 [0011] According to an embodiment of the method according to the invention inert medium (e.g. inert gas) to be fed into said first conduit is stored in a first pressure tank prior to injection, preferably at said pressure level stated above. Particularly, the first pressure tank is connected to the first conduit via a second valve, which is opened for injecting said inert gas into the first conduit.

10 [0012] Likewise, according to a further embodiment of the method according to the invention, inert medium (e.g. inert gas) to be injected into said second conduit is stored in a second pressure tank prior to injection, particularly at said pressure level stated above. Preferably, the second pressure tank is connected to the second conduit via a third valve, which is opened for injecting said inert gas into the second conduit.

[0013] Further, in order to prevent back flow of said fluid medium into the coil, the second conduit comprises a check valve downstream of the point where said inert gas is injected into the second conduit.

15 [0014] Preferably, the first, second, and/or third valve is designed as a pneumatical valve, i.e., a valve which is designed to be actuated pneumatically, e.g. by means of instrument air or nitrogen. While the first valve preferably is a failure close valve which opens upon actuation (the first valve may also be a failure open or failure lock valve), the second and/or third valve preferably is a failure open valve closing upon actuation. In a further embodiment, said check valve and the first valve may be interchanged. In yet another embodiment, said check valve may be substituted by an (e.g. pneumatical) fourth valve (e.g. a failure close, failure open or failure lock valve, see also above).

20 [0015] Preferably, actuation pressure is provided for these valves by means of two three-way solenoid valves, which are preferably configured such that said (first, second, third and/or fourth) valve is opened/closed or activated (in case of a failure lock valve) when at least one of the solenoids can be electrically activated. Thus, reliability of the first, second and/or third valve is increased since either one of the two solenoids is allowed to fail.

25 [0016] According to yet a further embodiment of the method according to the invention said second and third valves are opened at the same time.

[0017] According to a further embodiment, the first and eventually the fourth valve, when actuated, are closed together before the second and the third valve are opened.

[0018] According to another embodiment of the method according to the invention said fluid medium is combustible. Preferably, said fluid medium comprises one or several combustible hydrocarbons.

30 [0019] According to the invention said vessel is a coil that is arranged in a furnace, particularly in a firing box of the latter, in which a fuel is combusted in the presence of an oxidant (e.g. air or oxygen), so that said fluid medium which is passed through the coil is heated.

35 [0020] According to a further preferred embodiment of the method according to the invention the steps of closing said first valve and injecting said inert medium (e.g. inert gas) into the first and second conduit are conducted when a leak (e.g. a rupture) is detected in said coil. Said leak may for instance be detected by means of a carbon monoxide sensor, which may be for instance arranged in a stack of said furnace through which flue gas generated upon combustion is drawn off the furnace. Further, preferably, the fuel to the system is not completely stopped when a fire is detected, since in case the flammable fluid medium is not burned in the firing box an explosive atmosphere may be created. Preferably, the system is actuated manually, but can also be activated automatically based on the available information, e.g. CO content in the flue gas, furnace operating pressure or other suitable signals.

40 [0021] According to a further embodiment of the method according to the invention, said inert medium (e.g. inert gas) is injected into the first and second conduit so as to push out said fluid medium out of the coil through said leak (e.g. rupture). Since inert medium is injected into the system on both sides of the coil as described above, said residual fluid medium can be pushed out of the ruptured coil more effectively.

45 [0022] According thereto, to effectively render said vessel (e.g. coil) inert, a first pressure tank for storing an inert medium (e.g. inert gas) is provided, which first pressure tank is connected to said first conduit via a second valve, as well as a second pressure tank for storing an inert medium (e.g. inert gas), which second pressure tank is connected to said second conduit via a third valve, wherein the system is configured to inject said inert medium, particularly inert gas, particularly comprising nitrogen, out of the pressure tanks into the vessel via the first and second conduit for inertization of the vessel, particularly when a leak of said vessel is detected and/or the system is activated by an operator, particularly so as to push out said fluid medium out of vessel through said leak by means of the injected inert gas.

50 [0023] According to the invention, said vessel is a tubular coil arranged in a furnace of said system, particularly in a firing box of said furnace, wherein the system is configured for passing said fluid medium through said coil for transferring heat to said fluid medium, wherein particularly the furnace is configured to combust a fuel in said furnace (particularly in said firing box) for heating of said fluid medium flowing through said coil.

55 [0024] Further, in order to prevent back flow of said fluid medium into the vessel (e.g. coil), the second conduit preferably comprises a check or an automatic ON-OFF fourth valve (see above) downstream of the point where said inert gas flows into the second conduit. The position of the first valve and the check valve may also be interchanged (see above).

[0025] According to a further embodiment according to the invention, the first, the second, the third and/or the fourth valve is preferably designed as a pneumatical valve, which is actuated pneumatically, e.g. by means of instrument air or nitrogen. While the first and eventually the fourth valve are preferably failure close valves which open upon actuation (the first and/or fourth valve may also be a failure open or a failure lock valve), the second and the third valve are preferably failure open valves closing upon actuation. As indicated above, actuation of the system is preferably conducted by an (e.g. plant) operator of the system once a leak of the vessel/coil is detected. The valves will be interlocked in order to open/close the valves in the right sequence.

[0026] Preferably, actuation pressure is provided for these valves by means of two three-way solenoid valves, which are configured such that said first, second third and/or fourth valve is opened/closed or activated when at least one of the solenoids can be activated by means of electric power. Thus, reliability of the first, second and/or third valve is increased since either one of the two solenoids is allowed to fail, respectively.

[0027] Further features and advantages of the invention shall be described by means of detailed descriptions of embodiments with reference to the Figures, wherein

Fig. 1 shows a schematical illustration of the method according to the invention and of the system which has been discussed;

Fig. 2 shows a failure close valve used as first valve of the system shown in Fig. 1;

Fig. 3 shows a failure open valve used as second and third valve of the system shown in Fig. 1;

Fig. 4 shows a modification of the system and method illustrated in Fig. 1, wherein the first and the check valve are interchanged;

Fig. 5 shows a modification of the system and method illustrated in Fig. 1, wherein the check valve is interchanged by an (e.g. pneumatical) fourth valve being preferably either a failure close, failure open or failure lock valve.

[0028] Fig. 1 shows in conjunction with Figs. 2 and 3 a system 1 for rendering a vessel in the form of a tubular coil 40 inert that is arranged in a firing box of a furnace 2, in which a fuel F is combusted in the presence of an oxidant O like air for instance. The heat produced upon combustion of said fuel F is transferred to a combustible fluid medium M comprising combustible hydrocarbons flowing through said tubular coil 40 for heating of said fluid medium M.

[0029] Said coil 40 comprises an inlet 41 connected to a first conduit 22 as well as an outlet 42 connected to a second conduit 32 so that fluid medium M can be fed into the coil 40 via the first conduit 22 and drawn of the coil 40 via the second conduit 32. In order to stop or reduce passage of fluid medium M into the coil 40, the first conduit 22 preferably comprises a first valve 10 for reducing or stopping flow of fluid medium M into the coil 40. Further, for preventing back flow of fluid medium M into the coil 40, a check valve 50 is provided in the second conduit 32.

[0030] Now, in case of a rupture R of the coil, a part of the fluid medium M is discharged into the furnace 2 which may lead to an uncontrolled burning of the fluid medium M causing damage to the furnace 2 and eventually surrounding components.

[0031] In order to quickly render the coil 40 and components connected thereto inert, the system 1 thus comprises a first pressure tank 21 being connected via a second valve 20 to the first conduit 22 downstream of the first valve 10 as well as a second pressure tank 31 being connected to the second conduit 32 upstream of said check valve 50. The pressure tanks 21, 31 are designed for storing an inert medium, particularly an inert gas G, here e.g. nitrogen, and allow for injecting the latter at a pressure level into the first and second conduit 22, 32 that is essentially equal to the pressure level of the fluid medium M in the coil 40. This allows for pushing out the fluid medium M through the rupture R of the coil 40 and for inertization of the coil 40 as well as components being in fluid connection with the coil 40 like the first and second conduit 22, 32 in a relatively short amount of time, since the pressure of the fluid medium M, i.e., the operating pressure, needs not be decreased in the first place in order to be able to inject said inert gas G into the coil 40 and to push out the residual fluid medium M through the rupture R.

[0032] For detecting such a rupture R in the coil 40, the furnace 2 may comprise a CO sensor 4 provided in a stack 3 of the furnace 2 via which stack 3 flue gas generated in the furnace 2 due to combustion of said fuel F is drawn off the furnace 2. Preferably, said sensor 4 is designed to detect an increase in CO generation due to combustion of fluid medium M that is discharged through rupture R into the furnace 2.

[0033] Once a rupture R is detected in the coil 40, an operator may trigger injection of nitrogen G into the coil 40 manually. The system 1 will then automatically close the first valve 10 for blocking passage of fluid medium M into the coil 40, reduce flow of fuel F and/or oxidant O into the furnace 2 and open the second and third valve 20, 30 so that nitrogen G flows via the first and second conduit 22, 32 into the coil 40 and pushes out residual fluid medium M through said rupture R thus rendering the coil 40 inert.

[0034] As shown in Fig. 4, the first valve 10 and the check valve 50 may also be interchanged. Further as shown in Fig. 5, instead of a check valve 50, also a fourth (e.g. pneumatical) valve 10' may be used. The first 10 and the fourth valve 10' can be (e.g. pneumatical) failure close, failure open or failure lock valves. The second and the third valves 20, 30 are preferably (e.g. pneumatical) failure open valves.

5 [0035] In the embodiment shown in Fig. 2, the first valve 10 is a pneumatically actuated failure close valve, which is actuated by means of a first and a second solenoid three-way valve 101, 102, which solenoid valves 101, 102 are configured such that when the solenoids S of the first and the second solenoid valve 101, 102 are in a resting position, a first flow path 103 is pressurized with a gas (e.g. instrument gas or nitrogen), which however is not in fluid communication with an actuating means 106 for closing the first valve 10. In case both solenoids S are electrically actuated, a second flow path 104 is pressurized with said gas which pressurizes said actuating means 106 which then closes the first valve. In case only one of the solenoids S can be electrically actuated, the respective second or third flow path 104, 105 pressurizes the actuating means 106 with said gas, which actuating means 106 then closes the first valve 10. Thus, merely one functioning solenoid S is needed to operate the first valve 10 successfully.

10 [0036] The second and the third valve as shown in Fig. 3 are operated accordingly, i.e., when the solenoids S of the first and the second solenoid valve 201, 202 are in a resting position, a first flow path 203 is pressurized, which is not in fluid communication with the actuating means 206 for opening the second/third valve 20, 30. In case both solenoids S are electrically actuated, the second flow path 204 pressurizes said actuating means 206 with gas, which actuating means 206 then closes the second/third valve 20, 30. In case only one of the solenoids S can be electrically actuated, the respective second or third flow path 204, 205 pressurizes the actuating means 206 with said gas, which actuating means 206 then closes the second/third valve 20, 30. Thus, again, merely one functioning solenoid S is needed to close the second/third valve 20, 30 successfully.

15 [0037] As a result, the method according to the invention particularly achieves the advantageous technical effect according to which the fluid medium (e.g. hydrocarbons) hold-up in the coil 40 can be lowered, thus reducing the risk of a "domino effect" extending the damages to the surrounding. In this regard, nitrogen G is stored at an adequate pressure for injection into the system 1 before the pressure is lower than the nitrogen network.

Reference Numerals

30	1	System for inertization
	2	Furnace
	3	Stack
	4	Sensor
35	10	First valve (e.g. failure close, open or lock)
	20	Second valve (e.g. failure open)
	10'	fourth valve (e.g. failure close, open or lock)
40	21	First pressure tank
	22	First conduit
	30	Third valve (e.g. failure open)
	31	Pressure tank
45	32	Second conduit
	40	Vessel (e.g. coil)
	41	Inlet of vessel
	42	Outlet of vessel
50	50	Check valve
	101, 201	First solenoid valve
	102, 202	Second solenoid valve
55	103, 203	First flow path
	104, 204	Second flow path
	105, 205	Third flow path

(continued)

106, 206	Actuating means
F	Fuel
M	Fluid medium (e.g. combustible)
O	Oxidant
R	Leak
S	Solenoid

Claims

- 15 1. Method for inertization of a vessel, said vessel is a coil arranged in a furnace (2), said vessel (40) having an inlet (41) and an outlet (42), wherein said inlet (41) is connected to a first conduit (22) and said outlet (42) is connected to a second conduit (32), wherein a fluid medium (M) is passed through the coil (40) for heating said fluid medium (40) therein, comprising the steps of:
- 20 - closing a first valve (10) of the first conduit (22) upstream of said inlet (41) for blocking passage of said fluid (M) medium into the vessel (40),
 - injecting an inert medium (G) into the first conduit (22) downstream of said first valve (10) as well as into the second conduit (32) downstream of said outlet (42) for inertization of said vessel (40), and
 - wherein said inert medium (G) is injected into said first and second conduit (22, 32) at a pressure being equal to the pressure of said fluid medium (M) in the vessel (40) or at a pressure that differs from said pressure of the fluid medium (M) in the vessel (40) by less than 2 bar.
- 25 2. Method according to claim 1, **characterized in that** inert medium (G) to be injected into said first conduit (22) is stored in a first pressure tank (21) prior to injection, wherein the first pressure tank (21) is connected to the first conduit (22) via a second valve (20), particularly in the form of a pneumatical valve, wherein the second valve (20) is opened for injecting said inert medium (G) into the first conduit (22).
- 30 3. Method according to one of the preceding claims, **characterized in that** inert medium (G) to be injected into said second conduit (32) is stored in a second pressure tank (31) prior to injection, wherein the second pressure tank (32) is connected to the second conduit (32) via a third valve (30), particularly in the form of a pneumatical valve, wherein the third valve (30) is opened for injecting said inert medium (G) into the second conduit (32).
- 35 4. Method according to claims 2 and 3, **characterized in that** said second and third valves (20, 30) are opened at the same time.
- 40 5. Method according to one of the claims 2 to 4, **characterized in that** the first valve (10) is closed before opening of the second valve (20) and/or third valve (30), wherein particularly also a fourth valve (10') of the second conduit (32), which fourth valve (10') is arranged downstream of said outlet (42) and downstream of the point where inert medium (G) is injected into the second conduit (32), is closed before opening of the second valve (20) and/or third valve (30).
- 45 6. Method according to one of the preceding claims, **characterized in that** said fluid medium (M) is combustible.
- 50 7. Method according to one of the preceding claims, **characterized in that** said fluid medium (M) comprises a hydrocarbon.
8. Method according to one of the preceding claims, **characterized in that** the steps of closing said first valve (10), and particularly said fourth valve (10'), and injecting said inert medium (G) are conducted when a leak (R) is detected in said vessel (40).
- 55 9. Method according to claim 8, **characterized in that** said inert medium (G) is injected into the first and second conduit (22, 32) so as to push said fluid medium (M) out of the coil (40) through said leak (R).

10. Method according to one of the preceding claims, **characterized in that** a fuel (F) is combusted in said furnace (2) for heating of said fluid medium (M) flowing through said coil (40).
- 5 11. Method according to one of the preceding claims, **characterized in that**, said inert medium (G) is an inert gas, particularly nitrogen.
- 10 12. Method according to one of the preceding claims, **characterized in that**, said inert medium (G) is injected into said first and second conduit (22, 32) at a pressure that differs from said pressure of the fluid medium (M) in the vessel (40) by less than 1 bar.
- 15 13. Method according to one of the preceding claims, **characterized in that**, said inert medium (G) is injected into said first and second conduit (22, 32) at a pressure that differs from said pressure of the fluid medium (M) in the vessel (40) by less than 0.5 bar.

Patentansprüche

- 20 1. Verfahren zum Inertisieren eines Behälters, wobei der Behälter eine in einem Ofen (2) angeordnete Rohrschlange ist, wobei der Behälter (40) einen Einlass (41) und einen Auslass (42) aufweist, wobei der Einlass (41) mit einer ersten Leitung (22) verbunden ist und wobei der Auslass (42) mit einer zweiten Leitung (32) verbunden ist, wobei ein Fluidmedium (M) durch die Rohrschlange (40) geleitet wird, um das Fluidmedium (40) darin zu erhitzen, wobei das Verfahren die folgenden Schritte umfasst:
- 25 - Schließen eines ersten Ventils (10) der ersten Leitung (22) stromaufwärts des Einlasses (41) zum Blockieren eines Durchgangs des Fluidmediums (M) in den Behälter (40), und
 - Einspritzen eines inerten Mediums (G) in die erste Leitung (22) stromabwärts des ersten Ventils (10) sowie in die zweite Leitung (32) stromabwärts des Auslasses (42) zum Inertisieren des Behälters (40),
 - wobei das inerte Medium (G) in die erste und zweite Leitung (22, 32) mit einem Druck, der dem Druck des Fluidmediums (M) in dem Behälter (40) gleicht, oder mit einem Druck, der sich von dem Druck des Fluidmediums (M) in dem Behälter (40) um weniger als 2 bar unterscheidet, eingespritzt wird.
- 30 2. Verfahren nach Anspruch 1, **dadurch gekennzeichnet, dass** das inerte Medium (G), das in die erste Leitung (22) gespritzt werden soll, vor einem Einspritzen in einem ersten Drucktank (21) aufbewahrt wird, wobei der erste Drucktank (21) mit der ersten Leitung (22) über ein zweites Ventil (20), insbesondere in der Form eines Druckluftventils, verbunden ist, wobei das zweite Ventil (20) zum Einspritzen des inerten Mediums (G) in die erste Leitung (22) geöffnet wird.
- 35 3. Verfahren nach einem der vorhergehenden Ansprüche, **dadurch gekennzeichnet, dass** das inerte Medium (G), das in die zweite Leitung (32) gespritzt werden soll, vor einem Einspritzen in einem zweiten Drucktank (31) aufbewahrt wird, wobei der zweite Drucktank (32) mit der zweiten Leitung (32) über ein drittes Ventil (30), insbesondere in der Form eines Druckluftventils, verbunden ist, wobei das dritte Ventil (30) zum Einspritzen des inerten Mediums (G) in die zweite Leitung (32) geöffnet wird.
- 40 4. Verfahren nach Anspruch 2 und 3, **dadurch gekennzeichnet, dass** das zweite und das dritte Ventil (20, 30) gleichzeitig geöffnet werden.
- 45 5. Verfahren nach einem der Ansprüche 2 bis 4, **dadurch gekennzeichnet, dass** das erste Ventil (10) geschlossen wird, bevor das zweite Ventil (20) und/oder das dritte Ventil (30) geöffnet werden, wobei insbesondere auch ein viertes Ventil (10') der zweiten Leitung (32) geschlossen wird, bevor das zweite Ventil (20) und/oder das dritte Ventil (30) geöffnet werden, wobei das vierte Ventil (10) stromabwärts des Auslasses (42) und stromabwärts des Punktes, an dem das inerte Medium (G) in die zweite Leitung (32) eingespritzt wird, angeordnet ist.
- 50 6. Verfahren nach einem der vorhergehenden Ansprüche, **dadurch gekennzeichnet, dass** das Fluidmedium (M) brennbar ist.
- 55 7. Verfahren nach einem der vorhergehenden Ansprüche, **dadurch gekennzeichnet, dass** das Fluidmedium (M) Kohlenwasserstoff umfasst.

EP 2 848 884 B1

8. Verfahren nach einem der vorhergehenden Ansprüche, **dadurch gekennzeichnet, dass** die Schritte des Schließens des ersten Ventils (10) und insbesondere des vierten Ventils (10') und des Einspritzens des inerten Mediums (G) ausgeführt werden, wenn in dem Behälter (40) ein Leck (R) detektiert wird.
- 5 9. Verfahren nach Anspruch 8, **dadurch gekennzeichnet, dass** das inerte Medium (G) in die erste und zweite Leitung (22, 32) so eingespritzt wird, dass das Fluidmedium (M) durch das Leck (R) aus der Rohrschlange (40) gedrückt wird.
- 10 10. Verfahren nach einem der vorhergehenden Ansprüche, **dadurch gekennzeichnet, dass** zum Erhitzen des Fluidmediums (M), das durch die Rohrschlange (40) strömt, Brennstoff (F) in dem Ofen (2) verbrannt wird.
- 10 11. Verfahren nach einem der vorhergehenden Ansprüche, **dadurch gekennzeichnet, dass** das inerte Medium (G) ein Inertgas, insbesondere Stickstoff ist.
- 15 12. Verfahren nach einem der vorhergehenden Ansprüche, **dadurch gekennzeichnet, dass** das inerte Medium (G) in die erste und zweite Leitung (22, 32) mit einem Druck, der sich von dem Druck des Fluidmediums (M) in dem Behälter (40) um weniger als 1 bar unterscheidet, eingespritzt wird.
- 20 13. Verfahren nach einem der vorhergehenden Ansprüche, **dadurch gekennzeichnet, dass** das inerte Medium (G) in die erste und zweite Leitung (22, 32) mit einem Druck, der sich von dem Druck des Fluidmediums (M) in dem Behälter (40) um weniger als 0,5 bar unterscheidet, eingespritzt wird.

Revendications

- 25 1. Procédé d'inertisation d'un récipient, ledit récipient étant une bobine disposée dans un four (2), ledit récipient (40) comprenant une entrée (41) et une sortie (42), dans lequel ladite entrée (41) est connectée à un premier conduit (22) et ladite sortie (42) est connectée à un second conduit (32), dans lequel on fait passer un milieu fluide (M) à travers la bobine (40) dans le but de chauffer ledit milieu fluide (40) dans celle-ci, comprenant les étapes suivantes:
- 30 - fermer une première soupape (10) du premier conduit (22) en amont de ladite entrée (41) afin de bloquer le passage dudit fluide (M) dans le récipient (40),
- injecter un milieu inerte (G) dans le premier conduit (22) en aval de ladite première soupape (10) ainsi que dans ledit second conduit (32) en aval de ladite sortie (42) afin de rendre inerte ledit récipient (40), et
35 - dans lequel ledit milieu inerte (G) est injecté dans lesdits premier et second conduits (22, 32) à une pression qui est égale à la pression dudit milieu fluide (M) dans le récipient (40) ou à une pression qui diffère de ladite pression du milieu fluide (M) dans le récipient (40) de moins de 2 bars.
- 40 2. Procédé selon la revendication 1, **caractérisé en ce que** le milieu inerte (G) à injecter dans ledit premier conduit (22) est stocké dans un premier réservoir de pression (21) avant l'injection, dans lequel le premier réservoir de pression (21) est connecté au premier conduit (22) par l'intermédiaire d'une deuxième soupape (20), en particulier sous la forme d'une soupape pneumatique, dans lequel la deuxième soupape (20) est ouverte pour injecter ledit milieu inerte (G) dans le premier conduit (22).
- 45 3. Procédé selon l'une des revendications précédentes, **caractérisé en ce que** le milieu inerte (G) à injecter dans ledit second conduit (32) est stocké dans un deuxième réservoir de pression (31) avant l'injection, dans lequel le deuxième réservoir de pression (31) est connecté au second conduit (32) par l'intermédiaire d'une troisième soupape (30), en particulier sous la forme d'une soupape pneumatique, dans lequel la troisième soupape (30) est ouverte pour injecter ledit milieu inerte (G) dans le second conduit (32).
- 50 4. Procédé selon les revendications 2 et 3, **caractérisé en ce que** lesdites deuxième et troisième soupapes (20, 30) sont ouvertes en même temps.
- 55 5. Procédé selon l'une des revendications 2 à 4, **caractérisé en ce que** la première soupape (10) est fermée avant l'ouverture de la deuxième soupape (20) et/ou de la troisième soupape (30), dans lequel en particulier aussi une quatrième soupape (10') du second conduit (32), ladite quatrième soupape (10) étant disposée en aval de ladite sortie (42) et en aval du point où le milieu inerte (G) est injecté dans le second conduit (32), est fermée avant l'ouverture de la deuxième soupape (20) et/ou de la troisième soupape (30).

EP 2 848 884 B1

6. Procédé selon l'une des revendications précédentes, **caractérisé en ce que** ledit milieu fluide (M) est combustible.
7. Procédé selon l'une des revendications précédentes, **caractérisé en ce que** ledit milieu fluide (M) comprend un hydrocarbure.
- 5
8. Procédé selon l'une des revendications précédentes, **caractérisé en ce que** les étapes de fermeture de ladite première soupape (10), et en particulier de ladite quatrième soupape (10'), et d'injection dudit milieu inerte (G) sont exécutées lorsqu'une fuite (R) est détectée dans ledit récipient (40).
- 10
9. Procédé selon la revendication 8, **caractérisé en ce que** ledit milieu inerte (G) est injecté dans les premier et second conduits (22, 32) de manière à pousser ledit milieu fluide (M) hors de la bobine (40) par l'intermédiaire de ladite fuite (R).
- 15
10. Procédé selon l'une des revendications précédentes, **caractérisé en ce qu'**un combustible (F) est brûlé dans ledit four (2) afin de chauffer ledit milieu fluide (M) qui s'écoule à travers ladite bobine (40).
11. Procédé selon l'une des revendications précédentes, **caractérisé en ce que** ledit milieu inerte (G) est un gaz inerte, en particulier l'azote.
- 20
12. Procédé selon l'une des revendications précédentes, **caractérisé en ce que** ledit milieu inerte (G) est injecté dans lesdits premier et second conduits (22, 32) à une pression qui diffère de ladite pression du milieu fluide (M) dans le récipient (40) de moins de 1 bar.
- 25
13. Procédé selon l'une des revendications précédentes, **caractérisé en ce que** ledit milieu inerte (G) est injecté dans lesdits premier et second conduits (22, 32) à une pression qui diffère de ladite pression du milieu fluide (M) dans le récipient (40) de moins de 0,5 bar.
- 30
- 35
- 40
- 45
- 50
- 55

Figure 1

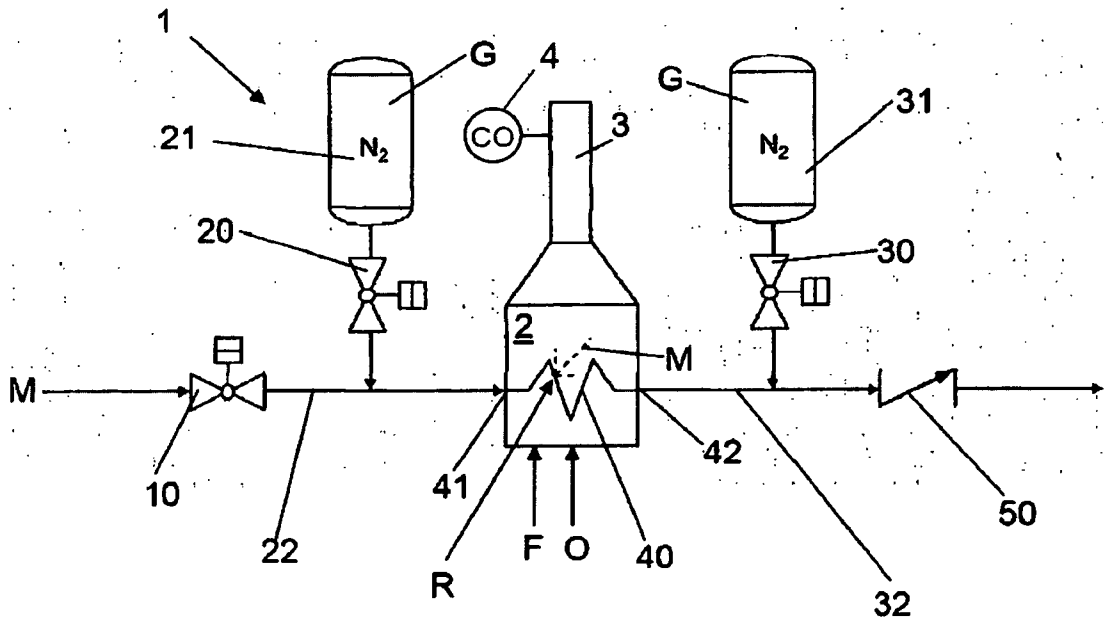

Figure 2

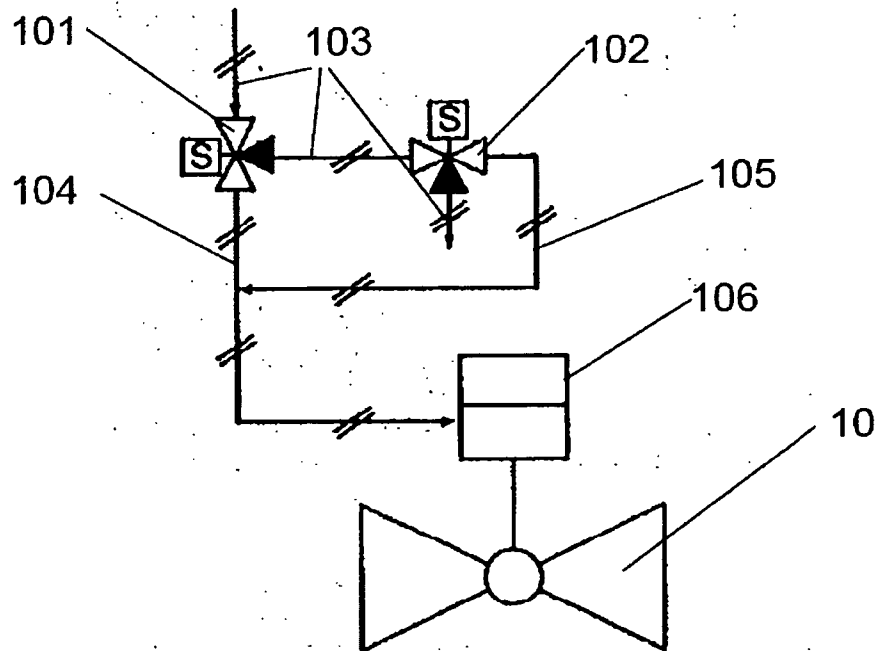

Figure 3

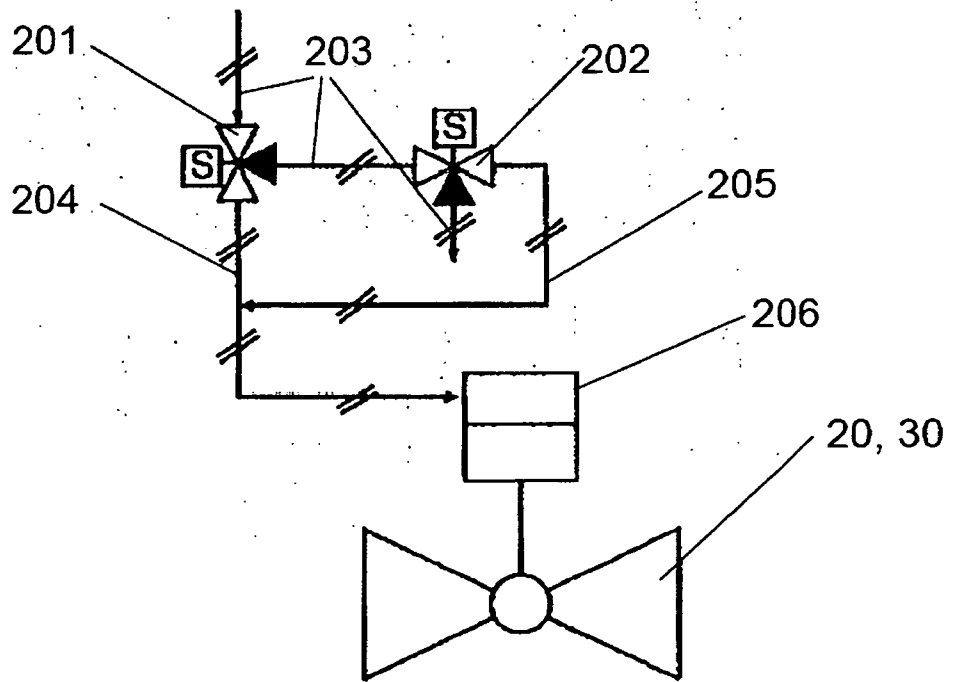

Figure 4

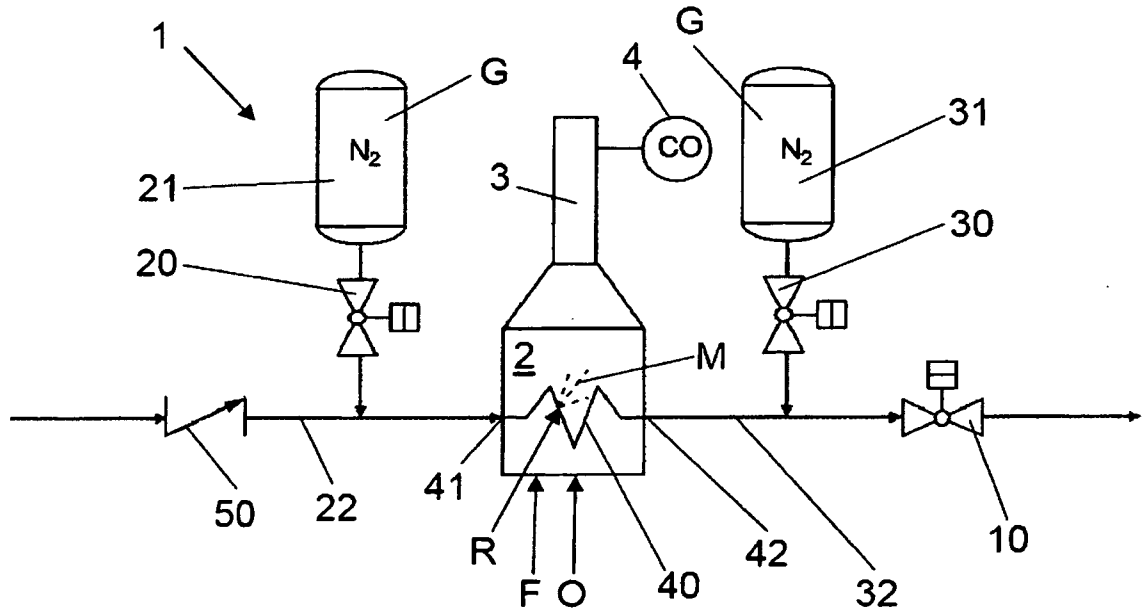
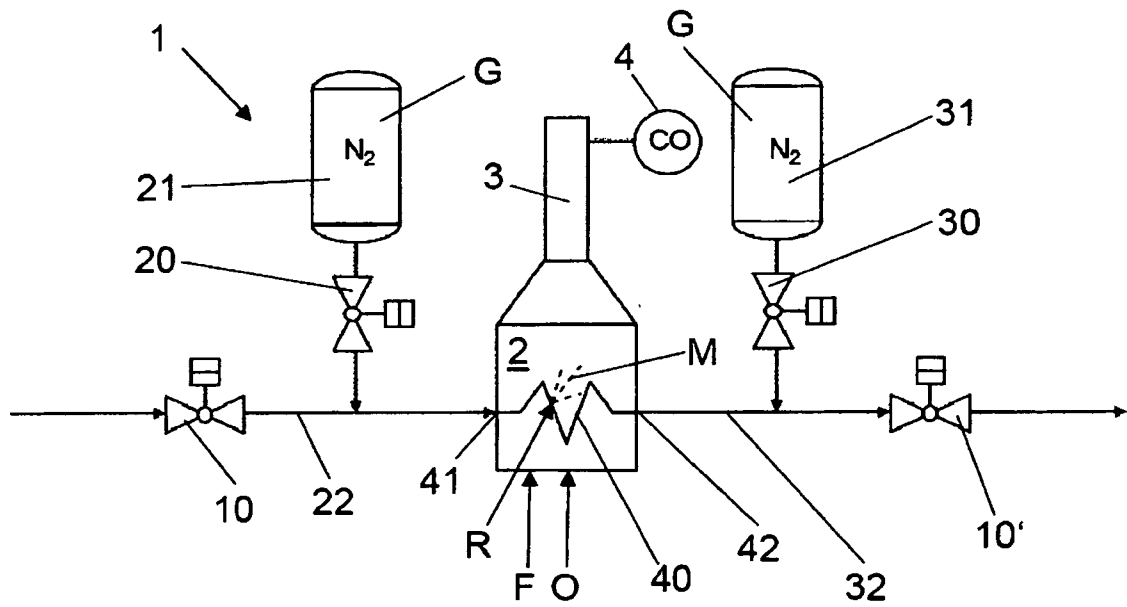

Figure 5



REFERENCES CITED IN THE DESCRIPTION

This list of references cited by the applicant is for the reader's convenience only. It does not form part of the European patent document. Even though great care has been taken in compiling the references, errors or omissions cannot be excluded and the EPO disclaims all liability in this regard.

Patent documents cited in the description

- JP 07173523 B [0003]
- JP 07027483 B [0003]

ELJÁRÁS NYOMÁSTARTÓ EDÉNY, KÜLÖNÖSEN KEMENCETÉRBEN ELRENDEZETT CSŐSPIRÁL INERT
KÖZEGGEL TÖRTÉNŐ FELTÖLTÉSÉRE

SZABADALMI IGÉNYPONTOK

1. Eljárás nyomástartó edény (40) inert közeggel történő feltöltésére, ahol az edény kemencében (2) elrendezett csőspirál, amelynek bemenete (41) és kimenete (42) van, ahol a bemenet (41) első vezetékhez (22), a kimenet (42) második vezetékhez (32) van csatlakoztatva, és ahol hevítendő közeg (M) van áthajtva a tekercsen (40), és az eljárás a következő lépésekből áll:

- lezárjuk az első vezeték (22) első szelepét (10), amely az említett bemenet (41) előtt helyezkedik el annak érdekében, hogy leállítsuk a közeg (M) bejutását az edénybe (40),
- inert közeget (G) juttatunk az első szelep (11) után elrendezett első vezetékbe (22), valamint az említett kimenet (42) után elrendezett második vezetékbe (32) annak érdekében, hogy inert közeggel telítsük az edényt (40), és
- ahol az említett inert közeget (G) az első és második vezetékbe (22, 32) olyan nyomással sajtoljuk be, amely egyenlő az edényben (40) lévő közeg (M) nyomásával, vagy olyan nyomással, amely az edényben (40) lévő közeg (M) nyomásától kevesebb, mint 2 bar-rai tér el.

2. Az 1. igénypont szerinti eljárás, *azzal jellemezve*, hogy az első vezetékbe (22) besajtolt inert közeget (G) első nyomástartályban (21) tároljuk a besajtolás előtt, és ahol az első nyomástartály (21) az első vezetékhez (22) második szelepen (20) át van csatlakoztatva, célszerűen pneumatikus szeleppel, ahol a második szelepet (20) az inert közeg (G) az első vezetékbe (22) sajtolása érdekében kinyitjuk.

3. Az előző igénypontok bármelyike szerinti eljárás, *azzal jellemezve*, hogy a második vezetékbe (32) sajtolandó inert közeget (G) második nyomástartályban (32) tároljuk a besajtolást megelőzően, ahol a második nyomástartály (32) a második vezetékhez (32) harmadik szelepen (30), célszerűen pneumatikus szelepen át van csatlakoztatva van, és ahol a harmadik szelep (30) az inert közeg (G) második vezetékbe (32) sajtolása érdekében kinyitjuk.

4. A 2. és 3. igénypontok szerinti eljárás, *azzal jellemezve*, hogy a második és a harmadik szelepek (20, 30) egyszerre vannak nyitva.

5. A 2. – 4. igénypontok bármelyike szerinti eljárás, *azzal jellemezve*, hogy az első szelepet (10) a második szelep (20) és/vagy a harmadik szelep (30) nyitása előtt lezárjuk, ahol célszerűen második vezetéken (32) negyedik szelepet (10') rendezünk el az említett kimenet (42) után, valamint az inert közegnek (G) második vezetékbe (32) történő besajtolásának helye után, és a negyedik szelepet (10') a második szelep (20) és/vagy a harmadik szelep (30) nyitása előtt lezárjuk.

6. Az előző igénypontok bármelyike szerinti eljárás, *azzal jellemezve*, hogy a folyékony közeg (M) éghető.

7. Az előző igénypontok bármelyike szerinti eljárás, *azzal jellemezve*, hogy a folyékony közeg (M) szénhidrogén.

8. Az előző igénypontok bármelyike szerinti eljárás, *azzal jellemezve*, hogy az első szelep (10) lezárásának, és különösen az említett negyedik szelep (10') lezárását, valamint az inert közeg (G) besajtolását akkor végezzük, amikor szivárgást (R) érzékelünk az edényen (40).

9. A 8. igénypont szerinti eljárás, *azzal jellemezve*, hogy az inert közeget (G) az első és második vezetékbe (22, 32) úgy sajtoljuk be, hogy a folyékony közeget (M) a edényből (40) a szivárgáson (R) át kiszorítjuk.

10. Az előző igénypontok bármelyike szerinti eljárás, *azzal jellemezve*, hogy tüzelőanyagot (F) tüzelünk a kemencében (2) annak érdekében, hogy az edényen (40) átfolyó folyékony közeget (M) hevítsük.

11. Az előző igénypontok bármelyike szerinti eljárás, *azzal jellemezve*, hogy az inert közeg (G) inert gáz, célszerűen nitrogén.

12. Az előző igénypontok bármelyike szerinti eljárás, *azzal jellemezve*, hogy az inert közeget (G) az első és második vezetékbe (22, 32) olyan nyomáson sajtoljuk be, amely az edényben (40) áramló folyékony közeg (M) nyomásától kevesebb, mint 1 bar-ral tér el.

13. Az előző igénypontok bármelyike szerinti eljárás, *azzal jellemezve*, hogy az említett inert közeget (G) az első és második vezetékbe (22, 32) olyan nyomáson sajtoljuk be, amely az edényben (40) áramló folyékony közeg (M) nyomásától kevesebb, mint 0,5 bar-ral tér el.