

L. STERNBERG.
APPARATUS FOR OBTAINING AMMONIA.

No. 522,357.

Patented July 3, 1894.

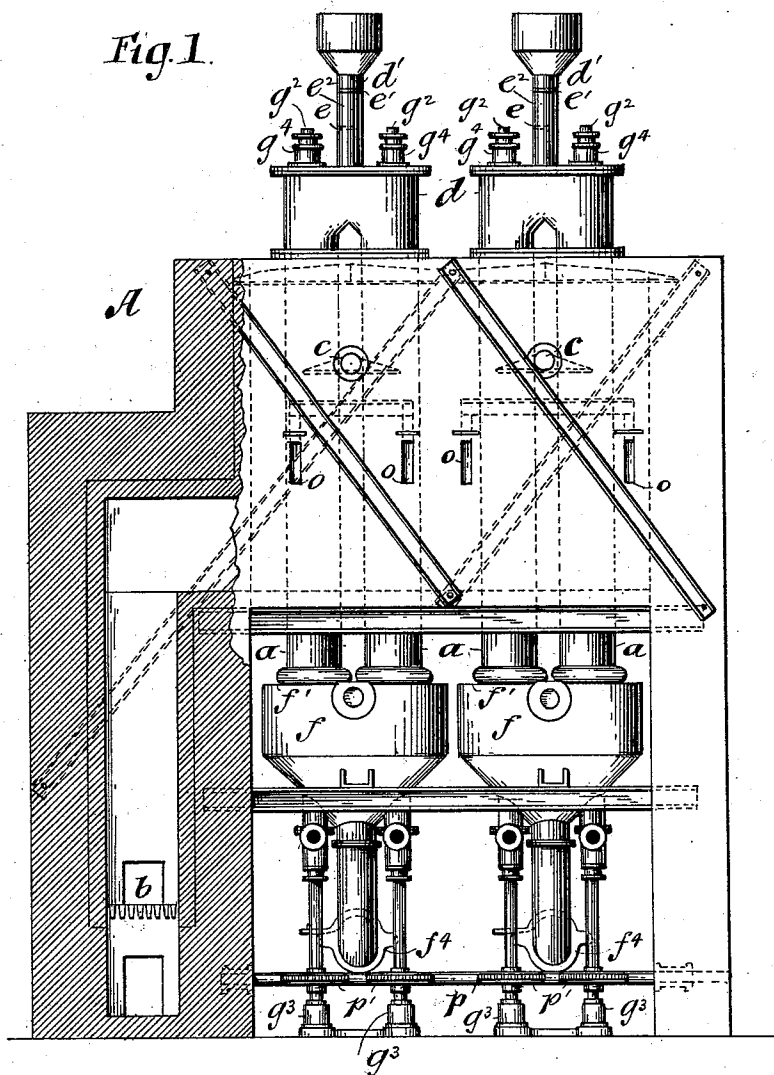

Witnesses
 Geo. Wadman
 E. Gatterer.

Inventor
 Lothar Sternberg
 Per Edw. E. Quincy,
 Atty.

(No Model.)

2 Sheets—Sheet 2.

L. STERNBERG.
APPARATUS FOR OBTAINING AMMONIA.

No. 522,357.

Patented July 3, 1894.

Fig. 2.

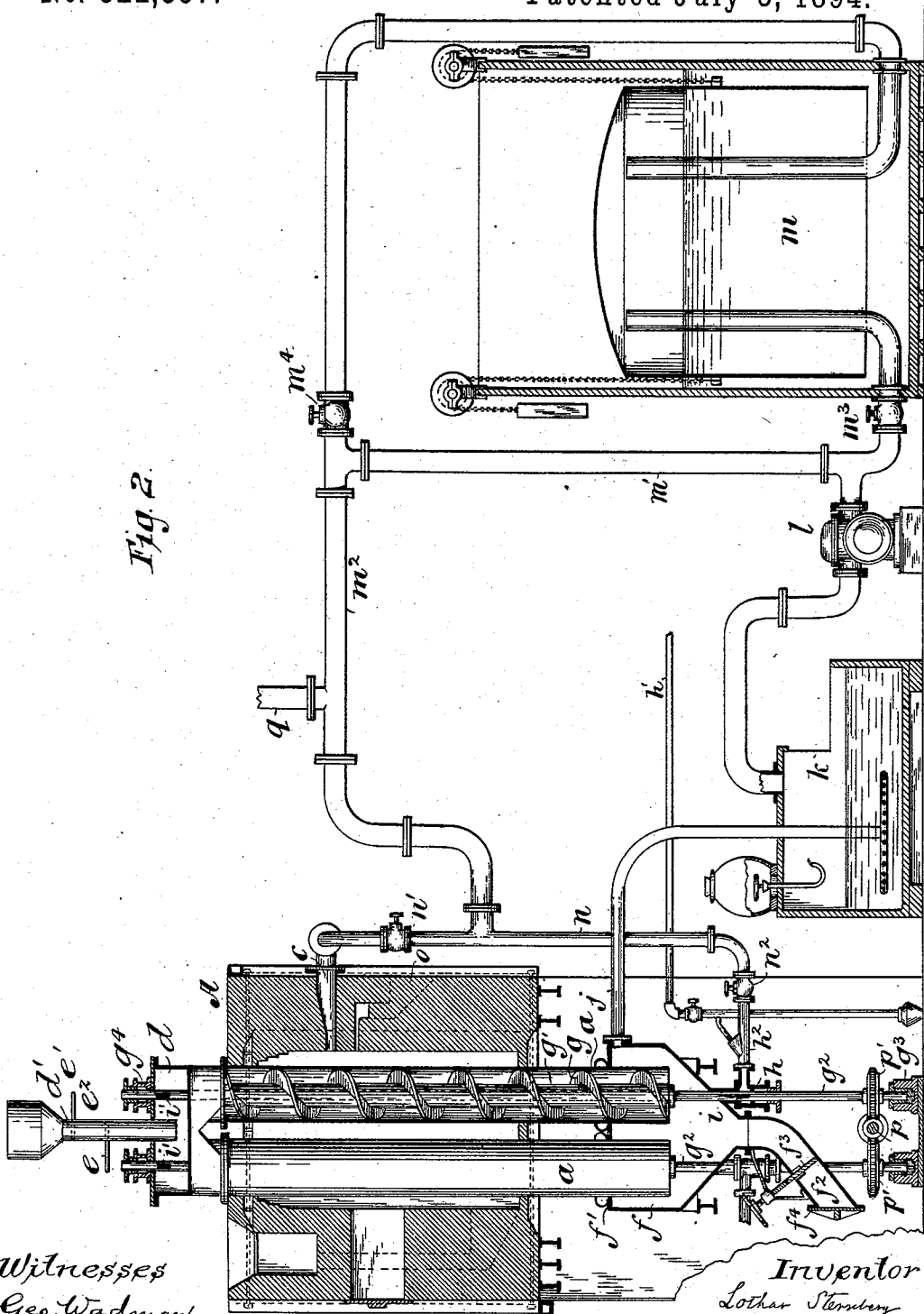

Witnesses
Geo. Wadman
E. Gatterer

Inventor
Lothar Sternberg
Per Edw. E. Lamy,
Atty.

UNITED STATES PATENT OFFICE.

LOTHAR STERNBERG, OF JERSEY CITY, NEW JERSEY.

APPARATUS FOR OBTAINING AMMONIA.

SPECIFICATION forming part of Letters Patent No. 522,357, dated July 3, 1894.

Application filed October 19, 1893. Serial No. 488,585. (No model.)

To all whom it may concern:

Be it known that I, LOTHAR STERNBERG, of Jersey City, New Jersey, have invented a certain Improvement in Apparatus for Obtaining Ammonia and Ammonia Salts from Nitrogenous Organic Matters, of which the following is a specification.

The object of this invention is to facilitate the carrying out of the process of obtaining ammonia and ammonia salts from nitrogenous organic matters described in the pending application, Serial No. 450,760, for Letters Patent of the United States therefor.

The improvement is embodied in the apparatus which is illustrated in the following drawings:

Figure 1 is an end elevation, partly in section. Fig. 2 is a longitudinal vertical section.

The drawings represent the furnace, A, containing eight vertical retorts, *a*, arranged in groups of four. The number of retorts, however, and their sizes may be varied as required.

The furnace may be heated either by fire upon the grate, *b*, or by the combustion of gas introduced through the inlet, *c*. In operation the supply of gas produced by the process may be sufficient for heating the retorts, but at the commencement of the operation, if no gas from any source is available, heat may be obtained from the fire upon the grate.

Preferably four retorts are associated in one group. Each group has at the top a common feed chamber, *d*, into which is inserted the feed pipe, *d'*, provided with the two slide valves, *e* and *e'*. The space between the slide valves, *e* and *e'*, constitutes the charge chamber, *e²*. This arrangement permits fresh charges of material to be from time to time introduced without allowing the outside air to come into contact with the glowing mass within the retorts.

The lower ends of the retorts extend a suitable distance into the common receiving chamber, *f*, closed at the top *f'*, and communicating at the bottom with the discharge chamber *f²*, from which it is separated by the adjustable slide valve *f³*, the lower extremity of the discharge chamber being provided with the door, *f⁴*. By closing the valve, *f³*, and opening the door, *f⁴*, the material contained

in the discharge chamber is discharged without allowing outside air to have access to the interior of the receiving chamber.

If a fluid organic matter is to be treated it must, previous to its introduction into the retort, be transferred into a solid porous body in the manner practiced in obtaining ammonia and other salts present in molasses, as described in Letters Patent of the United States, No. 486,647.

Each retort is provided with a vertical screw of coarse pitch, the thread, *g*, of which winds spirally around and is affixed to the elongated drum, *g'*, mounted upon the hollow shaft, *g²*, which is stepped at its lower end in the bearing, *g³*, and has its uppermost bearing in the stuffing box *g⁴*, having also an intermediate bearing in the hollow stuffing box, *h*. The portion of the hollow shaft, *g²*, contained within the hollow stuffing box, *h*, is provided with the perforation, *i*. Non-oxidizing gases mixed with steam supplied if necessary from the steam pipe, *h'*, are fed by the pipe, *h²*, into the hollow stuffing box, *h*, and thence into the hollow shaft, *g²*, through the perforation, *i*, and are discharged therefrom near the upper end of the shaft through the perforation, *i'*, into the chamber at the upper end of the retort. The steam and non-oxidizing gases thus introduced are superheated within the shaft, and to some extent cool the shaft and preserve the screw from being destroyed by the heat within the retort.

The gases and vapors issue from the lower ends of the retorts into the receiving chamber, *f*, from the upper part of which they are led by the pipe, *j*, into the absorber, *k*, of common construction, wherein by contact with sulfuric acid the ammonia is absorbed and transformed into sulfate of ammonia.

The gases, freed from the ammonia, are drawn from the upper part of the absorber by means of a gas pump, *l*, and by which they are driven either into the gasometer, *m*, or through the branch pipe, *m'*, directly into the gas service pipe, *m²*, in which latter case the valves, *m³* and *m⁴*, will be closed. When the gas is in excess the valve, *m³*, will be kept open so that the gas will be delivered into the gasometer and by opening the valve, *m⁴*, the

gas will be forced from the gasometer into the gas service pipe, m^2 .

From the gas service pipe the gas is delivered to a system of distributing pipes, one of which, n , is shown in Fig. 2. Each distributing pipe is provided near the top with a valve, n' , by opening which the gas is allowed to flow into the gas inlet c , from which it is discharged into the furnace, wherein it is used to heat the retort by being burned with air which is introduced into the furnace through the adjacent air inlet o . At its lower end the distributing pipe, n , is provided with a valve, n^2 , by which it is connected with the pipe, h^2 , by means of which it is conducted into the hollow stuffing box, h , as already mentioned.

In operation the retorts are at first filled with the material which is to be treated, which material is introduced through the feed pipe, d' , and falls through the retorts into the receiving chamber, f , which it only partially fills, because the top of the receiving chamber is, as will be seen, above the lower ends of the retorts. A fire is then started upon the grate, b , and after the retorts have become heated and gas has been formed it is introduced into the furnace chamber through the gas inlet c , and there burned as described for the purpose of keeping up the heat. Rotatory motion is imparted to the vertical screws in the retorts from the worm shaft, p , which is adapted to engage the worm wheels p' , affixed to the lower ends of the hollow shaft, g^2 , respectively. By the rotation of the screws the material contained within the retorts is kept from packing tightly and is so loosened that the gases introduced into and generated in the retort can easily penetrate and make their way through the incandescent mass of material contained in the retort. As the operation progresses and occasion arises for the removal of material from the receiving chamber, the slide valve, f^3 , is opened and the material is allowed to fall into and fill the discharge chamber, f^2 , after which the valve, f^3 , is closed and the door, f^4 , of the discharge chamber is opened. Quantities of material approximating in bulk to the bulk of the discharged material are introduced at the top, as described, by successively filling and emptying the charge chamber e^2 .

As already explained, the gas delivered from the gas pump can be driven directly into the gas service pipe, m^2 , without being made to pass through the gasometer, which is only required for use when the gas is in excess and occasion arises for temporarily storing such excess of gas. The gas service pipe, m^2 , is provided with a branch, g , by means of which, if desired, the gas or any portion thereof may be conducted off for some other purpose in any case wherein it is not desired to introduce it into the retorts or to burn it in the furnace.

What is claimed as the invention is—

1. In a system of vertical retorts arranged in groups, the combination as herein set forth of a group of vertical retorts contained within a suitable furnace chamber, means for charging said retorts without exposing their contents to direct contact with the outside air, a receiving chamber into which the lower ends of said retorts project, a discharge chamber, a movable door for opening and closing the outlet from said discharge chamber, a valve for opening and closing communication from said receiving chamber to said discharge chamber, vertical screws contained within the said retorts respectively, means for rotating said screws, a gas discharge pipe leading from the upper part of said receiving chamber, an absorber of the usual construction into which said gas discharge pipe leads, and gas pump for pumping gas from said absorber.

2. The combination, as herein set forth, of a vertical retort, a feed chamber at the top of said retort, a receiving chamber into which the lower end of said retort extends a prescribed distance, a screw within said retort, a hollow vertical shaft upon which said screw is mounted, means for rotating said hollow shaft, a hollow stuffing box affording one of the bearings for said shaft, said hollow shaft having a perforation connecting its interior with said feed chamber and also a perforation connecting its interior with said hollow stuffing box, a gas pipe communicating with said hollow stuffing box, a steam supply pipe connected with said gas pipe, an absorber, a gas pump and suitable pipe connections for drawing off the gas from said receiving chamber and forcing it mixed with steam into said hollow stuffing box, thence through said hollow shaft into said feed chamber and therefrom into said retort.

3. The combination, as herein set forth, of a furnace provided with a gas inlet and an air inlet, a group of vertical retorts contained within said furnace, a feed chamber at the top of said retorts, a receiving chamber into which the lower ends of said retorts project a prescribed distance, each of said retorts being provided with a screw mounted upon a hollow vertical shaft, means for rotating said hollow shafts and the screws mounted thereon, an absorber and a gas pump and suitable pipe connections and valves for withdrawing gas from said receiving chamber and forcing any desired portion of said gas into said furnace chamber for the purpose of burning it therein and also forcing any desired portion of said gas into a pipe communicating with said hollow shafts and with a steam supply pipe, whereby any desired portion of said gas mixed with steam is introduced under pressure into the upper ends of said retorts.

4. A system of vertical retorts arranged in groups contained in suitable furnace cham-

bers and provided respectively with rotating vertical screws, an absorber, a gas pump and a gasometer and suitable pipe connections and valves for withdrawing gas from receiving chambers into which the lower ends of said retorts extend and for distributing the said gas in any desired proportions to the said gasometer, to said furnace chambers for combustion therein, and to feed chambers communicating with the upper ends of said retorts.

LOTHAR STERNBERG.

Witnesses:

ABRAM JACOBSON,
E. GATTERER.