



(51) International Patent Classification:
B25B 29/02 (2006.01)

(21) International Application Number:

PCT/EP2019/025471

(22) International Filing Date:

20 December 2019 (20.12.2019)

(25) Filing Language:

English

(26) Publication Language:

English

(30) Priority Data:

1820999.9 21 December 2018 (21.12.2018) GB

(71) Applicant: CATERPILLAR ENERGY SOLUTIONS
GMBH [DE/DE]; Carl-Benz-Str. 1, 68167 Mannheim
(DE).

(72) Inventor: GUIASOLA, Inigo; Caterpillar Energy Solu-
tions GmbH, Carl-Benz-Str. 1, 68167 Mannheim (DE).

(74) Agent: BRP RENAUD UND PARTNER MBB; Recht-
sanwälte Patentanwälte Steuerberater, Uwe, Bernhard,
Königstraße 28, 70173 Stuttgart (DE).

(81) Designated States (unless otherwise indicated, for every
kind of national protection available): AE, AG, AL, AM,
AO, AT, AU, AZ, BA, BB, BG, BH, BN, BR, BW, BY, BZ,
CA, CH, CL, CN, CO, CR, CU, CZ, DE, DJ, DK, DM, DO,
DZ, EC, EE, EG, ES, FI, GB, GD, GE, GH, GM, GT, HN,
HR, HU, ID, IL, IN, IR, IS, JO, JP, KE, KG, KH, KN, KP,
KR, KW, KZ, LA, LC, LK, LR, LS, LU, LY, MA, MD, ME,
MG, MK, MN, MW, MX, MY, MZ, NA, NG, NI, NO, NZ,
OM, PA, PE, PG, PH, PL, PT, QA, RO, RS, RU, RW, SA,
SC, SD, SE, SG, SK, SL, SM, ST, SV, SY, TH, TJ, TM, TN,
TR, TT, TZ, UA, UG, US, UZ, VC, VN, ZA, ZM, ZW.

(84) Designated States (unless otherwise indicated, for every
kind of regional protection available): ARIPO (BW, GH,
GM, KE, LR, LS, MW, MZ, NA, RW, SD, SL, ST, SZ, TZ,
UG, ZM, ZW), Eurasian (AM, AZ, BY, KG, KZ, RU, TJ,
TM), European (AL, AT, BE, BG, CH, CY, CZ, DE, DK,

(54) Title: SYSTEM FOR TENSIONING AT LEAST ONE CONNECTING ELEMENT

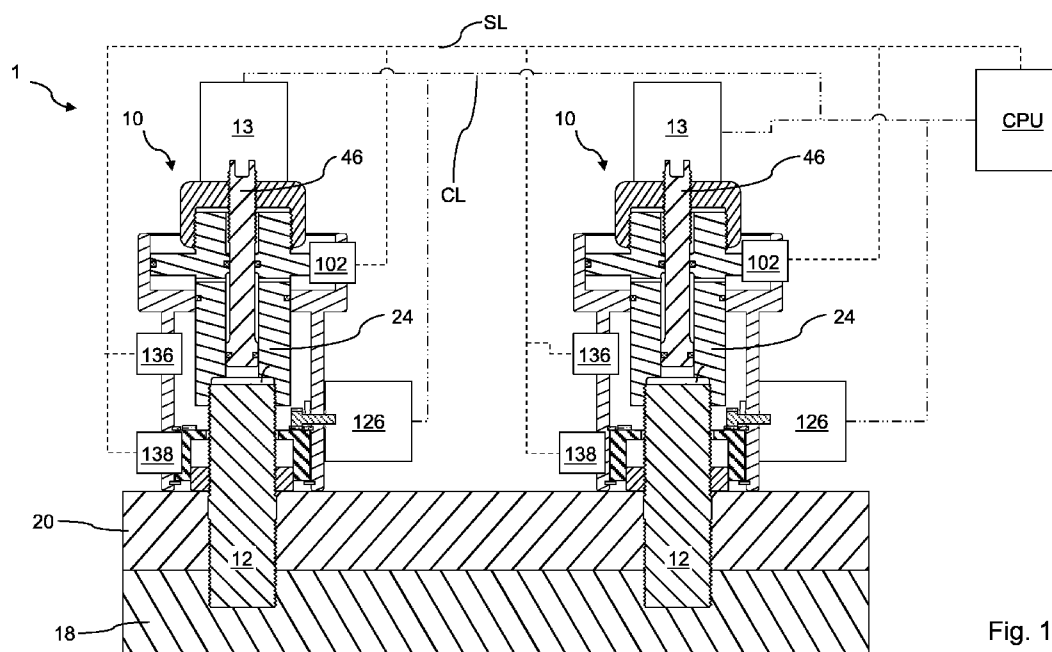

Fig. 1

(57) Abstract: The present invention refers to system (1) for tensioning at least one connecting element (12) fastened to a component (18, 20) to be tightened. The system (1) comprises at least one connecting element tensioning device (10) having an engagement element (24) connectable to the connecting element (12), and an actuating unit (44) for translating a rotational movement applied to an actuating element (46) into a translational movement of the engagement element (24) relative to the component (18, 20); at least one electric actuator (13) for rotationally actuating the actuating element (46); and a control unit (CPET) for actuating the at least one electric actuator (13).



EE, ES, FI, FR, GB, GR, HR, HU, IE, IS, IT, LT, LU, LV,
MC, MK, MT, NL, NO, PL, PT, RO, RS, SE, SI, SK, SM,
TR), OAPI (BF, BJ, CF, CG, CI, CM, GA, GN, GQ, GW,
KM, ML, MR, NE, SN, TD, TG).

Published:

- *with international search report (Art. 21(3))*
- *before the expiration of the time limit for amending the claims and to be republished in the event of receipt of amendments (Rule 48.2(h))*

(88) Date of publication of the international search report:

30 July 2020 (30.07.2020)

INTERNATIONAL SEARCH REPORT

International application No
PCT/EP2019/025471

A. CLASSIFICATION OF SUBJECT MATTER
INV. B25B29/02
ADD.

According to International Patent Classification (IPC) or to both national classification and IPC

B. FIELDS SEARCHED
Minimum documentation searched (classification system followed by classification symbols)
B25B

Documentation searched other than minimum documentation to the extent that such documents are included in the fields searched

Electronic data base consulted during the international search (name of data base and, where practicable, search terms used)
EPO-Internal, WPI Data

C. DOCUMENTS CONSIDERED TO BE RELEVANT

Category*	Citation of document, with indication, where appropriate, of the relevant passages	Relevant to claim No.
X	WO 2017/016654 A1 (CATERPILLAR ENERGY SOLUTIONS GMBH [DE]) 2 February 2017 (2017-02-02)	1,4-7
Y	paragraph [0026]; figure 1 paragraph [0035]	9,10
X	----- US 4 047 456 A (SCHOLZ MANFRED) 13 September 1977 (1977-09-13) figures 2,5	1,2
X	----- EP 2 289 663 A1 (HOHMANN FRANK [DE]; HOHMANN JOERG [DE]) 2 March 2011 (2011-03-02) paragraph [0021] - paragraph [0026]; figure 1	1,3,8,13
	----- -/--	

Further documents are listed in the continuation of Box C. See patent family annex.

* Special categories of cited documents :

"A" document defining the general state of the art which is not considered to be of particular relevance	"T" later document published after the international filing date or priority date and not in conflict with the application but cited to understand the principle or theory underlying the invention
"E" earlier application or patent but published on or after the international filing date	"X" document of particular relevance; the claimed invention cannot be considered novel or cannot be considered to involve an inventive step when the document is taken alone
"L" document which may throw doubts on priority claim(s) or which is cited to establish the publication date of another citation or other special reason (as specified)	"Y" document of particular relevance; the claimed invention cannot be considered to involve an inventive step when the document is combined with one or more other such documents, such combination being obvious to a person skilled in the art
"O" document referring to an oral disclosure, use, exhibition or other means	"&" document member of the same patent family
"P" document published prior to the international filing date but later than the priority date claimed	

Date of the actual completion of the international search 18 March 2020	Date of mailing of the international search report 24/06/2020
--	--

Name and mailing address of the ISA/ European Patent Office, P.B. 5818 Patentlaan 2 NL - 2280 HV Rijswijk Tel. (+31-70) 340-2040, Fax: (+31-70) 340-3016	Authorized officer Hartnack, Kai
--	---

INTERNATIONAL SEARCH REPORT

International application No
PCT/EP2019/025471

C(Continuation). DOCUMENTS CONSIDERED TO BE RELEVANT		
Category*	Citation of document, with indication, where appropriate, of the relevant passages	Relevant to claim No.
Y	US 2015/314431 A1 (HOHMANN FRANK [DE] ET AL) 5 November 2015 (2015-11-05) paragraph [0034] paragraph [0043] figure 1 -----	9,10

INTERNATIONAL SEARCH REPORT

International application No.
PCT/EP2019/025471

Box No. II Observations where certain claims were found unsearchable (Continuation of item 2 of first sheet)

This international search report has not been established in respect of certain claims under Article 17(2)(a) for the following reasons:

1. Claims Nos.:
because they relate to subject matter not required to be searched by this Authority, namely:

2. Claims Nos.:
because they relate to parts of the international application that do not comply with the prescribed requirements to such an extent that no meaningful international search can be carried out, specifically:

3. Claims Nos.:
because they are dependent claims and are not drafted in accordance with the second and third sentences of Rule 6.4(a).

Box No. III Observations where unity of invention is lacking (Continuation of item 3 of first sheet)

This International Searching Authority found multiple inventions in this international application, as follows:

see additional sheet

1. As all required additional search fees were timely paid by the applicant, this international search report covers all searchable claims.

2. As all searchable claims could be searched without effort justifying an additional fees, this Authority did not invite payment of additional fees.

3. As only some of the required additional search fees were timely paid by the applicant, this international search report covers only those claims for which fees were paid, specifically claims Nos.:

4. No required additional search fees were timely paid by the applicant. Consequently, this international search report is restricted to the invention first mentioned in the claims; it is covered by claims Nos.:

1-10, 13

Remark on Protest

- The additional search fees were accompanied by the applicant's protest and, where applicable, the payment of a protest fee.
- The additional search fees were accompanied by the applicant's protest but the applicable protest fee was not paid within the time limit specified in the invitation.
- No protest accompanied the payment of additional search fees.

FURTHER INFORMATION CONTINUED FROM PCT/ISA/ 210

This International Searching Authority found multiple (groups of) inventions in this international application, as follows:

1. claims: 1-10, 13

System for tensioning at least one connecting element fastened to a component to be tightened, comprising: at least one connecting element tensioning device having an engagement element connectable to the connecting element, and an actuating unit for translating a rotational movement applied to an actuating element into a translational movement of the engagement element relative to the component; at least one electric actuator for rotationally actuating the actuating element; and a control unit (CPU) for actuating the at least one electric actuator, characterized by controlling a tensioning process by the tensioning force / fluid pressure / engagement element position.

2. claims: 11, 12

System for tensioning at least one connecting element fastened to a component to be tightened, comprising: at least one connecting element tensioning device having an engagement element connectable to the connecting element, and an actuating unit for translating a rotational movement applied to an actuating element into a translational movement of the engagement element relative to the component; at least one electric actuator for rotationally actuating the actuating element; and a control unit (CPU) for actuating the at least one electric actuator, characterized by a screwing element connectable to a nut engaged with the connecting element and a screwing unit for rotationally actuating the screwing element relative to the connecting element, wherein the system further comprises at least one further electric actuator for actuating the screwing unit of the at least one tensioning device, and wherein the control unit (CPU) is configured to actuate the at least one further electric actuator.

3. claim: 14

System for tensioning at least one connecting element fastened to a component to be tightened, comprising: at least one connecting element tensioning device having an engagement element connectable to the connecting element, and an actuating unit for translating a rotational movement applied to an actuating element into a translational movement of the engagement element relative to the component; at least one electric actuator for rotationally actuating the actuating element; and a control unit (CPU) for actuating the at least one electric actuator,

FURTHER INFORMATION CONTINUED FROM PCT/ISA/ 210

characterized by
a torque multiplier unit interposed between the actuating
element and the electric actuator which is configured to
transform an input torque applied to a transmission input
element by means of the electric actuator into an output
torque applied to the actuating element which absolute value
is higher compared to the input torque.

INTERNATIONAL SEARCH REPORT

Information on patent family members

International application No

PCT/EP2019/025471

Patent document cited in search report	Publication date	Patent family member(s)	Publication date
WO 2017016654	A1	02-02-2017	EP 3310533 A1 25-04-2018
			US 2018215022 A1 02-08-2018
			WO 2017016654 A1 02-02-2017

US 4047456	A	13-09-1977	NONE

EP 2289663	A1	02-03-2011	DE 102009043907 A1 03-03-2011
			DK 2289663 T3 07-05-2018
			EP 2289663 A1 02-03-2011
			ES 2662324 T3 06-04-2018
			JP 5693103 B2 01-04-2015
			JP 2011051090 A 17-03-2011
			US 2011048176 A1 03-03-2011

US 2015314431	A1	05-11-2015	DE 102014106215 A1 05-11-2015
			DK 2942156 T3 12-06-2017
			EP 2942156 A2 11-11-2015
			US 2015314431 A1 05-11-2015
