

**(12) PATENT**  
**(19) AUSTRALIAN PATENT OFFICE**

**(11) Application No. AU 199729507 B2**  
**(10) Patent No. 711972**

(54) Title  
**Process for optimizing the utilization of connecting links in systems which transmit data in data packets**

(51)<sup>6</sup> International Patent Classification(s)  
**H04Q 011/04**

(21) Application No: **199729507**

(22) Application Date: **1997.05.12**

(87) WIPO No: **WO97/44985**

(30) Priority Data

(31) Number	(32) Date	(33) Country
<b>19620428</b>	<b>1996.05.21</b>	<b>DE</b>

(43) Publication Date : **1997.12.09**

(43) Publication Journal Date : **1998.02.19**

(44) Accepted Journal Date : **1999.10.28**

(71) Applicant(s)  
**Siemens Aktiengesellschaft**

(72) Inventor(s)  
**Uwe Briem**

(74) Agent/Attorney  
**SPRUSON and FERGUSON,GPO Box 3898,SYDNEY NSW 2001**

(56) Related Art  
**EP 705007**



(51) Internationale Patentklassifikation <sup>6</sup> :  
H04Q 11/04

A1

(11) Internationale Veröffentlichungsnummer: **WO 97/44985**

(43) Internationales  
Veröffentlichungsdatum: 27. November 1997 (27.11.97)

(21) Internationales Aktenzeichen: PCT/DE97/00954

(22) Internationales Anmeldedatum: 12. Mai 1997 (12.05.97)

(30) Prioritätsdaten:  
196 20 428.3 21. Mai 1996 (21.05.96) DE

(71) Anmelder (für alle Bestimmungsstaaten ausser US): SIEMENS  
AKTIENGESELLSCHAFT [DE/DE]; Wittelsbacherplatz 2,  
D-80333 München (DE).

(72) Erfinder; und  
(75) Erfinder/Anmelder (nur für US): BRIEM, Uwe [DE/DE];  
Göttlerstrasse 2, D-82216 Maisach (DE).

(81) Bestimmungsstaaten: AU, CA, JP, US, europäisches Patent  
(AT, BE, CH, DE, DK, ES, FI, FR, GB, GR, IE, IT, LU,  
MC, NL, PT, SE).

Veröffentlicht  
Mit internationalem Recherchenbericht.  
Vor Ablauf der für Änderungen der Ansprüche zugelassenen  
Frist. Veröffentlichung wird wiederholt falls Änderungen  
eintreffen.

(54) Title: PROCESS FOR OPTIMIZING THE UTILIZATION OF CONNECTING LINKS IN SYSTEMS WHICH TRANSMIT DATA IN DATA PACKETS

(54) Bezeichnung: VERFAHREN ZUR OPTIMIERUNG DER AUSLASTUNG VON VERBINDUNGSABSCHNITTEN IN SYSTEMEN, IN DENEN INFORMATIONEN IN DATENPAKETEN ÜBERTRAGEN WERDEN

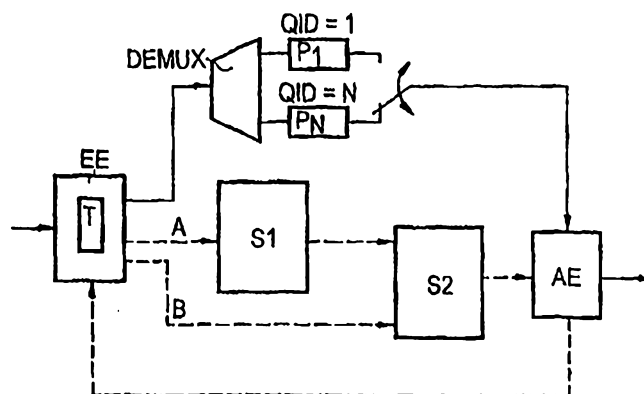

(57) Abstract

The Weighted Fair Queuing Scheduling process has established itself in prior art regarding switching of data packets. This process only ensures a lower delimitation for the transmission rate of data packets. In order to also reach an upper limit of the transmission rate, the process of this invention optionally provides for interposing an additional scheduling process.

(57) Zusammenfassung

Beim Stand der Technik hat sich zur Übertragung von Datenpaketen das Weighted Fair Queueing Scheduling-Verfahren herausgebildet. Dieses Verfahren stellt ausschließlich eine untere Begrenzung der Übertragungsrates der Datenpakete sicher. Um auch eine obere Begrenzung der Übertragungsrates erreichen zu können, wird beim erfindungsgemäßen Verfahren gegebenenfalls ein weiteres Scheduling-Verfahren vorgeschaltet.

## Abstract

Method for optimization of the utilization of connecting sections in systems in which information is transmitted in data packets.

The weighted fair queueing scheduling method has been developed in the prior art for the transmission of data packets. This method ensures only a lower limit on the transmission rate of the data packets. In order to be able to achieve an upper limit on the transmission rate as well, a further scheduling method may be used prior to this, in the method according to the invention.

Figure 1

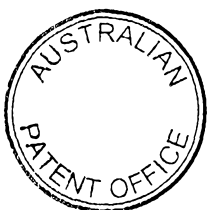

## Description

Method for optimization of the utilization of connecting sections in systems in which information is transmitted in data packets.

5           The invention relates to a method as claimed in the precharacterizing clause of patent claim 1.

          In modern packet switching systems, information is transmitted in data packets. One example of this is ATM cells. These have a header part and an information  
10       part. The header part is used to store connection information, and the information part to store the wanted data to be transmitted. As a rule, the actual transmission takes place via connecting sections between the transmitter and receiver. In this case, there may be a  
15       requirement to utilize the connecting sections in such a manner that a plurality of transmitting devices transmit the cell streams originating from these devices via the same connecting section.

          In order to allow the transmission of the respective cell streams to be carried out in accordance with  
20       the requirements of the individual cell streams, a so-called WEIGHTED FAIR QUEUEING SCHEDULING method has become generally accepted in the prior art. The corresponding relationships are described, for example, in the  
25       document "Virtual Spacing for Flexible Traffic Control", J.W. Roberts, International Journal of Communication Systems, Vol. 7, 307-318 (1994). In this case, the individual cell streams are assigned different weighting factors, which are used to control the actual transmission process on the individual connecting sections.  
30       Reference should be made to Figure 3 to assist understanding.



By way of example, this shows cell streams 1 ...  
n. The n cell streams are passed from a transmitting  
device DEMUX in the direction of one or more receivers.  
In practice, only one common connecting section is used  
5 in this case. The n cell streams are furthermore assigned  
weighting factors  $r_1 \dots r_n$ . To assist understanding, it  
is assumed that it is intended to pass only two cell  
streams, namely the cell streams 1, 2, via a connecting  
section. The connecting section is furthermore intended  
10 to have a maximum transmission capacity of 150 Mbit/s.  
The two cell streams 1 and 2 are assigned weightings  $r_1 =$   
2 and  $r_2 = 1$ . This results in the cell stream 1 being  
transmitted at a transmission rate of 100 Mbit/s, and the  
cell stream 2 at only 50 Mbit/s, if cells for both cell  
15 streams are present for transmission. If only one of the  
two cell streams has cells to transmit, this cell stream  
is assigned the total transmission capacity of  
150 Mbit/s.

Figure 2 shows how the theoretical considerations  
20 addressed above are implemented in practice in the prior  
art. This shows how data packets, or ATM cells, are dealt  
with using the weighted fair queueing scheduling  
algorithm. In this case, incoming cells are supplied to  
the input device EE, are passed on to the demultiplexing  
25 device DEMUX and are stored there with the aid of a  
demultiplexing function, which is implemented here, and  
with the assistance of an identifier QID in a logic  
queue. The identifier QID is in this case contained in  
the cell header of each cell.

30 At the same time, control data which are deter-  
mined in the input device EE are for this purpose  
supplied to a scheduler device S. A scheduling algorithm  
which is known per se is executed in this device.

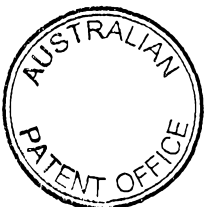

This may be, for example, the weighted fair queueing scheduling algorithm or any other algorithm. This algorithm determines, for example, the sequence in which or the time at which it is intended to read the cells which are stored in the buffer stores P1...Pn. The result of the assessment of the control data by this algorithm is supplied to the output device AE. The cells stored in the buffer stores P1...Pn are now read, on the basis of the result of the assessment, by the algorithm which is being executed in the scheduling device S. Furthermore, an acknowledgement signal is fed back to the input device EE. After this and when a new cell with an identifier QID arrives in the input device EE and when an acknowledgement 'selected QID' is present, the input device EE uses the buffer filling level for QID = i as well as the scheduling method to decide whether the message "SCHEDULE QID" is generated. This message indicates to the scheduler device S that it should carry out initial planning for the next transmission time for this identifier QID, in some way.

A problematic feature of such a procedure is that, although the weighted fair queueing scheduling algorithm guarantees minimum cell rates, a maximum cell rate limiting cannot be carried out here. However, this is a major factor since, in practice, both minimum and maximum cell rates often have to be complied with - for example in the case of ABR (available bit rate) traffic.

The invention is based on the object of indicating a way in which the weighted fair queueing scheduling algorithm can be modified in such a way that optimized transmission is ensured here as well.



The object is achieved on the basis of the features specified in the precharacterizing clause of patent claim 1, by means of the features in the characterizing part.

5           An advantageous feature of the invention is that a two-stage scheduling method may be carried out depending on an identifier which is contained in the packet header. In this case, the result of the first stage is used as an input signal for the second stage. This  
10 results in particular in the capability to control both a lower limit and an upper limit of the cell rate. In particular, this method is not limited to the use of a specific algorithm.

15           Further refinements of the invention are provided in the dependent claims.

          Claim 2 provides that the connection parameters are limited during the transmission process, by means of the first stage of the two-stage scheduling method. This is intended, in particular, to control limiting of the  
20 cell rate. This results in the cells not being transmitted at higher cell rates during the transmission process.

          Claim 3 provides that the second stage of the two-stage scheduling method is the weighted fair queueing  
25 scheduling algorithm. This is linked to the advantage that a proven method can be used. A further advantage of this is that this algorithm guarantees lower limiting of the cell rate.

30           Claim 4 provides for an input device to contain a table which contains the current filling levels of the buffer stores. This is linked to the advantage that a current map of these filling levels is stored here at all times.



Claim 5 provides that, depending on the control data obtained from the scheduler device, the output device takes cells from at least one of the buffer stores and acknowledges this process to the input device. As a  
5 result of the feedback, the reading process has a direct influence on the first stage of the two-stage method. The two stages of the two-stage scheduling method thus do not operate independently of one another. The way in which the first stage operates is influenced by the way in  
10 which the second stage operates. The identifier or the packet length may be used, for example, as feedback parameters.

Claim 6 provides that the identifier is entered while the connection is being set up.

15 Claim 7 provides that the data packets are ATM cells. The invention can thus be applied in particular to ATM networks.

In the figures:

Figure 1 shows the method according to the invention,

20 Figure 2 shows the practical application of the prior art,

Figure 3 shows theoretical considerations relating to the prior art.

25 Figure 1 shows the method according to the invention. In this case, it is assumed that the information is transmitted in ATM cells, using an asynchronous transfer method (ATM).

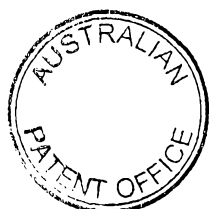

The cells are supplied to the input device EE in a cell stream. The routing information is stored in the header part of each cell. Furthermore, an identifier QID has been stored here while the connection is being set up. This identifier is a cell stream identifier which is entered in the cell header on a connection-specific basis or for a group of connections. As a rule, the identifier QID is assigned simple numerical values. In the present exemplary embodiment, the identifier QID is intended to have the values 1...N. Originating from the input device EE, the cells themselves are supplied to the demultiplexing device DEMUX where they are written into buffer stores P1...Pn, designed as a logic queue, with the aid of a demultiplexing function, which is implemented here, and with the assistance of the identifier QID.

The input device EE furthermore contains a table T as to which of the connections require the connection parameters to be limited during the transmission process. In the present exemplary embodiment, it is assumed that limiting of the cell rate is controlled in the sense of limiting the connection parameters. In order to verify the connection, the identifier QID is taken from each of the incoming cells and is compared with the entries in the table T.

If it is not intended to limit the cell rate for a connection, corresponding control data are supplied via the connecting section B to the scheduler device S<sub>2</sub>, bypassing the scheduler device S<sub>1</sub>. There, the control data are used in a scheduling algorithm which is known per se. In the present exemplary embodiment, this is intended to be weighted fair queueing scheduling method, which has already been described in the introduction. Such an algorithm results in a lower cell rate being guaranteed, in the sense of guaranteeing the connection parameters of the cells during the transmission process.



According to the present exemplary embodiment, the cell rate for one of the connections is limited, for example for the connection with the number 8 (QID=8). In this case, the control data are supplied via the connecting section A to the scheduler device  $S_1$ . Here, an algorithm starts to be executed, which controls an upper limit on the cell rate. This is done by a function implemented here using the identifier QID for initial planning of the control data supplied from the input device EE, such that the individual cells do not exceed a predetermined rate. At the time at which the scheduler device  $S_1$  would read a cell, it produces, however, a control signal itself for initial planning of the read time, corresponding to the general scheduling algorithm being executed in the scheduler device  $S_2$ . No initial planning of the next event takes place in the scheduler device  $S_1$  for the same identifier QID. Thus, stimulated by the scheduler device  $S_1$ , the scheduler device  $S_2$  plans the sequence for the indicated identifier QID, corresponding to the scheduling algorithm being executed here. The cells initially planned by the scheduler device  $S_1$  may thus experience an additional delay. The peak bit rate set in the scheduler device  $S_1$  may thus be different from that used to read the cells.

By way of example, the weighted fair queueing scheduling algorithm is intended to be used in the scheduler device  $S_2$  in the present exemplary embodiment, although other algorithms can also be used. The method according to the invention is not limited to the use of a specific algorithm.

The result of the evaluation of the algorithm being executed in the scheduler device  $S_2$  is passed to the output device AE.

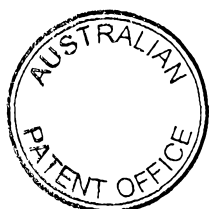

Whenever it is intended to read the next cell from a buffer store  $P_1 \dots P_n$  with a specific identifier QID, this is indicated to the output device AE. This reads the first cell with the indicated identifier QID from the  
5 buffer store  $P_1 \dots P_n$  in question, and reports this together with the corresponding identifier QID to the input device EE. The latter then checks whether a further cell with this QID is stored in the buffer store. If this is the case, a corresponding signal (SCHEDULE QID) is  
10 sent to the scheduler device  $S_1$ . If this is not the case, no further action takes place in the sense of initial planning (reading) in the scheduler device  $S_1$  for this identifier QID.

This method means that an event for an identifier  
15 QID can be initially planned only in the scheduler device  $S_1$  or  $S_2$ , but not at the same time in both devices. Furthermore, the two function blocks  $S_1$  and  $S_2$  are not linked to a specific implementation. This two-stage algorithm is thus used to determine the sequence in which  
20 and the time at which it is intended to read the cells which are stored in the buffer stores  $P_1 \dots P_n$ .

Finally, it should also be mentioned that the above exemplary embodiment has been described using the example of ATM cells. However, the invention is not just  
25 limited to this. The method according to the invention can likewise be used for the transmission of information in data packets as such. However, in this case it is necessary to ensure that the packet length is added to the control data.

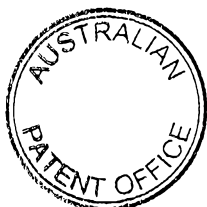

## Patent Claims

1. A method for optimization of the utilization of connecting sections in systems in which information is transmitted in data packets, having
- 5 a scheduling method ( $S_2$ ) by means of which connection parameters, which are representative of lower transmission rates of the data packets, are guaranteed during the transmission process, and having
- 10 a queue identifier (QID) which is stored in the packet header, characterized
- in that a further scheduling method ( $S_1$ ) may precede the scheduling method ( $S_2$ ) depending on the queue identifier (QID), by means of which further scheduling method ( $S_1$ )
- 15 the connection parameters which are representative of upper transmission rates of the data packets are limited during the transmission process.
2. The method as claimed in claim 1, characterized
- 20 in that the scheduling method ( $S_2$ ) is a weighted fair queueing scheduling algorithm.
3. The method as claimed in claim 1 or 2, characterized
- 25 in that an input device (EE) contains a table (T) which contains the current filling levels of buffer stores ( $P_1 \dots P_n$ ).



4. The method as claimed in one of the preceding claims,  
characterized  
in that, depending on the control data which are obtained  
5 from the scheduling method ( $S_2$ ), an output device (AE)  
takes data packets from at least one of the buffer stores  
( $P_1 \dots P_n$ ) and acknowledges this process to the input  
device (EE).

10 5. The method as claimed in one of the preceding  
claims,  
characterized  
in that the queue identifier (QID) is entered while the  
connection is being set up.

15 6. The method as claimed in one of the preceding  
claims,  
characterized  
in that the data packets are ATM cells.

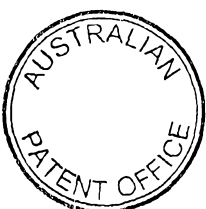

7. A method for optimisation of the utilisation of connecting sections in systems in which information is transmitted in data packets, substantially as described herein with reference to Fig. 1.

5

DATED this Twenty-fifth Day of November 1998

**Siemens Aktiengesellschaft**

Patent Attorneys for the Applicant

SPRUSON & FERGUSON

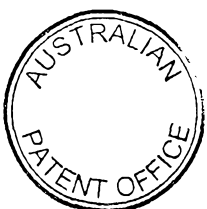
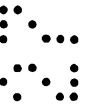
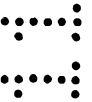
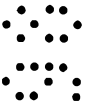
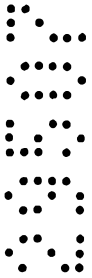

FIG 1

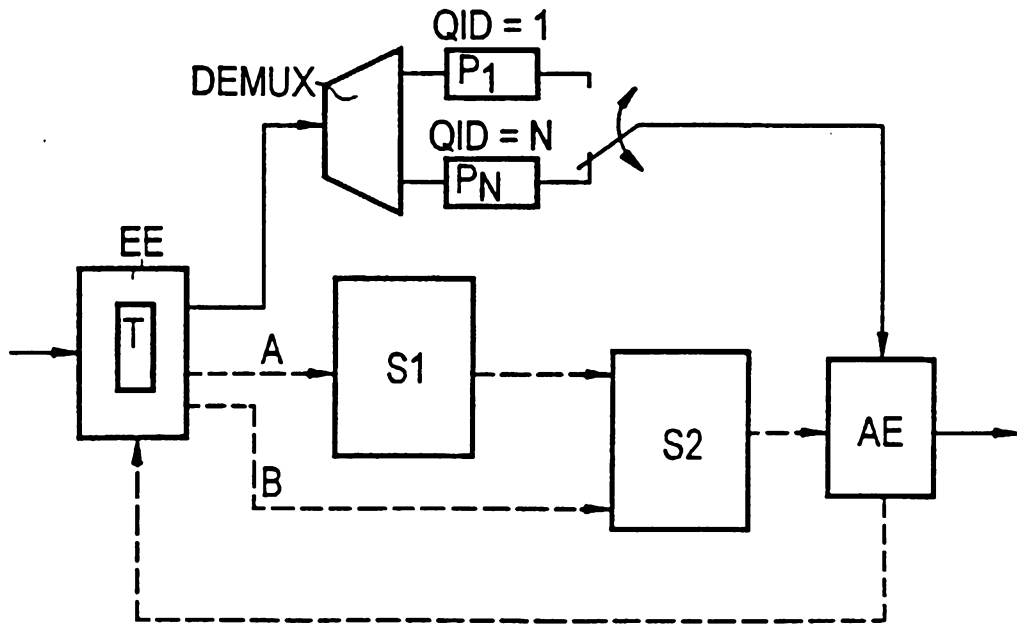

FIG 2

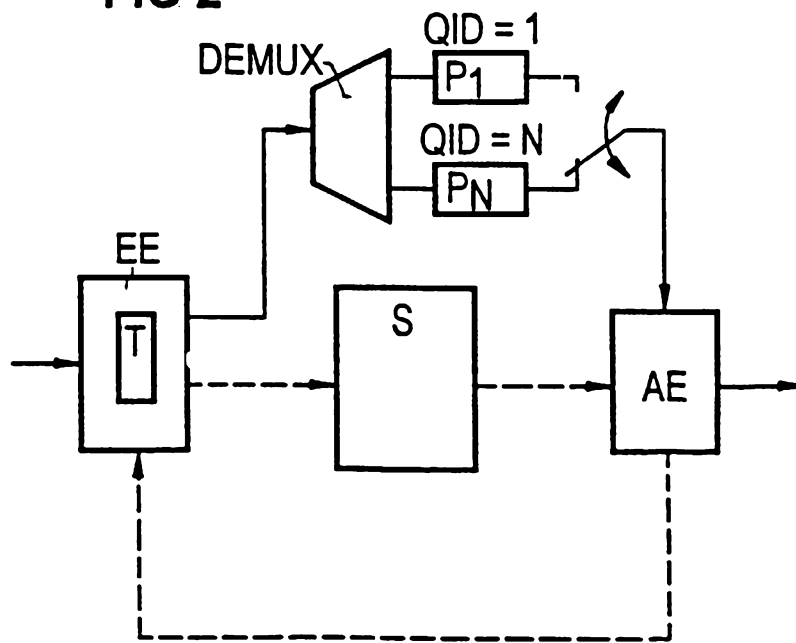

FIG 3

