

C. DOWNER.
Dumping-Wagon.

No. 6,609.

Patented July 24, 1849.

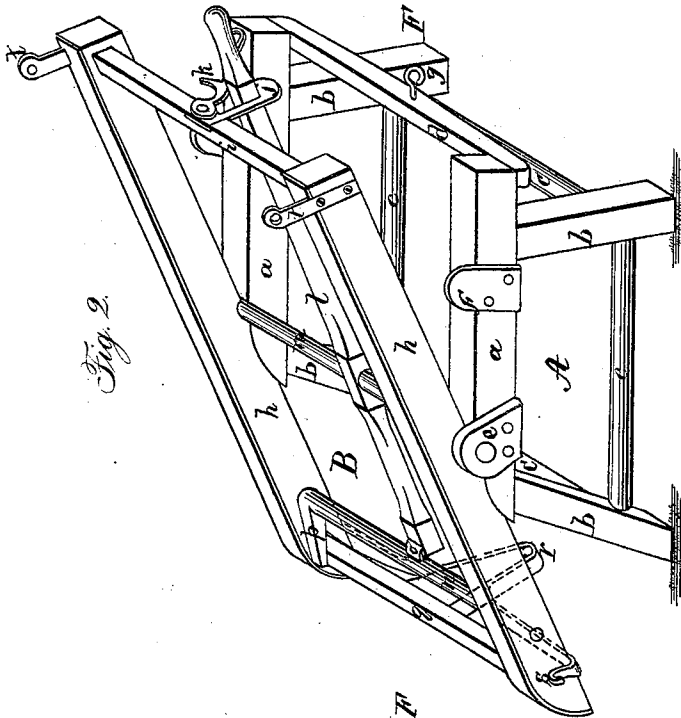

Fig. 2.

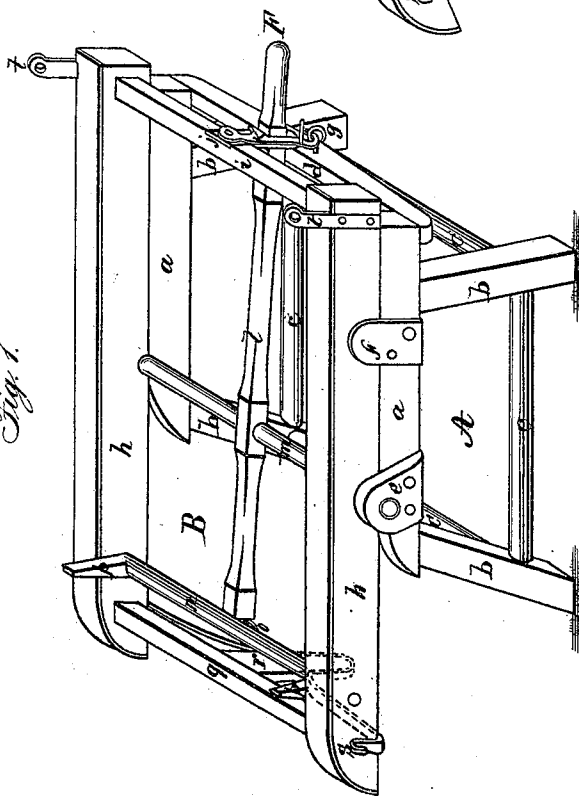

Fig. 1.

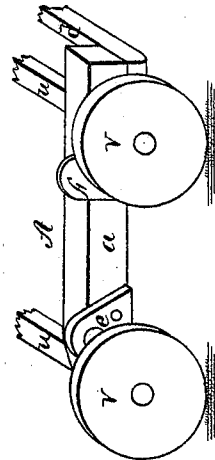

Fig. 3.

UNITED STATES PATENT OFFICE.

CHARLES DOWNER, OF PHILADELPHIA, PENNSYLVANIA.

APPARATUS FOR UNLOADING CARTS, &c.

Specification of Letters Patent No. 6,609, dated July 24, 1849.

To all whom it may concern:

Be it known that I, CHARLES DOWNER, of the city and county of Philadelphia, in the State of Pennsylvania, have invented a new and useful Unloading Apparatus for Weighing and other Purposes; and I do hereby declare that the following is a full, clear, and exact description of the construction and operation of the same, reference being had to the annexed drawings, making a part of this specification, in which—

Figure 1 represents a complete apparatus with the tilting-frame in a horizontal position, or at rest; Fig. 2, the same, with the tilting-frame in its inclined position, or during the act of tilting; and Fig. 3 shows the manner of applying wheels to said apparatus when requisite.

The apparatus, represented in the drawing, is one to be used for weighing short articles, such as pig-iron and other similar ones, which allow of being tilted off (promiscuously) without injury to them. It is composed of two main parts, viz: the lower or stationary frame A, and the upper or tilting frame B. The former consists of two parallel top rails *a*, the supporters or legs *b*, the cross-ties *c*, and *d*, the gudgeon boxes *e*, the guides *f*, and the eye or staple *g*. The upper or tilting frame is composed of the parallel side rails *h*, the front cross rails *i*, the lever-guide *j*, the hook or check *k*, the central lever *l*, its fulcrum or axis *m*, the stanchion rod *n* with its cam *o*, the movable stanchions *p*, the rear cross rail *q* and its standard *r*, the hooks *s*, and the front permanent stanchions *t*. All the parts appertaining to the apparatus having thus been enumerated, the following is a description of its operation. The apparatus is placed crosswise under the common weighing frame, the front end F toward the pile of articles to be weighed. The upper or tilting-frame B rests in a horizontal position on the lower frame A (see Fig. 1), and is secured thereto by means of the hook *k* being inserted in the eye or staple *g* on the cross-tie *d*. The movable stanchions *p* are kept in an upright position by means of the cam *o* on the bar *n*, which former presses against the rear-end of the central lever *l*, the front end whereof is held down by means of the check *k*. The tilting frame is loaded with the articles to be weighed, the chains of the weighing-frame are at-

tached to the hooks *s* and the stanchions *t*, and the weight is taken. This being accomplished, the hook and check *k* is swung over, disengaging the tilting-frame from the lower one and relieving the front end of the central lever *l*. Said end of the lever is then raised (by hand) whereby the opposite end thereof is depressed, clearing the cam *o*, and consequently allowing the stanchions *p* to lay down, when pressed against by the articles, and make room for the whole load to slide off; the tilting-frame being so balanced on the gudgeons *e*, as to tilt nearly of its own accord and with but little assistance, which is rendered by slightly raising the said front end of the central lever. The standard *r* serves to support the rear-end of the tilting-frame, when tilted. Said tilted position is distinctly shown in Fig. 2.

When articles, such as scrap iron, &c., (too small to be weighed in the above-described manner), are to be weighed, the tilting frame is furnished with a temporary bottom supported by flanges on the inside of the side-rails *h*, or in any other suitable manner. Suitable upright end and side boards are also made use of, when requisite.

For the weighing of bar-iron and other similar long articles, the apparatus requires to be shorter and wider than the one described above, otherwise alike in construction and operation. In this case, the weighing-frame is placed lengthwise over the apparatus after being loaded, and when the weight has been taken, the weighing-frame is removed sideways a sufficient distance to allow the articles to be tilted off; and when loaded again the said frame is placed over the apparatus again in the same manner.

The lower frame A instead of being supported by legs *b*, may rest on axletrees *u* and wheels *v*, as represented in Fig. 3, to be used when articles require to be removed a greater or less distance, either to or from the weighing-frame or platform scale, or from one place to another, without being weighed.

What I claim as my invention, and desire to secure by Letters Patent, is:

1. The combination of the upper or tilting-frame B with the lower frame A, the latter being either stationary or on wheels.
2. I furthermore claim the central lever *l* with its check and hook *k*, in combination with the stanchion-rod *n*, the cam *o*, and the

stanchions p ; and said lever, check and hook, stanchion-rod, cam, and stanchions, in combination with the tilting-frame B, being mounted either on a stationary frame, as
5 represented in Fig. 1 and 2, or on wheels as shown in Fig. 3; the construction, arrangement, and operation of all of which

being substantially in the manner and for the purposes herein above described.

CHARLES DOWNER.

Witnesses:

FRANCIS BENNE,
CHAUNCEY BULKLEY.