



(11) **EP 2 733 247 A1**

(12) **EUROPEAN PATENT APPLICATION**

(43) Date of publication:
21.05.2014 Bulletin 2014/21

(51) Int Cl.:
D06F 35/00 (2006.01)

(21) Application number: **13193069.5**

(22) Date of filing: **15.11.2013**

(84) Designated Contracting States:
AL AT BE BG CH CY CZ DE DK EE ES FI FR GB GR HR HU IE IS IT LI LT LU LV MC MK MT NL NO PL PT RO RS SE SI SK SM TR
Designated Extension States:
BA ME

(72) Inventors:
• **Mancini, Mauro**
60044 Fabriano (AN) (IT)
• **Dottori, Mariangiola**
60043 Cerreto d'Esi (AN) (IT)
• **Latini, Giuliana**
60044 Fabriano (AN) (IT)

(30) Priority: **19.11.2012 IT PR20120077**

(71) Applicant: **Indesit Company S.p.A.**
60044 Fabriano (AN) (IT)

(74) Representative: **Santonicola, Paolo**
Indesit Company S.p.A.
Industrial Property Management Team
Via Lamberto Corsi, 55
60044 Fabriano (AN) (IT)

(54) **Linen washing machine and relative operating method**

(57) An operating method of a linen washing machine (1) comprising the steps of:

- i) loading a washing liquid into a washing compartment (2), said step of loading the washing liquid comprising:
- the step of introducing the washing liquid until the initial reaching of a first predefined level (L1) envisaged by a level sensor (4);
 - repeatedly topping up the first predefined level (L1) of washing liquid by adding top-up liquid to compensate for the washing liquid absorbed by the linen;

ii) determining a first parameter univocally associated

with the quantity of top-up liquid introduced into the compartment (2) to top up said first predefined level (L1) of washing liquid and compensate for the absorption of the washing liquid by the linen;

iii) determining a set of parameters associated with a quantity of water to be used in a linen rinse step, the step of determining said set of parameters envisaging a comparison of said first parameter with corresponding predetermined discrete intervals of such first parameter, each of said intervals being associated with a corresponding set of parameters associated with the quantity of water to be used in the rinse step.

FIG 1

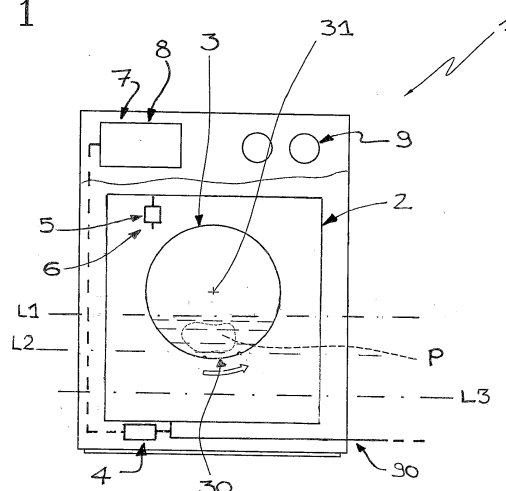

EP 2 733 247 A1

Description

[0001] The present invention relates to a linen washing machine and an operating method of a linen washing machine.

[0002] Washing machines of the prior art envisage a step of washing linen and a subsequent step of rinsing it.

[0003] In particular, washing machines are known wherein the quantity of water to be used during the rinse step is a function of the values rigidly pre-set in the electronic board. In order to avoid wasting water in some of such washing machines the user, by activating a relevant button, can select the half load function. In that case the user can at his discretion decide that the load of linen is moderate and can therefore request a lower quantity of water during the rinse. The half load function is usually associated with a reduction in water consumption and therefore electrical energy also during the actual washing step and not only during the rinse.

[0004] However, this solution is not free from drawbacks. In fact, the choice that the user makes based on his own sensitivity is not always the optimal one. The user often bases his choice on the mass of linen to be washed and not on the degree of water absorption that such linen can offer. For example, the user could decide to use the half load program when he needs to wash products which, whilst having a reduced mass, actually absorb a large quantity of water (which could translate into an insufficient rinse).

[0005] In this context, the technical task underpinning the present invention is to provide a washing machine and method that enables the linen rinse parameters to be optimised, in particular the quantity of water required in such an operation.

[0006] The technical task set and the objects specified are substantially attained by a washing machine and method, comprising the technical characteristics as set out in one or more of the accompanying claims. Further characteristics and advantages of the present invention will appear more clearly from the indicative and non-limiting description of a preferred, but not exclusive, embodiment of a washing machine, as shown in Figure 1.

[0007] In the accompanying drawing, number 1 indicates a linen washing machine. This machine is typically a washing machine, but could also be a washer-dryer.

[0008] As shown by way of example in Figure 1, the washing machine 1 comprises a washing compartment 2. Typically the washing machine 1 comprises a linen housing drum 3 that can rotate and that is placed inside the washing compartment 2.

[0009] The washing machine 1 further comprises a washing liquid level sensor 4 in said compartment 2.

[0010] The level sensor 4 is able to identify a first operating condition in which the measured level is higher than a first predefined level L1 and a second operating condition in which the measured level is lower than a second predefined level L2 (the second level L2 is lower than the first level L1). On this point, the level sensor 4

is usually a pressure switch. For example, the pressure switch could be a differential pressure switch. In this case, in the first operating condition, the pressure switch assumes a first configuration whereas in the second operating condition the pressure switch assumes a second configuration which is physically different from the first configuration. In an alternative embodiment, the pressure switch may also be a linear pressure switch which detects in steps the level variations in the compartment 2. The differential pressure switch, unlike the linear pressure switch, is only able to determine whether a discrete number of pressure thresholds is exceeded or not (usually one or two). As shown by way of example in Figure 1, the pressure switch is placed along a line 90 for unloading the washing liquid from the compartment 2. Appropriately the washing machine 1 comprises washing liquid introduction means 6 into the compartment 2. The washing liquid introduction means 6 are operatively associated with the level sensor 4 and in the first and second operating condition they respectively stop and activate the introduction of washing liquid into the compartment 2. For example, the introduction means 6 comprise a solenoid valve 5 that is closed in the first operating condition, whereas it is open in the second operating condition.

[0011] As will be described more fully below, during a washing liquid loading step a quantity of liquid is initially loaded in order to reach said first predefined level L1. This first predefined level L1 is higher with respect to a lower portion 30 of the housing drum 3. Consequently the linen will absorb part of the washing liquid determining a lowering of the level of liquid in the compartment 2.

[0012] If the level in the compartment 2 drops below the value L2, the reduction in the level will be compensated for by introducing a new quantity of washing liquid (through the introduction means 6) until the first predefined level L1 is reached. This operation will be repeated repeatedly until a condition is reached in which the linen will be substantially completely soaked (a situation in which there is no longer a drop in the level of washing liquid in the compartment 2 due to absorption by the linen). The introduction of the washing liquid to compensate for the drop in level dictated by the absorption by the linen is known as a "top-up" in technical jargon. Appropriately, the washing machine 1 comprises means 7 for determining a first parameter associated with the quantity of washing liquid introduced into the compartment 2 to top up said first level L1 and compensate for the absorption of liquid by the linen. The first parameter in the preferred embodiment is actually the sum of the quantity of liquid introduced during the top-ups. In limit cases, the sum could coincide with the quantity of water introduced in a single top-up or could also be equal to zero (as is also clear from a mathematical point of view if there are no top-ups).

[0013] The machine 1 also comprises comparison means 8 of said first parameter with predetermined intervals of said first parameter. Each of said intervals is

associated with a corresponding set of parameters connected with the quantity of water to be used in the rinse step.

[0014] As also indicated below, such a set of parameters could comprise, for example: number of rinses (the number of rinses could also be equal to "1"), quantity of water to be introduced in each rinse, duration of each individual rinse, etc..

[0015] In the preferred embodiment, the washing machine 1 comprises an electronic control system (for example a main electronic board). The means 7 for determining said first parameter and the aforementioned comparison means 8 are integrated into said electronic control system (e.g. they are integrated into the same electronic board).

[0016] The machine 1 further comprises a selector 9 of the type of linen to be washed. Such a selector 9 could be a knob, a button or a touch screen, etc. It allows the user to choose from a discrete list of items the one he intends to use for washing. The selector 9 is manually activated by the user. In a particular, but non-limiting embodiment, the set of parameters connected with the quantity of water to be used in the rinse step varies as the setting of said selector 9 varies. The utility of the selector 9 is particularly clear in the event of determined items such as quilts, for example. In fact, the applicant has verified that with determined and limited types of products it may be useful to use a specific quantity of water for that type of items by forcing the pre-set optimised algorithm in the machine 1.

[0017] The present invention relates to an operating method of a linen washing machine 1 (in Figure 1 the linen is schematically indicated by the reference letter "P"). This method enables the quantity of rinsing water to be used during the rinse to be optimised. This method can be advantageously implemented by a linen washing machine having one or more of the characteristics described above (for that reason some of the concepts already described will be referred to again below). The washing machine first performs an actual washing cycle followed by a rinse step. The rinse step usually serves the purpose of removing any residue of detergent used in the actual washing step. Typically, but not necessarily, in the rinse step only water is used. The rinse step may envisage the implementation of a plurality of rinses. Each rinse usually envisages the full replacement of the water contained in the compartment 2. In any case, the distinction between the washing cycle and the rinse step is well known in the technical field.

[0018] The method comprises the steps of loading a washing liquid into a washing compartment 2. In the present text washing liquid means a liquid comprising water and any chemical products (detergents, softener, etc.). Appropriately the washing liquid loading step takes place at the start of a washing step. The washing liquid loading step comprises the step of introducing the washing liquid until a first predefined level L1 is initially reached. Such first level L1 is set by a level sensor 4.

The washing compartment 2 contains a drum 3 that can rotate and that is suitable for housing the linen to be washed. The drum 3 can rotate with respect to the axis 31 indicated in Figure 1.

5 **[0019]** The first level L1 surpasses a lower portion 30 of the drum 3. The first level L1 therefore affects the linen placed in the drum 3.

[0020] The washing liquid loading step also envisages introducing into the compartment 2 a top-up liquid following the partial absorption by the linen of the washing liquid already contained in the compartment 2. It is specified that once the top-up liquid has been introduced into the compartment 2 it is also considered washing liquid.

10 **[0021]** In a preferred embodiment the top-up liquid introduction step envisages repeatedly topping up the first level L1 by adding top-up liquid to compensate for the washing liquid absorbed by the linen. The top-up liquid may or may not be of the same type as the washing liquid already contained in the compartment 2.

20 **[0022]** The top-up liquid is normally added once the level in the compartment 2 in a time span predetermined by the reaching of the first level L1 drops below the second predefined level L2. During such time span, the drum 3 is advantageously placed in rotation in order to promote the absorption of the liquid by the linen contained therein.

25 **[0023]** In the preferred embodiment the repetition ends when at the end of a time span predetermined by the last reaching of the level L1, a lower level than the second predefined level L2 is not detected.

30 **[0024]** In practice, at the end of the above-indicated repetition, the linen will be soaked.

35 **[0025]** Advantageously the method also comprises the step of determining a first parameter univocally associated with the quantity of top-up liquid introduced into the compartment 2.

[0026] In a particular embodiment the step of determining a first parameter univocally associated with the quantity of top-up liquid envisages:

- 40 - determining the flow rate of the washing liquid introduced into the compartment 2 through the solenoid valve 5 (this allows the real flow rate of the solenoid valve 5 to be determined in order to take into consideration the effective pressure value of the water supply network and/or any deposits);
- 45 - counting the time in which the solenoid valve 5 is open during said step of repeatedly topping up the first predefined level L1;

50 **[0027]** In that case, the first parameter could be equal or directly proportional to the product of the flow rate and the time in which the solenoid valve 5 remains open during said step of repeatedly topping up the first predefined level L1. Said time is usually equal to the sum of a number

55 of time intervals corresponding to each repetition, but could also correspond to a single time interval (in this case there would only be one top-up); furthermore, in the event that there are no top-ups such time could also be

null. The situation in which there are no top-ups is a situation that could arise if items to be washed, which absorb very little water, are placed in the compartment 2.

[0028] A particularly advantageous way of determining the water flow rate (and therefore estimating the first parameter as indicated above) envisages measuring the time that, with the solenoid valve 5 open, the level of liquid in the compartment 2 takes to rise from one pre-established reference level L3 to said first predefined level L1, said flow rate being a function of the ratio between a first volume and a first time interval (the first volume is equal to the volume of the liquid interposed between the pre-established reference level L3 and the first predefined level L1; the first time interval is equal to the time that, with the solenoid valve 5 open, the level of liquid in the compartment 2 takes to rise from the pre-established reference level L3 to said first predefined level L1).

[0029] In an embodiment shown by way of non-limiting example, the step of measuring the time that, with the solenoid valve 5 open, the level of liquid in the compartment 2 takes to pass from a pre-established reference level L3 to said predefined level L1 takes place during the step (already defined above) of introducing the washing liquid until the initial reaching of the first level L1.

[0030] The method therefore envisages determining a set of parameters associated with the quantity of water to be used in a linen rinse step. The step of determining said set of parameters envisages comparing said first parameter (determined for example according to the indications provided above) with corresponding predetermined intervals of said first parameter. Such intervals are consecutive to each other. Typically the higher the flow rate of the water introduced through the top-ups, the higher the value of said first parameter will be. Each of said intervals of the first parameter corresponds to a set of parameters associated with the quantity of water to be used in the rinse step. The higher the quantity of washing liquid loaded through the top-ups, the higher the quantity of water to be used in the rinse step will be. In fact, the quantity of washing liquid introduced with the top-ups provides an indication of the absorption by the linen. The absorption may vary greatly not only as the mass of the load varies (as the mass increases the absorption increases), but also according to its type (e.g. a cushion of the same mass absorbs more liquid than a pair of shoes). The quantity of water to be used during the rinse is optimised by connecting such a variable with the absorption of liquid by the linen.

[0031] The step of determining the set of parameters associated with the quantity of water to be used in a linen rinse step envisages determining at least the number of rinse cycles to be performed in the rinse step and/or the quantity of water to be introduced in each rinse cycle and/or the duration of each rinse cycle (from which the overall duration of the rinse cycle could immediately be derived).

[0032] In particular, the step of determining the quantity of water to be introduced in each rinse cycle envisages

determining the opening time of the solenoid valve 5 in each rinse cycle or the various levels which when reached in each rinse cycle determine the stopping of the introduction of water into the compartment 2.

[0033] The method finally envisages performing a rinse step by adopting the set of parameters corresponding to the interval identified by said comparison step of said first parameter with corresponding pre-determined intervals of such first parameter.

[0034] The present invention enables many advantages to be attained. First of all, it enables an optimised estimate to be made of the water to be used in the rinse step considering the real requirements of the load (therefore not only influenced by the mass or only by the type of load). A further important advantage is connected with the possibility to directly associate, through a precise correspondence, said first parameter (connected with the absorption of the washing liquid) with said set of parameters (connected with the rinse cycle) without needing to use complicated calculation algorithms (which would require a suitably sized and expensive processor). According to the invention said set of parameters (connected with the rinse) can vary discretely as a function of the interval assumed by the first parameter.

[0035] The invention as conceived is susceptible to numerous modifications and variants, all falling within the scope of the inventive concept characterised thereby. Furthermore all the details can be replaced by other technically equivalent elements. In practice, all the materials used, as well as the dimensions, can be any according to requirements.

Claims

1. An operating method of a linen washing machine (1) comprising the steps of:

i) loading a washing liquid into a washing compartment (2), said washing compartment (2) containing a drum (3) that can rotate and that houses the linen to be washed, said step of loading the washing liquid comprising the sub-steps of:

- introducing the washing liquid until a first pre-defined level (L1) is reached, said first level (L1) surmounting a lower portion (30) of the drum (3);
- introducing into the compartment (2) a top-up liquid following a predetermined absorption by the linen of the washing liquid already contained in the compartment (2); the top-up liquid once introduced into the compartment (2) also being considered washing liquid;

ii) determining a first parameter univocally as-

- sociated with the quantity of top-up liquid introduced into the compartment (2);
- iii) determining a set of parameters associated with a quantity of water to be used in a rinse step of the linen, the step of determining said set of parameters envisaging a comparison of said first parameter with corresponding predetermined intervals of such first parameter, a corresponding set of parameters associated with the quantity of water to be used in a rinse step, being associated with each of said intervals;
- iv) performing a rinse step by adopting the set of parameters corresponding to the interval identified by said comparison step of said first parameter with corresponding pre-determined intervals of such first parameter.
2. The method according to claim 1, **characterised in that** the step of determining the set of parameters associated with the quantity of water to be used in the linen rinse step envisages determining at least the number of rinse cycles to be performed in the rinse step and/or the quantity of water to be introduced in each rinse cycle and/or the duration of each rinse cycle.
3. The method according to claim 2, **characterised in that** the step of determining the quantity of water to be introduced in each rinse cycle envisages determining, for each rinse cycle, the opening time of the solenoid valve (5) or the level that determines the stopping of the introduction of water into the compartment (2).
4. The method according to any one of the previous claims, **characterised in that** the step of determining a first parameter univocally associated with the quantity of top-up liquid envisages:
- determining the flow rate of the washing liquid introduced into the compartment (2) through the solenoid valve (5);
 - counting the time in which the solenoid valve (5) is open during said step of introducing the top-up liquid;
- said first parameter being proportional to the product of the flow rate and the time in which the solenoid valve (5) remains open during said step of introducing the top-up liquid.
5. The method according to claim 4, **characterised in that** the step of determining the water flow rate envisages measuring the time that, with the solenoid valve (5) open, the level of the washing liquid in the compartment (2) takes to rise from one pre-established reference level (L3) to said first pre-defined level (L1), said flow rate being a function of the ratio
- between a first volume and a first time interval; said first volume being equal to the volume of the liquid interposed between the pre-established reference level (L3) and the first pre-defined level (L1); said first time interval being equal to the time that, with the solenoid valve (5) open, the level of washing liquid in the compartment (2) takes to rise from the pre-established reference level (L3) to said first pre-defined level (L1).
6. The method according to any one of the previous claims, **characterised in that** the step of introducing the top-up liquid envisages repeatedly topping up the first pre-defined level (L1) by adding top-up liquid to compensate the washing liquid already contained in the compartment (2) and absorbed by the linen.
7. The method according to claim 6, **characterised in that** the step of repeatedly topping up the first pre-defined level (L1) envisages that every repeat only takes place if within a pre-determined time span from the last reaching of the first level (L1) the level in the compartment (2) has dropped below a second pre-defined level (L2); the second pre-defined level (L2) being lower than the first pre-defined level (L1); during at least a part of said time span the drum (3) within the compartment (2) and containing the linen being made to rotate so as to promote the absorption of the washing liquid by the linen itself.
8. A linen washing machine comprising:
- a washing compartment (2);
 - a washing liquid level sensor (4) in said compartment (2), said level sensor (4) identifying a first operating condition in which the level measured is higher than a first pre-defined level (L1) and a second operating condition in which the level measured is lower than a second pre-defined level (L2);
 - means (6) for introducing the washing liquid into the compartment (2) operatively associated with the level sensor (4) and that when the first and the second operating condition arise respectively stop and activate the introduction of the washing liquid into the compartment (2);
 - means (7) for determining a first parameter associated with the quantity of washing liquid introduced into the compartment (2) to compensate the absorption of the liquid by the linen during a step of loading the washing liquid;
 - means (8) for comparing said first parameter with pre-determined intervals of said first parameter, a corresponding set of parameters connected with the quantity of water to be used in the rinse step being associated with each of said intervals.

9. The machine according to claim 8, **characterised in that** the determination means (7) are determination means (7) of a first parameter associated with the quantity of washing liquid introduced into the compartment (2) for topping up said first pre-defined level (L1). 5
10. The machine according to claim 8 or 9, **characterised in that** it comprises a selector (9) of the type of linen to be washed, said selector (9) being activated manually by a user; said set of parameters varying as the setting of said selector (9) varies. 10

15

20

25

30

35

40

45

50

55

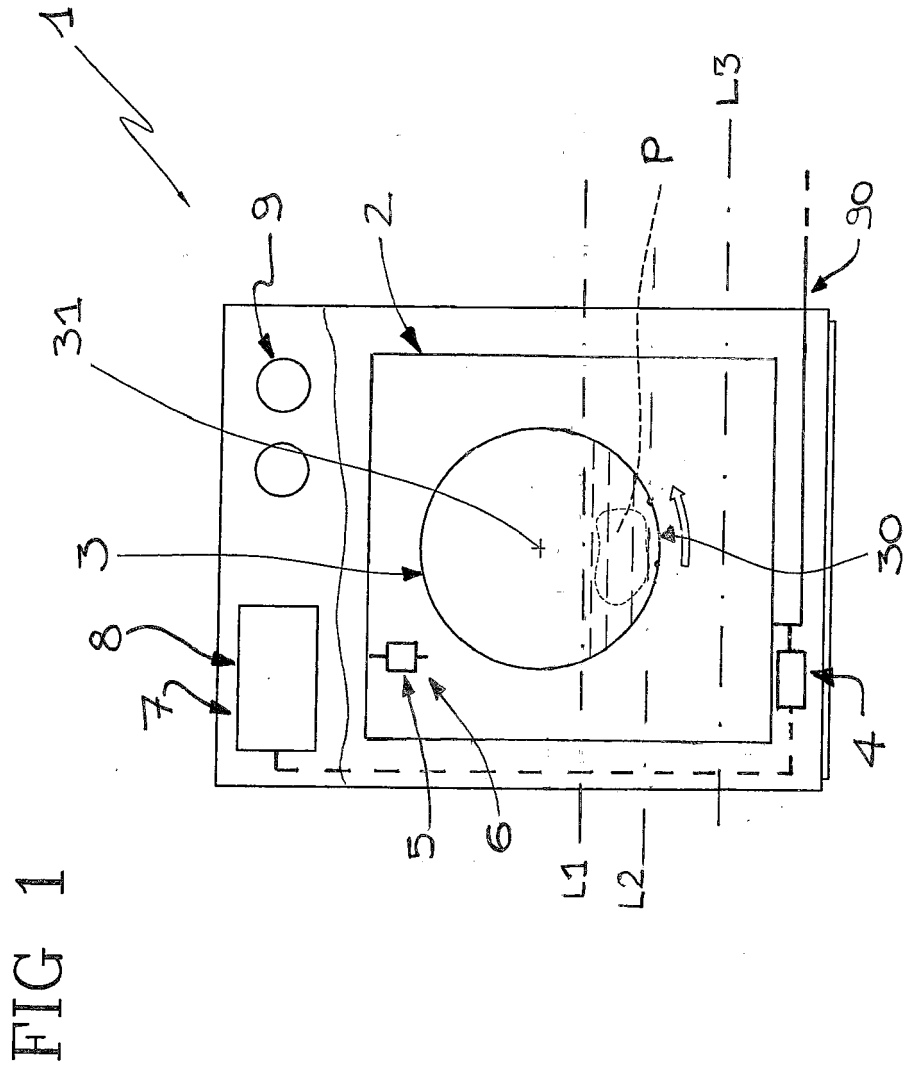



EUROPEAN SEARCH REPORT

Application Number
EP 13 19 3069

DOCUMENTS CONSIDERED TO BE RELEVANT			
Category	Citation of document with indication, where appropriate, of relevant passages	Relevant to claim	CLASSIFICATION OF THE APPLICATION (IPC)
Y	US 2008/189875 A1 (CZYZEWSKI GUNDULA [DE] ET AL) 14 August 2008 (2008-08-14) * paragraphs [0037], [0038]; claim 12; figures 1-2 *	1-10	INV. D06F35/00
Y	----- EP 1 281 803 A1 (SAMSUNG ELECTRONICS CO LTD [KR]) 5 February 2003 (2003-02-05) * paragraphs [0004] - [0006], [0015] - [0017]; claim 1; figures *	1-10	
A	----- EP 2 487 288 A1 (INDESIT CO SPA [IT]) 15 August 2012 (2012-08-15) * paragraph [0011]; claim 1; figure 1 *	1-10	
			TECHNICAL FIELDS SEARCHED (IPC)
			D06F
The present search report has been drawn up for all claims			
Place of search Munich		Date of completion of the search 14 March 2014	Examiner Stroppa, Giovanni
CATEGORY OF CITED DOCUMENTS		T : theory or principle underlying the invention E : earlier patent document, but published on, or after the filing date D : document cited in the application L : document cited for other reasons & : member of the same patent family, corresponding document	
X : particularly relevant if taken alone Y : particularly relevant if combined with another document of the same category A : technological background O : non-written disclosure P : intermediate document			

3
EPO FORM 1503 03.82 (F04C01)

**ANNEX TO THE EUROPEAN SEARCH REPORT
ON EUROPEAN PATENT APPLICATION NO.**

EP 13 19 3069

This annex lists the patent family members relating to the patent documents cited in the above-mentioned European search report. The members are as contained in the European Patent Office EDP file on
The European Patent Office is in no way liable for these particulars which are merely given for the purpose of information.

14-03-2014

Patent document cited in search report	Publication date	Patent family member(s)	Publication date
US 2008189875 A1	14-08-2008	CN 101142356 A	12-03-2008
		DE 102005012426 A1	21-09-2006
		EP 1861537 A1	05-12-2007
		US 2008189875 A1	14-08-2008
		WO 2006097362 A1	21-09-2006

EP 1281803 A1	05-02-2003	DE 60133457 T2	07-05-2009
		EP 1281803 A1	05-02-2003
		ES 2306694 T3	16-11-2008
		JP 2003053094 A	25-02-2003
		KR 20030012218 A	12-02-2003
		US 2003024056 A1	06-02-2003

EP 2487288 A1	15-08-2012	EP 2487288 A1	15-08-2012
		RU 2012104366 A	20-08-2013
