

E. J. BELL.  
 MACHINE FOR BUILDING UP BOARDS FROM PIECES.  
 APPLICATION FILED NOV. 2, 1909.

990,829.

Patented May 2, 1911.

3 SHEETS—SHEET 1.

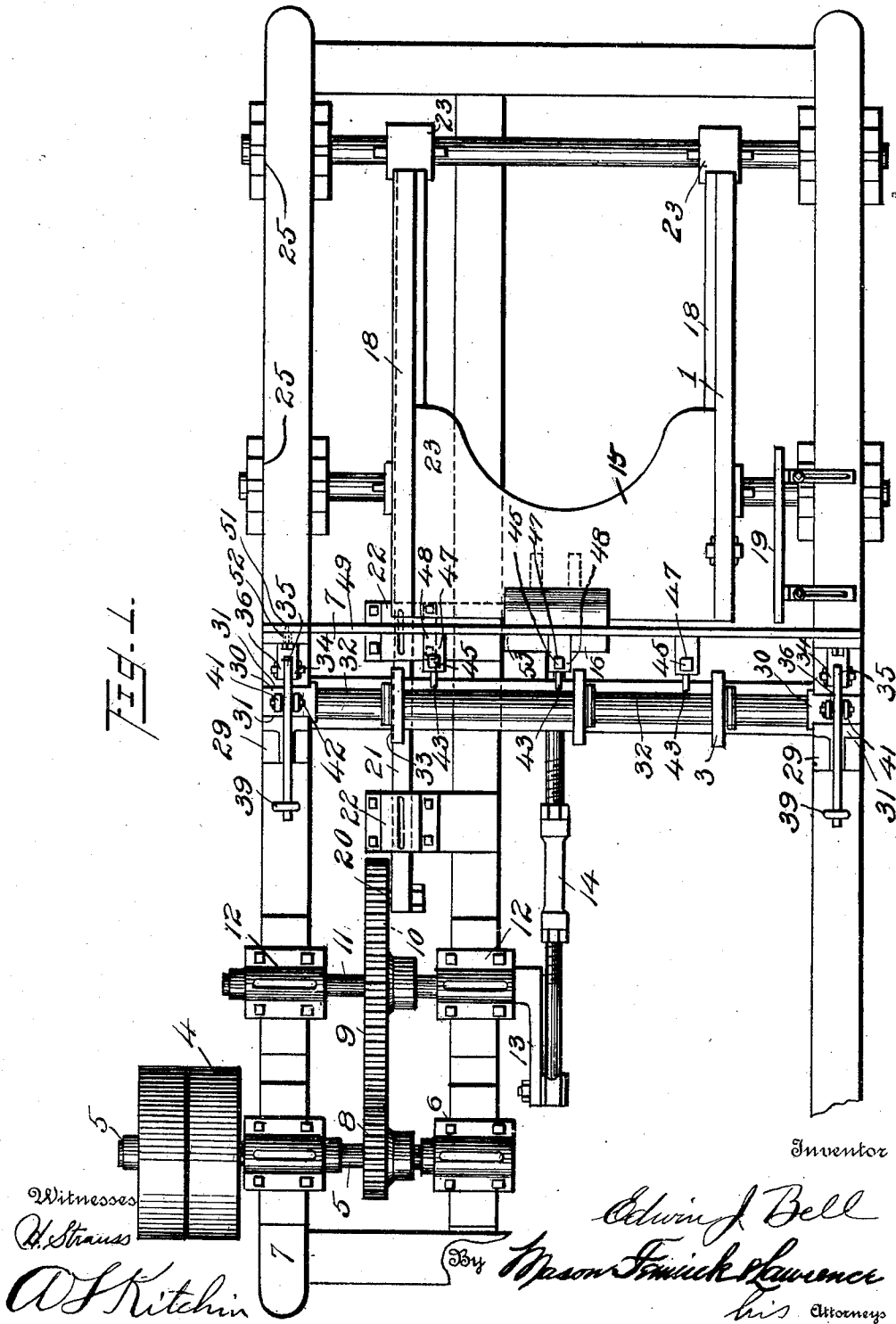

FIG. 1.

Witnesses  
 H. Strauss

*A. S. Kitchen*

Inventor

*Edwin J. Bell*

*Mason, Smith & Lawrence*  
 his Attorneys

E. J. BELL,  
 MACHINE FOR BUILDING UP BOARDS FROM PIECES.  
 APPLICATION FILED NOV. 2, 1909.

990,829.

Patented May 2, 1911.

3 SHEETS—SHEET 2.

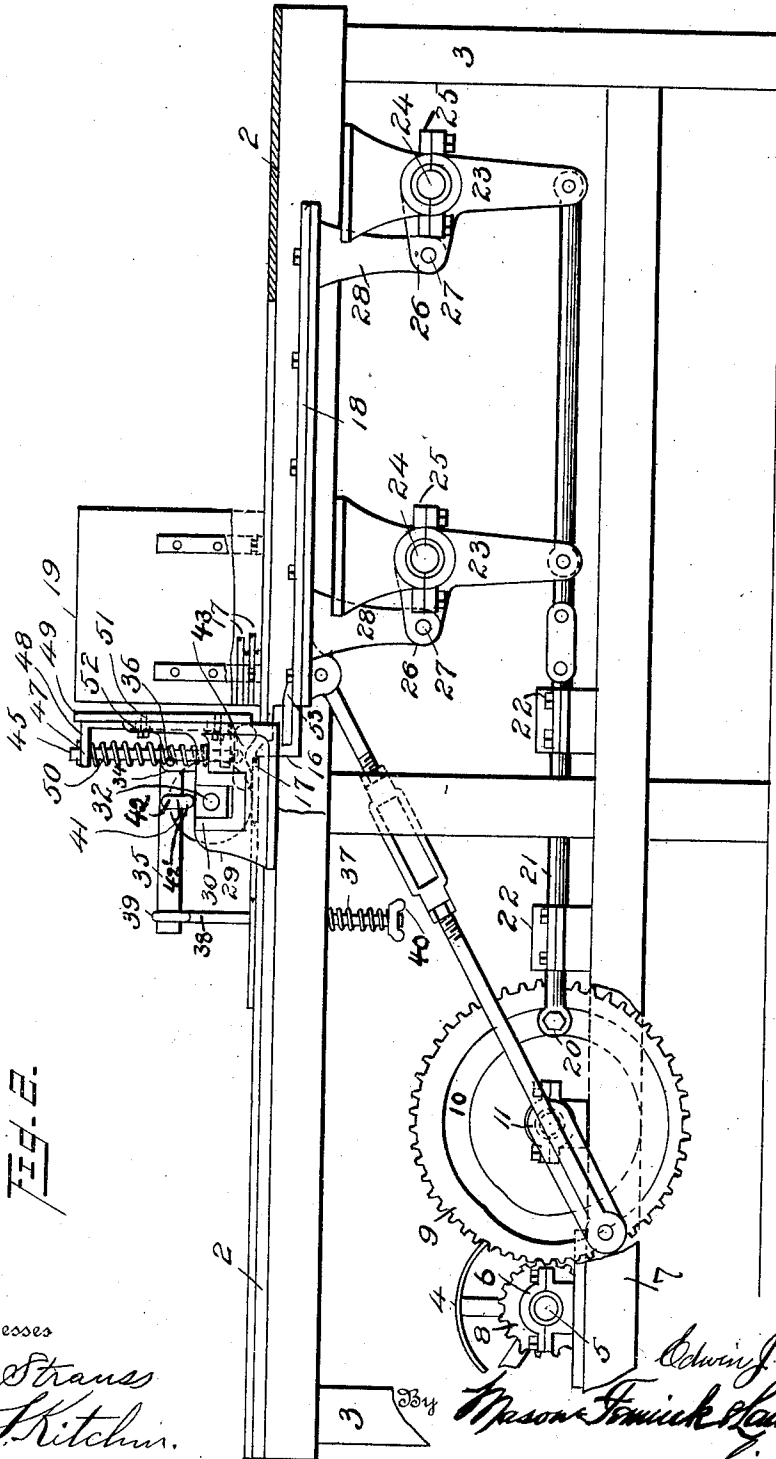

FIG. 2.

Witnesses  
*A. Straus*  
*A. Kitchen.*

Inventor  
*Edwin J. Bell*  
*Mason Finick Lawrence*  
 his Attorneys

E. J. BELL.  
 MACHINE FOR BUILDING UP BOARDS FROM PIECES.  
 APPLICATION FILED NOV. 2, 1909.

990,829.

Patented May 2, 1911.

3 SHEETS—SHEET 3.

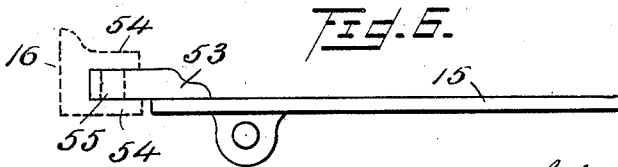
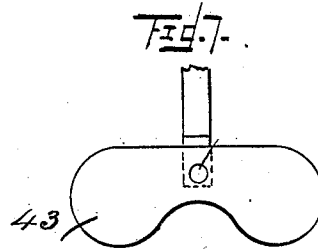
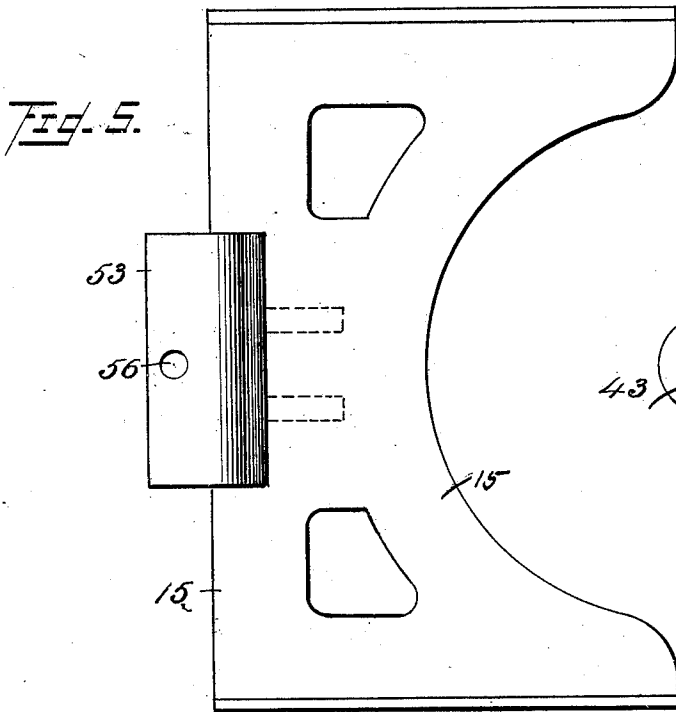
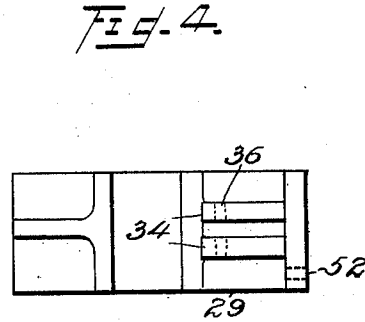
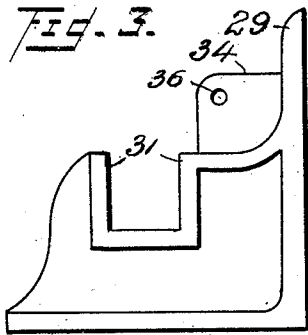

Witnesses

*H. Straus*  
*A. L. Kitchin*

Inventor

*Edwin J. Bell*  
 By *Mason Fenwick Lawrence*  
 his Attorneys

# UNITED STATES PATENT OFFICE.

EDWIN J. BELL, OF OSHKOSH, WISCONSIN.

MACHINE FOR BUILDING UP BOARDS FROM PIECES.

990,829.

Specification of Letters Patent.

Patented May 2, 1911.

Application filed November 2, 1909. Serial No. 525,944.

*To all whom it may concern:*

Be it known that I, EDWIN J. BELL, citizen of the United States, residing at Oshkosh, in the county of Winnebago and State of Wisconsin, have invented certain new and useful Improvements in Machines for Building Up Boards from Pieces, of which the following is a specification.

My invention relates to machines for building up boards from pieces.

My invention provides a means for building up boards from pieces fed to the machine and it is not necessary that the pieces be of equal widths, or the same thickness.

One of the objects of my invention is to provide mechanisms for constructing a continuous board from pieces previously tongued and grooved which are fed to the machine crosswise through a hopper.

A further object of my invention is to provide means for pressing the pieces together as they are fed along.

A further object of my invention is to provide a guide for alinement of said pieces on one end, (one side of the board,) so that the pieces need not necessarily be of the same length.

A further object of my invention is to provide a sufficient retard ahead of the feed and pressure behind the feed to effectually force the tongues of one piece into the grooves of the opposite piece.

A further object of my invention is to provide a means of insuring the proper insertion of the tongue within the groove in boards of varying thickness.

In the accompanying drawing Figure 1 is a plan view of my invention with the table top removed, Fig. 2 is a side view of my invention, Fig. 3 is a side view and Fig. 4 a plan view in detail of one of the sliding-box supporting standards, Fig. 5 is a plan view and Fig. 6 a side view in detail of the sliding table and pusher-head, Fig. 7 is a side view in detail of the two lobed pressure plate.

Referring to the drawing by numerals 2, 2 represents the stationary table top, supported by legs 3, 3, 3.

4 represents the power pulley mounted on the shaft 5 journaled in boxes 6, 6 mounted on the beams 7, 7, constituting a part of the table frame. The pinion 8 is carried by the shaft 5 and engages the gear 9, having an interior cam 10. The gear 9 is mounted on the shaft 11 which is journaled in boxes 12,

12 mounted on the beams 7, 7. The crank 13 is mounted on the end of the shaft 11. The pitman 14 connects the crank arm 13 with the sliding member 15. The pusher-head 16 is attached to the front end of the sliding member 15 and is carried thereby. The table 15 slides in ways 18, 18. The pieces of board 17, 17, etc., are placed in the hopper 19 crosswise, the tongued side to the front, and rest upon the stationary table top 2. As the sliding member 15 carrying the pusher head 16 is moved forward the head 16 engages the lower piece in the hopper and pushes it forward to the position shown in Fig. 2. The roller 20 then operating in the cam 10 causes the pusher head 16 to descend and disappear below the plane of the stationary table-top 2, on its return as carried by the sliding member 15. The roller 20 travels in the cam groove 10 and causes the rod 21 to reciprocate in ways 22 mounted on the beams 7. The reciprocation of the rod 21 rocks the bell-crank levers 23, 23, 23, 23 (Fig. 2) which are hung on shafts 24, 24 journaled in boxes 25, 25, 25, 25 hung from the frame of the machine. The arms 26, 26, 26, 26 of the bell crank levers are pivoted at 27, 27, 27, 27 to lugs 28, 28, 28, 28, integral with the ways 18, 18 in which the sliding member 15 is reciprocated. As the bell crank levers 23, 23 etc. are operated the arms 26, 26, etc., raise and lower the ways 18, 18 and the sliding member 15 and pusher head 16 carried thereby so that when the sliding member is returned by the action of the crank the pusher head is carried back beneath the plane of the stationary table, and does not disturb the pieces in the hopper. The shape of the cam is such and the roller is so positioned that the operation of the roller upon the cam lowers the ways 18, 18 at the time the crank operates to return the sliding member and raises the ways just before the crank operates to start the sliding member forward.

In Fig. 1 the stationary table top 2 which covers the entire table is removed to show the mechanisms beneath.

Referring to Fig. 2 an opening is provided in the stationary top 2 of sufficient width to permit the pusher head 16 to rise above the plane of the top. 29, 29 represent supporting standards bolted to the stationary top. The sliding boxes 30, 30 slide perpendicularly between the jaws 31, 31 provided in each standard. The shaft 32 which

carries the pressure rollers 33, 33, 33 is journaled in the sliding boxes 30, 30. 34, 34 represent jaws integral with each standard between which one end of each pressure lever 35, 35 is pinned at 36. Tension is applied to the opposite end of the pressure levers 35, 35, either by weight or spring.

I have shown in Fig. 2 a spring 37 actuating a rod 38 which is hooked to the end of the pressure lever at 39. The tension of the spring is regulated by the thumb-screw 40. The forked piece 41 is pivoted to the pressure lever at 42. The opposite end 42' impinges against the sliding box 30 in each standard to afford downward pressure upon the sliding boxes carrying the pressure rollers. The downward pressure of the pressure rollers affords a retard to the completed board.

Pressure plates 43 are pivoted to the lower ends of bars 45 at the point 46. The bars 45 are forked at the lower ends for the purpose of making this connection and plates 43 have a slight rocking motion within the fork, which motion is limited by the shoulder between the fork members. The bars 45, square in cross section slide in corresponding openings 47, 47 in each angle bar 48 which is bolted to the front plate 49 of the hopper 19. Downward pressure upon the bars 45 is afforded by the pressure springs 50. Perpendicular adjustment of the front plate 49 relative to the stationary table top 2 is afforded by means of the screw bolts 51, 51 which pass through slots 52, 52 in the standard 29 and screw into front plate 49 holding the two members together. The object of the mechanism is to regulate the location of the front plate 49 of the hopper 19 and the pressure plate 43 relative to the stationary table top to adapt the machine to pieces of different thickness.

It will be observed that the pressure plate 43 has two lobes. The two lobes act to press against the table top the grooved edge of one piece and the tongued edge of the piece following for the purpose of insuring a perfect entry of the tongue into the groove. The plate 43 is permitted to rock slightly to accommodate to uneven pieces or pieces of different thickness.

53 represents a lug integral with the sliding member 15, to which the pusher-head 16 is hung on a flexible joint to permit a lateral rocking motion. The jaws 54, 54 inclose the lug 53 and are pivoted thereto by the pivot 55 passing through the eye 56. The construction is for the purpose of affording flexibility to the pressure to accommodate wedge shaped pieces.

The hopper 19 is open at the top and rear. The pieces are placed one upon another and against the front plate 49, the inside ends against the inside side wall of the hopper. This affords alinement of the pieces at one

end. The opposite ends of the pieces need not be in alinement. The pieces need not be of the same length. The operation of the pusher-head pushes each piece ahead upon the stationary table top. The tension upon the pressure rollers 33, 33, 33 serves to retard the completed board sufficiently to insure a complete matching of the pieces by the action of the pressure head. The two lobed pressure bars 43 press against the opposite pieces as they engage for thoroughly pressing them against the table top at the time they are being matched.

In Fig. 2 the pressure head is shown at the forward end of the stroke. The operation of the cam then lowers the sliding member carrying the pressure head, and the return stroke is effected beneath the table top by the operation of the crank.

The operator may at any time feed a "blank", a piece not tongued or grooved to effect a division of the complete board. By this is meant a blank of any desired length and formed either with a tongue or groove, or without either, may be placed in the hopper at any time, and will eventually be formed into the complete boards as the machine continues to operate.

This invention is adapted to the use of boards either with or without glue. Usually the tongued edge is coated with liquid glue before being placed in the hopper.

Having thus described my invention what I claim is:

1. In a machine of the class described, a frame, a table arranged thereon having an opening therein, a hopper arranged on said table and having one end thereof open, a pair of slide-ways, a reciprocating pusher head mounted on said slide-ways and designed to pass into the opening and beneath the hopper, means for reciprocating said pusher head and for raising and lowering the same, a yielding pressure member for retarding the movement of the manufactured board when the pusher head is pressing a new board against the same, and a pivotally mounted member for pressing the adjoining edges of the manufactured board and the new board being pressed against the same.

2. In a machine of the class described, a frame, a table therefor having a slot therein, a hopper, a sliding member, a pusher-head carried thereby and having pivotal connection therewith, ways for the sliding member, a bell crank lever for raising and lowering said slide-ways, reciprocating means for operating said bell crank lever, a cam for actuating said reciprocating means for causing said bell crank lever to lower the pusher head at one of its extreme movements after the pusher head has moved a board from said hopper against the board being manufactured, means for reciprocating said pusher

head, and means for guiding the boards from said hopper against the board being manufactured.

3. In a device for building up boards, a frame, a stationary table carried thereby, a reciprocating member adjacent to the table, a hopper arranged above the reciprocating member, a plurality of supporting brackets carried by the frame and provided with bearings, a plate secured to such brackets and constituting one side of the hopper, a roll journaled in the brackets and arranged to move toward and away from the table, adjustable means for exerting pressure on the roll, and a pivotally mounted and adjustable pressure device located adjacent to the roll and arranged to engage simultaneously the edge of a board held by the roll and the edge of a board being pressed into contact therewith.

4. In a device for building up boards, a frame, a stationary table carried thereby, a reciprocating member adjacent to the table, a hopper located above the reciprocating member, a plurality of brackets carried by the frame, a plate carried by the brackets, the reciprocating member being adapted to feed boards from the hopper to the table, a pressure device carried by the plate, said device including a vertically reciprocating member and a pivoted foot portion having a limited rocking motion, carried by such

member, provided with a hollowed out under surface, and arranged to contact with the edges of the boards while the latter are being brought into contact with each other by the movement of the reciprocating member.

5. In a device for building up boards, a frame, a stationary table carried thereby and provided with an opening, a hopper, a reciprocating member mounted beneath the hopper, a pusher head carried by the reciprocating member and arranged to enter the opening in the table, means for lifting and lowering said member and pusher head as they reciprocate, a plurality of brackets carried by the frame, a plate carried by the brackets, the pusher head being adapted to feed boards from the hopper to the stationary table, a pressure device carried by the plate, said device including a vertically reciprocating member and a foot portion carried by such member, provided with a hollowed out under surface, and arranged to contact with the edges of the boards while the latter are brought into contact with each other by the movement of the pusher head.

In testimony whereof I affix my signature, in presence of two witnesses.

EDWIN J. BELL.

Witnesses:

A. R. WATERHOUSE,  
ELSA M. GOETTMANN.