

Aug. 8, 1961

E. P. WARNKEN

2,995,294

STATOR CASING AND BLADE ASSEMBLY

Original Filed Dec. 2, 1954

4 Sheets-Sheet 1

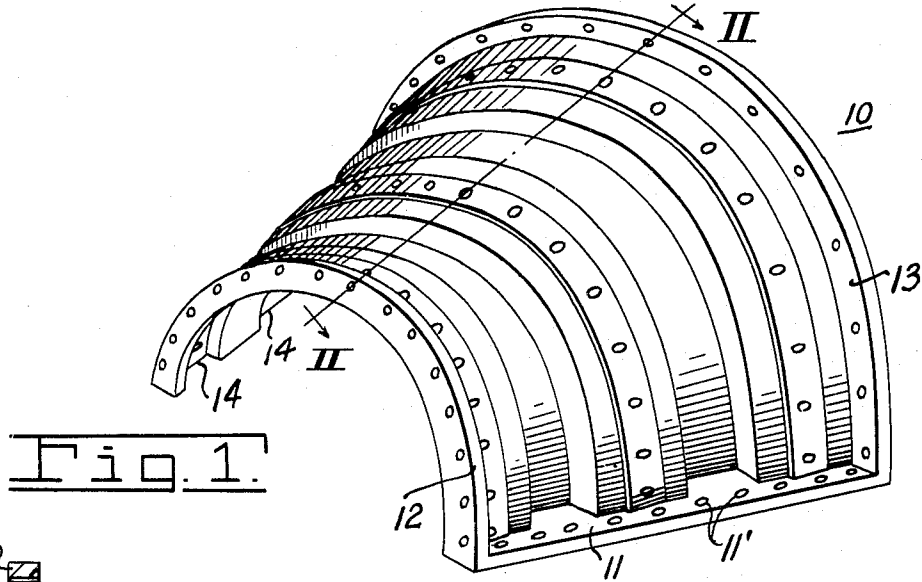

Fig. 1.

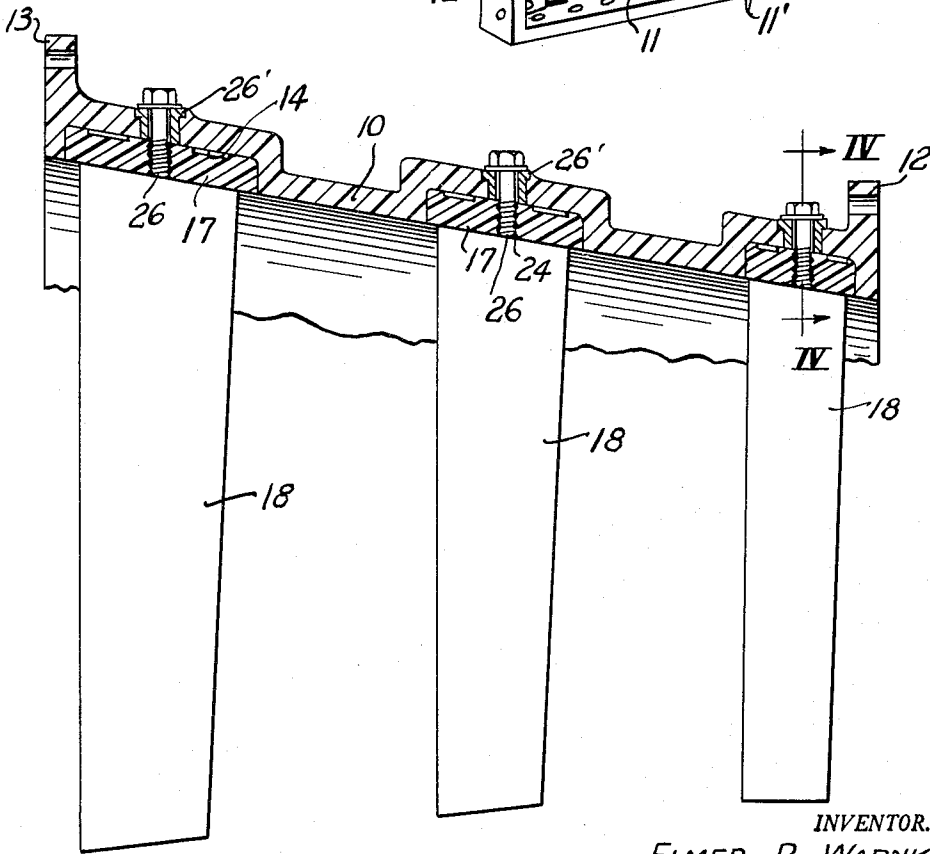

Fig. 2.

INVENTOR.  
ELMER P. WARNKEN  
BY Zugelder and Zugelder

Attys.

Aug. 8, 1961

E. P. WARNKEN

2,995,294

STATOR CASING AND BLADE ASSEMBLY

Original Filed Dec. 2, 1954

4 Sheets-Sheet 2

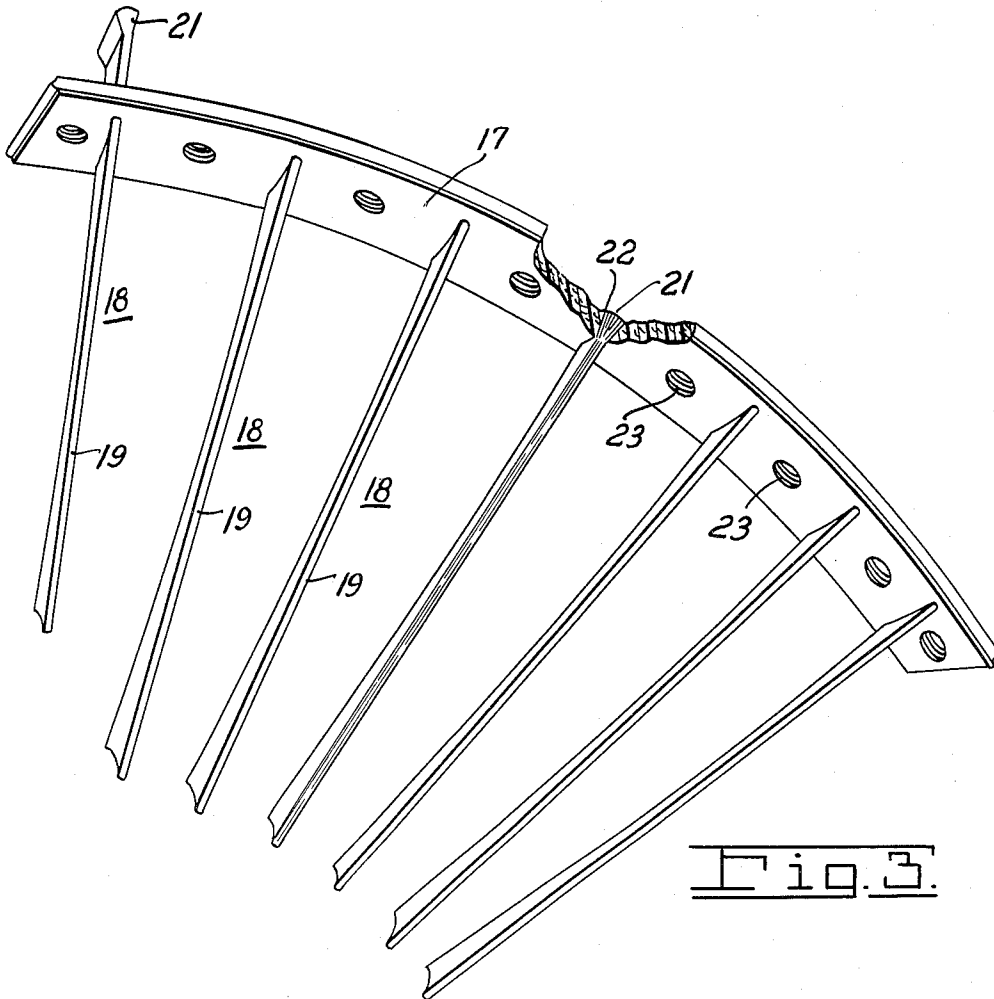

Fig. 3.

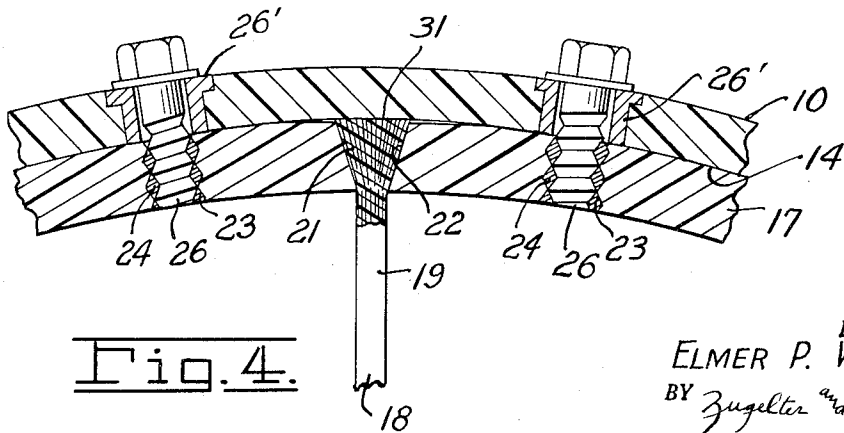

Fig. 4.

INVENTOR.  
ELMER P. WARNKEN  
BY *Zugelder and Zugelder*

*Attys.*

Aug. 8, 1961

E. P. WARNKEN

2,995,294

STATOR CASING AND BLADE ASSEMBLY

Original Filed Dec. 2, 1954

4 Sheets-Sheet 3

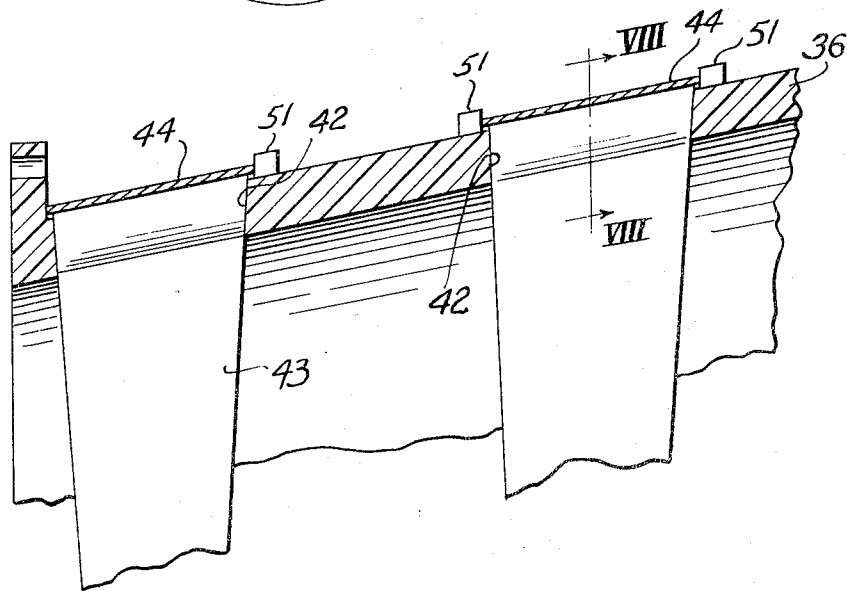
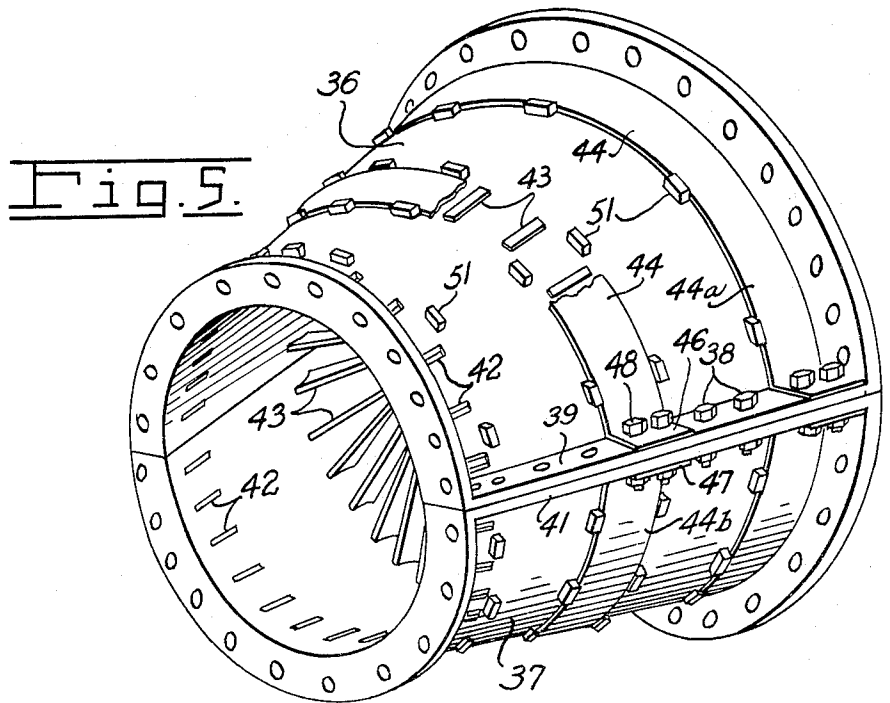

Fig. 6.

INVENTOR.  
ELMER P. WARNKEN  
BY Zugelton and Zugelton

Attys.

Aug. 8, 1961

E. P. WARNKEN

2,995,294

STATOR CASING AND BLADE ASSEMBLY

Original Filed Dec. 2, 1954

4 Sheets-Sheet 4

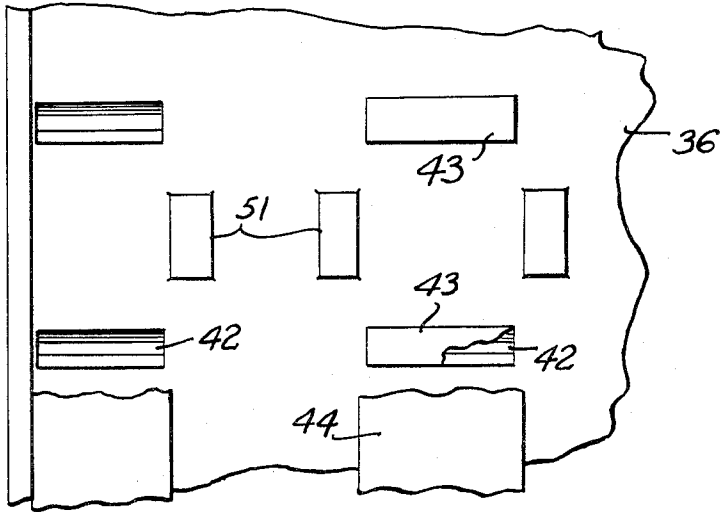

Fig. 7.

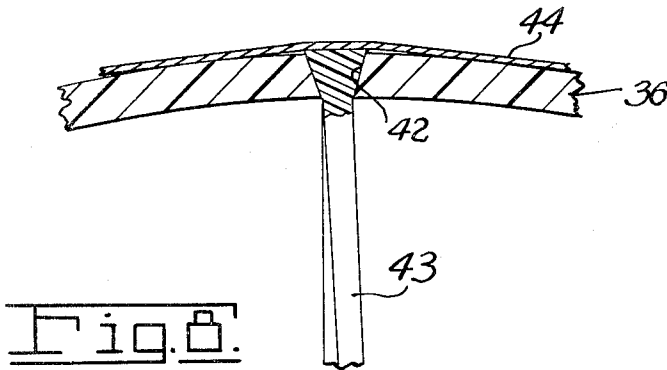

Fig. 8.

INVENTOR.  
ELMER P. WARNKEN  
BY *Zugelder and Zugelder*

*Attys.*

1

2,995,294

**STATOR CASING AND BLADE ASSEMBLY**

Elmer P. Warnken, Cincinnati, Ohio, assignor, by mesne assignments, to Studebaker-Packard Corporation, South Bend, Ind., a corporation of Michigan

Original application Dec. 2, 1954, Ser. No. 472,644, now Patent No. 2,857,093, dated Oct. 21, 1958. Divided and this application May 19, 1958, Ser. No. 736,127  
2 Claims. (Cl. 230-132)

This invention relates to a stator casing and blade assembly for an axial flow compressor such as the compressor section of a jet aircraft engine, or the like. This is a division of my co-pending application Serial No. 472,644, filed December 2, 1954, now Patent No. 2,857,093.

An object of this invention is to provide a stator casing and blade assembly which is simple and easy to construct and which is strong and durable.

A further object of this invention is to provide a stator casing which can be constructed without need for complex machining operations.

A further object of this invention is to provide a stator casing and blade assembly in which individual blades can readily be mounted and from which blades can readily be removed for servicing.

A further object of this invention is to provide a stator casing and blade assembly in which blades having wedge-shaped root end portions are received in slotted segment-shaped members which may be assembled or formed integrally with the casing, the wedge-shaped end of each blade being held firmly in the slot thereof.

A further object of this invention is to provide such an assembly in which the blades extend through segmental members disposed in apertures or slots in an outer casing member, the root ends being larger than the apertures, the root ends of the blades being clamped between the inner wall of the casing and said segmental members.

A further object of this invention is to provide a stator casing and blade assembly in which the casing itself is provided with apertures through which the blades extend, the root ends of the blades being larger than the apertures and being firmly secured therein by an outer wrapping or retaining web or strap embracing the casing and holding the blades firmly in position.

The above and other objects and features of the invention will in part be apparent and will in part be obvious to those skilled in the art to which this invention pertains, from the following detailed description, and the drawings, in which:

FIGURE 1 is a perspective view showing a half section of a casing for an axial flow compressor of an aircraft engine;

FIG. 2 is an enlarged view in section taken on line II—II in FIG. 1 with stator blades mounted therein;

FIG. 3 is a perspective view partly in section showing a segment and blade assembly embodied in the casing section of FIG. 2;

FIG. 4 is a partial view in section taken on line IV—IV in FIG. 2;

FIG. 5 is a perspective view showing a portion of a stator casing including two half sections constructed in accordance with another embodiment of this invention;

FIG. 6 is an enlarged partial view in section taken on line VI—VI of FIG. 5 showing details of mounting the blades in the casing section;

FIG. 7 is a fragmentary plan view of a portion of the casing looking in the direction of the arrows VII—VII in FIG. 6; and

FIG. 8 is a view in section taken along the line VIII—VIII in FIG. 6.

In FIG. 1 is illustrated a half-section 10 of a casing

2

of general frusto-conical shape provided with flanges 11 at the part line thereof (only one of which is shown) provided with bolt holes 11' for use in attaching the half-section 10 to another similar half-section to form a complete casing section. In addition, flanges 12 and 13 are provided at opposite ends of the half-section for use in attaching it to adjacent casing sections of an axial flow compressor.

As shown in FIG. 2, the inner wall of half-section 10 is provided with a plurality of spaced annular grooves 14. Each groove 14 receives a segment 17 provided with a plurality of blades 18.

A segment 17 with its complement of blades 18 is illustrated in FIG. 3. As there illustrated, each blade 18 includes a main or airfoil portion 19 and a root end portion 21. The root end portion 21 of each blade is of wedge shape, the sides of the wedge diverging from the airfoil portion 19 of the blade. The segment 17 is provided with wedge-shaped apertures through which the blades are inserted and in which the portions 21 are received and retained. In addition, the segment is provided with a series of threaded holes 23, in the threads of which a helical member 24 of the "heli-coil" type is received. The heli-coil 24 registers with the threads of a bolt 26. In FIG. 4, the size of the heli-coil is exaggerated for clarity of showing.

As shown in FIG. 2, the segments 17 are held in the grooves 14 by means of the bolts 26. The bolts are received in metal bushings 26' located in the bolt holes in the casing 10, as shown.

As shown in FIG. 4, the outer end 31 of the wedge-shaped root 21 of each blade projects outwardly of the segment 17 a short distance and engages the base of the groove 14, so that when the bolts 26 are drawn tight, the root portions 21 are wedged firmly in position in the apertures 22 of segment 17.

The casing and the segments may be formed of metal or of resin-impregnated glass fabric. Since there is no undercutting at the grooves, the casing may be molded and requires little or no machining. Preferably the casing and the segments are formed of resin-impregnated fibre glass, or the like, and the blades may be formed of similar material, and all the major parts are molded to shape.

In the device illustrated in FIGS. 1-4, inclusive, stator blades of a cantilever type are shown. However, if desired, the blades may be stayed at the inner ends by a support ring or shroud of the type which is common in axial flow compressors.

In FIGS. 5-8 inclusive is shown a section of a stator casing and blade assembly constructed in accordance with another embodiment of the invention. The stator casing section of FIG. 5 includes two half-sections 36 and 37. The half-sections are held together by bolts 38 which extend through flanges 39 and 41 on the casing half-sections. As shown in FIGS. 5 and 6, each half-section is provided with a plurality of apertures or slots 42. The slots 42 are of wedge-shape in section as shown in FIG. 8. Each of these slots can receive a blade 43 which may be similar in construction to one of the blades already described. The blades project through the walls of the casing sections with the root ends of the blades being received in the openings 42 and a small portion of each root end extending outwardly of the casing.

The blades are held in place in the slots 42 by straps 44. Each strap includes an upper portion 44a and a lower portion 44b. The ends of the upper and lower portions of each strap are bent outwardly to form tabs 46 and 47. The tabs 46 and 47 are provided with aligned openings for receiving bolts 48 which draw the strips tightly against the wall of the casing and against the outer ends of the blades to hold the blades in position with the airfoil por-

3

tions of the blades projecting into the casing, as shown in FIGS. 6 and 8. The straps are mounted on the casing section between lines of lugs 51 which hold the straps in alignment with the rows of slots 42.

The casing sections of the device illustrated in FIGS. 5-8 may be molded of resin-impregnated glass fabric, or the like, and the blades may be of similar construction. However, both the casing sections and the blades may be formed of other materials such as light strong metals, or the like, if preferred. The wrapping strap may be stainless steel or other material of high tensile strength.

The stator casing and blade assemblies illustrated in the drawings, and described above, are subject to structural modification without departing from the spirit and scope of the appended claims.

Having described my invention, what I claim as new, and desire to secure by Letters Patent is:

1. A stator casing and blade assembly for an axial flow compressor which comprises a plurality of stator blades, each of said stator blades having an airfoil portion and a root end portion, the root end portion being of wedge shape with the wedge diverging from the airfoil portion, a hollow casing, an elongated blade-holding strip of segment-shape fitting inside of and substantially conforming with a portion of the interior of the casing and provided with a plurality of radially outward expanding wedge-shaped slots extending through the strip for receiving the root end portions of the blades, there being a section on the interior of the casing having an inwardly directed face complementary to an outer face of the blade-holding strip for receiving the blade-holding strip with the wide ends of the slots opposed to said face of the casing, the wide ends of the blades extending free of the outer face of the blade-holding strip, and means mounted in the casing and engaging the blade holding strip, for attaching the blade-holding strip to the casing with the wide ends of the root end portions of the blades engaging said facing of the

4

casing to urge the root end portion of each blade firmly into the slot associated therewith and secure each blade to the blade-holding strip.

2. A stator casing and blade assembly for an axial flow compressor which comprises a plurality of stator blades, each of said blades having an airfoil portion and a root end portion, the root end portion being of wedge-shape with the wedge diverging from the airfoil portion, a plurality of hollow casing sections, a plurality of elongated blade-holding strips of segment-shape fitting inside of and substantially conforming with a portion of the interior of the casing sections, each of said blade-holding strips having radially outward expanding wedge-shaped slots extending through the strip for receiving the root end portions of the blades, there being inwardly directed faces on said casing sections complementary to outer faces of the blade-holding strips for receiving said blade-holding strips with the wide ends of the slots opposed to said faces of said casing sections, the wide ends of the root end portions of the blades extending free of the outer faces of the blade-holding strips, and means mounted in the casing sections and engageable with each blade holding strip for attaching the blade holding strips to the casing sections with the wide ends of the root end portions of the blades engaging said faces to urge the root end portion of each blade firmly into the slot associated therewith and secure each blade to one of the blade-holding strips.

#### References Cited in the file of this patent

##### UNITED STATES PATENTS

1,187,428 Homersham ----- June 13, 1916

##### FOREIGN PATENTS

35 572,859 Great Britain ----- Oct. 26, 1945  
660,383 Great Britain ----- Nov. 7, 1951

UNITED STATES PATENT OFFICE  
CERTIFICATE OF CORRECTION

Patent No. 2,995,294

August 8, 1961

Elmer P. Warnken

It is hereby certified that error appears in the above numbered patent requiring correction and that the said Letters Patent should read as corrected below.

Column 3, line 37, for "facing" read -- face --.

Signed and sealed this 7th day of November 1961.

(SEAL)

Attest:

ERNEST W. SWIDER  
Attesting Officer

DAVID L. LADD  
Commissioner of Patents  
USCOMM-DC