

(No Model.)

C. H. & W. A. PRESTON.
STEAM GENERATOR.

No. 523,868.

Patented July 31, 1894.

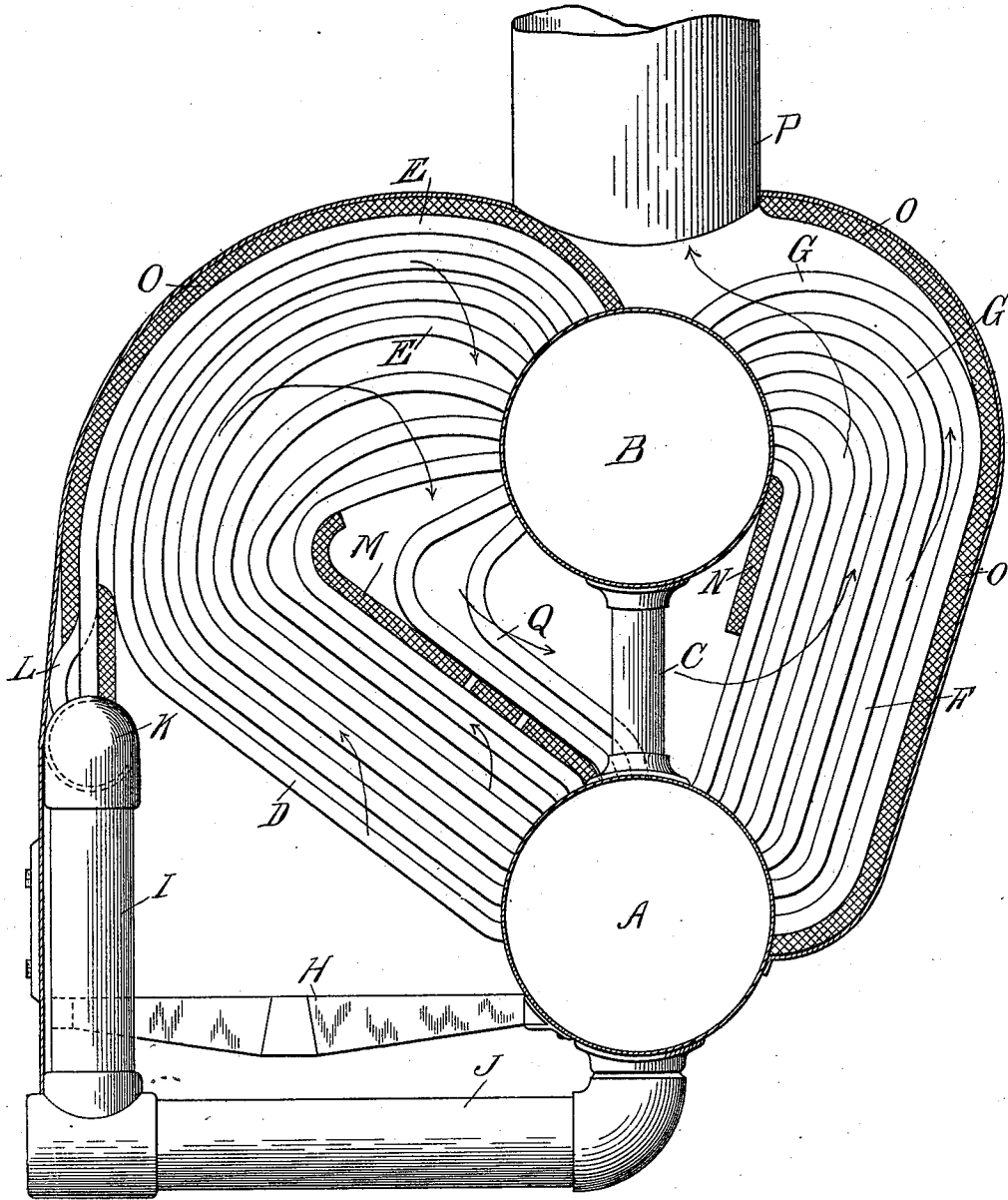

—Witnesses—

O. F. Barrett
W. M. O'Leary

—Inventors—

Charles H. Preston,

William A. Preston,

By *Wm. S. Sprague & Son*
Attys.

UNITED STATES PATENT OFFICE.

CHARLES H. PRESTON AND WILLIAM A. PRESTON, OF DETROIT, MICHIGAN.

STEAM-GENERATOR.

SPECIFICATION forming part of Letters Patent No. 523,868, dated July 31, 1894.

Application filed March 19, 1894. Serial No. 504,178. (No model.)

To all whom it may concern:

Be it known that we, CHARLES H. PRESTON and WILLIAM A. PRESTON, citizens of the United States, residing at Detroit, in the county of Wayne and State of Michigan, have invented certain new and useful Improvements in Steam-Generators, of which the following is a specification, reference being had therein to the accompanying drawing.

10 The invention consists in the peculiar construction of a tubular steam generator comprising two connecting drums arranged one above the other, two series of tubes extending from opposite sides of the lower drum and
15 connected into the upper surface of the upper drum, a grate and deflector plates so constructed that the products of combustion from the grate pass successively from both series of tubes before finding exit through the stack, and further in the peculiar construction and
20 arrangement of these tubes so that the products of combustion pass almost the entire length of both series of tubes, that is, from the bottom toward the top in both series, and
25 further, in the peculiar construction, arrangement and combination of the various parts.

In the drawing, we have shown a central cross-section through a steam generator embodying our invention.

30 A is a lower drum, and what for convenience sake, we will term the water drum, B is the upper or steam drum.

C is a series of vertical pipes or necks extending from the top of the drum A into the
35 bottom of the drum B. Extending from the front upper face of the drum, A, are a series of tubes, having the inclined section D and the curved upper section E, at their upper ends they connect into the upper front face
40 of the steam drum B.

From the rear upper face of the drum A extend a series of tubes F which have the upper curved section G connecting at their ends into the rear upper face of the drum B.

45 H is the grate supported at its rear end upon the forward face of the drum A and at its forward end upon a cross-bar between the water columns I. These water columns at their lower ends are connected by the pipes J
50 to the under side of the drum A, and at their tops they are connected together by the head

K from which extends a series of curved pipes L, connected into the upper face of the drum B.

M is a deflector plate, preferably of asbestos or other similar material arranged on top of the inclined section D of the forward tubes and above the grate. 55

N is a deflector plate secured on the front face of the rear series F of the tubes and extending from the drum B downward. 60

O is a suitable covering, preferably of asbestos around the outside of the tubes.

P is the smoke stack; the arrows indicate the direction of the products of combustion.

It will be observed that the inclined section
65 D of the forward pipes are arranged entirely over the grate, so that they get the direct effect of the radiation from the fire. The products of combustion are deflected from the plate M starting from the base of the section
70 D of the forward tubes upwardly between the plate M and the casing O, then downward between the upper end of the casing M and the drum B between the two drums below the plate N starting at the base of the tubes F and
75 thence upwardly through those tubes to the smoke stack, thus it will be seen that the heat traverses the entire length of both sections of tubes starting from the bottom and going to the top in both instances. 80

We may and preferably do, arrange a third series of pipes Q extending centrally from the top of the drum A into the lower portion of the drum B above the plate M, so as to more effectually use the products of combustion
85 while passing downward from the upper portion E of the tubes between the two drums.

What we claim as our invention is—

1. In a steam generator, the combination with the casing of the water drum and the
90 steam drum arranged one above the other and connected, the two series of relatively different inclination water tubes extending from opposite sides of the water drum and connected at their upper ends into opposite sides
95 of the steam drum, and deflector plates arranged to direct the products of combustion successively through both series of the tubes, substantially as described.

2. In a steam generator, the combination
100 with the casing of the water drum and steam drum vertically arranged and connected, of

the two sets of differently inclined curved water tubes connected from opposite sides of the water drum into the steam drum the grate, and the deflector plates so arranged that the products of combustion pass over both series of water tubes successively from the bottom to the top, substantially as described.

3. In a steam generator, the combination with the casing of the water drum A, the steam drum B above the same, the vertical pipes C connecting the two drums, a series of water tubes extending from the front upper face of the water drum and connecting into the front upper face of the steam drum, comprising the forward inclined section D and the return curved section E, a series of water tubes connected into the rear upper face of the water drum and the rear upper face of the steam drum comprising the sections F and G, the deflector plates arranged as described, the water tubes Q between the deflector plates, the water columns I at the front connected at their lower ends into the water drum and connected at their upper ends by a cross-head K and the water tubes L extending from said cross-head into the top of the steam drum the parts arranged as and for the purpose described.

4. In a steam generator, the combination of the water drum, the steam drum above the same, the vertical pipe connecting the two drums, a series of water tubes extending from the front upper face of the water drum and connecting into the front upper face of the steam drum, comprising the forward inclined section D and the return curved section E, a combustion chamber below the inclined section D of the pipes, a deflector plate on top of the section D of the pipes, arranged in the path of the product of combustion, a series of water tubes connected into the rear upper face of the water drum and the rear upper face of the steam drum, comprising the inclined section F and the curved section G, and a deflector plate on the front face of the section F, and a covering O arranged around the outside of the forward series of tubes, substantially as described.

In testimony whereof we affix our signatures in presence of two witnesses.

CHARLES H. PRESTON.
WILLIAM A. PRESTON.

Witnesses:

M. B. O'DOGHERTY,
O. F. BARTHEL.