

No. 792,702.

PATENTED JUNE 20, 1905.

F. GUTMANN.  
DISCHARGER FOR WOOL DRIERS.  
APPLICATION FILED MAR. 23, 1904.

2 SHEETS—SHEET 1.

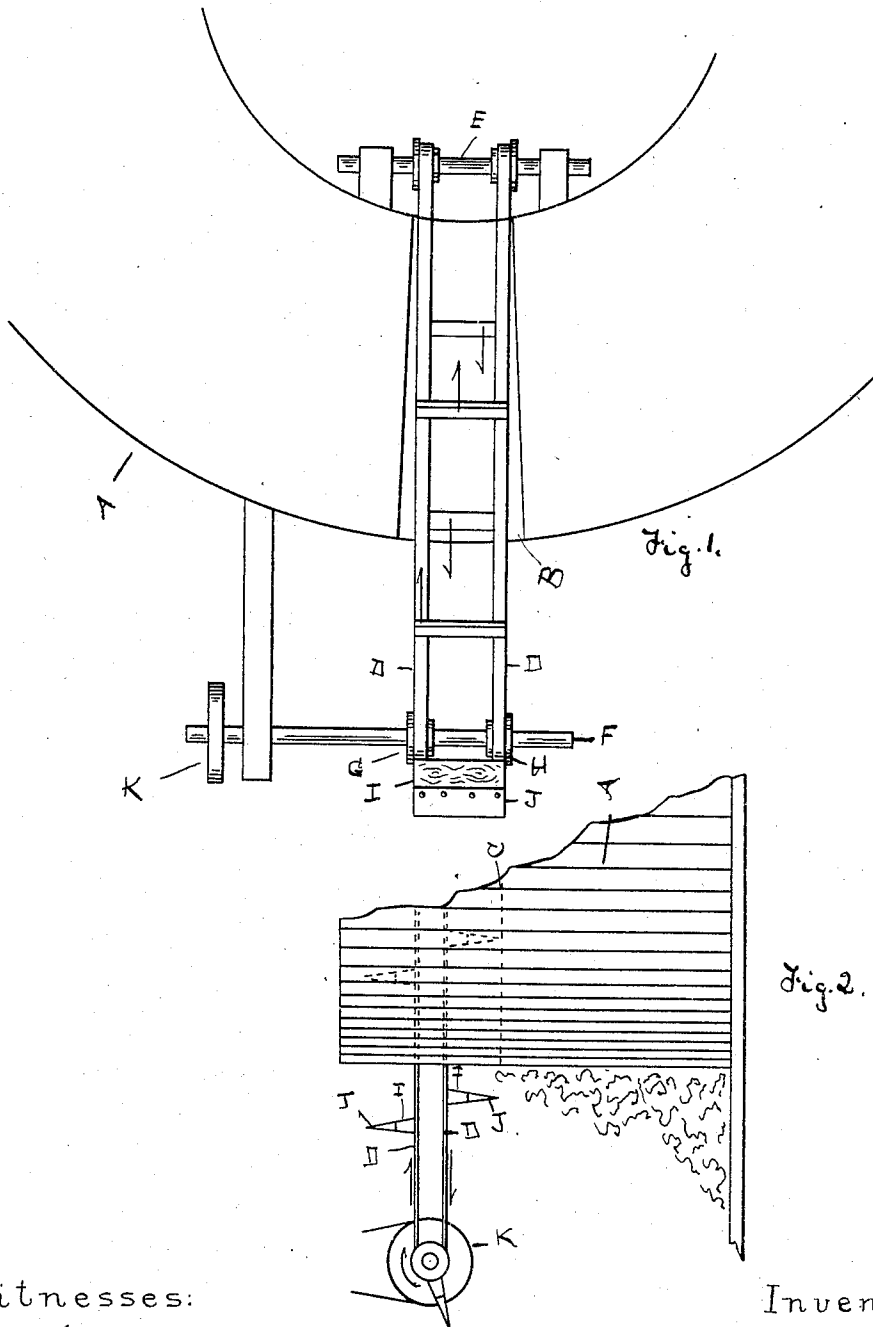

Witnesses:

*G. L. Gutmann*  
*Wm. H. Sewell*

Inventor:

*Frank Gutmann*

F. GUTMANN,  
DISCHARGER FOR WOOL DRIERS.

APPLICATION FILED MAR. 23, 1904.

2 SHEETS—SHEET 2.

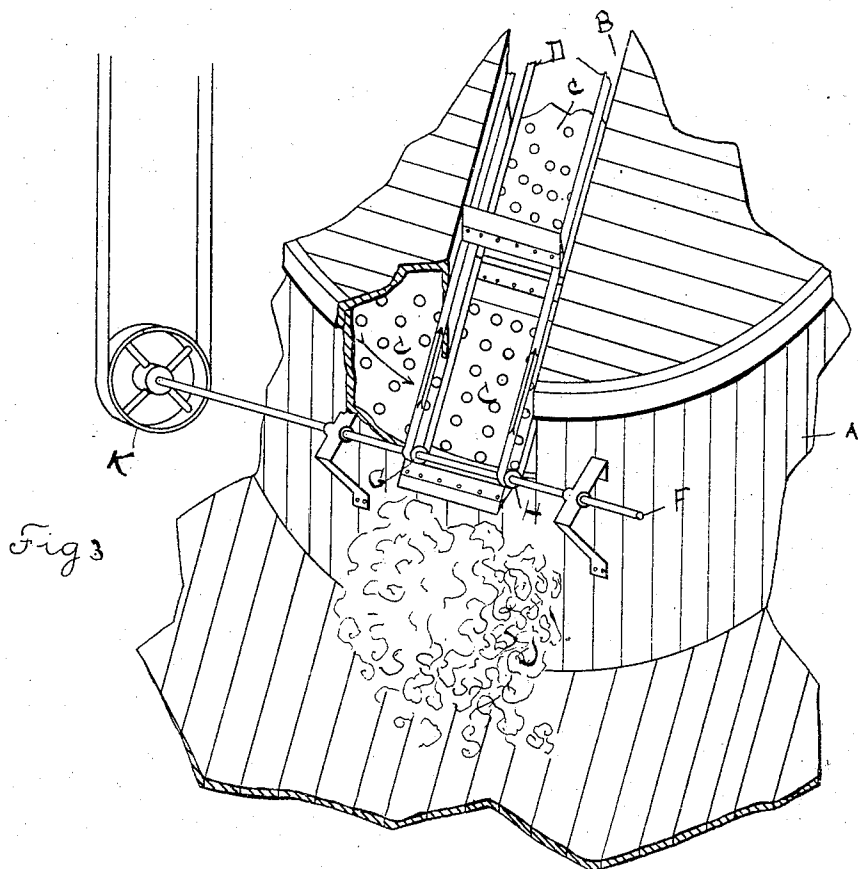

Fig 3

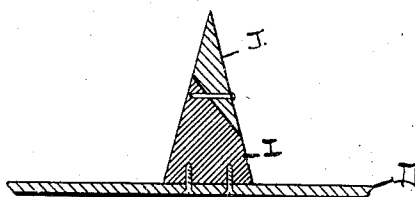

Fig 4

WITNESSES:

Marion Richards,  
Lydia H. Beck.

INVENTOR:

Frank Gutmann

by  
Christopher Clifford  
Attorneys.

# UNITED STATES PATENT OFFICE.

FRANK GUTMANN, OF LEWISTON, MAINE.

## DISCHARGER FOR WOOL-DRIERS.

SPECIFICATION forming part of Letters Patent No. 792,702, dated June 20, 1905.

Application filed March 23, 1904. Serial No. 199,612.

*To all whom it may concern:*

Be it known that I, FRANK GUTMANN, a citizen of the United States, residing at Lewiston, in the county of Androscoggin and State of  
5 Maine, have invented new and useful Improvements in Dischargers for Wool - Driers, of which the following is a specification.

This invention relates to improvements in devices for removing wool from driers, and  
10 is especially adapted to that class of driers known as "rotary" driers. The wool has usually been discharged from driers by means of blowers. This has caused considerable annoyance, for the force of the draft required  
15 to blow the wool from the drying-table widely dissipates the wool and fills the room which contains the drier with dust and fine particles of wool to such an extent that it makes it almost impossible for workmen to stay in the  
20 room any length of time, and likewise it has been necessary when using the blower-discharger to have the driers in separate rooms, because if this was not done the dust and  
25 particles of wool would be sent all over the mill. In my device this difficulty is obviated from the fact that the wool is scraped from the drying-table and removed from there without stirring up dust or sending small particles of  
30 wool into the air.

In the drawings herewith accompanying and forming a part of this application, Figure 1 is a top plan view of the drier, showing my improved device thereon; and Fig. 2 is a side  
35 elevation. Fig. 3 is a perspective view, parts being broken away, showing the improved scraper and improved table. Fig. 4 is a sectional view showing the construction of the scraper.

Same letters of reference refer to like parts  
40 in all the figures.

In said drawings, A represents the frame of a drier, which may be of any desired construction and of that kind commonly known as a "revolving" drier. In a suitable channel  
45 B in the drier and over the revolving table C, I place my improved discharger, which consists of two endless parallel belts D. Said belts are held in position by means of a shaft and pulleys E, mounted in any suitable man-  
50 ner near the center of the drier. In front of

the drier and beyond the discharger-opening is a shaft F, supported in any suitable manner, having thereon driving-pulleys G and H. The parallel endless belts run over these pulleys and the inner shaft in the direction indicated by the arrows in the drawings. The  
55 endless parallel belts are provided with scrapers arranged at distances apart on the belts, a part of the scraper I being of some hard substance, as wood, the lower or bearing part J thereof  
60 being constructed of rubber or leather or some similar flexible material. Motion is imparted to the shaft by a pulley K, which is belted to the regular shafting in a mill, or motion may be imparted to said shafts in any other  
65 suitable manner.

The operation of my device is as follows: After the wool has been placed in the drier and on the revolving table as the table revolves and the wool is brought into the  
70 discharger-opening the scrapers on the parallel endless belts remove the wool from the table and deposit the same upon the floor or on any suitable receptacle thereof, the belts moving continuously and at such a predetermined rate  
75 of speed as to insure the complete discharge of the dried wool from the discharge-opening B as said wool is brought there by the revolving table. By this continuous movement they prevent any of the dried wool from  
80 going back into the drier as the table moves beyond the discharge-opening.

The advantages of my improved drier are, first, that it can be very cheaply constructed, is very simple in operation, and requires a  
85 much less horse-power to run it than is required to run the ordinary blower and also obviates the filling of the air in the drier-room with dust and particles of wool.

Having thus described my invention and its  
90 use, I claim—

1. In a discharge for wool-driers, endless parallel belts having at predetermined distances apart vertical scrapers, said scrapers being composed partly of rigid and partly of  
95 flexible material, the flexible portion of the scrapers being adapted to bear gently upon the revolving table of the drier.

2. A discharger for wool-driers consisting of endless parallel belts having vertical  
100

scrapers attached thereto at predetermined distances, said scrapers being composed partly of rigid and partly of flexible material, the flexible material being adapted to bear upon the revolving table of a drier, shaft and pulleys mounted on the drier-frame and means for causing said parallel belts to travel over said shaft and pulleys.

3. A discharger for wool-driers consisting of endless parallel belts, having vertically-disposed scrapers thereon connecting said parallel belts, the portion of said scrapers contiguous to said belts being of some rigid

material, their free ends composed of flexible material, means for supporting said belts so that the flexible ends thereof shall bear upon the drying-table and means for imparting motion to said belts.

In testimony whereof I have hereto affixed my name, in presence of two subscribing witnesses, this 14th day of March, 1904.

FRANK GUTMANN.

In presence of—

G. L. GUTMANN,  
WM. H. NEWELL.