



US 20130340572A1

(19) **United States**

(12) **Patent Application Publication**  
**Flusche**

(10) **Pub. No.: US 2013/0340572 A1**

(43) **Pub. Date: Dec. 26, 2013**

(54) **LONG LATERAL COMPLETION SYSTEM  
PIPE TONG AND METHOD OF USING THE  
SAME**

(52) **U.S. Cl.**  
USPC ..... **81/57.4; 173/1**

(75) **Inventor: Mark J. Flusche, Muenster, TX (US)**

(57) **ABSTRACT**

(73) **Assignee: Complete Production Services, Inc.,  
Houston, TX (US)**

The present disclosure relates to a completion system and method adapted for use in wells having long lateral boreholes. Particularly, the present disclosure relates to a pipe tong fixture for a conventional pipe tong apparatus, which may be installed within a mast for a long lateral completion system. The pipe tong fixture allows for the movement and precise control of the conventional pipe tong apparatus in relation to a borehole for efficient and safe remote operation of the pipe tong fixture and conventional pipe tong apparatus. The present disclosure also relates to torque measurement and the communication and analysis of such measurements during a completion.

(21) **Appl. No.: 13/507,326**

(22) **Filed: Jun. 21, 2012**

**Publication Classification**

(51) **Int. Cl.**  
**E21B 19/16** (2006.01)  
**E21B 15/00** (2006.01)

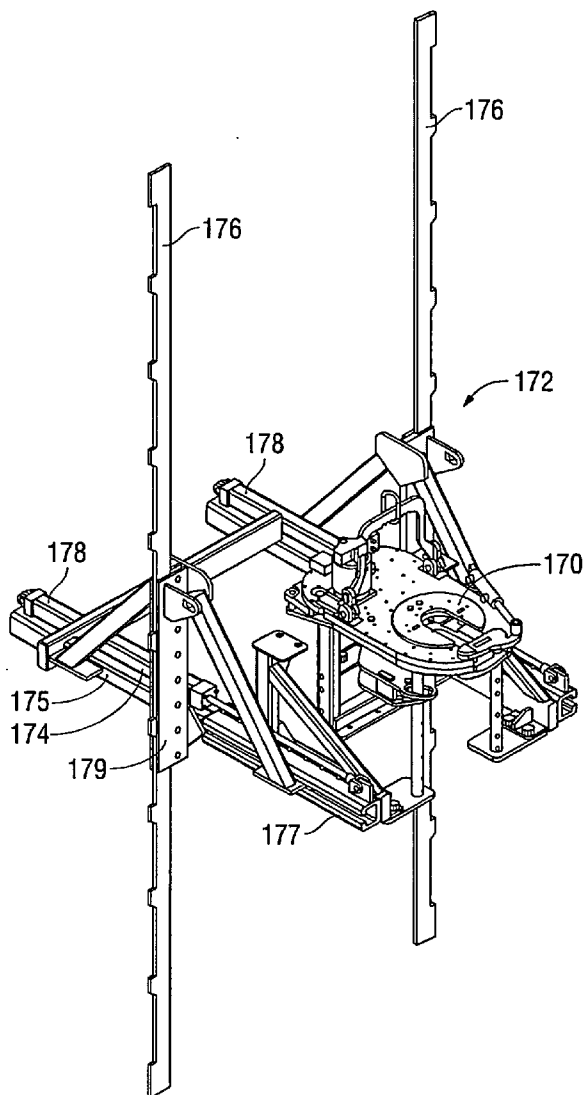

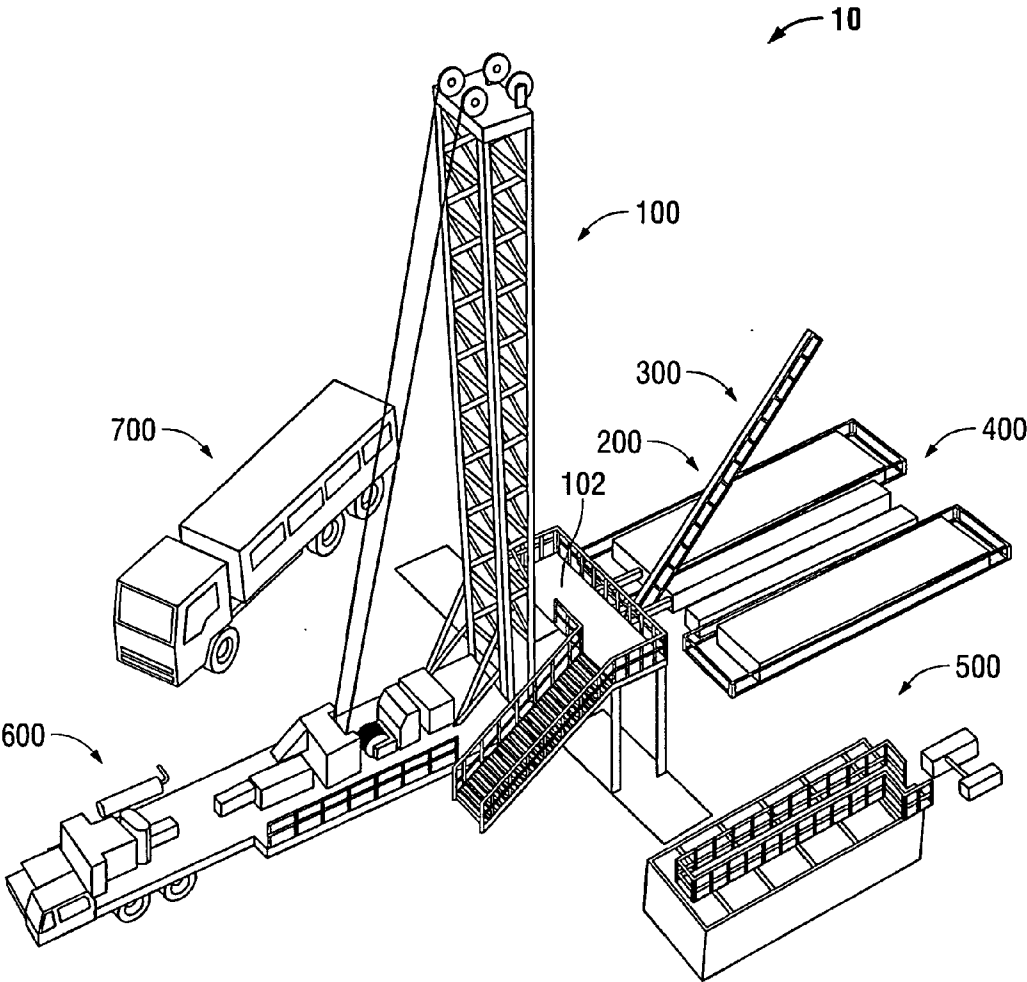

FIG. 1

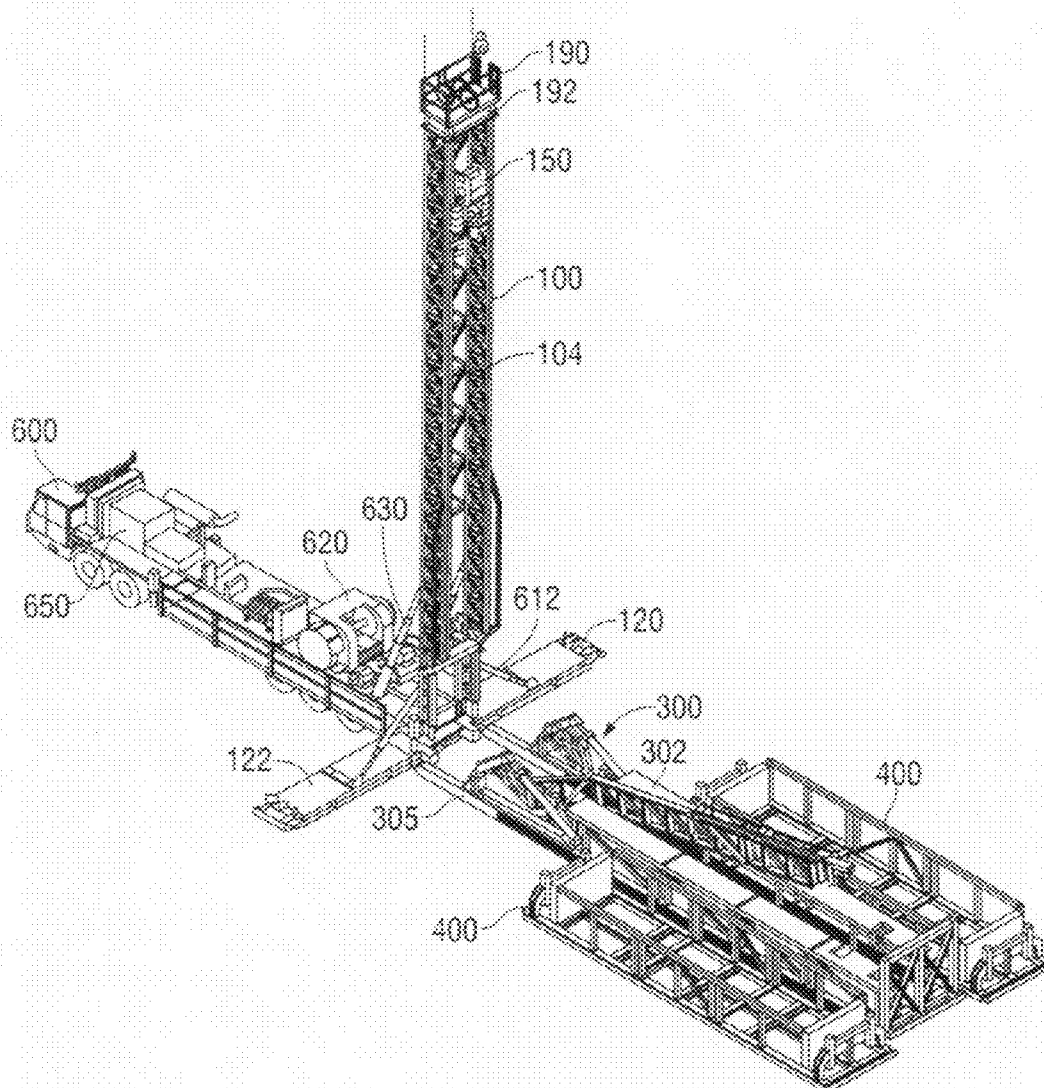
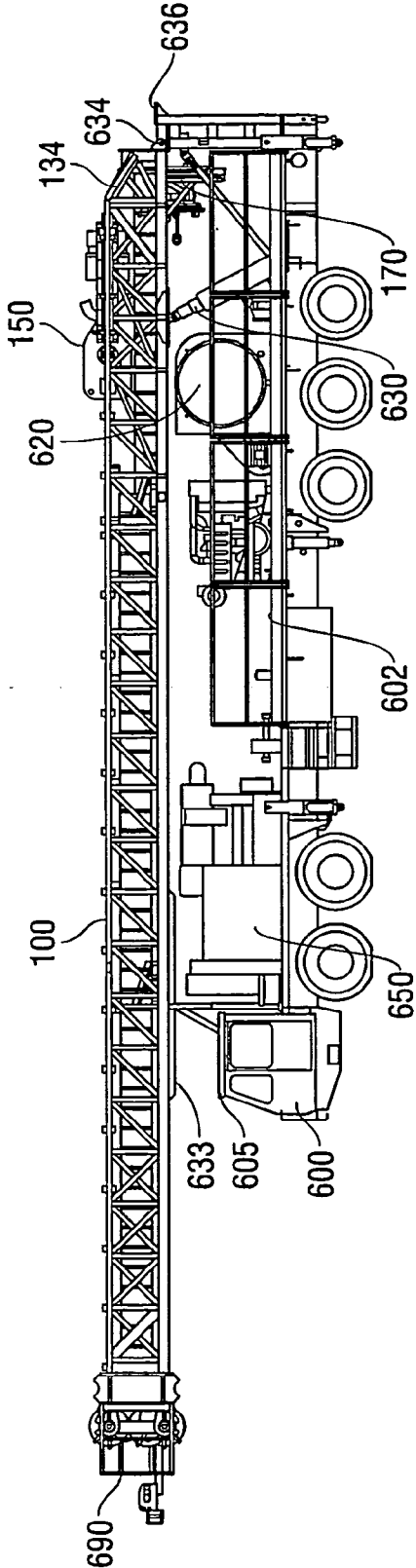
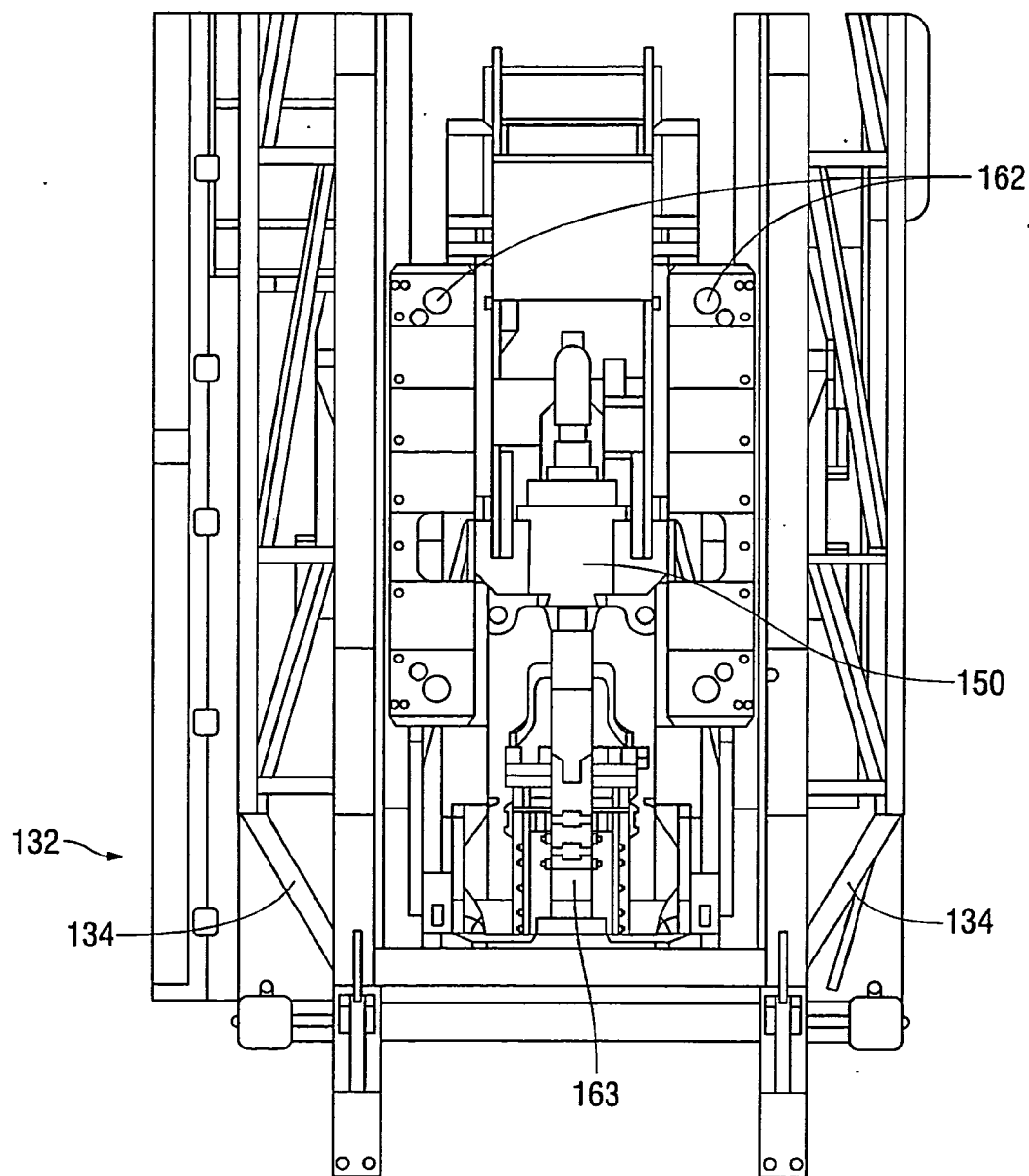

FIG. 2

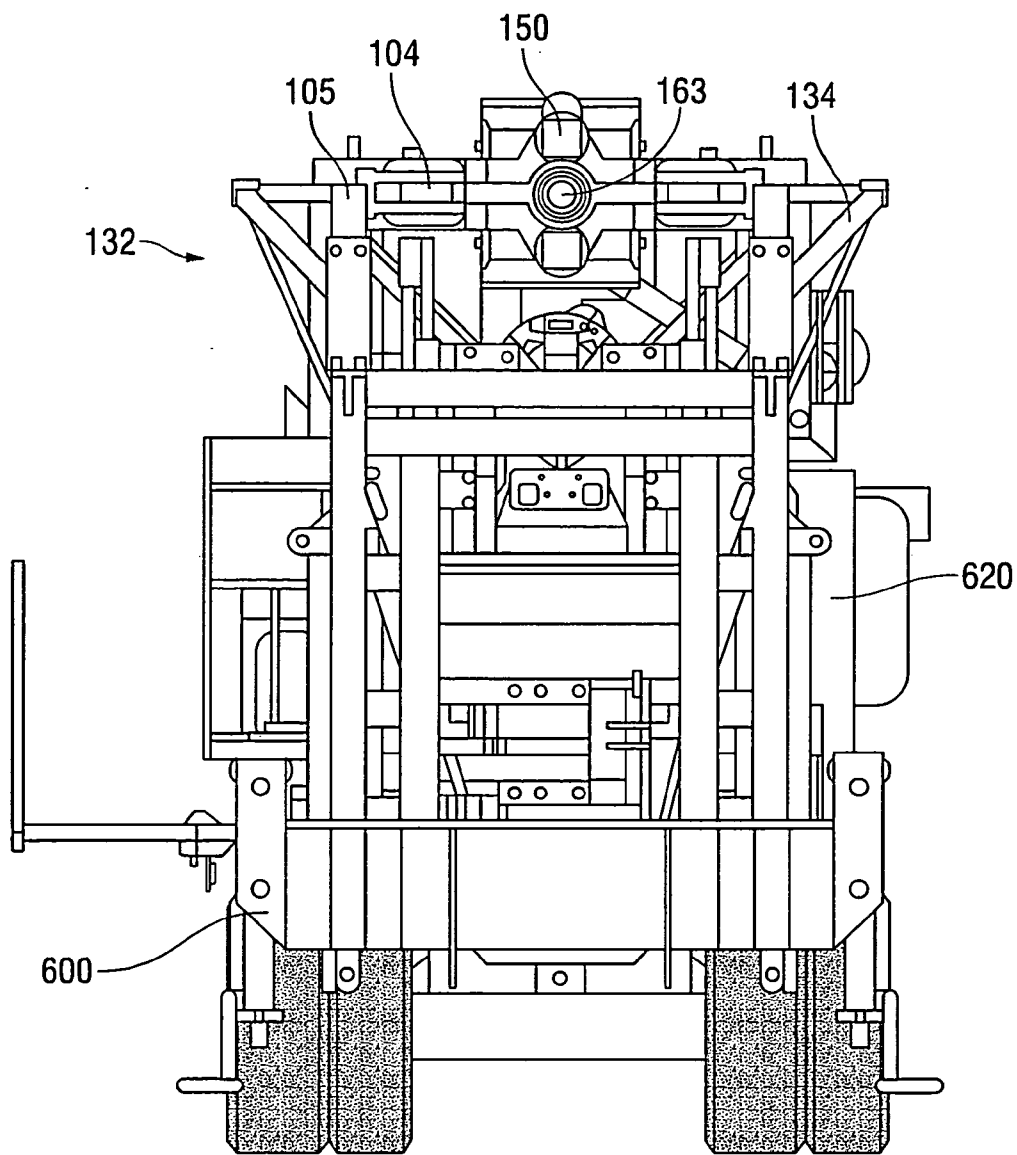



**FIG. 4**



**FIG. 4A-A**



**FIG. 4B-B**

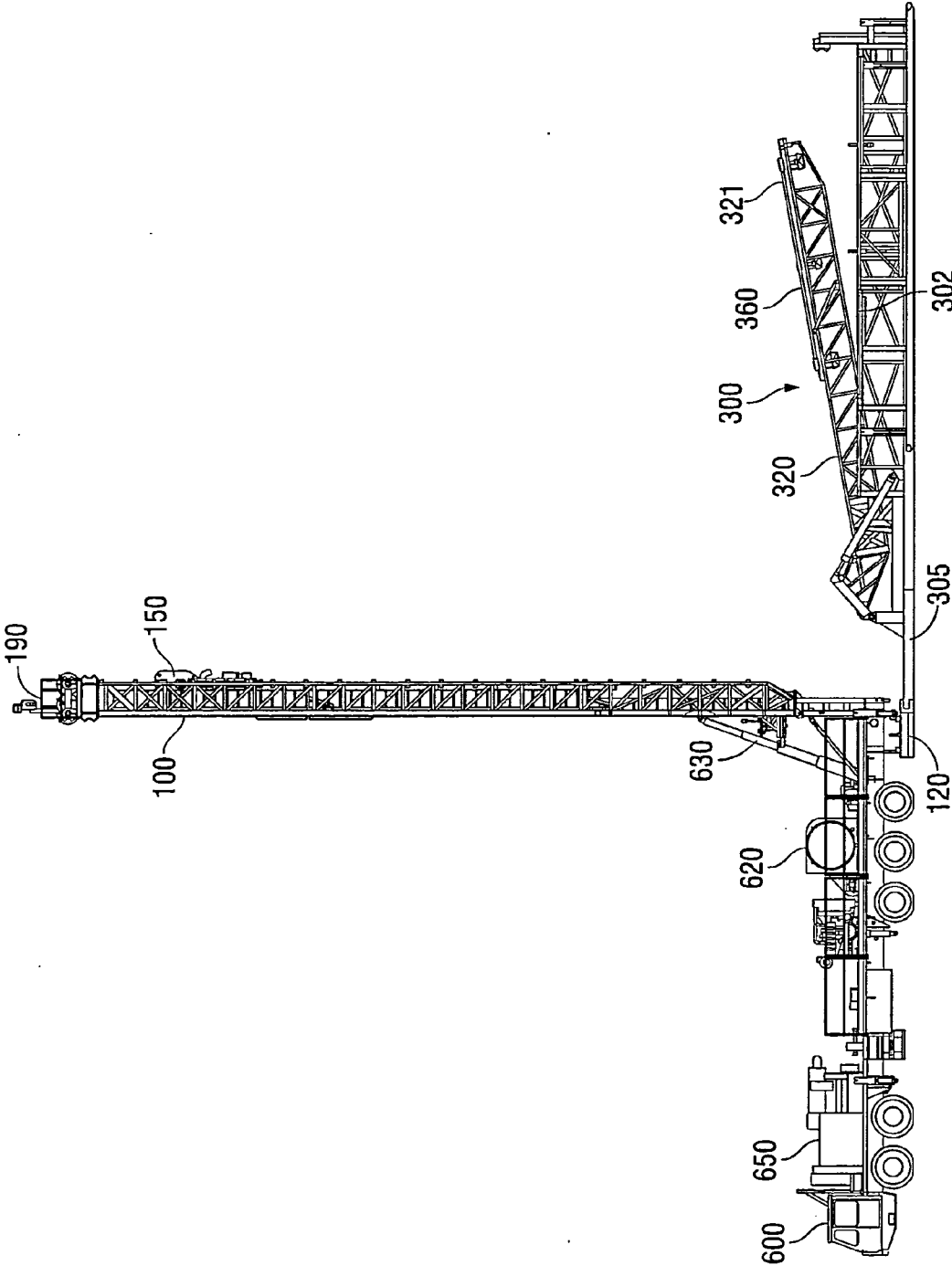
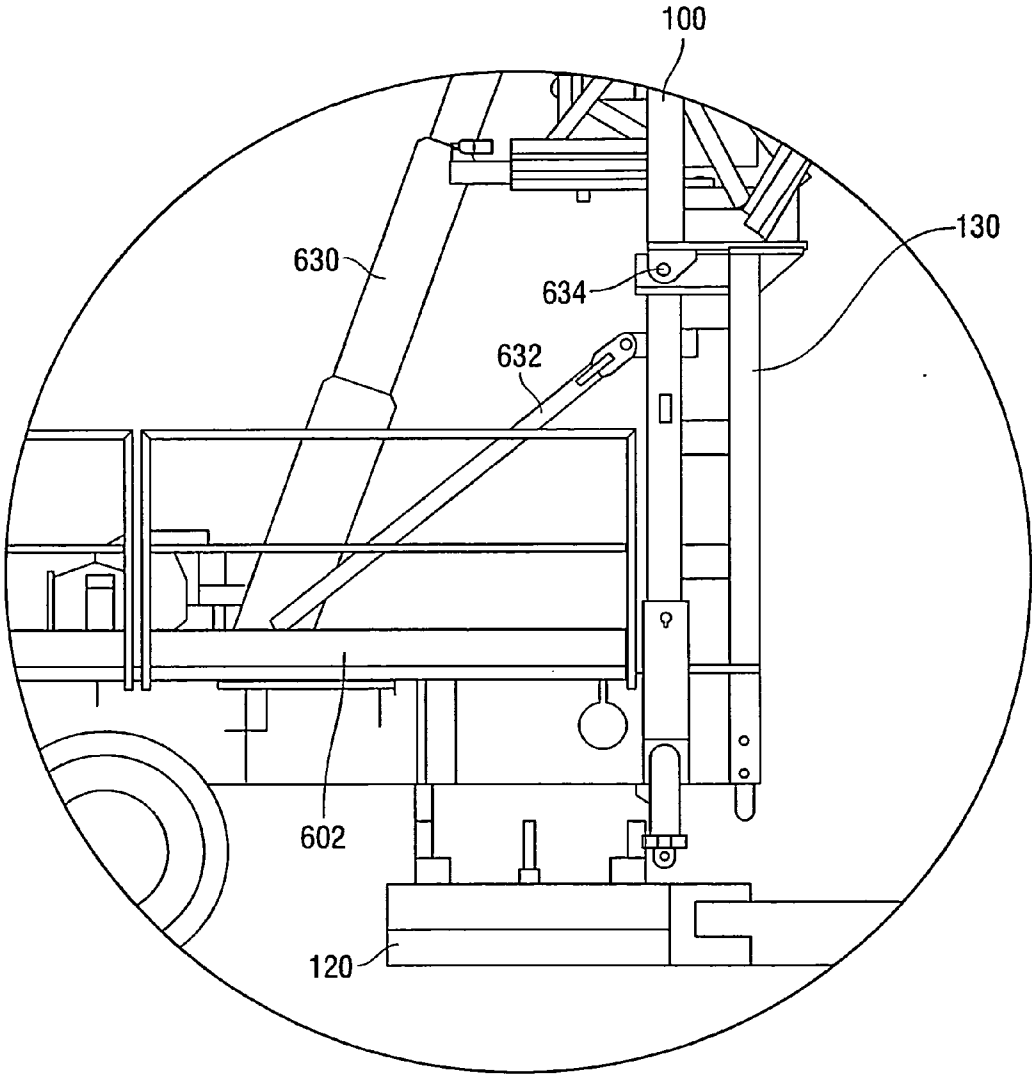

FIG. 5





**FIG. 5A**

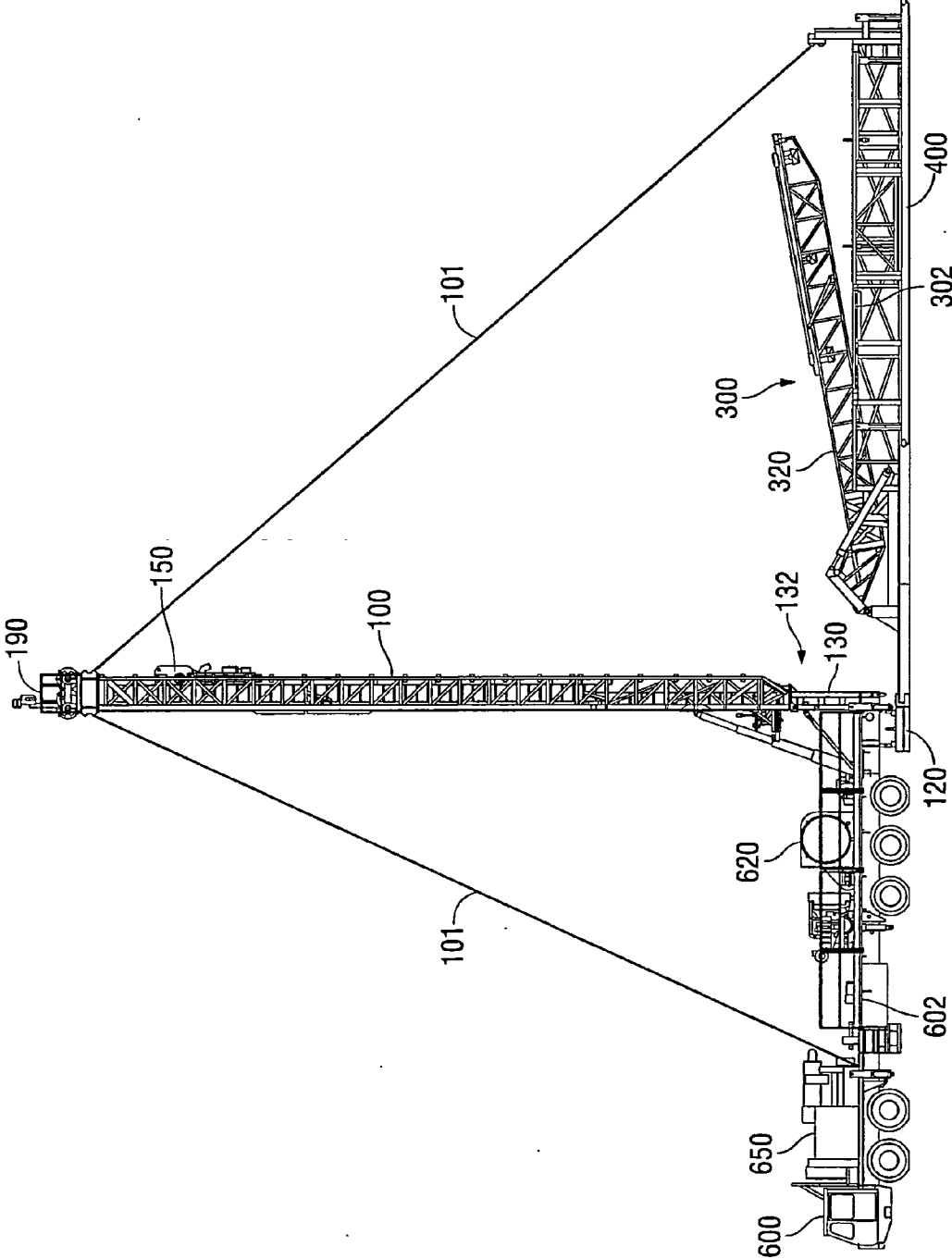
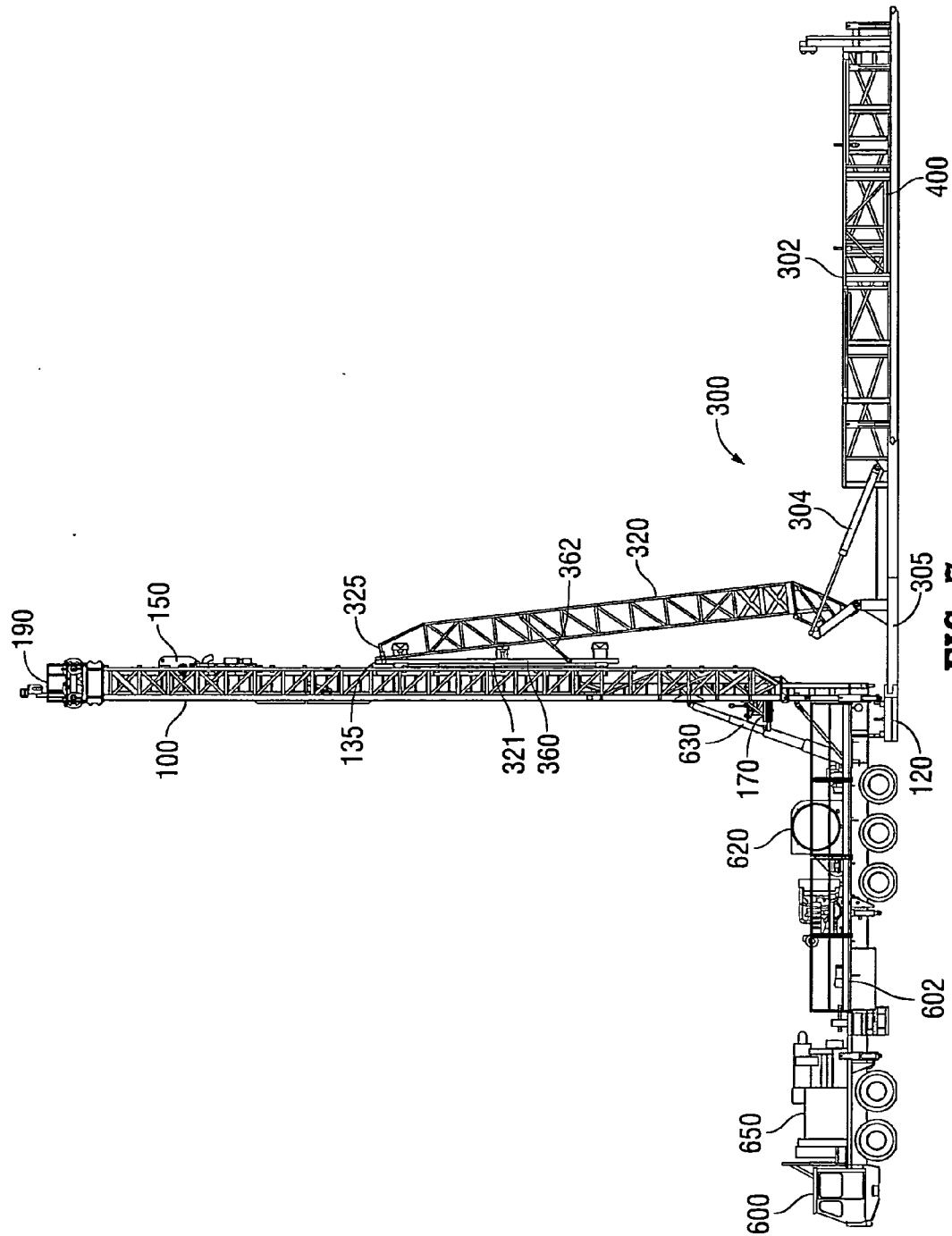
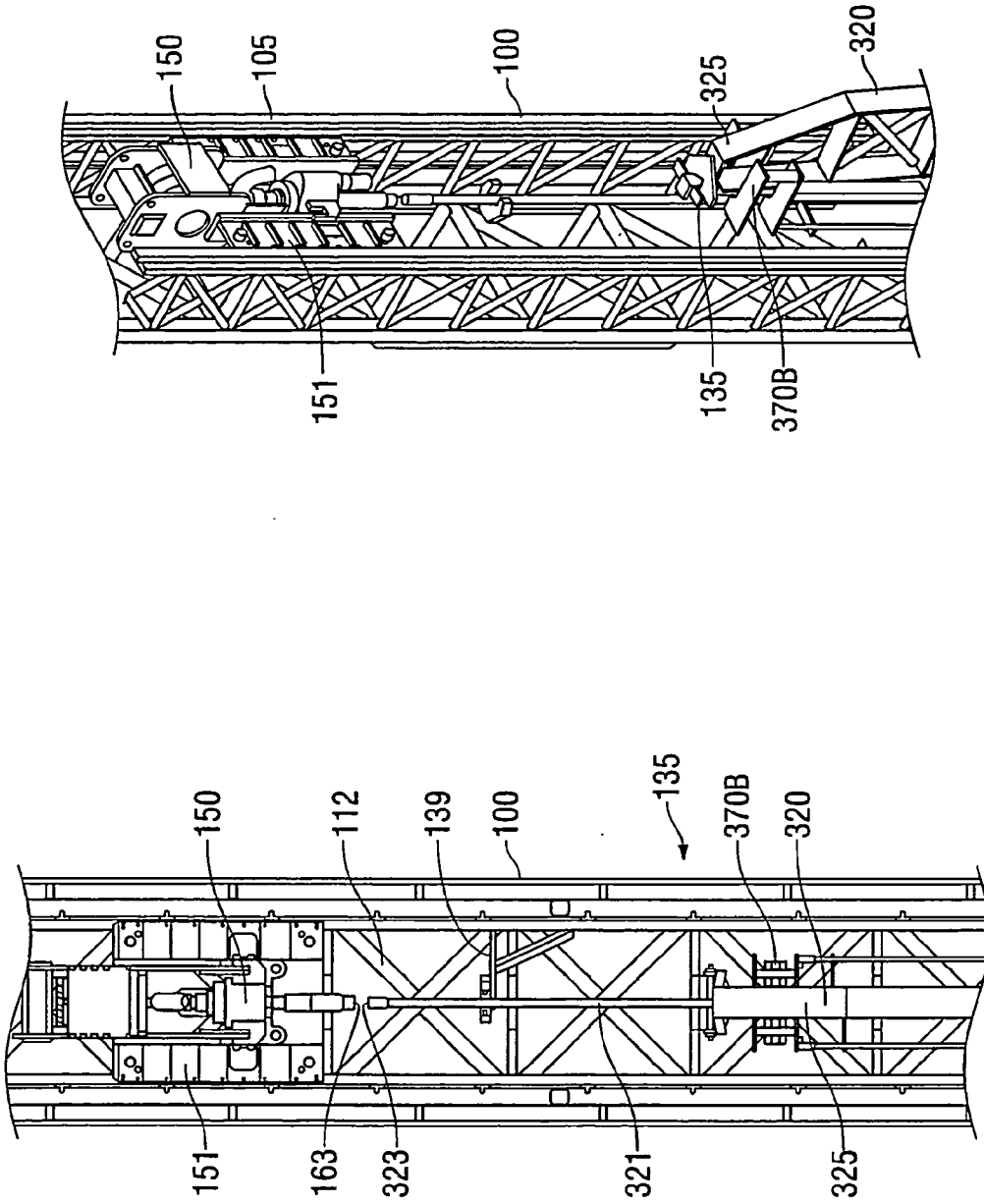

FIG. 6





**FIG. 7**



**FIG. 7B**

**FIG. 7A-A**



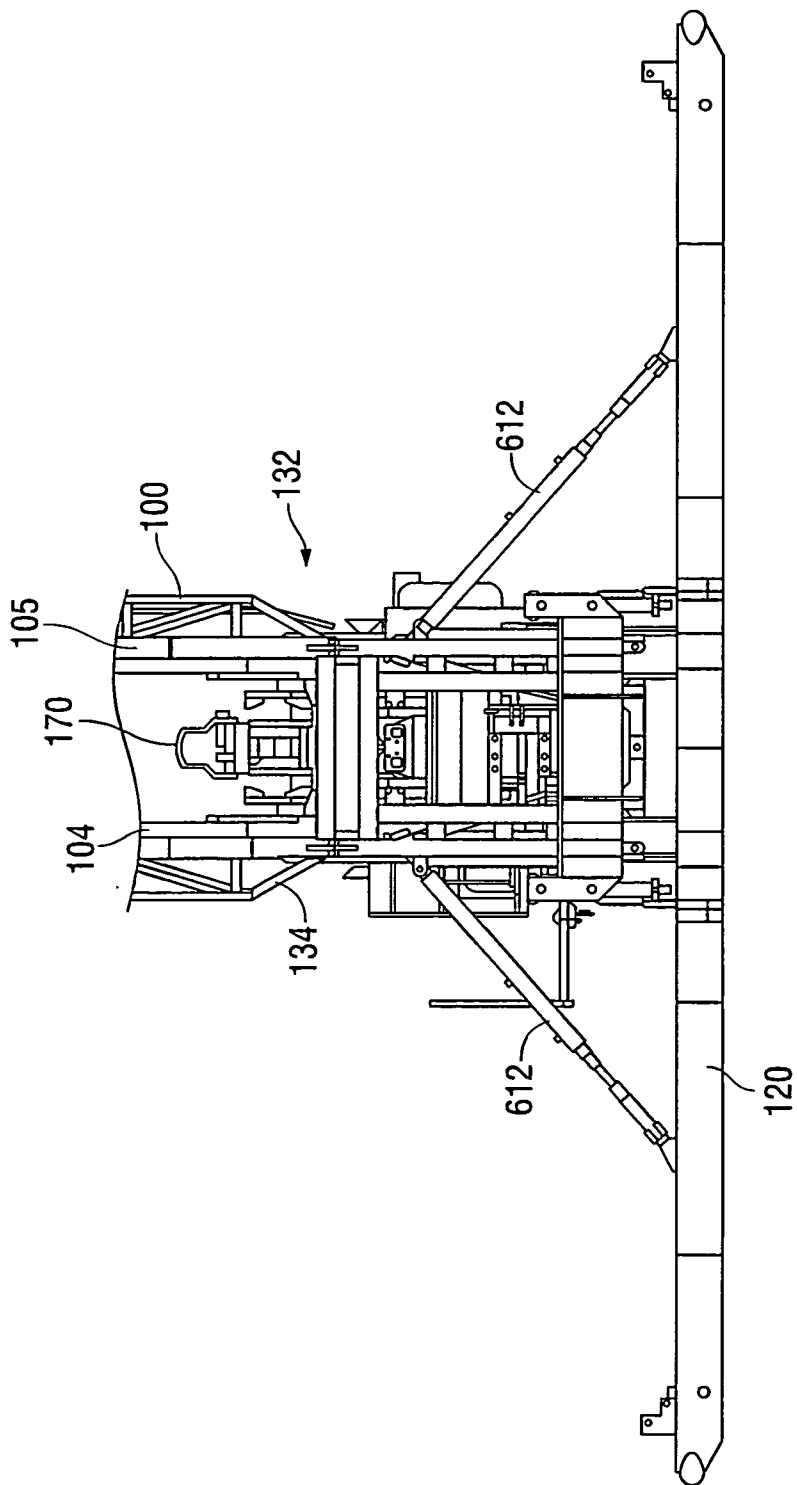

**FIG. 8A-A**

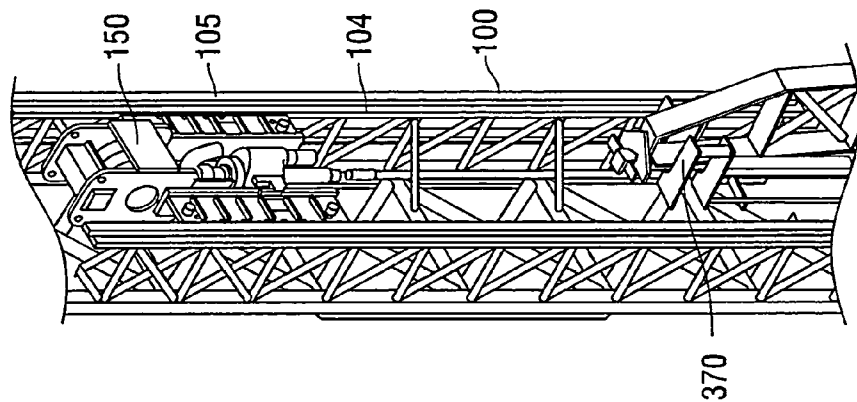

FIG. 8C

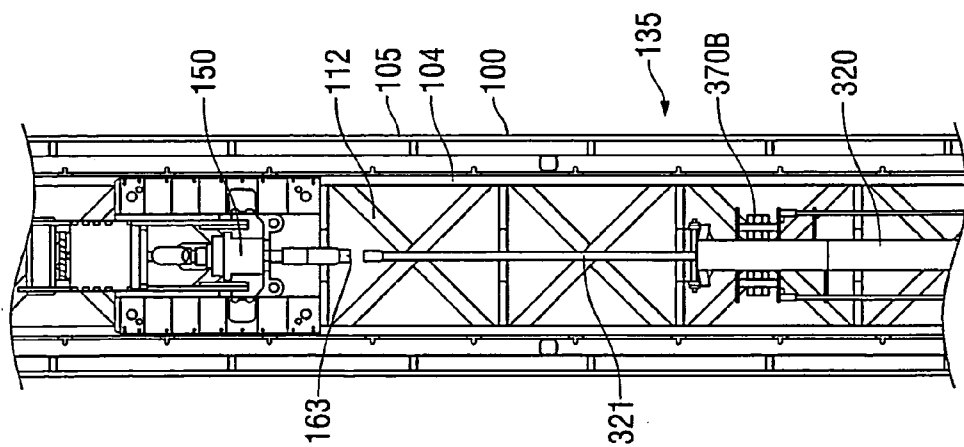

FIG. 8B-B



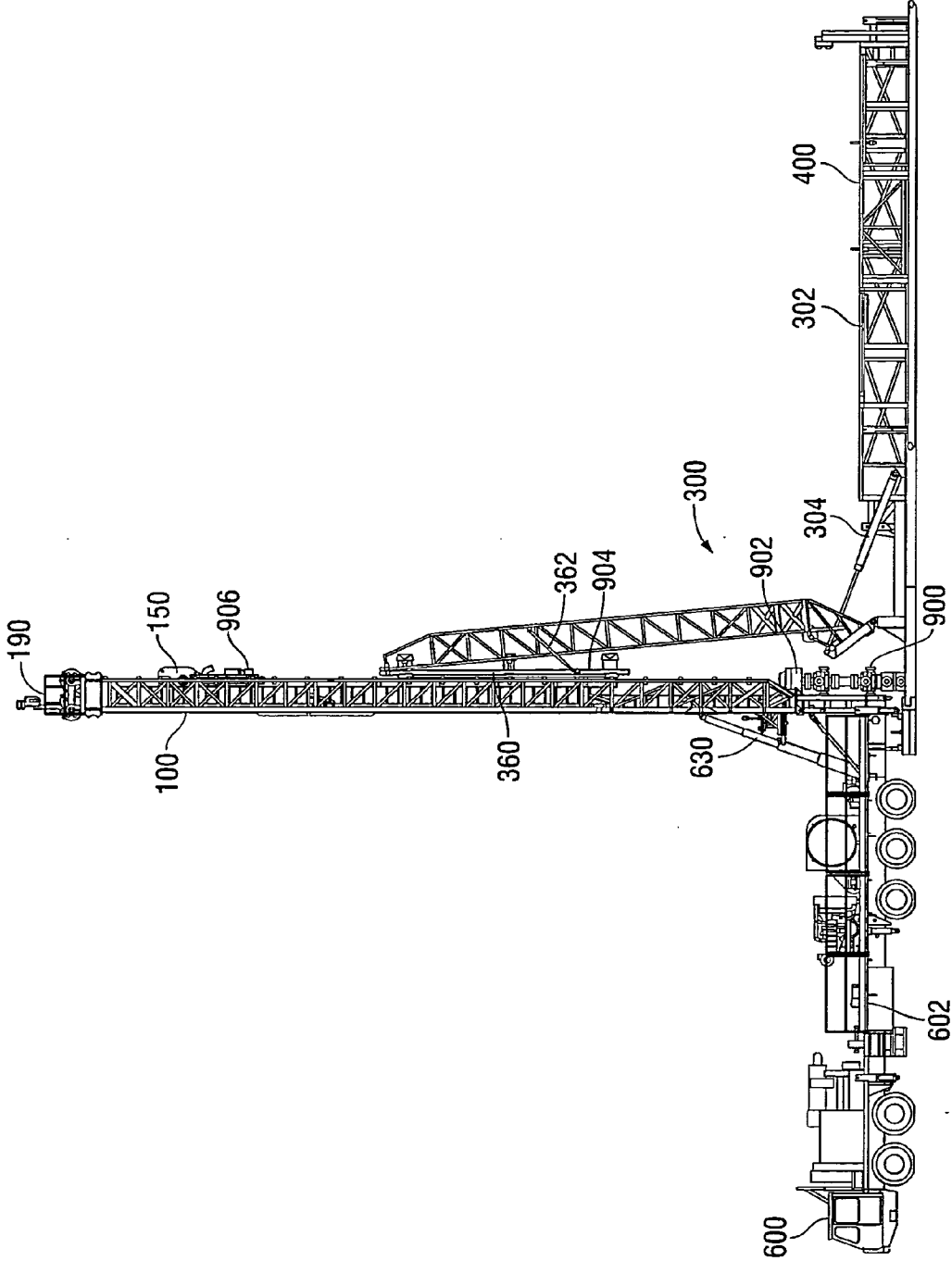
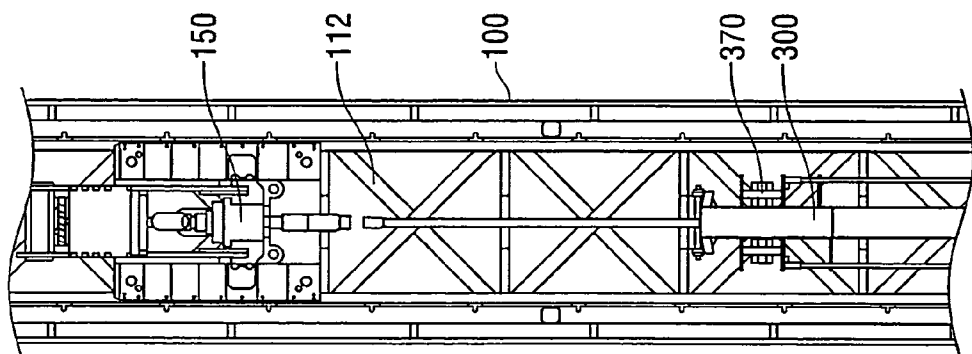
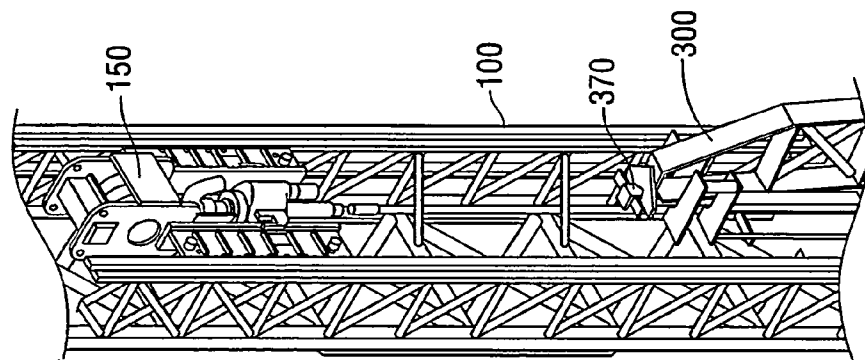

FIG. 9



**FIG. 9A-A**



**FIG. 9B-B**

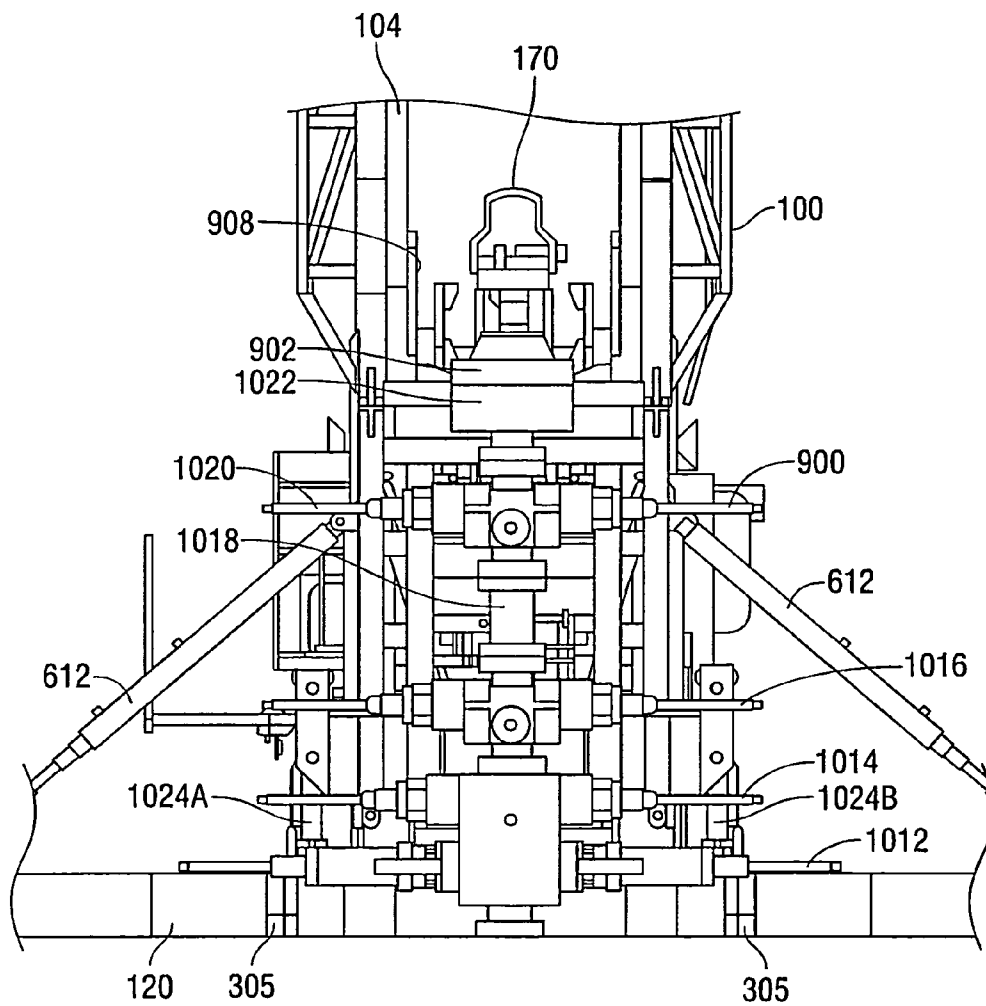

**FIG. 9C-C**

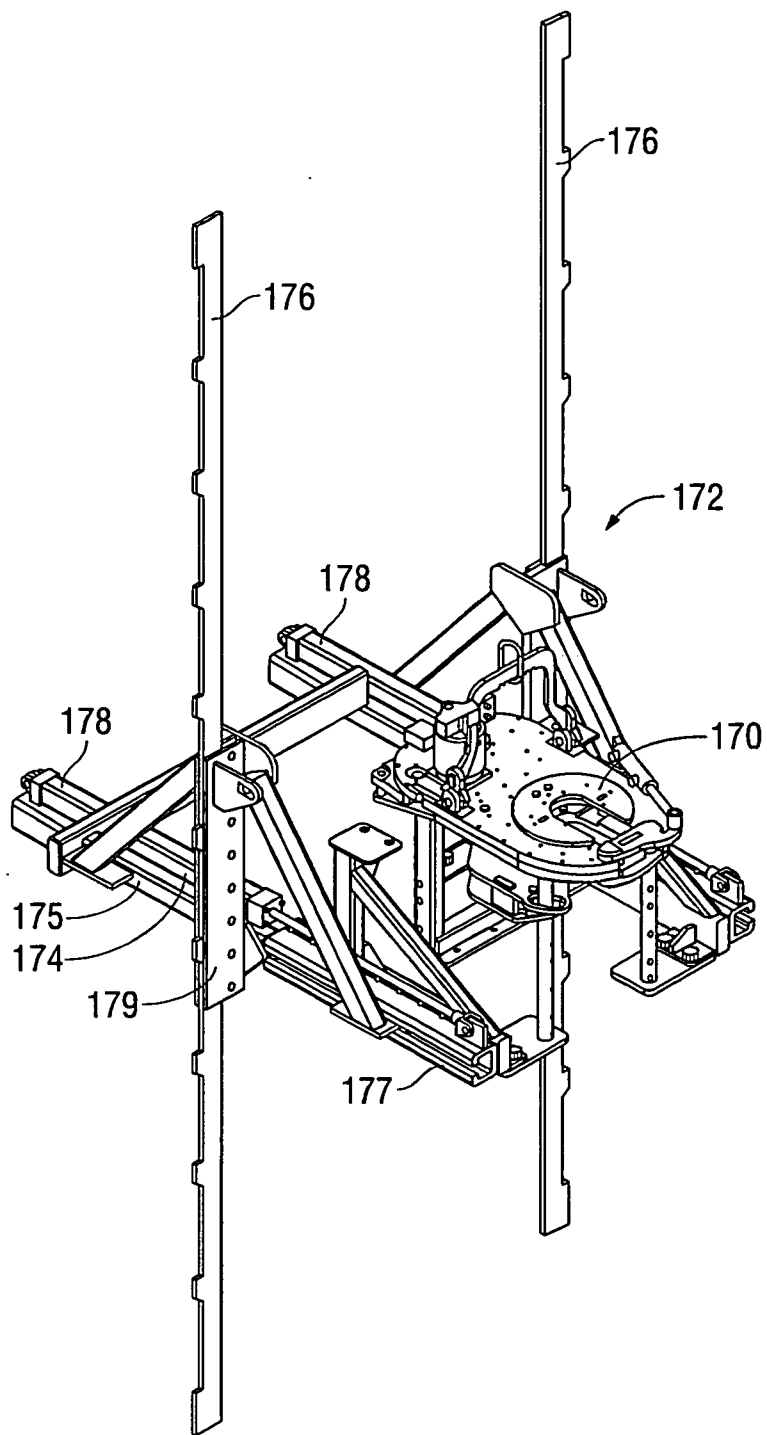

**FIG. 10A**

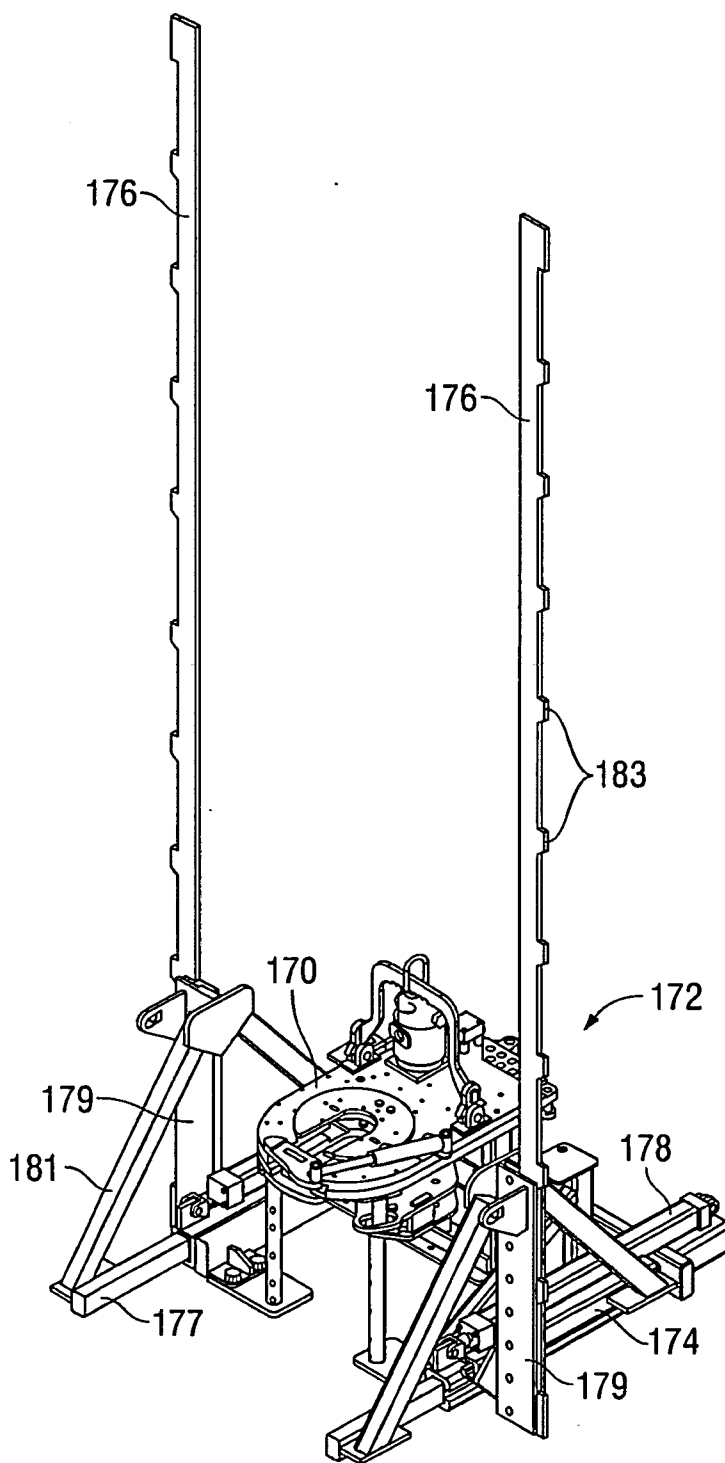

**FIG. 10B**

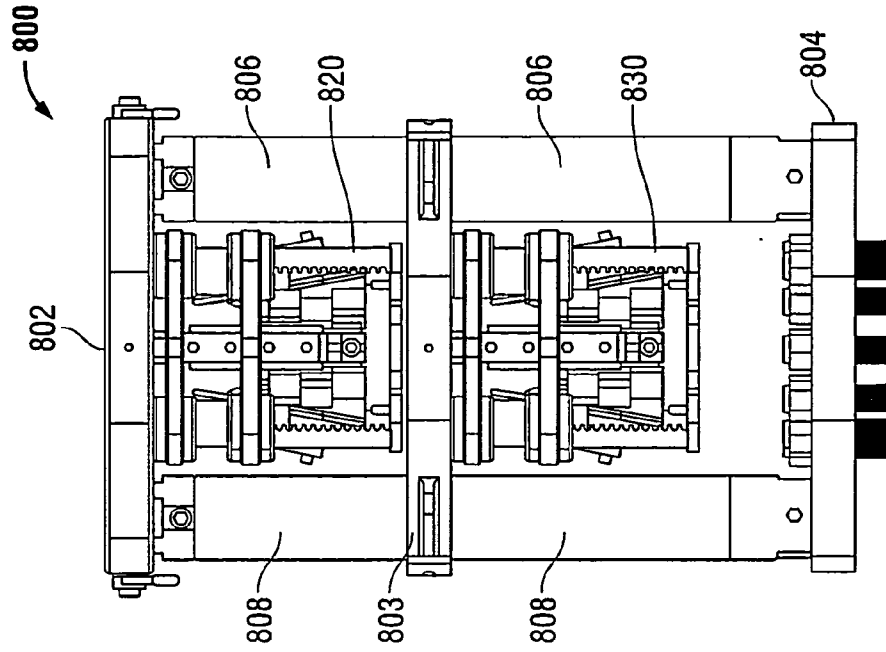

FIG. 11A

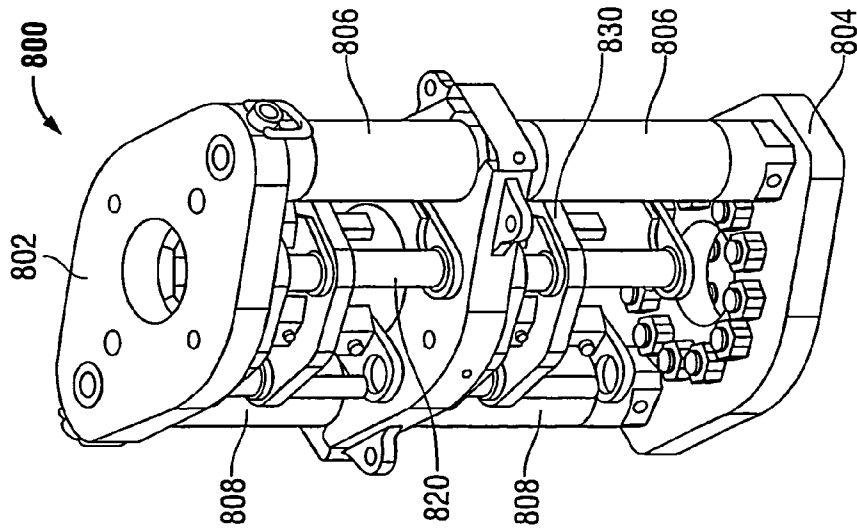

FIG. 11B

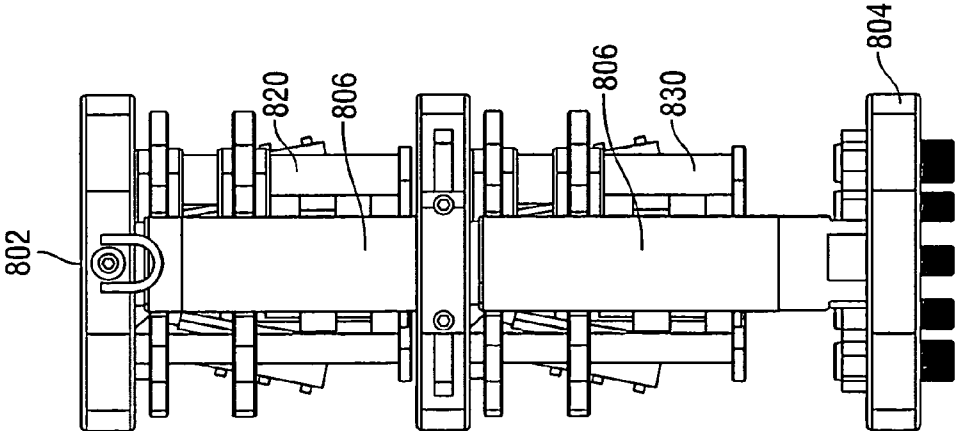

FIG. 11C

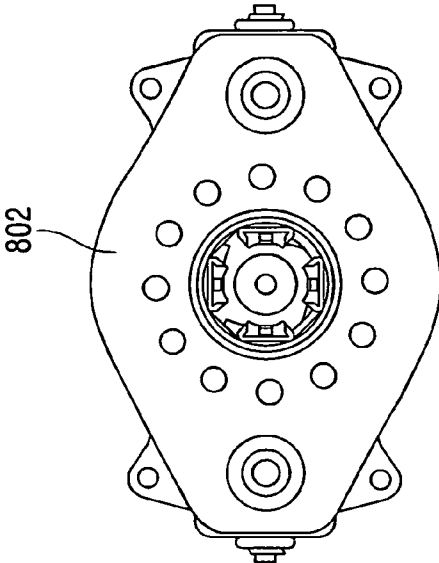

FIG. 11D

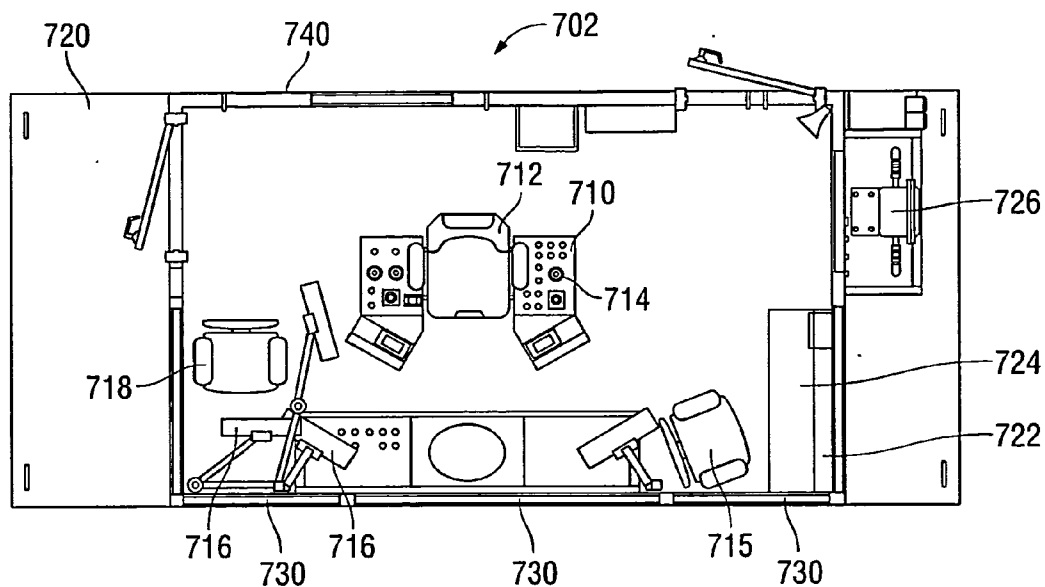

FIG. 12A

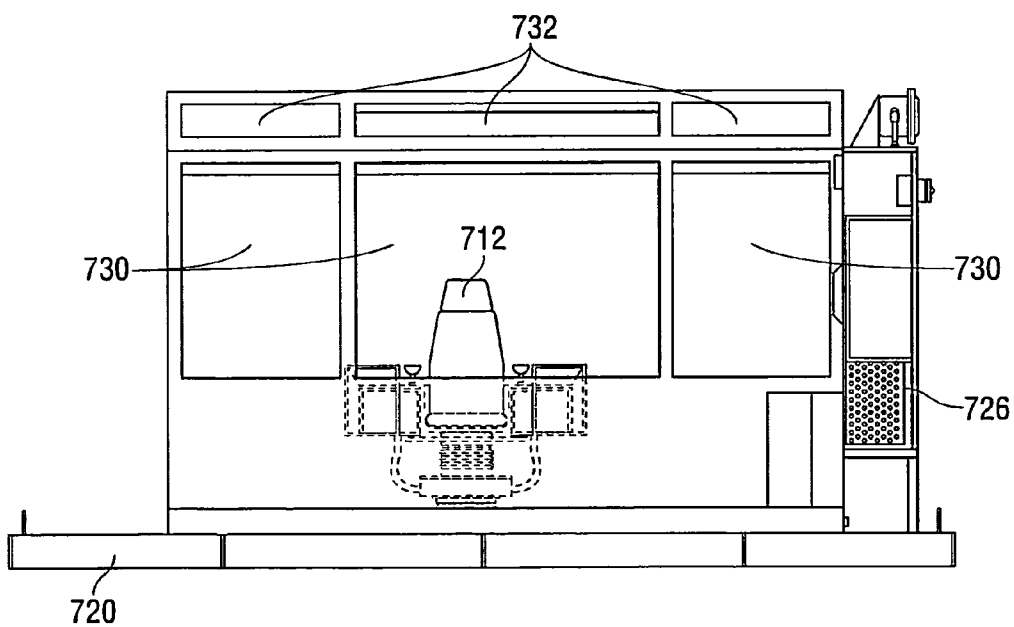
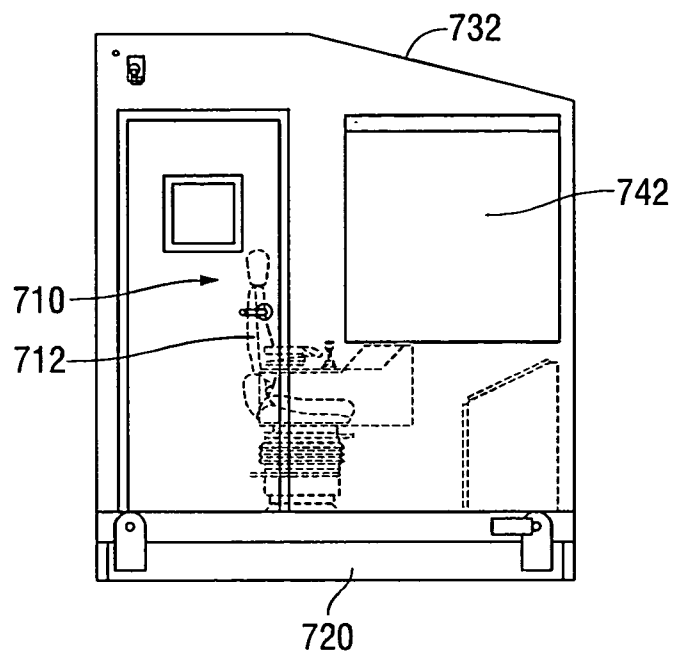
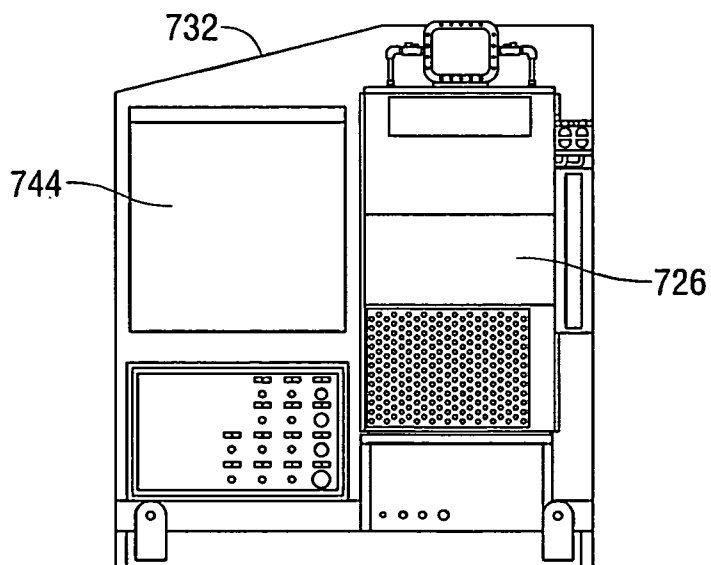

FIG. 12B





**FIG. 12C**



**FIG. 12D**

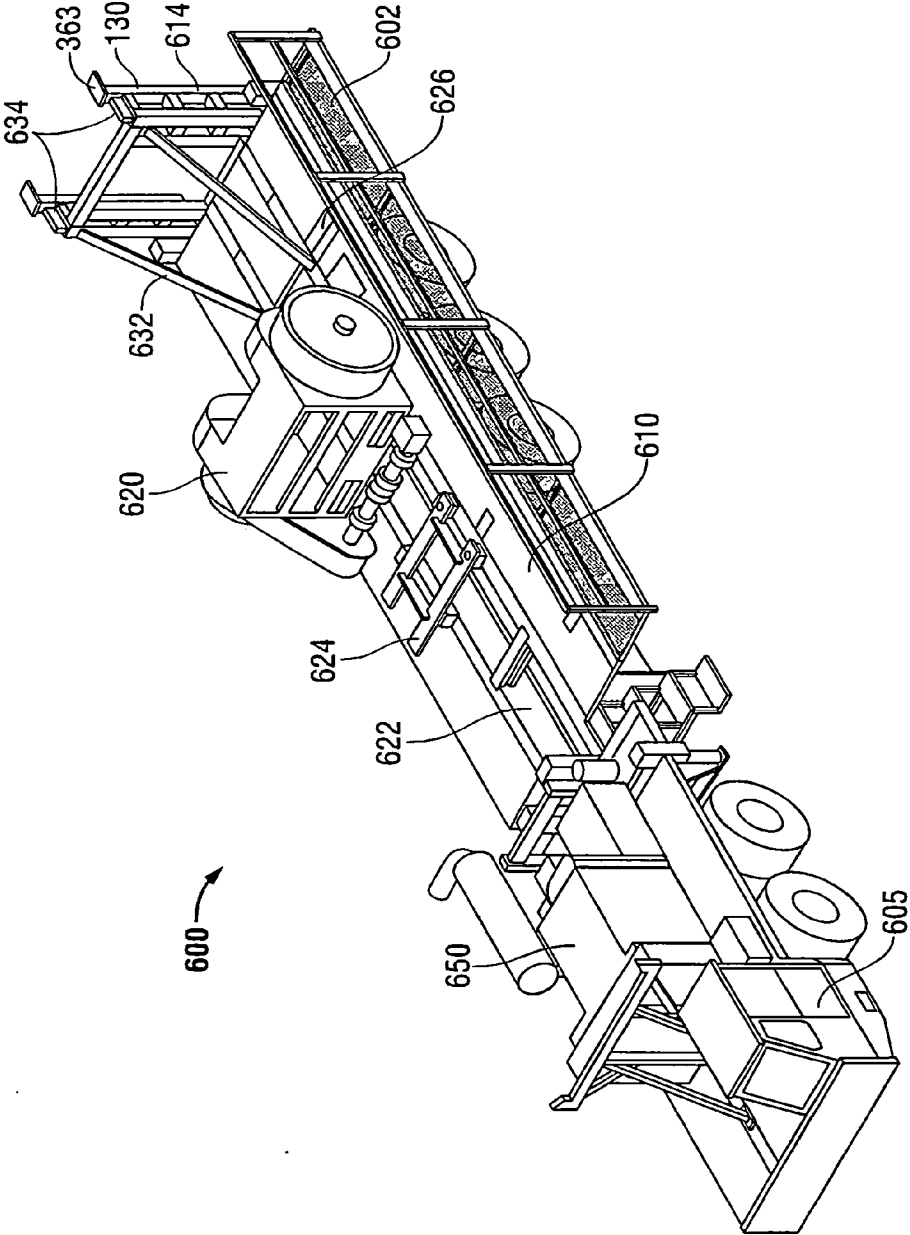
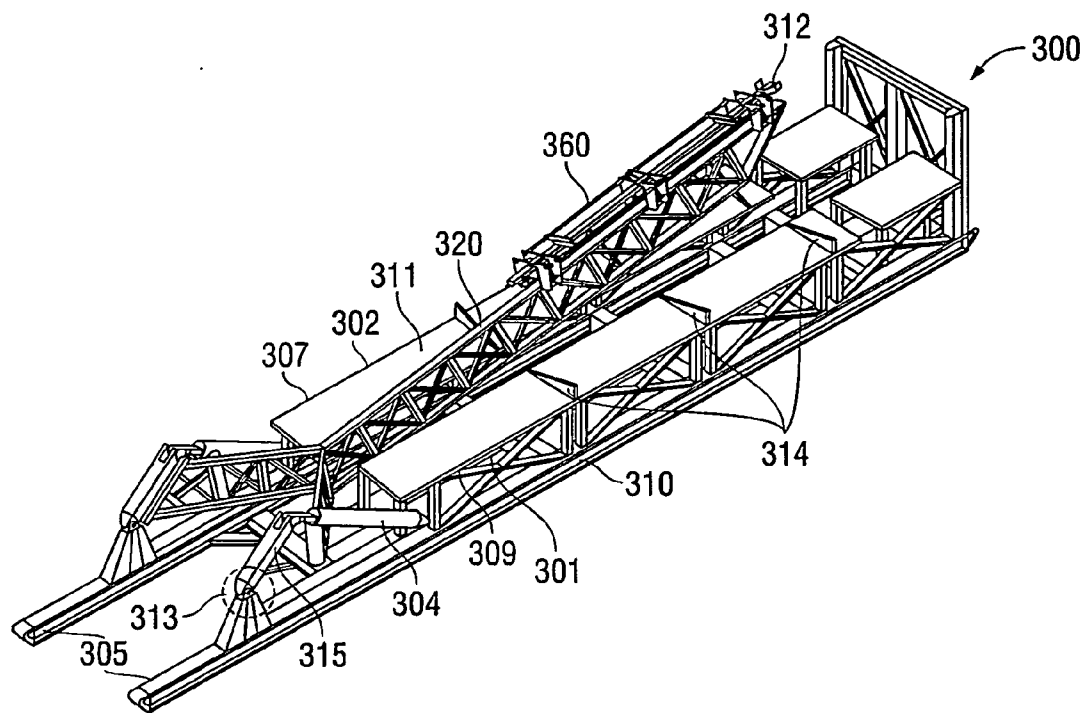
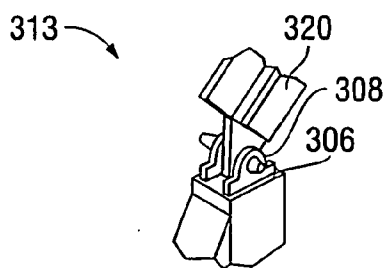

FIG. 13



**FIG. 14**



**FIG. 14A**

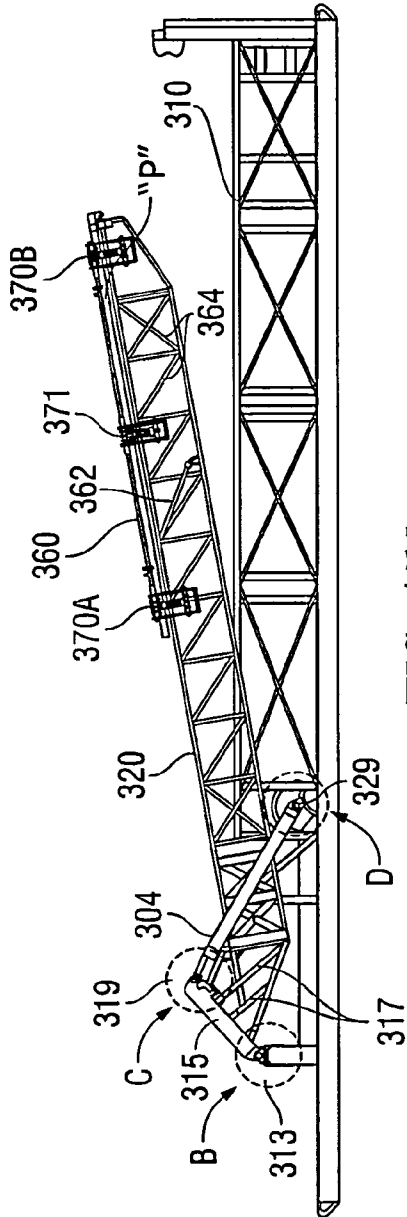

**FIG. 15A**

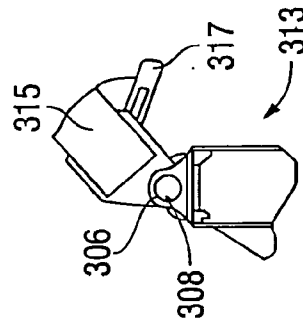

**FIG. 15B**

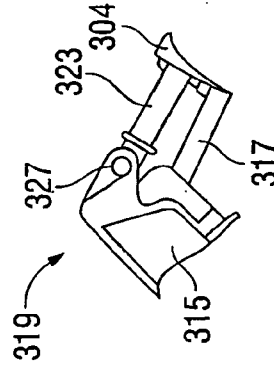

**FIG. 15C**

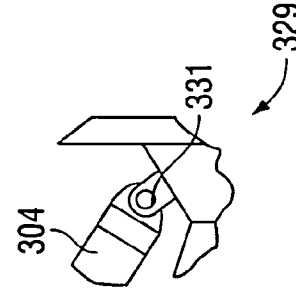

**FIG. 15D**

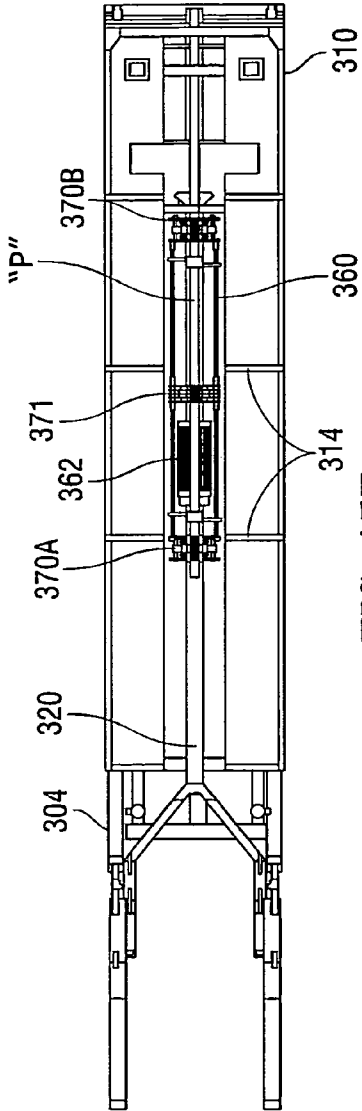

**FIG. 15E**

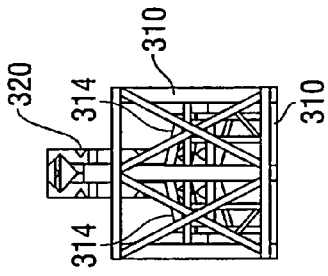

**FIG. 15G**

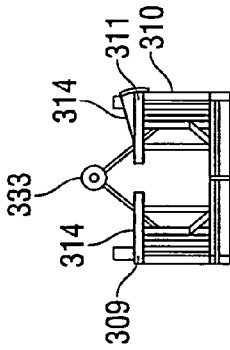

**FIG. 15F**

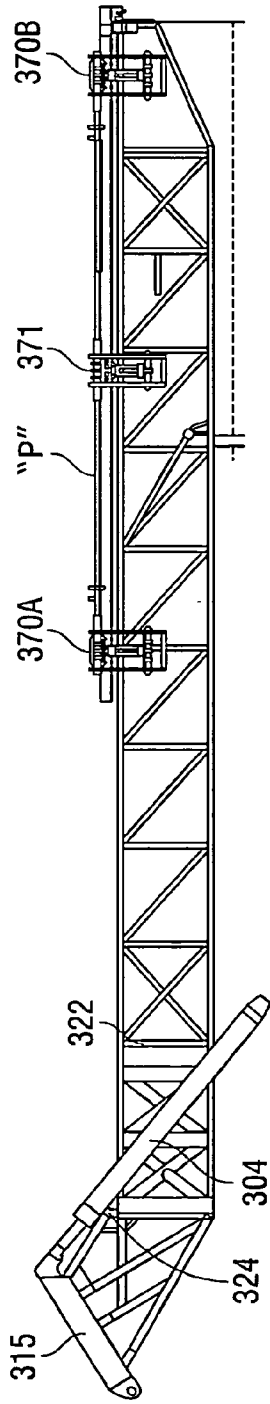

FIG. 16A

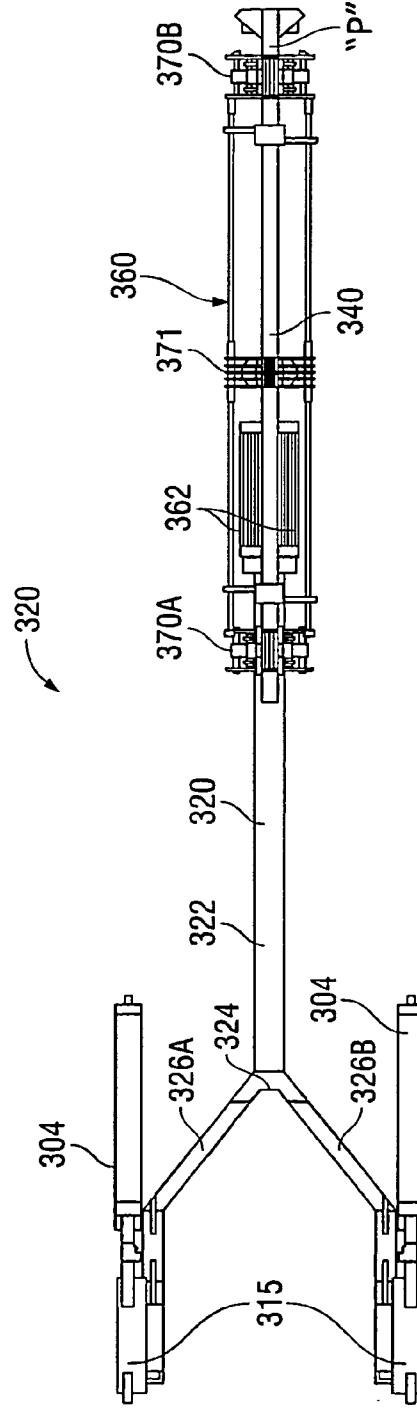
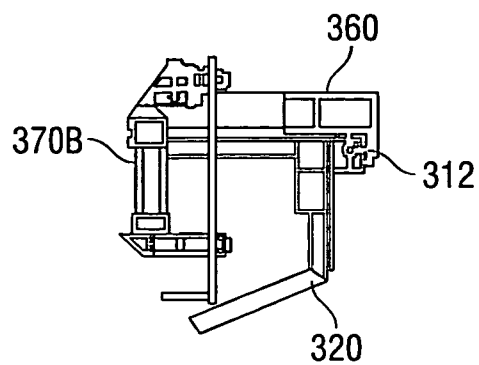
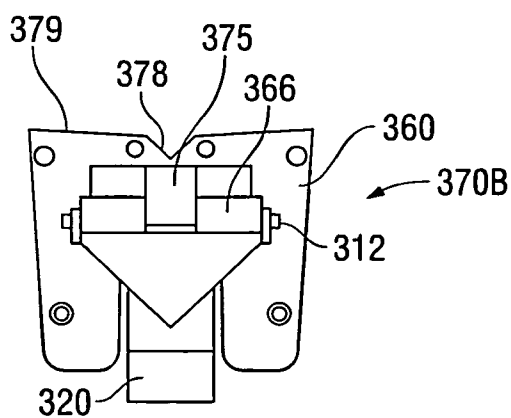

FIG. 16B



**FIG. 16C**



**FIG. 16D**

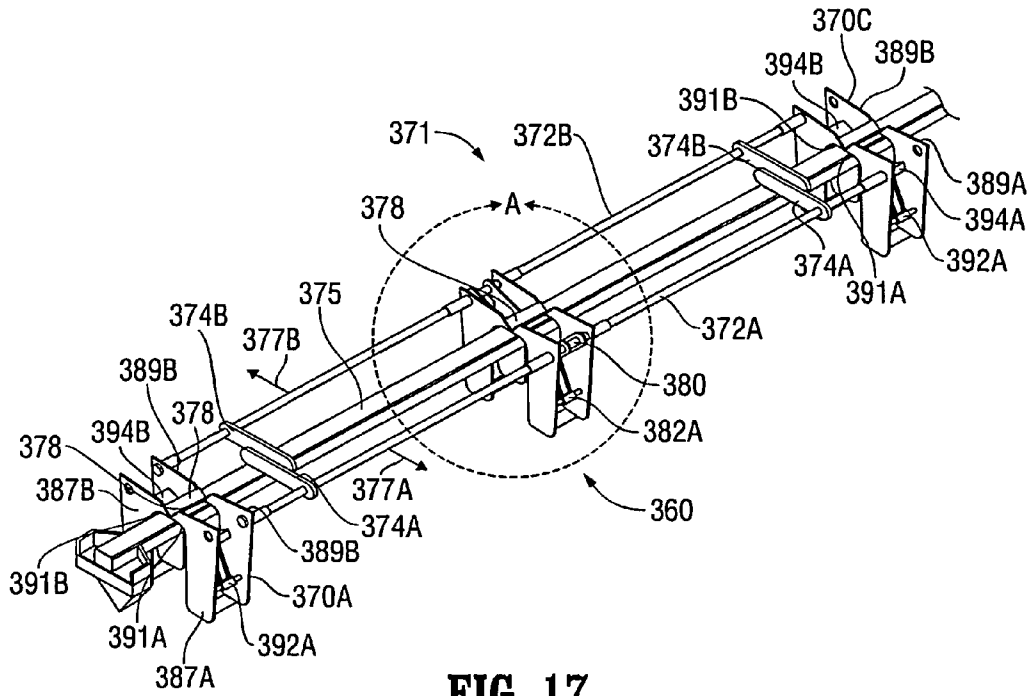

FIG. 17

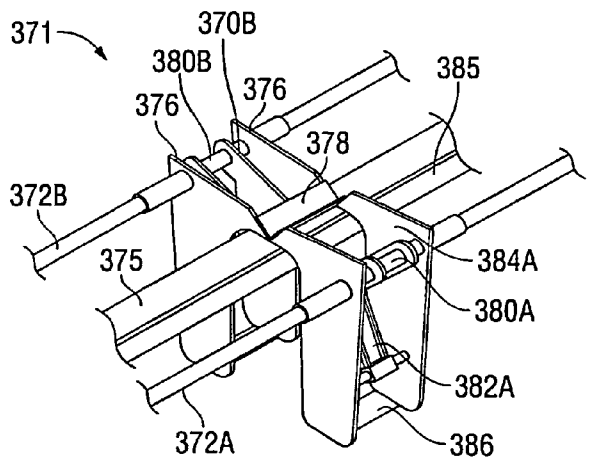
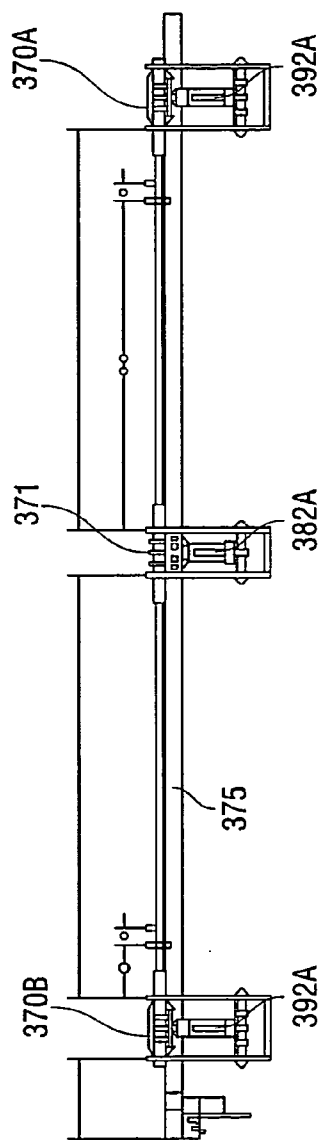
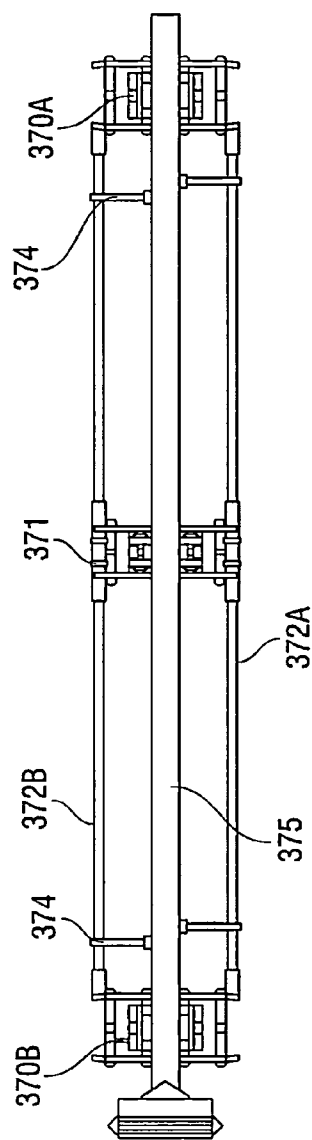

FIG. 17A

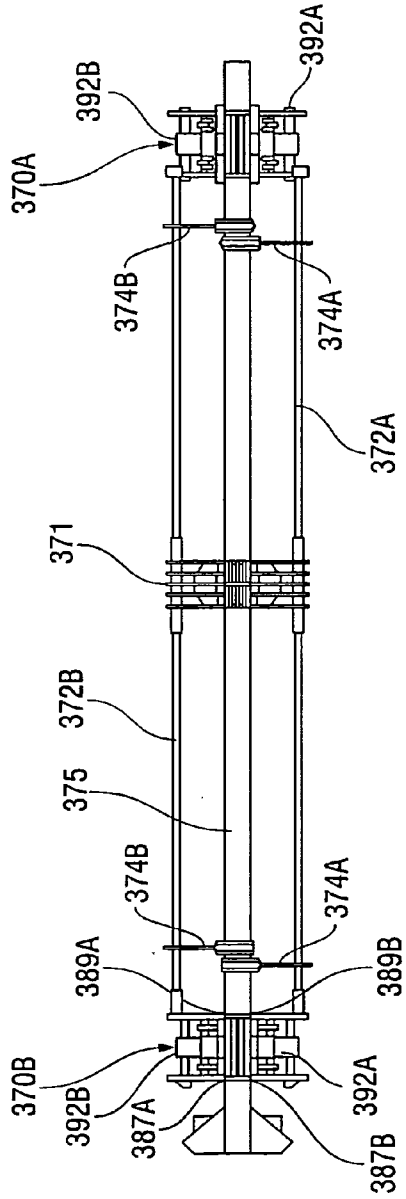



**FIG. 18A**



**FIG. 18B**



**FIG. 18C**

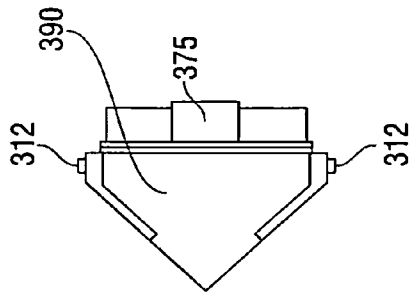

**18B-B**

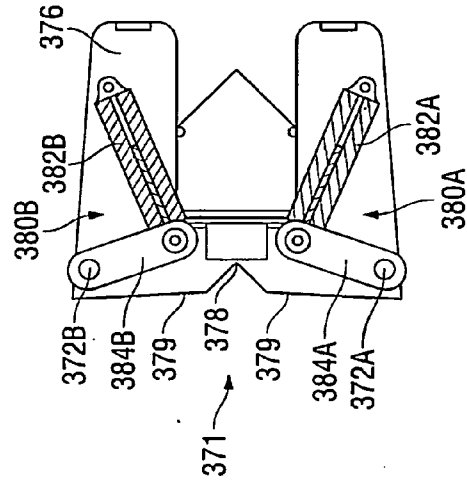

**18C-C**

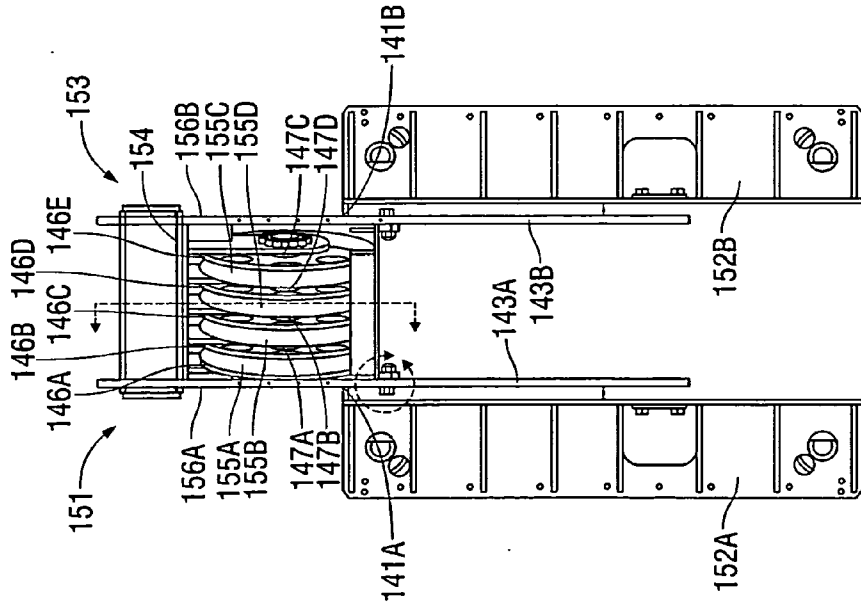

FIG. 19A

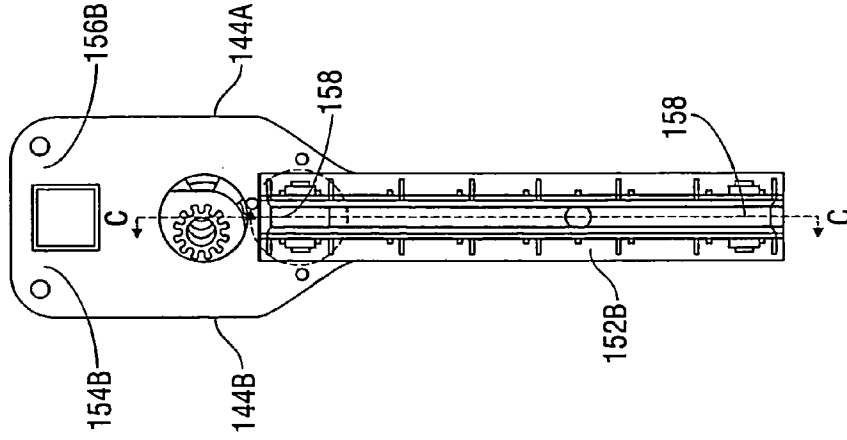
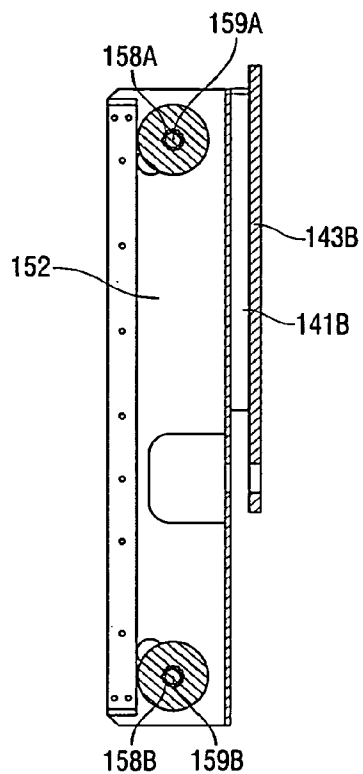
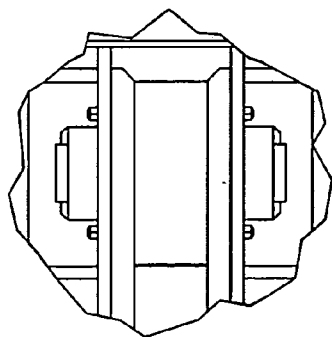

FIG. 19B



**FIG. 19C-C**



**FIG. 19D**

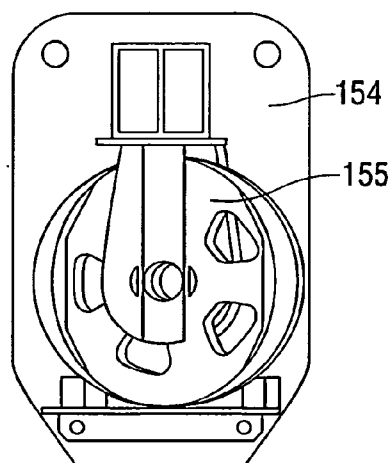

**FIG. 19E-E**

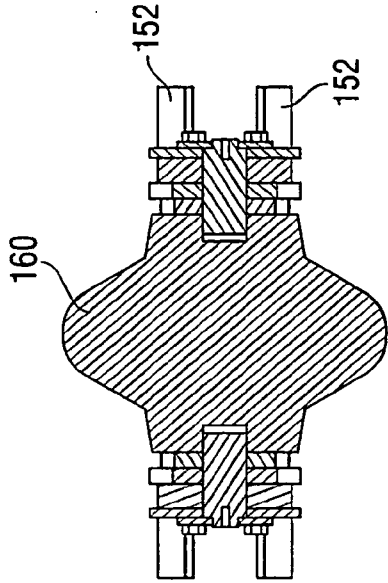

**FIG. 20 A-A**

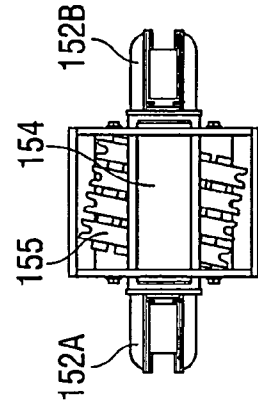

**FIG. 20 B**

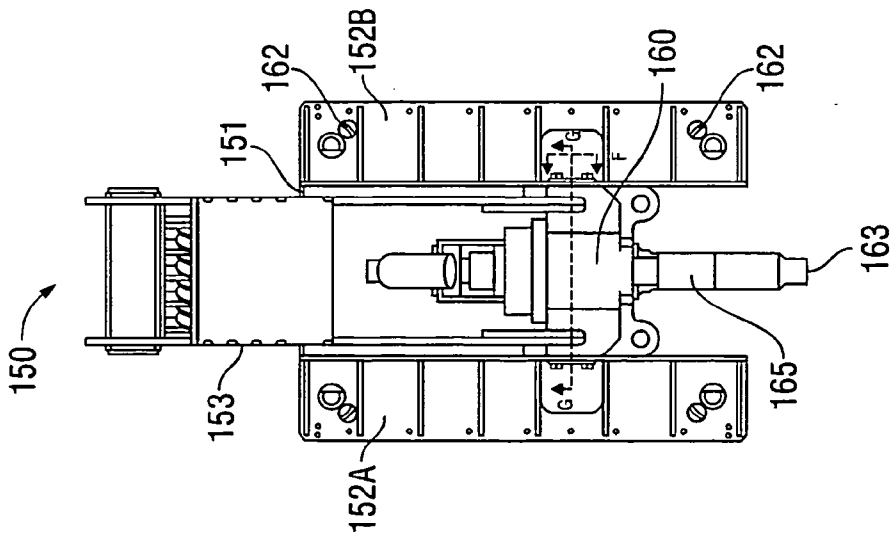

**FIG. 20 A**

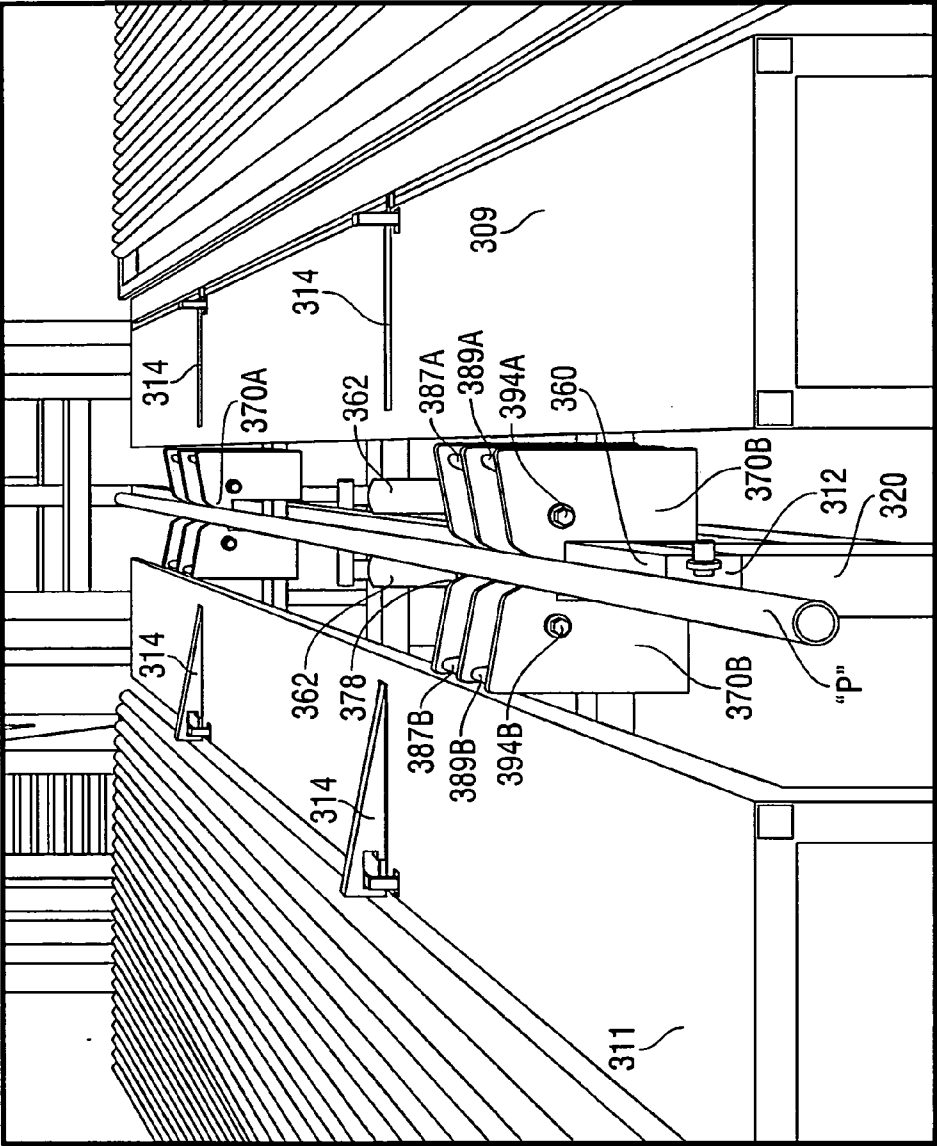

FIG. 21A

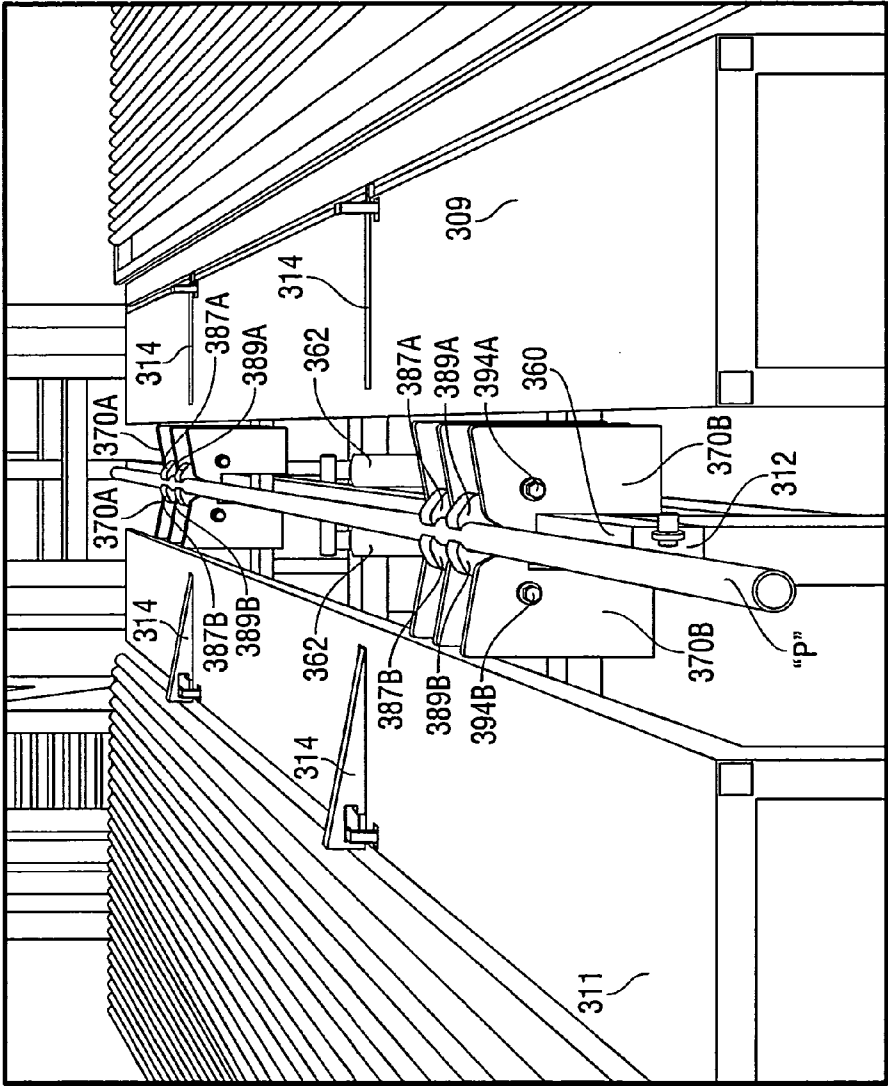

FIG. 21B

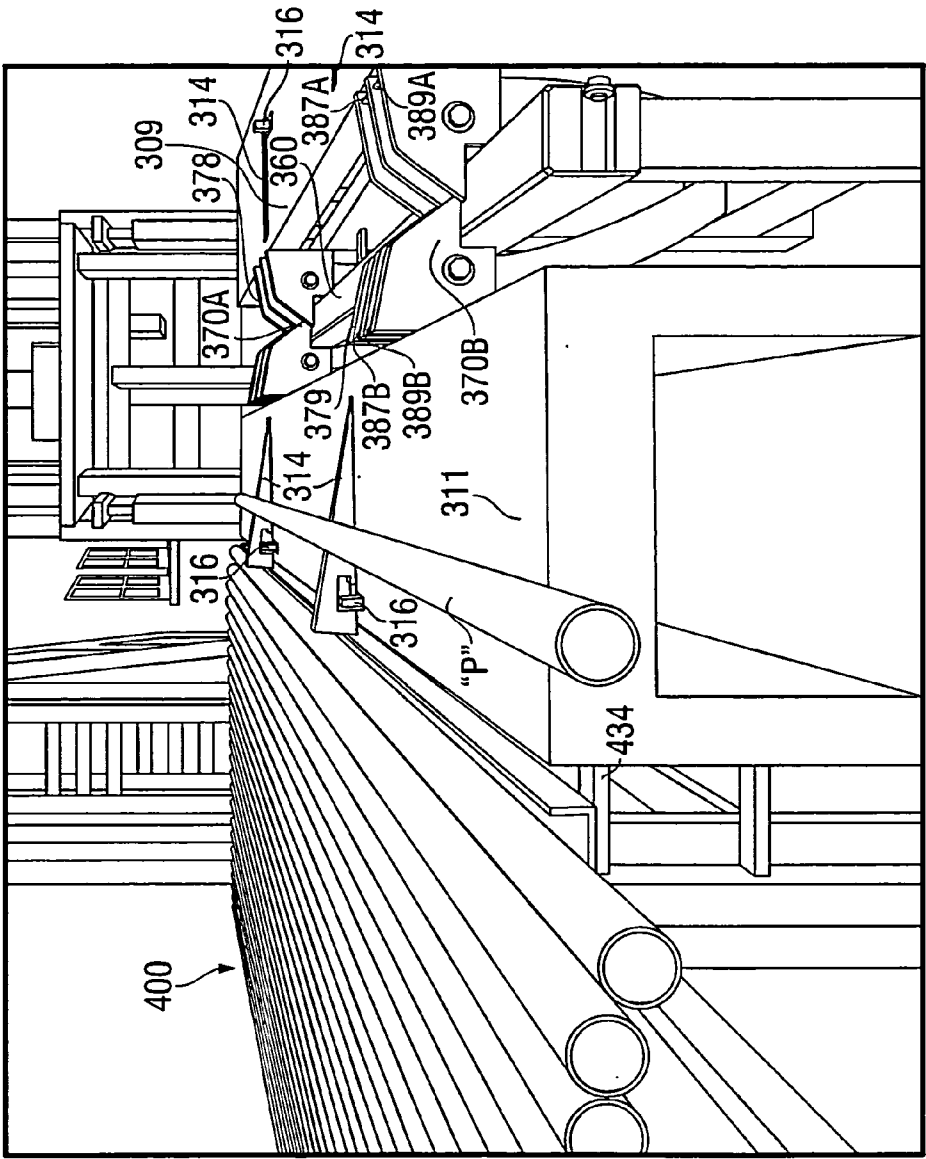

FIG. 22A



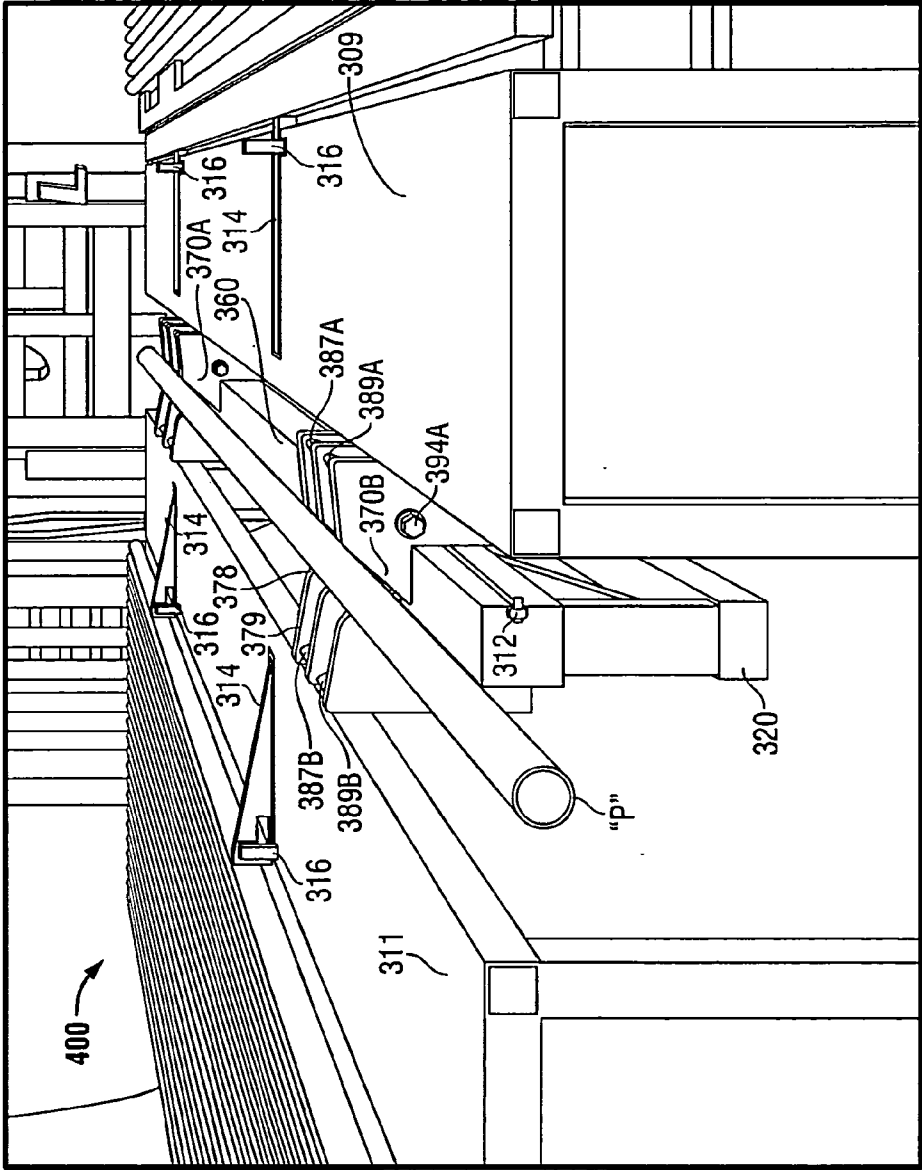

FIG. 22B

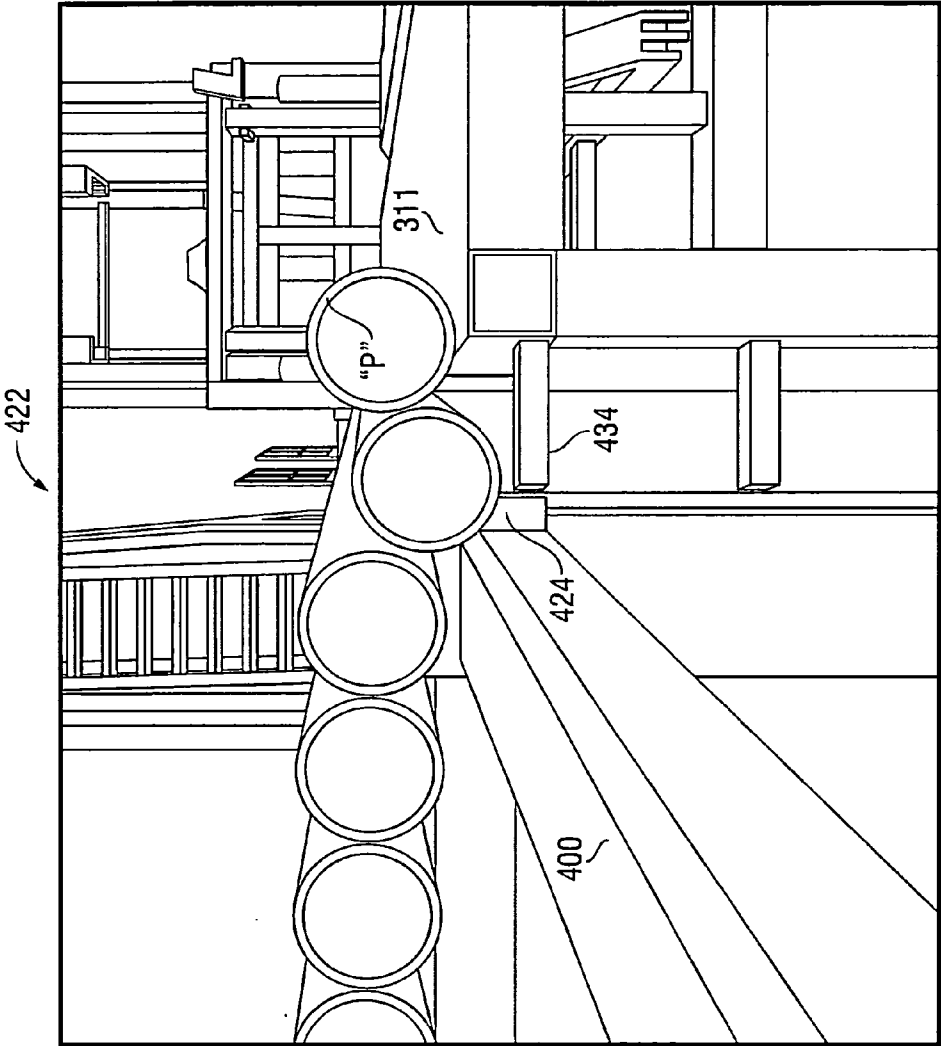

FIG. 23A

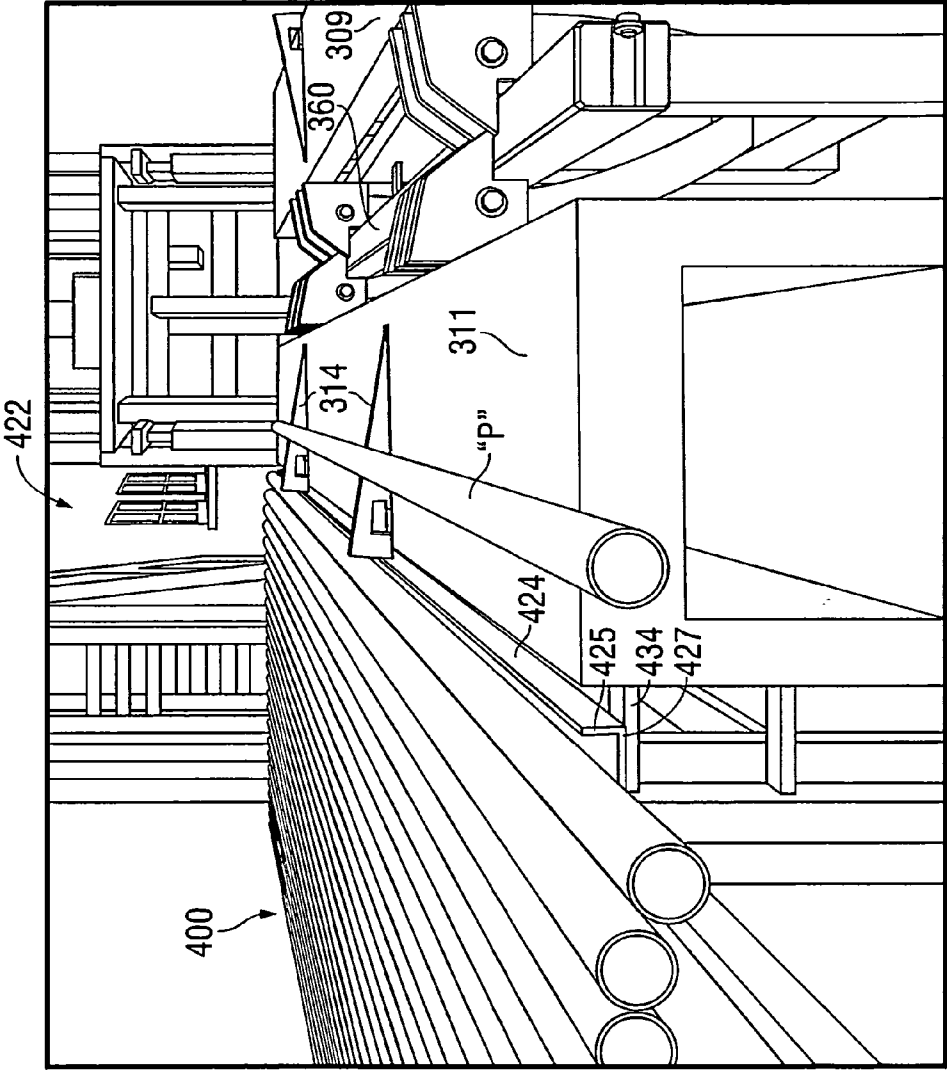
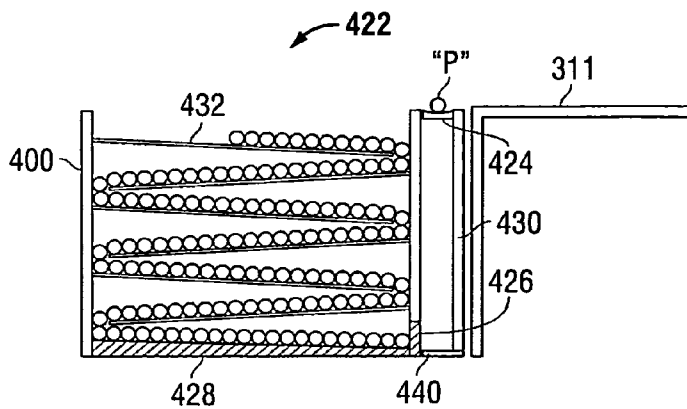
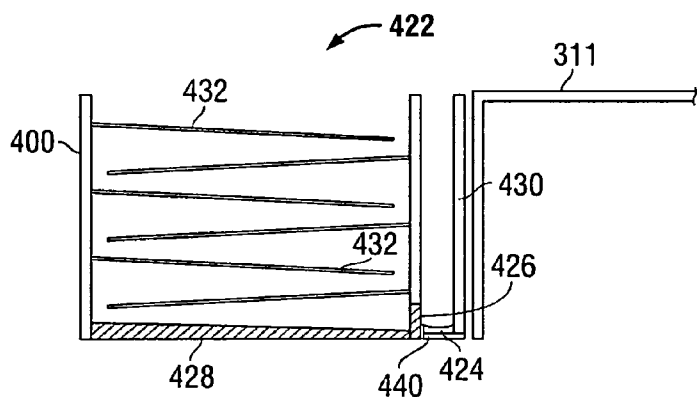

FIG. 23B



**FIG. 23C**



**FIG. 23D**

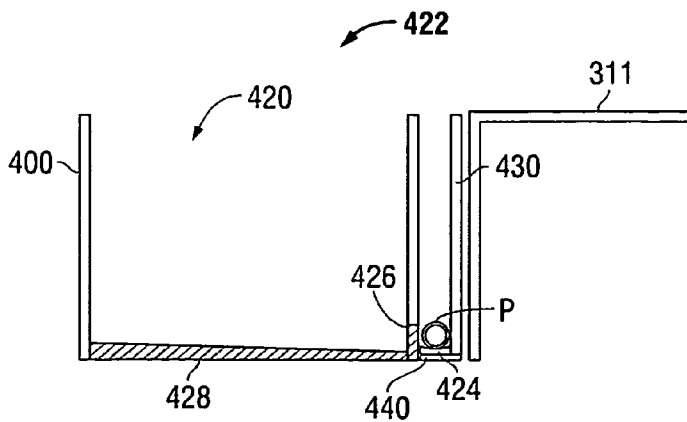

**FIG. 23E**

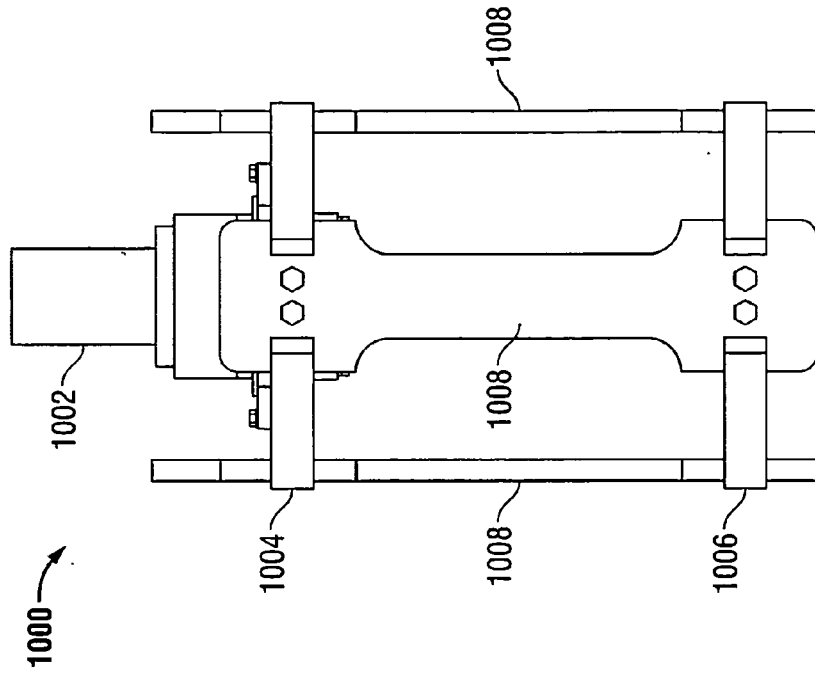

FIG. 24B

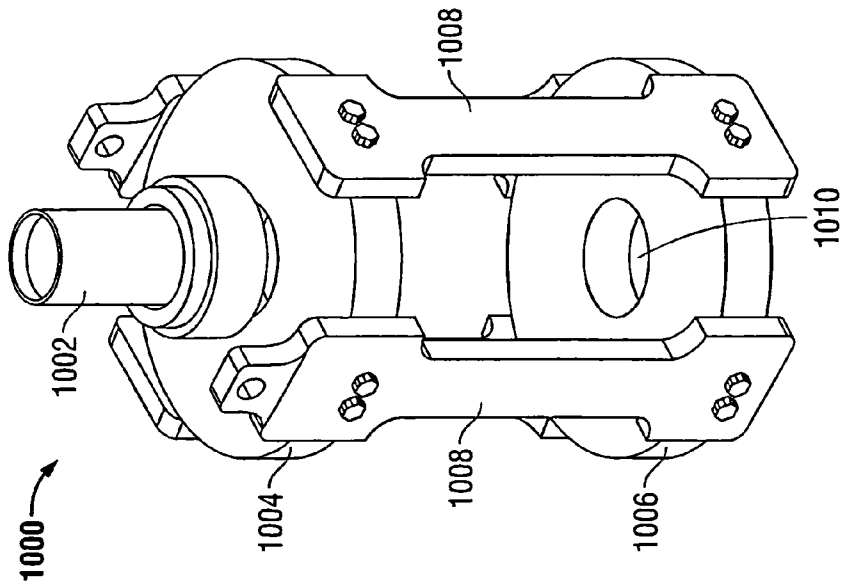

FIG. 24A

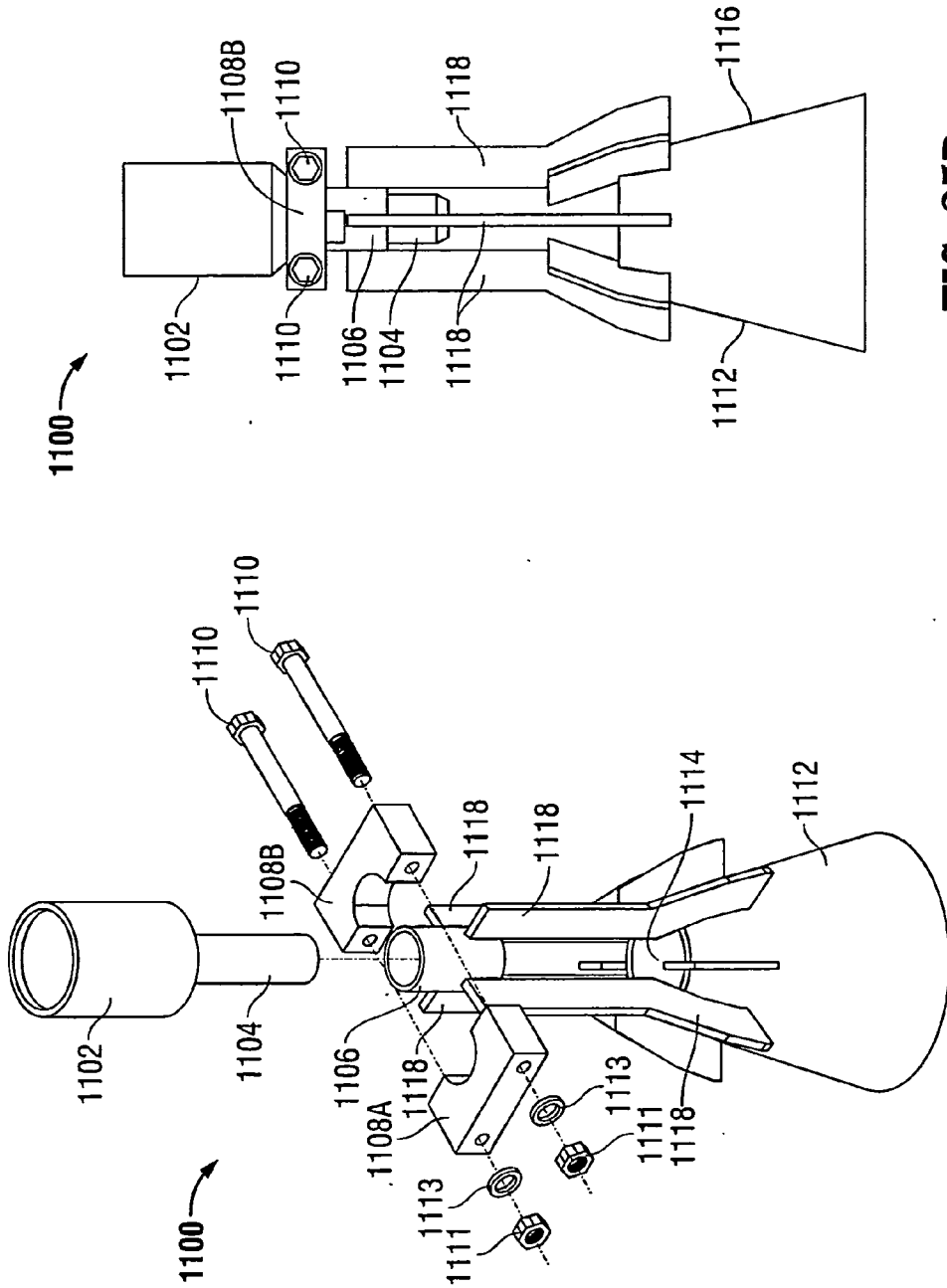
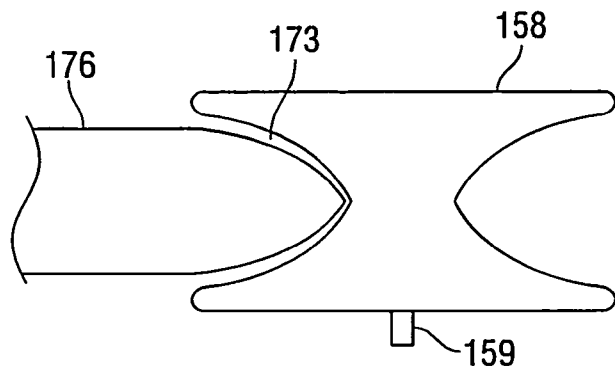
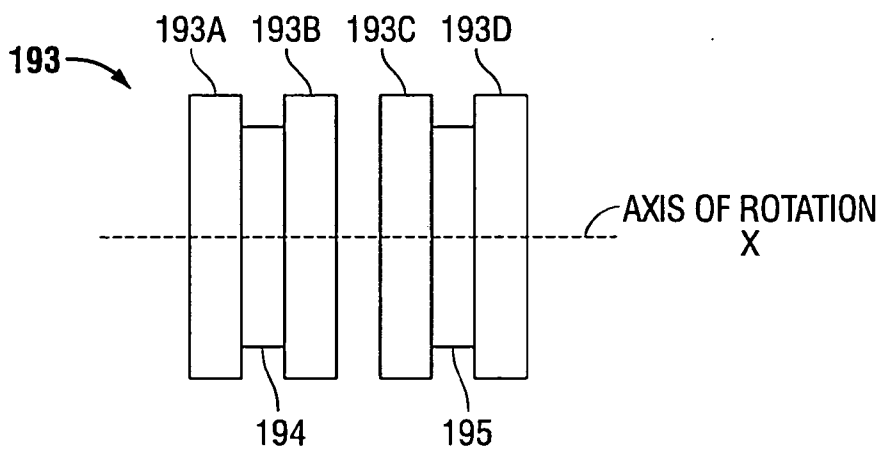

FIG. 25B

FIG. 25A



**FIG. 26**



**FIG. 27A**

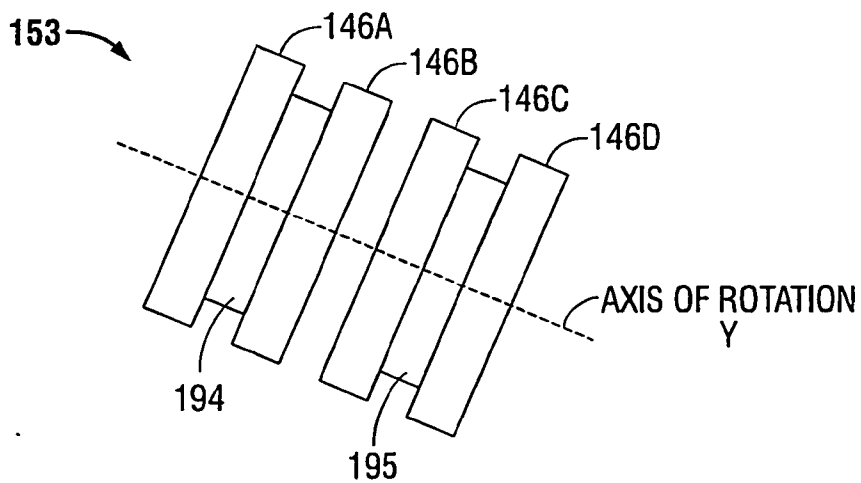

**FIG. 27B**

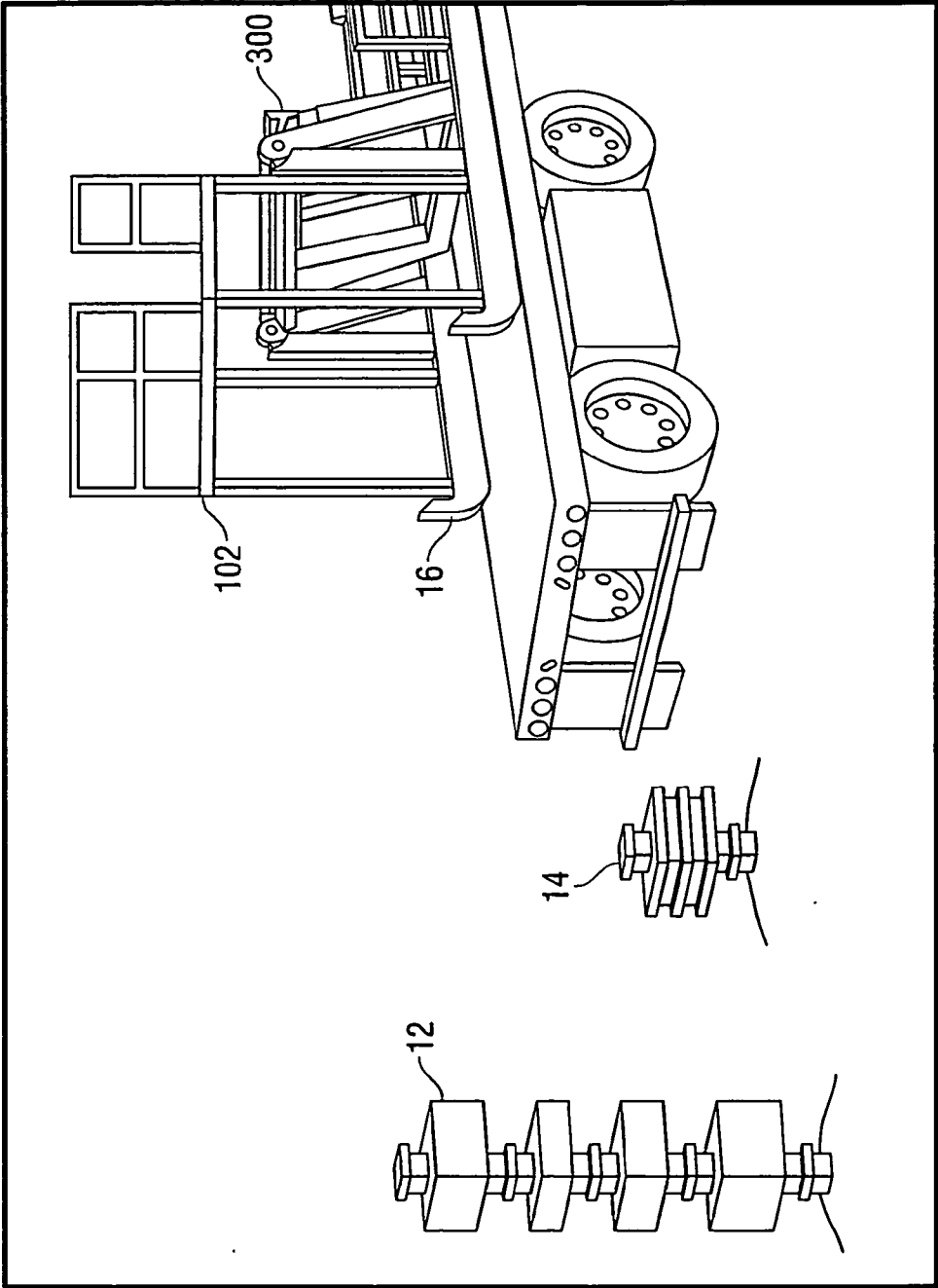

FIG. 28A



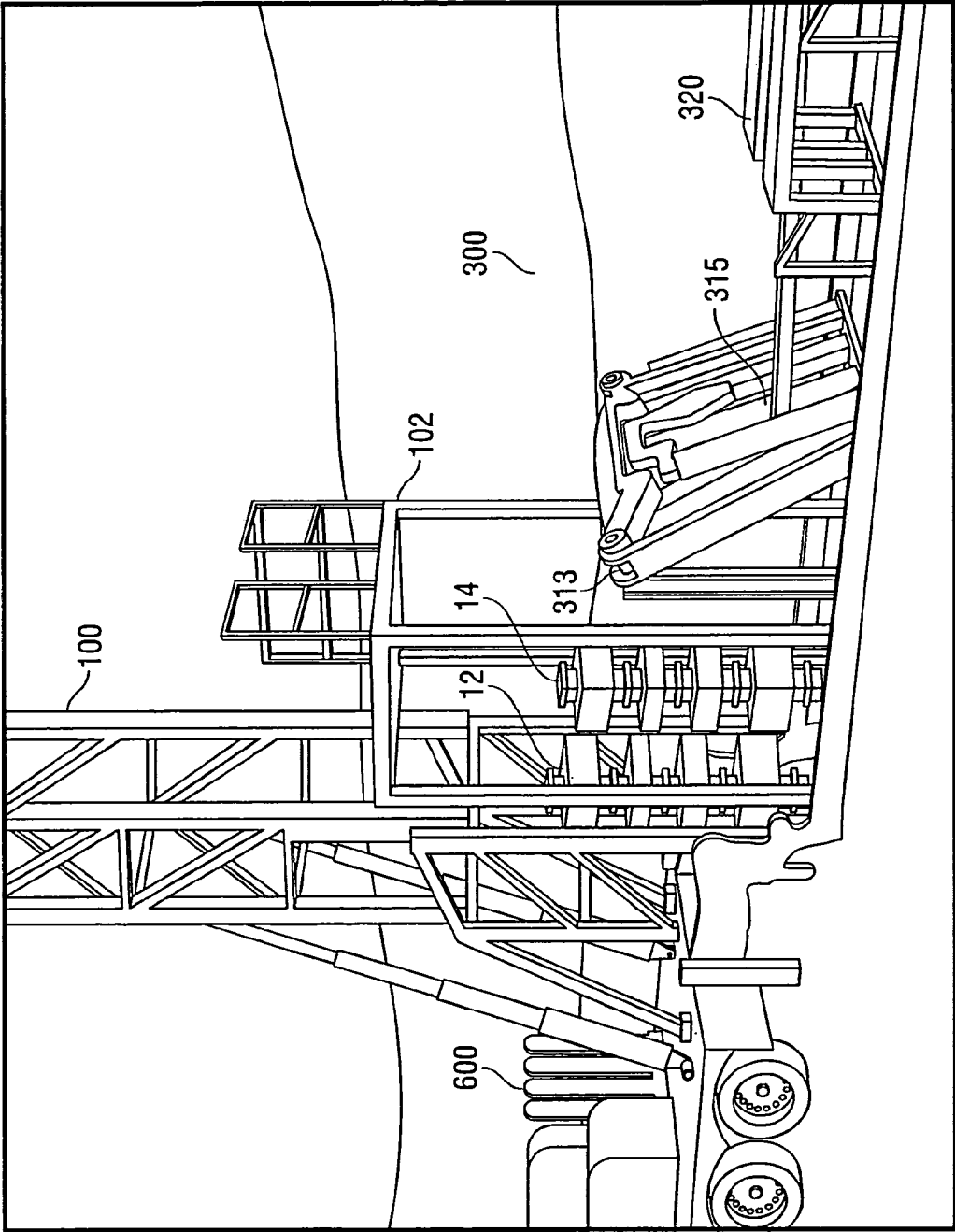

FIG. 28B

**LONG LATERAL COMPLETION SYSTEM  
PIPE TONG AND METHOD OF USING THE  
SAME**

**TECHNICAL FIELD**

**[0001]** One possible embodiment of the present disclosure relates, generally, to the field of producing hydrocarbons from subsurface formations. Further, one possible embodiment of the present disclosure relates, generally, to the field of making a well ready for production or injection. More particularly, one possible embodiment of the present disclosure relates to completion systems and methods adapted for use in wells having long lateral boreholes.

**BACKGROUND**

**[0002]** In petroleum production, completion is the process of making a well ready for production or injection. This principally involves preparing the bottom of the hole to the required specifications, running the production tubing and associated down hole tools, as well as perforating and/or stimulating the well as required. Sometimes, the process of running and cementing the casing is also included.

**[0003]** Lower completion refers to the portion of the well across the production or injection zone, beneath the production tubing. A well designer has many tools and options available to design the lower completion according to the conditions of the reservoir. Typically, the lower completion is set across the production zone using a liner hanger system, which anchors the lower completion equipment to the production casing string.

**[0004]** Upper completion refers to all components positioned above the bottom of the production tubing. Proper design of this "completion string" is essential to ensure the well can flow properly given the reservoir conditions and to permit any operations deemed necessary for enhancing production and safety.

**[0005]** In cased hole completions, which are performed in the majority of wells, once the completion string is in place, the final stage includes making a flow path or connection between the wellbore and the formation. The flow path or connection is created by running perforation guns into the casing or liner and actuating the perforation guns to create holes through the casing or liner to access the formation. Modern perforations can be made using shaped explosive charges.

**[0006]** Sometimes, further stimulation is necessary to achieve viable productivity after a well is fully completed. There are a number of stimulation techniques which can be employed at such a time.

**[0007]** Fracturing is a common stimulation technique that includes creating and extending fractures from the perforation tunnels deeper into the formation, thereby increasing the surface area available for formation fluids to flow into the well and avoiding damage near the wellbore. This may be done by injecting fluids at high pressure (hydraulic fracturing), injecting fluids laced with round granular material (proppant fracturing), or using explosives to generate a high pressure and high speed gas flow (TNT or PETN, and propellant stimulation).

**[0008]** Hydraulic fracturing, often called fracking, fracing or hydrofracking, is the process of initiating and subsequently propagating a fracture in a rock layer, by means of a pressurized fluid, in order to release petroleum, natural gas, coal

steam gas or other substances for extraction. The fracturing, known colloquially as a frack job or frac job, is performed from a wellbore drilled into reservoir rock formations. The energy from the injection of a highly pressurized fluid, such as water, creates new channels in the rock that can increase the extraction rates and recovery of fossil fuels.

**[0009]** The technique of fracturing is used to increase or restore the rate at which fluids, such as oil or water, or natural gas can be produced from subterranean natural reservoirs, including unconventional reservoirs such as shale rock or coal beds. Fracturing enables the production of natural gas and oil from rock formations deep below the earth's surface, generally 5,000-20,000 feet or 1,500-6,100 meters. At such depths, there may not be sufficient porosity and permeability to allow natural gas and oil to flow from the rock into the wellbore at economic rates. Thus, creating conductive fractures in the rock is essential to extract gas from shale reservoirs due to the extremely low natural permeability of shale. Fractures provide a conductive path connecting a larger area of the reservoir to the well, thereby increasing the area from which natural gas and liquids can be recovered from the targeted formation.

**[0010]** Pumping the fracturing fluid into the wellbore, at a rate sufficient to increase pressure downhole, until the pressure exceeds the fracture gradient of the rock and forms a fracture. As the rock cracks, the fracture fluid continues to flow farther into the rock, extending the crack farther. To prevent the fracture(s) from closing after the injection process has stopped, a solid proppant, such as a sieved round sand, can be added to the fluid. The propped fracture remains sufficiently permeable to allow the flow of formation fluids to the well.

**[0011]** The location of fracturing along the length of the borehole can be controlled by inserting composite plugs, also known as bridge plugs, above and below the region to be fractured. This allows a borehole to be progressively fractured along the length of the bore while preventing leakage of fluid through previously fractured regions. Fluid and proppant are introduced to the working region through piping in the upper plug. This method is commonly referred to as "plug and perf."

**[0012]** Typically, hydraulic fracturing is performed in cased wellbores, and the zones to be fractured are accessed by perforating the casing at those locations.

**[0013]** While hydraulic fracturing can be performed in vertical wells, today it is more often performed in horizontal wells. Horizontal drilling involves wellbores where the terminal borehole is completed as a "lateral" that extends parallel with the rock layer containing the substance to be extracted. For example, laterals extend 1,500 to 5,000 feet in the Barnett Shale basin. In contrast, a vertical well only accesses the thickness of the rock layer, typically 50-300 feet. Horizontal drilling also reduces surface disruptions, as fewer wells are required. Drilling a wellbore produces rock chips and fine rock particles that may enter cracks and pore space at the wellbore wall, reducing the porosity and/or permeability at and near the wellbore. The production of rock chips, fine rock particles and the like reduces flow into the borehole from the surrounding rock formation, and partially seals off the borehole from the surrounding rock. Hydraulic fracturing can be used to restore porosity and/or permeability.

**[0014]** Conventional lateral wells are completed by inserting coiled tubing or a similar, generally flexible conduit therein, until the flexible nature of the tubing prevents further

insertion. While coil tubing does not require making up and/or breaking out each pipe joint, coiled tubing cannot be rotated, which increases the likelihood of sticking and significantly reduces the ability to extend the pipe laterally. Once a certain depth is reached in a highly angled and/or horizontal well, the pipe essentially acts like soft spaghetti and can no longer be pushed into the hole. Coiled tubing is also more limited in terms of pipe wall thickness to provide flexibility thereby limiting the weight of the string.

**[0015]** Conventional completion rigs include a mast, which extends upward and slightly outward typically at approximately a 3 degree angle from a carrier or similar base structure. The angled mast provides that cables and/or other features that support a top drive and/or other equipment can hang downward from the mast, directly over a wellbore, without contacting the mast. For example, most top drives and/or power swivels require a "torque arm" to be attached thereto, the torque arm including a cable that is secured to the ground or another fixed structure to counteract excess torque and/or rotation applied to the top drive/power swivel. Additionally, a blowout preventer stack, having sufficient components and a height that complies with required regulations, must be positioned directly above the wellbore. A mast having a slight angle accommodates for these and other features common to completion rigs. As a result, a rig must often be positioned at least four feet, or more, away from the wellbore depending on the height of the mast. A need exists for systems and methods having a reduced footprint, especially in lucrative regions where closer spacing of wells can significantly affect production and economic gain, and in marginal regions, where closer spacing of wells would be necessary to enable economically viable production.

**[0016]** Prior to common use of coiled tubing, completion operations involved often involved the use of workover/production rigs for insertion of successive joints of pipe, which must be threaded together and torqued, often by hand, creating a significant potential for injury or death of laborers involved in the completion operation, and requiring significant time to engage (e.g., "make up") each pipe joint. Drilling rigs could also be utilized to run production tubing but are more expensive although the individual joints of pipes result in the same types of problems.

**[0017]** A significant problem with prior art production/workover rigs or drilling rigs as opposed to coiled tubing units is that individual production tubing pipe connections are often considerably more difficult to make up and/or break out than the drilling pipe connections. Drilling pipe connections are enlarged and are designed for quick make up and break out many times with very little concern about exact alignment of the connectors. Drill pipe is designed to be frequently and quickly made up and broken out without being damaged even if the alignment is not particularly precise. On the other hand, production tubing is normally intended for long term use in the well and requires much more accurate alignment of the connectors to avoid damaging the threads. Production tubing does not typically utilize the expensive enlarged connectors like drill pipe and, in some completions, enlarged connectors simply are not feasible due to clearance problems within the wellbore. Thus, especially for production tubing, prior art workover/production rigs are much slower for inserting and/or removing production tubing pipe into or out of the well than coiled tubing units and are more likely to result in operator injuries and errors during pipe connection make up and break out than coiled tubing. There are also problems with

human error in aligning the individual production tubing connectors whereby cross-threading could result in a damaged or leaking connection.

**[0018]** Prior art insertion techniques of completion tubing into a lateral well therefore suffers from significant limitations including but not limited to: 1) the longer time required to run tubing into a well; 2) operator safety; and 3) the maximum horizontal distance across which the tubing can be inserted is limited by the nature of the tubing used and/or the force able to be applied from the surface. Generally, once the frictional forces between the lateral portion of the well and the length of tubing therein exceed the downward force applied by the weight of the tubing in the vertical portion of the well, further insertion becomes extremely difficult, if not impossible, thus limiting the maximum length of a lateral.

**[0019]** Due to the significant day rates and rental costs when performing oilfield operations, a need exists for systems and methods capable of faster, yet safer insertion of pipe and/or tubing into a well. Additionally, due to the costs associated with the drilling, completion, and production of a well, a need exists for systems and methods capable of extending the maximum length of a lateral, thereby increasing the productivity of the well.

**[0020]** Hydraulic fracturing is commonly applied to wells drilled in low permeability reservoir rock. An estimated 90 percent of the natural gas wells in the United States use hydraulic fracturing to produce gas at economic rates.

**[0021]** The fluid injected into the rock is typically a slurry of water, proppants, and chemical additives. Additionally, gels, foams, and/or compressed gases, including nitrogen, carbon dioxide and air can be injected. Various types of proppant include silica sand, resin-coated sand, and man-made ceramics. The type of proppant used may vary depending on the type of permeability or grain strength needed. Sand containing naturally radioactive minerals is sometimes used so that the fracture trace along the wellbore can be measured. Chemical additives can be applied to tailor the injected material to the specific geological situation, protect the well, and improve its operation, though the injected fluid is approximately 99 percent water and 1 percent proppant, this composition varying slightly based on the type of well. The composition of injected fluid can be changed during the operation of a well over time. Typically, acid is initially used to increase permeability, then proppants are used with a gradual increase in size and/or density, and finally, the well is flushed with water under pressure. At least a portion of the injected fluid can be recovered and stored in pits or containers; the fluid can be toxic due to the chemical additives and material washed out from the ground. The recovered fluid is sometimes processed so that at least a portion thereof can be reused in fracking operations, released into the environment after treatment, and/or left in the geologic formation.

**[0022]** Advances in completion technology have led to the emergence of open hole multi-stage fracturing systems. These systems effectively place fractures in specific places in the wellbore, thus increasing the cumulative production in a shorter time frame.

**[0023]** Those of skill in the art will appreciate the present system which addresses the above and other problems.

#### BRIEF DESCRIPTION OF THE DRAWINGS

**[0024]** The accompanying drawings, which are incorporated in and constitute a part of this specification, illustrate an implementation of apparatus consistent with one possible

embodiment of the present disclosure and, together with the detailed description, serve to explain advantages and principles consistent with the disclosure. In the drawings,

[0025] FIG. 1 illustrates an embodiment of a long lateral completion system usable within the scope of one possible embodiment of the present disclosure.

[0026] FIG. 2 is a perspective view of the mast assembly, pipe arm, pipe tubs, and the carrier of the long lateral completion system of FIG. 1 in accord with one possible embodiment of the completion system of the present disclosure.

[0027] FIG. 3 is a plan view of the carrier, mast assembly, pipe arm, and pipe tub of the long lateral completion system of FIG. 1 in accord with one possible embodiment of the completion system of the present disclosure.

[0028] FIG. 4 is an illustration of the carrier of the long lateral completion system of FIG. 1 in accord with one possible embodiment of the completion system of the present disclosure.

[0029] FIG. 4A-A is a cross sectional view of the carrier of FIG. 4 taken along the section line A-A in accord with one possible embodiment of the completion system of the present disclosure.

[0030] FIG. 4B-B is a cross sectional view of the carrier of FIG. 4 taken along the section line B-B in accord with one possible embodiment of the completion system of the present disclosure.

[0031] FIG. 5 is an elevation view of the carrier, the mast assembly, the pipe arm and the pipe tubs of the long lateral completion system of FIG. 1 in accord with one possible embodiment of the completion system of the present disclosure.

[0032] FIG. 5A is an enlarged or detailed view of the section identified in FIG. 5 as "A" of the rear portion of the carrier engaged with a skid of the depicted long lateral completion system in accord with one possible embodiment of the completion system of the present disclosure.

[0033] FIG. 6 illustrates an elevation view of the completion system of FIG. 1 with the mast assembly extended in a perpendicular relationship with the carrier and the pipe tubs in accord with one possible embodiment of the completion system of the present disclosure.

[0034] FIG. 6A is an enlarged or detailed view of the portion of FIG. 6 indicated as section "A" illustrating the relationship of the mast assembly, the deck and the base beam in accord with one possible embodiment of the completion system of the present disclosure.

[0035] FIG. 7 is an elevation view of the carrier, the mast assembly, the pipe arm, and the pipe tub of FIG. 1, with the mast assembly shown in a perpendicular relationship with the carrier, and the pipe arm engaged with the mast in accord with one possible embodiment of the completion system of the present disclosure.

[0036] FIG. 7A-A is a cross sectional view of FIG. 7 taken along the section line A-A showing the mast assembly and top drive of the depicted long lateral completion system in accord with one possible embodiment of the completion system of the present disclosure.

[0037] FIG. 7B is a perspective view of the portion of the mast assembly and pipe arm illustrated in FIG. 7A-A in accord with one possible embodiment of the completion system of the present disclosure.

[0038] FIG. 8 is an elevation view of the completion system of FIG. 1 illustrating the mast assembly in a perpendicular relationship with the carrier, including the use of a hydraulic

pipe tong in accord with one possible embodiment of the completion system of the present disclosure.

[0039] FIG. 8A-A is a cross sectional view of the system of FIG. 8 taken along the section line A-A, showing the pipe tong with respect to the mast assembly in accord with one possible embodiment of the completion system of the present disclosure.

[0040] FIG. 8B-B is a cross sectional view of the system of FIG. 8 taken along the section line B-B, showing the mast assembly and top drive in accord with one possible embodiment of the completion system of the present disclosure.

[0041] FIG. 8C is a perspective view of the portion of the system shown in FIG. 8B in accord with one possible embodiment of the completion system of the present disclosure.

[0042] FIG. 9 is an illustration of the long lateral completion system of FIG. 1, depicting the relationship between the carrier, the mast assembly, the pipe arm, the pipe tubs and a blowout preventer in accord with one possible embodiment of the completion system of the present disclosure.

[0043] FIG. 9A-A is a cross sectional view of the system of FIG. 9 taken along the section line A-A, illustrating the upper portion of the mast assembly in accord with one possible embodiment of the completion system of the present disclosure.

[0044] FIG. 9B is a perspective view of the upper portion of the mast assembly as illustrated in FIG. 9A-A, showing the top drive and the pipe clam in accord with one possible embodiment of the completion system of the present disclosure.

[0045] FIG. 9C-C is a cross sectional view of the system of FIG. 9 taken along the section line C-C, illustrating the relationship of the blowout preventer to the completion system in accord with one possible embodiment of the completion system of the present disclosure.

[0046] FIG. 10A is an illustration of an embodiment of a pipe tong fixture usable in accord with one possible embodiment of the completion system of the present disclosure.

[0047] FIG. 10B is a perspective view of the pipe tong fixture of FIG. 10A.

[0048] FIG. 11A, FIG. 11B, FIG. 11C, and FIG. 11D illustrate an embodiment of a compact snubbing unit usable in accord with one possible embodiment of the completion system of the present disclosure.

[0049] FIG. 12A is a schematic view of an embodiment of a control cabin usable in accord with one possible embodiment of the completion system of the present disclosure.

[0050] FIG. 12B is an elevation view of the control cabin of FIG. 12A in accord with one possible embodiment of the completion system of the present disclosure.

[0051] FIG. 12C is a first end view (e.g., a left side view) of the control cabin of FIG. 12A in accord with one possible embodiment of the completion system of the present disclosure.

[0052] FIG. 12D is an opposing end view (e.g., a right side view) of the control cabin of FIG. 12A in accord with one possible embodiment of the completion system of the present disclosure.

[0053] FIG. 13 is an illustration of an embodiment of a carrier adapted for use in accord with one possible embodiment of the completion system of the present disclosure.

[0054] FIG. 14 is an illustration of an embodiment of a pipe arm usable in accord with one possible embodiment of the completion system of the present disclosure.

[0055] FIG. 14A depicts a detail view of an engagement between the pipe arm of FIG. 14 and an associated skid in accord with one possible embodiment of the completion system of the present disclosure.

[0056] FIG. 15A is an elevation view of the pipe arm of FIG. 14 in accord with one possible embodiment of the completion system of the present disclosure.

[0057] FIG. 15B is an exploded view of a portion of the pipe arm of FIG. 15A, indicated as section "B" in accord with one possible embodiment of the completion system of the present disclosure.

[0058] FIG. 15C is an enlarged or detailed view of a portion of the pipe arm of FIG. 15A, indicated as section "C" in accord with one possible embodiment of the completion system of the present disclosure.

[0059] FIG. 15D is an enlarged or detailed view of a portion of the pipe arm of FIG. 15A, indicated as section "D" in accord with one possible embodiment of the completion system of the present disclosure.

[0060] FIG. 15E is a plan view of the pipe arm of FIG. 14 in accord with one possible embodiment of the completion system of the present disclosure.

[0061] FIGS. 15F and 15G are end views of the pipe arm of FIG. 14 in accord with one possible embodiment of the completion system of the present disclosure.

[0062] FIG. 16A is an elevation view of the pipe arm of FIG. 14 in accord with one possible embodiment of the completion system of the present disclosure.

[0063] FIG. 16B is a plan view of the pipe arm of FIG. 14 in accord with one possible embodiment of the completion system of the present disclosure.

[0064] FIG. 16C is an enlarged or detailed view of a portion of the pipe arm of FIG. 16A, indicated as section "C" in accord with one possible embodiment of the completion system of the present disclosure.

[0065] FIG. 16D is an end view of the pipe arm of FIG. 14 in accord with one possible embodiment of the completion system of the present disclosure.

[0066] FIG. 17 is a perspective view of an embodiment of a kickout arm usable in accord with one possible embodiment of the completion system of the present disclosure.

[0067] FIG. 17A is an enlarged or detailed view of an embodiment of a clamp of the kickout arm of FIG. 17 in accord with one possible embodiment of the completion system of the present disclosure.

[0068] FIG. 18A is an elevation view of the kickout arm of FIG. 17 in accord with one possible embodiment of the completion system of the present disclosure.

[0069] FIG. 18B is a bottom view of the kickout arm of FIG. 17 in accord with one possible embodiment of the completion system of the present disclosure.

[0070] FIG. 18C is a top view of the kickout arm of FIG. 17 in accord with one possible embodiment of the completion system of the present disclosure.

[0071] FIG. 18B-B is a sectional view of the end taken along the section line B-B in FIG. 18B in accord with one possible embodiment of the completion system of the present disclosure.

[0072] FIG. 18C-C is a cross sectional view of the kickout arm of FIG. 18C taken along the section line C-C in accord with one possible embodiment of the completion system of the present disclosure.

[0073] FIG. 19A is an elevation view of an embodiment of a top drive fixture usable with the mast assembly of embodi-

ments of the completion system in accord with one possible embodiment of the completion system of the present disclosure.

[0074] FIG. 19B is a side view of the top drive fixture illustrated in FIG. 19A in accord with one possible embodiment of the completion system of the present invention.

[0075] FIG. 19C-C is a cross sectional view of the top drive fixture of FIG. 19B taken along the section line C-C in accord with one possible embodiment of the completion system of the present disclosure.

[0076] FIG. 19D is an enlarged or detailed view of a portion of the top drive fixture of FIG. 19B indicated as section "D" in accord with one possible embodiment of the completion system of the present disclosure.

[0077] FIG. 19E-E is a cross sectional view of the top drive fixture of FIG. 19A taken along the section line E-E in accord with one possible embodiment of the completion system of the present disclosure.

[0078] FIG. 20A is an illustration of a top drive within the top drive fixture of FIG. 19A in accord with one possible embodiment of the completion system of the present disclosure.

[0079] FIG. 20A-A is a cross sectional view of the top drive and fixture of FIG. 20A taken along section line A-A in accord with one possible embodiment of the completion system of the present disclosure.

[0080] FIG. 20B is a top view of the top drive and fixture of FIG. 20A in accord with one possible embodiment of the completion system of the present disclosure.

[0081] FIG. 21A is a perspective view of a pivotal pipe arm having a pipe thereon with pipe clamps retracted to allow a pipe to be received into receptacles of the pipe arm in accord with one possible embodiment of the completion system of the present disclosure.

[0082] FIG. 21B is a perspective view of a pivotal pipe arm having a pipe thereon with pipe clamps engaged with the pipe whereby the pipe arm can be moved to an upright position in accord with one possible embodiment of the completion system of the present disclosure.

[0083] FIG. 22A is an end perspective view of a walkway with pipe moving elements whereby the pipe moving elements are positioned to urge pipe into a pipe arm in accord with one possible embodiment of the completion system of the present disclosure.

[0084] FIG. 22B is an end perspective view of a walkway with pipe moving elements whereby a pipe has been urged into a pipe arm by pipe moving elements in accord with one possible embodiment of the completion system of the present disclosure.

[0085] FIG. 23A is an end perspective view of a pipe feeding mechanism whereby a pipe is transferred from a pipe tub into a pipe arm in accord with one possible embodiment of the present disclosure.

[0086] FIG. 23B is another end perspective view of a pipe feeding mechanism whereby a pipe is transferred from a pipe tub into a pipe arm in accord with one possible embodiment of the present disclosure.

[0087] FIG. 23C is a cross sectional view of a pipe feeding mechanism whereby a pipe is transferred from a pipe tub into a pipe arm in accord with one possible embodiment of the present disclosure.

[0088] FIG. 23D is a cross sectional view of a pipe feeding mechanism with the pipes removed in accord with one possible embodiment of the present disclosure.

[0089] FIG. 23E is a cross sectional view of a pipe feeding mechanism whereby a pipe is transferred from a pipe tub into a pipe arm in accord with one possible embodiment of the present disclosure.

[0090] FIG. 24A is a perspective view of an embodiment of a gripping apparatus engageable with a top drive of one possible embodiment of the present disclosure.

[0091] FIG. 24B depicts a diagrammatic side view of the gripping apparatus of FIG. 24A.

[0092] FIG. 26 is a top view of a roller engaged with a guide rail in accord with one possible embodiment of the present disclosure.

[0093] FIG. 27A is a top view of a crown block sheave assembly showing an axis of rotation in accord with one possible embodiment of the present disclosure.

[0094] FIG. 27B is a top view of a traveling sheave block showing an axis of rotation in accord with one possible embodiment of the present disclosure.

[0095] FIG. 28A is a perspective view of a system for conducting a long lateral well completion system of multiple wellheads in close proximity in accord with one possible embodiment of the present invention.

[0096] FIG. 28B is another perspective view of a system for conducting a long lateral well completion system of multiple wellheads in close proximity in accord with one possible embodiment of the present invention.

[0097] The above general description and the following detailed description are merely illustrative of the generic invention, and additional modes, advantages, and particulars of this invention will be readily suggested to those skilled in the art without departing from the spirit and scope of the invention.

#### DESCRIPTION OF EMBODIMENTS

[0098] FIG. 1 illustrates an embodiment of a long lateral completion system 10 usable in accord with one possible embodiment of the completion system of the present disclosure. In this embodiment, the completion system 10 is shown having a mast assembly 100, which extends in a generally vertical direction (i.e., perpendicular to the rig carrier 600 and/or the earth's surface), a pipe handling mechanism 200, a catwalk-pipe arm assembly 300, two pipe tubs 400, a pump pit combination skid 500, a rig carrier 600 usable to transport the mast assembly 100 and various hydraulic and/or motorized pumps and power sources for raising and lowering the mast assembly 100 and operating other rig components, and a control van 700, used to control operation of one or more of the components of long lateral completion system 10. Other embodiments may comprise the desired completion system 10 components otherwise arranged on skids as desired. For example, in another embodiment, separate pump and pit skids might be utilized. In another embodiment, catwalk pipe tubes with tube handling elements might be combined on one skid with pipe arm assembly 300 provided separately. It will be appreciated that many different embodiments may be utilized. Accordingly, FIG. 1 shows one possible arrangement of various components of the completion system 10 that can be implemented around a well (e.g., an oil, natural gas, or water well). Due to the construction, system 10 can work with wells that are in close proximity to each other, e.g. within ten feet of each other. For example, mast assembly 100 may be located above a first well, as discussed hereinafter, and rig floor 102 (if used) may be elevated above a second capped wellhead (not shown) within ten feet of the first well. Sensors, such as

laser sights, guides mounted to the rear of rig carrier 600, and the like may be utilized, e.g., mounted to and/or guided to the well head, to locate and orient the axis of drilling rig mast 100 precisely with respect to the wellbore, which in one embodiment may be utilized to align a top drive mounted on guide rails with the wellbore, as discussed hereinafter.

[0099] Control van 700 and automated features of system 10 can allow a single operator in the van to view and operate the truck mounted production rig by himself, including raising the derrick, picking up pipe, torquing to the desired torque levels for tubing, going in the hole, coming out of the hole, performing workover functions, drilling out plugs, and/or other steps completing the well, which in the prior art required a rig crew, some problems of which were discussed above. In other embodiments, the control van 700 and/or other features can be configured for use and operation by multiple operators. Control van 700 may comprise a window arrangement with windows at the top, front, sides and rear (See e.g., FIG. 12B), so that once positioned in a desired position on the well site, all operations to the top of mast 100 are readily visible.

[0100] For example, embodiments of the system 10 can be positioned for real time operation, e.g., by a single individual operating the control van 700 and/or a similar control system, and further embodiments can be used to perform various functions automatically, e.g., after calibrating the system 10 for certain movements of the pipe arm assembly 300, the top drive or a similar type of drive unit along the mast assembly 100, etc. After providing the system 10 in association with a wellbore, e.g., by erecting the mast assembly 100 vertically thereabove, a tubular segment can be transferred from one or more pipe tubs and/or similar vessels to the pipe arm assembly 300, and the control van 700 and/or a similar system can be used to engage the tubular segment with a pipe moving arm thereof. For example, as described hereinafter, hydraulic members of the pipe tubs and/or similar vessels can be used to urge a tubular member over a stop into a position for engagement with a pipe moving arm, while hydraulic grippers thereof can be actuated to grip the tubular member. The control system can then be used to raise the pipe moving arm and align the tubular segment with the mast assembly, which can include extension of a kick-out arm from the pipe moving arm, further described below. Alignment of the tubular segment with the mast assembly could further include engagement of the tubular segment by grippers (e.g., hydraulic clamps and/or jaws) positioned along the mast. The control system is further usable to move the top drive along the mast assembly to engage the tubular segment (e.g., through rotation thereof), to disengage the pipe moving arm from the tubular, and to further move the top drive to engage the tubular segment with a tubular string associated with the wellbore. While the system is depicted having a pipe moving arm used to raise gripped segments of pipe into association and/or alignment with the mast, in other embodiments, a catwalk-type pipe handling system in which the front end of each pipe segment is pulled and/or lifted into a desired position, while the remainder of the pipe segment travels along a catwalk, can be used.

[0101] In an embodiment, any of the aforementioned operations can be automated. For example, the control system can be used to calibrate movement of the drive unit along the mast assembly, e.g., by determining a suitable vertical distance to travel to engage a top drive with a tubular segment positioned by the pipe moving arm, and a suitable vertical

distance to travel to engage a tubular segment engaged by the top drive with a tubular string below, such that movement of a top drive between positions for engagement with tubular members and engagement of tubular members with a tubular string can be performed automatically thereafter. The control system can also be used to calibrate movement of the pipe moving arm between raised and lowered positions, depending on the position of the mast assembly 100 relative to the pipe arm assembly 300 after positioning the system 10 relative to the wellbore. Then, future movements of the pipe moving arm, and the kick-out arm, if used, can be automated. In a similar manner, grippers on the mast assembly 100, if used, annular blowout preventers and/or ram/snubbing assemblies, and other components of the system 10 can be operated using the control system, and in an embodiment, in an automated fashion. After assembly of a completion string, further operations, such as fracturing, production, and/or other operations that include injection of substances into or removal of substances from the wellbore can be controlled using the control system, and in an embodiment, can be automated. In embodiments where a catwalk-type pipe handling system is used, operations of the catwalk-type pipe handling system can also be highly automated, including engagement of the front end of a pipe segment, lifting and/or otherwise moving the front end of the pipe segment, and the like.

[0102] FIG. 2 is a perspective view of the mast assembly 100, catwalk-pipe arm assembly 300, pipe tubs 400, and the carrier 600 of the long lateral completion system 10 in accord with one possible embodiment of the completion system of the present invention. The carrier 600 has the mast assembly 100 extending from the rear portion of the carrier 600. In one embodiment, the mast assembly 100 is essentially perpendicular to the carrier 600. In another embodiment, mast assembly 100 is aligned either coaxially, within less than three inches, or two inches, or one inch to an axis of the bore through the wellhead, BOPs, or the like when the top drive is positioned at a lower portion of the mast and/or is parallel to the axis of the borehole adjacent the surface of the well and/or the bore of the wellhead pressure equipment within less than five degrees, or less than three degrees, or less than one degree in another embodiment. For example, in one embodiment, mast rails 104, which guide top drive 150, may be aligned to be essentially parallel to the axis of the bore, within less than five degrees in one embodiment, or less than three degrees, or less than one degree in another embodiment, whereby top drive 150 moves coaxially or concentric to the well bore within a desired tolerance. As used herein a well completion system may be essentially synonymous with a workover system or drilling system or rig or drilling rig or the like. The system of the present invention may be utilized for completions, workovers, drilling, general operations, and the like and the term workover rig, completing rig, drilling rig, completion system, intervention system, operating system, and the like are used herein substantially interchangeably for the herein described system. Pipe as used herein may refer interchangeably to a pipe string, a single pipe, a single pipe that is connected to or removed from a pipe string, a stand of pipe for connection or removal from a pipe string, or a pipe utilized to build a pipe string, tubular, tubulars, tubular string, oil country tubulars, or the like.

[0103] The carrier 600 is illustrated with a power plant 650 and a winch or drawworks assembly 620. Winch or drawworks 620 can be utilized for lifting and lowering the top

drive 150 in mast 100 utilizing pulley arrangements in crown 190 and blocks associated with top drive 150. The mast positioning hydraulic actuators 630 provide for lifting the mast assembly 100 into a desired essentially vertical position, with respect to the axis of the borehole at the surface of the well, within a desired accuracy alignment angle. In one embodiment, a laser sight may be mounted to the wellbore with a target positioned at an upper portion of the mast to provide the desired accuracy of alignment. In this embodiment, crown laser alignment target 192 is provided adjacent crown 190. The mast assembly 100 is affixed to the rear portion of the carrier 600. Also the mast assembly 100 is illustrated with a top drive 150 and a crown 190. The top drive allows rotation of the tubing, which results in significant improvement when inserting pipe into high angled and/or horizontal well portions. Further associated with the mast assembly 100 and the carrier 600 is a mast support base beam 120 for providing stability to the carrier 600 and the mast assembly 100, e.g., by increasing the surface area that contacts the ground.

[0104] In one possible embodiment, a catwalk-pipe arm assembly 300 may be located proximate to the mast assembly 100, which, in one possible embodiment, may be utilized to automatically insert and/or remove pipe from the wellbore. In one embodiment, the pipe is not stacked in the rig but instead is stored in one or more moveable pipe tubs 400. Catwalk-pipe arm assembly 300 may be configured so that components are provided in different skids, as discussed hereinbefore, and as discussed hereinafter to some extent. In this example, catwalk-pipe arm assembly 300 has associated on either side thereof a pipe tub 400. However, pipe tubes 400 may be used on only one side, two on one side, or any configuration may be utilized that fits with the well site. While more than two pipe tubes can be utilized, usually not more than four pipe tubes are utilized. However, pipe racks or other means to hold and/or feed pipe may be utilized. It can be appreciated that multiple pipe tubes 400 are provided for supplying multiple pipes to the catwalk-pipe arm assembly 300. Pipe tubs 400 may or may not comprise feed elements, which guide each pipe as needed to roll across catwalk 302 to pivotal pipe arm 320. Conceivably, means (not shown) may be provided which allow torquing two or more pipes from associated pipe tubes for simultaneously handling stands of pipes utilizing pivotal pipe arm 300 for faster insertion into the well bore. However, in the presently shown embodiment, only one pipe at a time is typically handled by pipe arm 300. When handling stands of pipe, then the correspondingly lengthened mast 100 may be carried in multiple carrier trucks 600.

[0105] The pipe tubs are preferably capable of holding multiple joints of pipe for delivery to the pipe arm. The pipe tubs are further preferably capable of continuously lifting and feeding a section of pipe to the pipe arm. The pipe tubs in some embodiments can be positioned in an orientation substantially parallel to the pipe arm, so that the sections of pipe are in a length-wise orientation parallel to the pipe arm. A pipe tub may further comprise a hydraulic lifting system for raising the floor or bottom shelf of the pipe tub in an upwards direction away from the ground and additionally may be used to tilt the pipe tub, so as to lift and roll one or more sections of pipe into a position to be received by the pipe arm. The pipe tubs could additionally include a series of pins along the edge of the pipe tub closest to the pipe arm, which feeds the sections of pipe to the pipe arm. However, preferably the series of pins are disposed on the pipe arm skid at a location proximate to the adjacent edge of the pipe tubs. These pins

serve the purpose of stopping or preventing a joint of pipe from rolling onto the pipe arm or pipe arm skid prematurely. Each pipe tub used in the pipe handling system can further incorporate one or more flipper arms, which is hydraulically actuated arms or plates to push or bump a section of pipe over the above mentioned pins when the pipe handling skid and pipe arm are in a position to receive the said section of pipe. Preferably, the pipe arm skid includes one or more flipper arms which pivotally rotate in an upward direction and which engage the joints of pipe to lift the joints of pipe over the pins retaining the joint(s) of pipe, whether the pins are disposed along the edge of the pipe arm skid or on the edge of the pipe tub. It can be appreciated that as an alternative to the pipe tubs **400** could be off the ground pipe ramps, saw horses, or tables. The selection of the apparatus (e.g. pipe tubs, ramps, saw horses, or tables) for delivery of pipe joints to the pipe arm depends on the physical layout of the surrounding area and if there are any obstructions or hazards that need to be avoided or overcome.

[0106] Various types of scanners such as laser scanners for bar codes, RFIDs, and the like may be utilized to monitor each pipe whereby the amount of usage, the length, torque history and other applied stresses, testing history of wall thickness, wear, and the like may be recorded, retrieved, and viewed. If desired, the pipe tub and/or catwalk may comprise sensors to automatically measure the length of each pipe. Thus, the operator in the van can automatically keep a pipe tally to determine accurate depths/lengths of the pipe string in the well bore. Torque sensors may be utilized and recorded so that the torque record shows that each connection was accurately aligned and properly torqued, and/or immediately detect/warn of any incorrectly made up connection.

[0107] FIG. 3 is a plan view of one possible embodiment of carrier **600**, mast assembly **100**, catwalk-pipe arm assembly **300** and pipe tub **400** of the long lateral completion system **10** pursuant to one possible embodiment of the present invention. The carrier **600** is illustrated with the power plant **650** and the winch or drawworks assembly **620**. The mast assembly **100** is disposed at a rear extremity of the carrier **600** and adjacent to the winch or drawworks assembly **620**. In this embodiment, base beam **120** is disposed beneath and/or adjacent to the mast assembly **100** for providing security/stability for the mast assembly **100**. Base beam **120** may comprise wide flat mats **122**, which are pushed downwardly by base beam hydraulic actuators **612** (better shown in FIG. 8A-A). In one possible embodiment, wide flat mats **122** may be 50 percent to 200 percent as wide as mast **100**. Wide flat mats **122** may fold upon each other and/or extend telescopically or slidably outwardly from carrier **600** and/or hydraulically. Wide flat mats **122** may be slidably supported on beam runner **124** and may be transported on carrier **600** or provided separately with other trucks.

[0108] In this embodiment, catwalk-pipe arm assembly **300** is affixed to mast assembly **100** and carrier **600** by rig to arm connectors **305**. In this embodiment, catwalk-pipe arm assembly **300** is shown with a pipe tub **400** on both sides of the catwalk-pipe arm assembly **300**. The pipe tubs **400** are shown with the side supports **402**, the end support **404** and a cavity **420**. A plurality of pipes (not illustrated) is placed in the pipe tubs **400**. Pipes are displaced on to the catwalk-pipe arm assembly **300** and lifted up to the mast assembly **100**. Catwalk **302** may be somewhat V-shaped or channeled to urge pipes to roll into the center for receipt and clamping utilizing catwalk-pipe arm assembly **300**. Catwalk **302** provides a walkway

surface for workers and the like. Additional pipe tubs **400** can be slid into place to provide for a continuum of pipe lengths for use by the completion system **10**. Acoustic and/or laser and/or sensors or RFID transceivers **408** and **410** may be positioned on ends **404** and sides **402** of pipe tubs **400** or elsewhere as desired to measure and/or detect the lengths of the pipes, detect RFIDs, bar codes, and/or other indicators which may be mounted to the pipes. Alternatively, pipe length sensors **412**, **414** may each comprise one or more sensors, which may be mounted to pipe arm **320**. In one embodiment, sensors **412**, **414** may comprise acoustic, electromagnetic, or light sensors which may be utilized to detect features such as length of the pipe. Pipe connection cleaning/grease injectors **416**, **418** may be provided for wire brushing, grease injecting, thread protector removal and other automated functions, if desired.

[0109] In one embodiment, sensors **412**, **414** may comprise thread protector sensors provided to ensure that the thread protectors have been removed from both ends of a pipe. Thread protectors are generally plastic or steel and used during transportation to prevent any damage to the threading of pipe. Damage as a result of faulty or damaged threads could jeopardize a well site and the safety of the workers therein. However, failing to remove a thread protector can cause the same potential dangers if not found before inserted into the pipe string. The pipe will not mate properly with the threads of the pipe string, comprising the integrity of the entire pipe string and well site. The thread protector sensors **412**, **414** may be acoustic sensors or lasers used to determine whether the thread protectors have been removed and communicate this data with the control system. If the thread protectors are present, an acoustic or light signal transmitted by **412** may be reflected rather than received at **414**. Alternatively, sensors **412** and **414** may be transceivers that will not receive a signal unless the thread protector is present. In another embodiment, a light detector will detect a different profile. In another embodiment, sensors **412** and **414** may comprise a camera in addition to other thread protector sensors. If the thread protectors have not been removed, an operator will be informed before attempting to make up the pipe connection so that the problem can be fixed.

[0110] In one possible embodiment, inner portion **406** adjacent catwalk **302** and/or catwalk edges **301** and **307** may comprise gated feed compartments whereby pipes are fed into a compartment or funnel large enough for only single pipes or stands of pipes, and then gated to allow individual pipes or stands of pipes to be automatically rolled onto either side of catwalk **302**.

[0111] FIG. 4 is an illustration of the carrier **600** of the long lateral completion system **10** of in accord with one possible embodiment of the completion system of the present disclosure. The carrier **600** is illustrated with the power plant **650** and the winch or drawworks assembly **620**. Also, the mast assembly **100** is illustrated in a lowered or horizontal, which is essentially parallel relationship with the carrier **600**. Mast **100** is clamped into the generally horizontal position with carrier front clamp/support **633** above cab **605**. Mast **100** is hinged at mast to carrier pivot **634** so that the mast is secured from any forward/reverse/side-to-side movement with respect to carrier **600** during transport after being clamped at the front and/or elsewhere. In this embodiment, mast positioning hydraulic actuators **630** are pivotally mounted with respect to carrier walkway **602** so that when extended, the hydraulic actuators **630** are angled toward the rear instead of



toward the front of carrier **600** as in FIG. **4** (See for example FIG. **2**). In one embodiment, mast positioning hydraulic actuators **630** may comprise multiple telescopically connected sections as shown in FIG. **6A**. The horizontally disposed mast assembly **100** is illustrated for moving on the highway and for arrangement in the proximate location with respect to a wellbore. It will be noted that hydraulic pipe tongs **170** are mounted to mast **100** so that when the mast **100** is lowered pipe tongs **170** are in a position generally perpendicular to the operational position. Movements and actuation of the pipe tongs can be fully automated, for forming and/or breaking both shoulder connections and collared connections. The mast assembly **100** has the crown **690** extending in front of the carrier **600**. In one embodiment, rig carrier is less than 20 feet high, or less than 15 feet high, while still allowing the rig to work with well head equipment having a height of about 20 feet. This is due to the construction of the mast with the Y-frame connection as discussed herein. The rig floor can be adjusted to a convenient height and is not necessarily fixed in height. In an embodiment, the rig floor could be connected to snubbing jacks.

[0112] FIG. **4A-A** is a top view taken along the line A-A in FIG. **4** of the mast assembly **100** of the long lateral completion system pursuant to one possible embodiment of the present invention. FIG. **4A-A** illustrates a downward view of the mast assembly **100**. The mast assembly **100** shows the top drive assembly or fixture **150** affixed to the portion of the mast assembly **100** over the winch or drawworks assembly **620** over the carrier **600**. The top drive assembly or fixture **150** is provided at the location associated with the carrier **600** for distributing the load associated with the carrier **600** for easy transportation on the highway. Top drive or fixture **150** may be clamped or pinned into position with clamps or pins **162** or the like that are inserted into holes within mast **100** at the desired axial position along the length of mast **100**. Angled struts **134** on Y-section **132**, which may be utilized in one possible embodiment of mast **100**, are illustrated in the plan view. Top drive **150** is shown with end **163**, which may comprise a threaded connector and/or tubular guide member and/or pipe clamping elements and/or torque sensors and/or alignment sensors.

[0113] FIG. **4B-B** is an end elevational view taken along the line B-B in FIG. **4** of the carrier **600** and the mast assembly **100** of the long lateral completion system **10** of in accord with one possible embodiment of the completion system of the present disclosure. FIG. **4B-B** illustrates the carrier **600**, the winch or drawworks assembly **620** and the top drive **150**. In this view, vertical top drive guide rails **104** are shown, upon which top drive **150** is guided, as discussed hereinafter. In this embodiment, it will also be noted that top drive threaded connector and/or guide member and/or clamp portion **163** is positioned in the plane define between vertical top drive guide rails **104**. In this embodiment, the view also shows one or more angled struts **134**, which may comprise Y section **132** of one possible embodiment of mast **100**, which is discussed in more detail with respect to FIG. **6A**.

[0114] FIG. **5** is an elevation view of the carrier **600**, the mast assembly **100**, and the catwalk-pipe arm assembly **300** of the long lateral completion system **10** with respect to one possible embodiment of the present invention. The carrier **600** is illustrated with the power plant **650** and the winch or drawworks assembly **620**. The cable from drawworks **620** to crown **190** is not shown but may remain connected during transportation and raising of mast **100**. The drawworks cable

may be pulled from drawworks **620** as mast **100** is raised. The mast assembly is illustrated engaged at the rear extremity of the carrier **600**. The mast assembly **100** is in a vertical arrangement such that it is at an essentially perpendicular relationship with the carrier **600**. The mast assembly **100** is illustrated with the top drive **150** in an upper position near the crown **190**. The pivotal pipe arm **320** is shown in an angled disposition slightly above catwalk **302** for clarity of view. Pivotal pipe arm **320** is shown with pipe **321** clamped thereto. The catwalk-pipe arm assembly **300** is engaged or connected via rig to arm assembly connectors **305** with the carrier **600** and the mast assembly **100**. Rig to arm assembly connectors **305** provide that the spacing arrangement between pivotal pipe arm **320** and mast **100** and/or carrier **600** is affixed so the spacing does not change during operation. Rig to arm assembly connectors **305** may comprise hydraulic operators for precise positioning of the spacing between mast **100** and pivotal pipe arm **320**, if desired.

[0115] FIG. **5A** is an enlarged or detailed view of the section identified in FIG. **5** as "A" of the rear portion of the carrier **600** engaged with a skid or mast support base beam **120** of the long lateral completion system **10** with respect to one possible embodiment of the present invention. Mast positioning hydraulic actuators **630** are provided for lowering and raising the mast assembly **100** with respect to the carrier **600** about mast to carrier pivot connection **634**. Brace **632** for Y-base or support section **130** provides additional support for mast **100**.

[0116] FIG. **6** illustrates the completion system **10** in a side elevational view with the mast assembly **100** extended in a perpendicular relationship with the carrier **600** and the pipe tubs **400** of the long lateral completion system **10** with respect to one possible embodiment of the present invention. The pivotal pipe arm **320** is angularly disposed with respect to the catwalk **302**. The mast assembly **100** is illustrated with the top drive **150** slightly below the crown **190**. Alternately, and not required in practicing the present disclosure, guy wires **101** can be engaged between the crown **190** of the mast assembly **100** and the carrier **600** on one extreme and the remote portion of a pipe tube **400** on the other extreme. However, one or more guy wires could be anchored to the ground and/or may not be utilized. One or more guy wires can also be secured to the ends of base beam **120**. It can be appreciated that the rigidity of the mast assembly **100** with respect to the carrier **600** and the base beam **120** does not require guy wires **101**. However, it may be appropriate in a particular situation or in severe weather conditions to adapt the present disclosure for use with such guy wires **101**. The carrier is illustrated with the power plant **650** and the winch or drawworks assembly **620** on the carrier deck **602**.

[0117] FIG. **6A** is an enlarged or detailed view of the portion of FIG. **6** indicated as "A" illustrating the relationship of the mast assembly **100**, the deck **602** and the base beam **120** of the long lateral completion system **10** with respect to one possible embodiment of the present invention. FIG. **6A** shows the relationship of the mast assembly **100**, the deck **602** of the carrier **600** and the base beam **120**. It will be noted that base beam widening sections **121** may extend or slide outwardly from base beam **120** and be pinned into position with pin **123**. Also illustrated is what may comprise multiple segments of mast positioning hydraulic actuators **630** for angularly disposing the mast assembly **100** in a proximately perpendicular relationship with the carrier **600**, and aligned with respect to the well bore, as discussed hereinbefore. Above the deck **602** of the carrier and affixed with the mast assembly **100** is a

hydraulic pipe tong **170**. The hydraulic pipe tong **170** is usable for handling the pipe as it is placed into a well, e.g., by receiving joints of pipe from the pipe arm and/or the top drive. The lower extremity of the mast assembly **100** includes a y-base **130**, which defines a recessed region above the wellbore at the base of the mast assembly **100**, for accommodating a blowout preventer stack, snubbing equipment, and/or other wellhead components. The recessed region enables the generally vertical mast assembly **100** to be positioned directly over a wellbore without causing undesirable contact between blowout preventers and/or other wellhead components and the mast assembly **100**.

[0118] The lower extremity of the mast assembly **100** is defined by a y-base **130**. The y-base **130** provides a disposed arrangement for making and inserting pipe using the completion system **10** of in accord with one possible embodiment of the completion system of the present invention. Y-base **130** supports Y section **132**, which extends angularly with angled strut **134** out to support one side of mast **100**. This construction provides an opening or space **136** for the BOP assembly, such as BOP (see FIG. 9), snubbing unit (see FIG. 11A), Christmas tree, well head, and/or other pressure control equipment. Mast **100** is supported by carrier to mast pivot connection **634** and at the carrier **600** rear most position by mast support plate **636**. Mast support plate **636** may be shimmed, if desired. In another embodiment, mast support plate may be mounted to be slightly moveable upwardly or downwardly with hydraulic controls to support the desired angle of mast **100**, which as discussed above may be oriented to a desired angle (e.g. less than five degrees or in another embodiment less than one degree) with respect to the axis of the bore of the well bore and/or bore of BOP **900**, shown in FIG. 9. In this embodiment, mast support plate **636** does not extend horizontally rearwardly from carrier **600** as far as the other mast **100** horizontal supports, e.g., horizontal mast supports or struts **140**. This construction allows the opening or space **136** for the BOP (see FIG. 9), snubbing unit (see FIG. 11A), Christmas tree, well head, and/or other pressure control equipment. However, the mast construction is not intended to be limited to this arrangement.

[0119] In other words, Y-base **130** back most rail **138** is horizontally offset closer to carrier **600** than back most vertical mast supports **105** with respect to carrier **600**. Y-base **130** is sufficiently tall to allow BOP stacks to fit within opening or space **136**. However, Y-base **130** is replaceable and may be replaced with a higher or shorter Y-base as desired. To accommodate the desired height of any pressure control and/or well head equipment. In this example, the bottoms of Y-base **130** may be replaceably inserted/removed from Y-base receptacles **142** to allow for easy removal/replacement of Y-base **130** from carrier **600**.

[0120] As discussed hereinafter, vertical mast supports **105** support vertical top drive guide rails **104** (see FIG. 4 B-B and FIG. 8 B-B), which guide top drive **150**. An optional raiseable/lowerable rig floor, such as rig floor **102** (See FIG. 1) is not shown for viewing convenience.

[0121] FIG. 7 is a side elevational view of the carrier **600**, the mast assembly **100**, the catwalk-pipe arm assembly **300**, and the pipe tub **400** with the mast assembly **100** (e.g., transporting a joint of pipe to the mast assembly **100** for engagement by the top drive) in a perpendicular relationship with the carrier **600**, and an arm to mast engagement element **325** of the pivotal pipe arm **320** engaged with optional upper mast fixture **135** on mast assembly **100** of the long lateral comple-

tion system **10** with respect to one possible embodiment of the present disclosure. The engagement of elements **325** and **135** may be utilized to provide an initial alignment of the pivotal connection of kick out arm **360** to pivotal arm **360**. Kick out arm **360** is shown pivotally rotated to a vertical position so that pipe **321** is aligned for connection with top drive **150**, as discussed hereinafter. The carrier **600** is illustrated with the winch assembly **620** on the deck **602**. The depicted hydraulic actuator **630** has raised the mast assembly **100** into its vertical position, as discussed hereinbefore. The mast assembly **100** is illustrated with the top drive **150** near the crown **190**. The kickout arm **360** of the catwalk-pipe arm assembly **300** may be more accurately vertically placed in the extended position adjacent to the mast assembly **100**, having a kickout arm **360** in association therewith. As such, when the pipe arm **300** pivoted into the position shown in FIG. 7 (e.g., using the hydraulic cylinder **304**), the pipe arm **300** is not parallel with the mast assembly **100**, thus a joint of pipe engaged with the pipe arm **300** would not be positioned suitably for engagement with the top drive **150**. The kickout arm **360** is extendable from the pipe arm **300** into a position that is generally parallel with the mast assembly **100**, e.g., by use of a hydraulic actuator **362**. Using the kickout arm **360** is placed in the position which is essentially parallel with the mast assembly **100**, and in this embodiment is positioned in the plane defined by mast rails **104** (See FIG. 4B-B), which guide top drive **150**, by use of the hydraulic actuator **362**. The movement of the pivotal pipe arm **320** is provided by the hydraulic actuator **304**.

[0122] In one possible embodiment, the upright position of pivotal pipe arm **320** is controlled by angular sensors **325** and/or shaft position sensor **326** to account for any variations in hydraulic operator **304** operation.

[0123] Alternatively, or in addition, upper mast fixture **135** may comprise a receptacle and guide structure. In this embodiment, which may be provided to guide the top of pivotal pipe arm **320** into contact with mast **100**, whereby the same vertical/side-to-side positioning of kick out arm **360** is assured in the horizontal and vertical directions. The guide elements may, if desired, comprise a funnel structure that guides arm to mast engagement element **325** into a relatively close fitting arrangement. If desired, a clamp and/or moveable pin element (with mating hole in pivotal pipe arm) may be utilized to pin and/or clamp pivotal pipe arm **320** into the same position for each operation. In another embodiment upper mast fixture may comprise a hydraulically operated clamp with moveable elements that clamp the pipe in a desired position for aligned engagement with top drive threaded connector and/or guide member and/or clamp portion **163**. As shown in FIG. 7A-A, upper fixture **135** may also comprise one or more pipe alignment guide members/clamps/supports as indicated at **139** to position pipe **321** and/or kickout arm **360** to thereby align pipe **321** and pipe connector **323** with respect to top drive threaded connector and/or guide member and/or clamp portion **163**. Element **139** may comprise a moveable hydraulic clamp or guide to affix and align the pipe in a particular position. Element **139** may instead comprise a fixed groove or slot or guide and may be hydraulically moveable to a laser aligned position.

[0124] As a result, top connector **323** on tubing pipe **321** is aligned to top drive threaded connector and/or guide member and/or clamp portion **163**, as discussed in more detail hereinafter, by consistent positioning of kick out arm **360**. It will be appreciated that rig to arm connectors **305** further aid

alignment by insuring that the distance between catwalk-pipe arm assembly 300 and mast 100 remains constant.

[0125] FIG. 7A-A is a rear elevational view of FIG. 7 taken along the section line A-A in FIG. 7, showing the mast assembly 100 and top drive 150 of the long lateral completion system 10 with respect to one possible embodiment of the present disclosure. FIG. 7A-A illustrates the portion of the mast assembly 100, which includes the top drive 150, and the upper portion of the pivotal pipe arm 320. Also illustrated are the lattice structural support elements 112 of the mast assembly 100. The top drive 150 is shown secured within a top drive fixture/carrier 151, which can be moved vertically along the mast assembly 100, e.g., via a rail/track-in-channel engagement using rollers, bearings, etc. Due to the generally vertical orientation of the mast assembly 100, and the positioning of the mast assembly 100 directly over the wellbore, the top drive 150 can be directly engaged with the mast assembly 100, via the top drive fixture 151, as shown, rather than requiring use of conventional cables, traveling blocks, and other features required when an angled mast is used. Engagement between the top drive 150 and the mast assembly 100 via the top drive fixture 151 eliminates the need for a conventional cable-based torque arm. Contact between the top drive 150 and the fixture 151 prevents undesired rotation and/or torquing of the top drive 150 entirely, using the structure of the mast assembly 100 to resist the torque forces normally imparted to the top drive 150 during operation.

[0126] FIG. 7B is a perspective view of the portion of the mast assembly 100 and pivotal pipe arm 320 engaged with upper fixture 135 as illustrated in FIG. 7A-A of the long lateral completion system 10 with respect to one possible embodiment of the present invention. The mast assembly 100 is illustrated with the top drive 150 positioned a selected distance the pipe arm 300.

[0127] FIG. 8 is a side elevational view of the completion system 10 in accord with another embodiment of the present disclosure illustrating the mast assembly 100 in a perpendicular relationship with the carrier 600 and/or aligned with an axis of the upper portion of the wellbore. The carrier 600 is shown with the deck 602 and the mast positioning hydraulic actuators 630 providing movement for the mast assembly 100 mast to carrier pivot connection 634. The mast assembly 100 has the top drive 150 disposed proximate to the crown 190. As discussed hereinafter, crown 190 may comprise multiple pulleys that are utilized to raise and lower the blocks associated with top drive 150 utilizing drawworks 620. The pipe arm 320 is extended in an upward position using the pipe arm hydraulic actuator 304. Further, the kickout arm 360 is disposed in a parallel relationship with the mast assembly 100 using the kick out arm hydraulic alignment actuator 362 to align pipe 321 appropriately with respect to the mast assembly 100, e.g., in one embodiment position the pipe in the plane defined between mast top drive rails 104. Mast top drive rails 104 (shown in FIG. 8B-B) are secured to an inner portion of the two rear mast (with respect to carrier 600) vertical supports 105 of mast 100.

[0128] FIG. 8A-A shows another view of Y section 132, which comprises one or more angled struts 134 on each side of mast 100 utilized to support vertical mast supports 105. Pipe tong 170 is aligned within the plane between guide rails 104 to thereby be aligned with top drive threaded connector and/or guide member and/or clamp portion 163 (see FIG. 8B-B and FIG. 4B-B) of top drive 150

[0129] FIG. 8B-B is a rear elevational view taken along the line B-B in FIG. 8 of the mast assembly 100 and top drive 150 of the long lateral completion system 10 with respect to one possible embodiment of the present invention. FIG. 8B-B illustrates the relationship of pivotal pipe arm 320, the top drive 150 and the mast assembly 100. Further, the lattice support structure 112 is illustrated for providing superior rigidity to and for the mast assembly 100.

[0130] FIG. 8C is a perspective view of FIG. 8B-B of the relationship between the pivotal pipe arm 320 and the top drive 150 relative to the mast assembly 100 of the long lateral completion system with respect to one possible embodiment of the present invention. Also illustrated is the pipe clamp 370 associated with the pivotal pipe arm 300 for holding a joint of pipe. In an embodiment, a joint of pipe raised by the pipe arm 300 then extended using the kickout arm 360 may require additional stabilization prior to threading the pipe joint to the top drive. Additional pipe clamps along the mast assembly 100 can be used to receive and engage the joint of pipe while the pipe clamp 370 of the pipe arm 300 is released, and to maintain the pipe directly beneath the top drive 150 for engagement therewith.

[0131] FIG. 8A-A is a sectional view of FIG. 8 taken along the section line A-A in FIG. 8 of the pipe tong 170 with respect to the mast assembly 100 of the long lateral completion system with respect to one possible embodiment of the present invention. FIG. 8A-A illustrates the relationship of the hydraulic pipe tong 170 with respect to the mast assembly 100 and the base beam 120. The mast assembly 100 is supported by braces 112. The braces 112 can be at various locations about the system 10 as one skilled in the art would appreciate.

[0132] FIG. 9 is an illustration of the long lateral completion system 10 of the present enclosure that depicts an embodiment relationship of the carrier 600, the mast assembly 100, catwalk-pipe arm assembly 300, the catwalk 302 and a blowout preventer and snubbing stack 900 of the long lateral completion system 10 with respect to one possible embodiment of the present disclosure. As described previously, the mast assembly 100 is disposed in a generally vertical orientation (e.g., perpendicular to the earth's surface and/or the deck 602), such that the mast assembly 100 is directly above the blowout preventer and snubbing stack 900 with the wellbore therebelow. The recessed region at the base of the mast assembly 100 accommodates the blowout preventer and snubbing stack 900, while the top drive 150 disposed near the crown 190 of the mast assembly 100 can move vertically along the mast assembly 100 while remaining directly over the well.

[0133] The mast assembly 100 can be moved and maintained in position by the hydraulic actuators 630 and/or other supports. The pipe arm 300 can be moved and maintained in the depicted raised position via extension of the hydraulic actuator 304. The kickout arm 360 pivots from the top of pivotal pipe arm using the hydraulic system 362 for aligning a joint of pipe in alignment with the well and BOP 900, which may utilize laser alignment sensors 902 mounted on BOP 900, 904 on kickout arm 360, and/or laser alignment sensors 906 on top drive 150. It should be appreciated that the kickout arm can be extended or retracted through the use of hydraulic system 362 and may be connected through manual actuation of hydraulic/pneumatics or through an electronic control system, which maybe be operated through a control van or remotely through an Internet connection. This particu-

lar embodiment implements the use of a kick-out arm **360** to provide a substantially vertical joint of pipe for reception by the mast assembly **100**, which may include a top drive of some configuration. It is important that the joint of pipe be substantially vertical so that the threads on each joint are not cross-threaded when the connection to the top drive is made. Cross-threading can lead to catastrophic failure of the connected joints of pipe or damage the threads of the joint of pipe and render the joint of pipe unusable without extensive and costly repair. As mentioned above, the pipe arm **300** can further include a centering guide, which is capable of mating with a centering receiver located on the mast assembly **100**. This centering guide and centering receiver, when used provides an additional point of contact between the pipe arm **300** and the mast assembly **100** providing additional stability to the system and more precise placement and orientation of the pipe arm and joints of pipe.

[0134] FIG. 9A-A is a sectional view taken along the section line A-A in FIG. 9 illustrating the upper portion of the mast assembly **100** of the long lateral completion system **10** with respect to one possible embodiment of the present invention. One possible embodiment of the relationship of the pipe arm **300** and the clamp **370** is shown. Also, the lattice support **112** for providing rigidity for the mast assembly **100** is illustrated. The top drive **150** is retained by the fixture **151**, which is moveably disposed along the mast assembly **100**.

[0135] FIG. 9B is a perspective view of the upper portion of the mast assembly **100** as illustrated in FIG. 9A-A, showing the top drive **150** and the upper mast fixture **135** of the long lateral completion system with respect to one possible embodiment of the present invention. The pipe arm **300** is shown below the top drive **150**. The pipe clamp **370** enables removable engagement between pipe arm **300**, and a joint of pipe, which said joint of pipe is engaged by the top drive **150**, and alternately one or more clamps or similar means of engagement along the mast assembly **100**, or other engagement systems associated with the mast assembly **100** and/or the top drive **150**, can be used to assist with the transfer of the joint of pipe from the pipe arm **300** to the top drive **150**.

[0136] FIG. 9C-C is a sectional view taken along the section line C-C in FIG. 9 illustrating the relationship of the blowout preventer and snubbing stack **900** with respect to the completion system **10** of one possible embodiment of the present invention. The blowout preventer and snubbing stack **900** is shown directly underneath the mast assembly **100**, and thus directly adjacent to the rig carrier, such that the hydraulic pipe tong **170** can be operatively associated with joints of pipe added to or removed from a string within the wellbore. The mast assembly **100** can be secured using the adjustable braces **612** attached to the base plate **120**. As another example, mast top drive guide rails **104**, which guide top drive **150** may be aligned to be essentially parallel to the axis of the bore of BOP, within less than five degrees in one embodiment, or less than three degrees, or less than one degree in another embodiment. Accordingly, top drive threaded connector and/or guide member and/or clamp portion **163** (See FIG. 4B-B) is also aligned to move up and down mast **100** essentially parallel or coaxial to the axis of the bore of BOP, within less than five degrees in one embodiment, or less than three degrees, or less than one degree in another embodiment. The blowout preventer and/or other pressure equipment may comprise pipe clamps and seals to clamp and/or seal around pipe as is well known in the art. As discussed hereinafter, a snubbing jack may comprise additional clamps and hydraulic arms for mov-

ing pipe into and out of a well under pressure, which is especially important when the pipe string in the hole weighs less than the force of the well pressure acting on the pipe, which would otherwise cause the pipe to be blown out of the well.

[0137] Specifically, the blowout preventer **900** is shown having a first set of rams **1012** positioned beneath a second set of rams **1014**, the rams **1012**, **1014** usable to shear and/or close about a tubular string, and/or to close the wellbore below, such as during emergent situations (e.g., blowouts or other instances of increased pressure in the wellbore). Above the first and second set of rams **1012**, **1014**, a snubbing assembly can be positioned, which is shown including a lower ram assembly **1016** positioned above the rams **1014**, a spool **1016** positioned above the lower ram assembly **1014**, an upper ram assembly **1018** positioned above the spool **1016**, and an annular blowout preventer **1020** positioned above the upper ram assembly **1018**. In an embodiment, the upper and lower ram assemblies **1018**, **1016** and/or the annular blowout preventer **1020** can be actuated using hydraulic power from the mobile rig, while the first and second set of rams **1012**, **1014** of the blowout preventer can be actuated via a separate hydraulic power source. In further embodiments, multiple controllers for actuating any of the rams **1012**, **1014**, **1016**, **1018** and/or the annular blowout preventer **1020** can be provided, such as a first controller disposed on the blowout preventer and/or snubbing assembly and a second controller disposed at a remote location (e.g., elsewhere on the mobile rig and/or in a control cabin). During snubbing operations, the upper and lower ram assemblies **1018**, **1016** and/or the annular blowout preventer **1020** can be used to prevent upward movement of tubular strings and joints, while during non-snubbing operations, the upper and lower ram assemblies **1018**, **1016** and blowout preventer **1020** can permit unimpeded upward and downward movement of tubular strings and joints. Typically, the annular blowout preventer **1020** can be used to limit or eliminate upward movement of tubular strings and/or joints caused by pressure in the wellbore, though if the annular blowout preventer **1020** fails or becomes damaged, or under non-ideal or extremely volatile circumstances, the upper and lower ram assemblies **1018**, **1016** can be used, e.g., in alternating fashion, to prevent upward movement of tubulars. As such, the depicted snubbing assembly (the ram assemblies **1016**, **1018** and annular blowout preventer **1020**) can remain in place, above the blowout preventer, such that snubbing operations can be performed at any time, as immediately as necessary, without requiring rental and installation of third party snubbing equipment, which can be limited by equipment availability, cost, etc. In an embodiment, the upper and lower ram assemblies **1016**, **1018** can be used as stripping blowout preventers during snubbing operations. Additionally, while the figures depict a single blowout preventer **900** having two sets of rams **1012**, **1014**, and a single snubbing assembly, in various embodiments, additional blowout preventers could be used as safety blowout preventers, which can include pipe blowout preventers, blind blowout preventers, or combinations thereof.

[0138] Due to the clearance provided in the recessed region defined by the Y-base **132** and support section **130**, the snubbing assembly can remain in place continuously, beneath the vertical mast, without interfering with operations and/or undesirably contacting the top drive or other portions of the mobile rig. Further, the clearance provided in the recessed region can enable a compact snubbing unit (e.g., snubbing

jacks and/or jaws) to be positioned above the annular blowout preventer **1020**, such as the embodiment of the compact snubbing unit **800**, described below, and depicted in FIGS. **11A** through **11D**.

[**0139**] FIG. **9C-C** also shows a first hydraulic jack **1024A** positioned at the lower end of the Y-base **132**, on a first side of the rig, and a second hydraulic jack **1024B** positioned at the lower end of the Y-base **132**, on a second side of the rig. The hydraulic jacks **1024A**, **1024B** are usable to raise and/or lower a respective side of the rig to provide the rig with a generally horizontal orientation. For example, while FIG. **1** depicts an embodiment the long lateral completion system **10** having a mast assembly **100** and a pipe handling system (e.g., skid **200**, system **300**, and tubs **400**) positioned at ground level, each component having a lower surface contacting the upper surface of the well (e.g., the earth's surface), the hydraulic jacks **1024A**, **1024B** can be used to maintain a ground level rig in an operable, horizontal orientation, independent of the grade of the surface upon which the rig is operated.

[**0140**] FIG. **10A** and FIG. **10B** provide an illustration of one possible embodiment for mounting pipe tong **170** utilizing the pipe tong fixture **172** to support pipe tong **170** at a desired vertical distance in mast **100** from BOPs, such as the blowout preventer **900** shown in FIG. **9C-C**, and with respect to a co-axial orientation with respect to the bore of the BOPs. Pipe tongs **170** may be moved in/out and up/down. The pipe tong fixture comprises one or more pipe tong vertical support rails **176**, two pipe tong horizontal movement hydraulic actuators **178** in association with a horizontal pipe support **174** for displacing the pipe tong **170**. It will be appreciated that fewer or more than two pipe tong horizontal movement hydraulic actuators **178** could be utilized. In this embodiment, horizontal support **174** may comprise telescoping and/or sliding portions, which engagingly slide with respect to each other, namely square outer tubular component **175** and square inner tubular component **177**, which move slidingly and/or telescopingly with respect to each other. In this embodiment, components **175** and **177** are concentrically mounted with respect to each other for strength but this does not have to be the case. Accordingly, pipe tong **170** is moved slidingly or telescopically horizontally back and forth as shown by comparison of FIGS. **10A** and **10B**. In FIG. **10A**, pipe tong **170** is shown in a first horizontal position moved laterally away from pipe tong vertical support rails **176**. In FIG. **10B**, pipe tong **170** is shown in a second horizontal position moved laterally or horizontally toward pipe tong vertical support rails **176**. In this way, pipe tong **170** can be moved in the desired direction to position pipe tong **170** concentrically around the pipe from the bore through BOP **900**. It will be noted that here as elsewhere in this specification, terms such as horizontal, vertical, and the like are relevant only in the sense that they are shown this way in the drawings and that for other purposes, e.g. transportation purposes as shown in FIG. **4** with the rig collapsed and hydraulic tongs oriented vertically as compared to their normal horizontal operation, hydraulic actuators **178** would then move pipe tong **170** vertically. It will also be understood that multiple tongs may be utilized on such mountings, if desired, in other embodiments of the invention, e.g. where a rotary drilling rig were utilized with the pipe tong mounting on a moveable carrier. If desired, additional centering means may be utilized to move pipe tong horizontally between vertical supports **176** to provide positioning in three dimensions

[**0141**] FIG. **10B** is a perspective view of the pipe tong fixture **172** as illustrated in FIG. **10A** of the blowout preventer with respect to the completion system of one possible embodiment of the present invention whereby pipe tong **170** is moved vertically downwardly along pipe tong vertical support rails **176**. Vertical sliding supports **179** permit pipe tong frame **181**, which comprise various struts and the like, to be moved upwardly and downwardly. Extensions **183** may be utilized in mounting support rails **176** to mast **100** and/or may be utilized with clamps associated with vertical sliding supports **179** for affixing pipe tong frame **181** to a particular vertical position. Pipe tong frame **181** may be lifted utilizing lifting lines within mast **100** and/or by connection with the blocks and/or top drive **150** and/or by hydraulic actuators (not shown).

[**0142**] FIG. **11A**, FIG. **11B**, FIG. **11C**, and FIG. **11D** illustrate one possible embodiment for a compact snubbing unit **800**, usable with the completion system **10** of the present disclosure, e.g., by securing the snubbing unit **800** above the blowout preventer and snubbing stack **900** (shown in FIG. **9**). However, snubbing unit **800** is simply shown as an example of a snubbing jack and other types of snubbing jacks may be utilized in accord with the present invention. Generally, a snubbing jack will have a movable gripper, which may be mounted on a plate that is movable with respect to a stationary gripper. At least one gripper will hold the pipe at all times. The grippers are alternately released and engaged to move pipe into and out of the wellbore under pressure. If not for this type of arrangement, when the string is lighter than the force applied by the well, the string would shoot uncontrollably out of the well. When the string is lighter than the force applied by the well, this example of snubbing jack **800** can be utilized to move pipe into or out of the well in a highly controlled manner, as is known by those of skill in the art. In another embodiment, an additional set of pulleys (not shown) might be utilized to pull top drive downwardly (while the existing cables remain in tension but slip at the desired tension to prevent the cables from swarming). Once the pipe is heavier than the force of the well, then the normally operation of top drive may be utilized for insertion and removal of pipe so long as the pipe string is preferably significantly heavier than the force acting on the pipe string. In this example, the grippers of snubbing jack **800** also provide a back up in case of a sudden increase in pressure in the well. The compact (but extendable) snubbing unit **800** can be sized to fit within the recessed region of the mast assembly **100**, to prevent undesired contact with the mast assembly **100** even when the snubbing jack is in an extended position. In this example, the depicted snubbing unit **800** includes a first horizontally disposed plate member **802**, which is a vertically moveable plate, and a second horizontally disposed plate member **804**, which is a fixed plate with respect to the wellhead, displaced by vertical columns or stanchions **806** and **808**. The lower and/or possibly upper portion of columns or stanchions **806** and **808** may comprise hydraulic jacks members which can be utilized for hydraulically moving plate member **802** upwardly and downwardly with respect to plate member **804** and may be referred to herein as hydraulic jacks **806** and **808**. Also, in this example, between the first member **802** and the second member **804** is an intermediate member **803**. In this example, between the first member **802** and the intermediate member **803** is a first engaging mechanism **820** for engaging and/or clamping and/or advancing or withdrawing pipe. Between the intermediate member **803** and the second member **804** is a second engag-

ing mechanism **830** for engaging and advancing, or withdrawing pipe. In one embodiment, both plates **802** and **803** are vertically moveable with respect to plate **804** whereby both clamps **820** and **830** are used at the same time. Accordingly, in one embodiment, both plates **802** and **803** move together. In another embodiment, grippers **820** and **830** may be moveable with respect to each other. In one possible mode of operation, the clamping mechanisms **820**, **830** can be used to grip a joint of pipe and exert a downhole force or upward force thereto, counteracting a force applied to the string due to pressure in the wellbore. Because the force of the snubbing jack unit **800** is selected to exceed the pressure from the wellbore, joints can be added or removed from a completion string even under adverse, high pressure conditions. The BOPs or other control equipment, positioned below the snubbing jack **800**, can seal around the pipe as it is moved into and out of the wellbore by snubbing jack **800**. Thus, grippers **820** and **830** may be engaged and hydraulic jacks within stanchions **806** and **808** may be expanded to remove pipe from the well or force pipe into the well. The hydraulic jacks may be contracted to move pipe into the well or pull pipe out of the well in a controlled manner. Other grippers within the BOPs may be utilized to hold the pipe, when grippers **820** and **830** are released and moveable plates **802** and/or **803** are moved to a new position for grasping the pipe to move the pipe into or out of the borehole as is known to those of skill in the art. In one embodiment of the present invention, the computer control of the control van is utilized to control the grippers **820**, **830**, and the hydraulic jacks **806** and **808**, and other grippers and seals in the BOPs to provide automated movement of the pipe into or out of the wellbore. This movement may be coordinated with that of the top drive and tongs for adding pipe or removing pipe. Thus, the entire process or portions of the process of going into the hole with snubbing units may be automated. However, it will be understood that at least two separate grippers or sets of grippers are required for a snubbing unit. If the top drive is connected to be able to apply a downward force then another stationary set of grippers is required. In addition, multiple sealing mechanisms such as rams, inflatable seals, grease injectors, and the like, may be utilized to open and close around sections of pipes so that larger joints and the like may be moved past the sealing mechanisms in a manner where at least one seal or set of seals is always sealed around the pipe string in a manner that allows sliding movement of the pipe string. The control system of the present invention is programmed to operate the entire system in a coordinated manner. In addition to or in lieu of the snubbing unit **800** and/or the snubbing assembly depicted and described above, various embodiments of the present system can include a full-sized snubbing unit, e.g., similar to a rig assist unit.

[0143] FIG. 12A depicts a schematic view of an embodiment of a control cabin **702** of the long lateral completion system **10** with respect to the present disclosure. The control cabin **702** comprises a command station **710**. The command station **710** comprises a seat **712**, control **714**, monitor **716** and related control devices. Further, the control cabin **702** provides for a second seat **715** in association with a monitor and a third seat **718** in association with yet another monitor. The control cabin **702** has doors for exiting the cabin area and accessing a walkway **720** disposed around the perimeter of the control cabin **702**.

[0144] In one embodiment, command station **710** is positioned so that once control van **700** is oriented or positioned

with respect to mast **100** (See FIG. 1), carrier **600**, catwalk and pipe handling assembly **300**, and/or pump/pit **500**, then all mast operations can be observed through command station front windows **730** as well as command station top windows **732**. Front windows **730**, for example, allow a close view of rig operations at the rig floor. Top windows **732** allow a view all the way to the top of mast **100**. In one embodiment, additional command station side and rear windows **740**, side windows **742**, **744** will allow easy observation of other actions around mast **100**. If desired, control van **700** may be positioned as shown in FIG. 1 and/or adjacent pump/pit combination skid **500**. If desired, additional cameras may be positioned around the rig to allow direct observation of other components of the rig, e.g., pump/pit return line flow or the like.

[0145] The control van **700** may include a scissor lift mechanism to lift and adjust the yaw of command station **710**. A scissor lift mechanism is a device used to extend or position a platform by mechanical means. The term "scissor" is derived from the mechanism used, which is configured with linked, folding supports in a crisscrossed "X" pattern. An extension motion or displacement motion is achieved by applying a force to one of the supports resulting in an elongation of the crossing pattern supports. Typically, the force applied to extend the scissor mechanism is hydraulic, pneumatic or mechanical. The force can be applied by various mechanisms such as by way of example and without limitation a lead screw, a rack and pinion system, etc.

[0146] For example with loading applied at the bottom, it is readily determined that the force required to lift a scissor mechanism is equal to the sum of the weights of the payload, its support, and the scissor arms themselves divided by twice the tangent of the angle between the scissor arms and the horizontal. This relationship applies to a scissor lift mechanism that has straight, equal-length arms, i.e., the distance from an actuator point to the scissors-joint is the same as the distance from that scissor-joint to the top load platform attachment. The actuator point can be, by way of examples, a horizontal-jack-screw attachment point, a horizontal hydraulic-ram attachment point or the like. For loading applied at the bottom, the equation would be  $F=(W+W_a)/2 \tan \Phi$ . The terms are  $F$ =the force provided by the hydraulic ram or jack-screw,  $W$ =the combined weights of the payload and the load platform,  $W_a$ =the combined weight of the two scissor arms themselves, and  $\Phi$  is the angle between the scissor arm and the horizontal.

[0147] And for loading applied at the center pin of the crisscross pattern, the equation would be  $F=W+(W_a/2)/\tan \Phi$ . The terms are  $F$ =the force provided by the hydraulic ram or jack-screw,  $W$ =the combined weights of the payload and the load platform,  $W_a$ =the combined weight of the two scissor arms themselves, and  $\Phi$  is the angle between the scissor arm and the horizontal.

[0148] FIG. 12B is an elevation view of the control cabin **702** of the completion system **10** of one possible embodiment of the present invention. The command station **710** the walkway **720** and exterior controls **726**.

[0149] FIG. 12C is an end view of the control cabin **702** of the completion system **10** of one possible embodiment of the present invention. FIG. 12C illustrates the command station **710** in association with the control cabin **702**. The walkway **720** is also illustrated.

[0150] FIG. 12D is an end view of the control cabin **702** taken from the alternate perspective as that of FIG. 12C of the

completion system of one possible embodiment of the present invention. The outer controls 726 are illustrated.

[0151] FIG. 13 is an illustration of the carrier 600 adapted for use with the completion system 10 of one possible embodiment of the present invention. The carrier comprises a cabin 605, a power plant 650, and a deck 610. Foldable walkway 602 folds up for transportation and then when unfolded extends the walkway space laterally to the side of carrier 600. Winch assembly 620 can be mounted along slot 622 at a desired axial position at any desired axial position along the length of carrier 600. Winch or drawworks assembly 620 may or may not be mounted to a mounting such as mounting 624, which is securable to slot 620. Mounting 624 may be utilized for mounting an electrical power generator or other desired equipment. Recess 626 may be utilized to support mast positioning hydraulic actuators 630, which are not shown in FIG. 13. One or more stanchions 614 (e.g., a Y-base) are illustrated for engaging the mast assembly 100 with the carrier 600.

[0152] FIG. 14 is an illustration of the catwalk-pipe arm assembly 300 of the completion system 10 of one possible embodiment of the present invention. The catwalk-pipe arm assembly 300 is illustrated with a ground skid 310, pipe arm hydraulic actuators 304 for lifting the pivotal pipe arm 320 and the kickout arm 360 attached thereto. The kickout arm 360 can subsequently be extended the central pipe arm 320 using additional hydraulic cylinders disposed therebetween.

[0153] In yet another embodiment, a pivotal clamp could be utilized at 312 in place of the entire kick arm 360 whereby orientation of the pipe for connection with top drive 150 may utilize upper mast fixture 135 and/or mast mounted grippers and/or guide elements.

[0154] In one embodiment, catwalk 302 may be provided in two elongate catwalk sections 309 and 311 on either side of pivotal pipe arm 320 for guiding pipe to and/or away from pivotal pipe arm 320. However, only one elongate section 309 or 311 might be utilized. Catwalk 302 provides a walkway and a catwalk is often part of a rig, along with a V-door, for lifting pipes using a cat line. To the extent desired, catwalk 302 may continue provide this typical function although in one possible embodiment of the present invention, pivotal pipe arm 320 is now preferably utilized, perhaps or perhaps not exclusively, for the insertion and removal of tubing from the wellbore.

[0155] In one possible embodiment of catwalk 302, each catwalk section 309 and 311 may comprise multiple catwalk pipe moving elements 314 which move the pipes toward or away from pivotal pipe arm 320 and otherwise are in a stowed position, resulting in a relatively smooth catwalk walkway. Referring to FIGS. 15F and F 15G, FIG. 21A, and FIG. 21B, catwalk pipe moving hydraulic controls 333 may be utilized to independently tilt catwalk pipe moving elements 314 upwardly or downwardly, as indicated. On the left of FIG. 15F, catwalk pipe moving element 314 is in the stowed position flat with catwalk 309. On the right of FIG. 15F, catwalk pipe moving element 314 is tilted inwardly to urge pipes toward pivotal pipe arm 320. In FIG. 15G, catwalk pipe moving elements are both tilted away from pipe moving element 314 to urge pipes away from pivotal pipe arm 320. However, each group of catwalk pipe moving elements 314 on each of catwalks 309 and 311 operate independently. In one embodiment, by tilting pipe moving elements 314 away from pivotal pipe arm 320, the pipe moving elements 314 operate in synchronized fashion with pipe ejector direction

control which directs pipe away from pipe arm 320 in a desired direction as indicated by arrows 377A and 377B (see FIG. 17), as discussed hereinafter.

[0156] In another embodiment, each entire elongate catwalk section 309 and 311 could be pivotally mounted on skid edges 301 and 307. Accordingly, due to the pivotal mounting discussed previously or in accord with this alternate embodiment, catwalk sections 309 may be selectively utilized to urge pipes toward or away from pivotal pipe arm 320. However, in yet another embodiment the catwalks may also be fixed structures so as to either slope towards or away from pivotal arm 320 or may simply be relatively flat.

[0157] In yet another embodiment, at least one side of catwalk 302 (catwalk sections 309 and/or 311) may be slightly sloped inwardly or downwardly toward pivotal pipe arm 320 to urge pipe toward guide pipe for engagement with pivotal pipe arm 320. In one embodiment, pipe tubs 400 and/or one or both sides of catwalk 302 (and/or catwalk pipe moving elements 314) include means for automatically feeding pipes onto catwalk 302 for insertion into the wellbore, which operation may be synchronized for feeding pipe to or ejecting pipe from pivotal pipe arm 320. In another embodiment, at least one side of catwalk 302 and/or catwalk pipe moving elements 314, may also be slightly sloped slightly downwardly towards at least one of pipe tubs 400 to urge pipes toward the respective pipe tub when pipe is removed from the well. In one embodiment, one pipe tub may be utilized for receiving pipe while another is used for feeding pipe. In another embodiment, catwalk 302 may simply provide a surface with elements (not shown) built thereon for urging the pipe to or from the desired pipe tub 400.

[0158] In yet another embodiment, catwalk 302, which may or may not be pivotally mounted and/or comprise catwalk pipe moving elements 314, may be provided as part of the pipe tub and may not be integral or built onto the same skid as pivotal pipe arm 320. In yet another embodiment, the pipes may be manually fed to and from the pipe tubs or pipe racks to pivotal pipe arm 320 via catwalk 302.

[0159] FIG. 14A is a blowup view of the lower pipe arm pivot connection 313 upon which the pivotal pipe arm 320 is lifted for the catwalk-pipe arm assembly 300. The lower pipe arm pivot connection 313 comprises a bearing 306 and a shaft or pin 308 which provides a pivot point for the pivotal pipe arm 320 with respect to the pipe arm ground skid 310.

[0160] FIG. 15A is an elevation view of the catwalk-pipe arm assembly 300 of the completion system 10 of one possible embodiment of the present invention. The catwalk-pipe arm assembly 300 comprises the central arm 320, a kickout arm 360 and one or more clamps 370A, 370B, 370C for engaging a pipe "P." The catwalk-pipe arm assembly 300 is rotationally moved or pivoted with respect to lower pipe arm pivot connection 313 using the hydraulic actuators 304. In this embodiment, pivotal pipe arm 320 comprises a grid comprising plurality of pipe arm struts 364.

[0161] FIG. 15B is an enlarged or detailed view of the section "B" of pivot connection 313 as illustrated in FIG. 15A of the completion system of one possible embodiment of the present invention. The pivotal pipe arm 320 is pivotally moved using a bearing 306 in association with a shaft or pin 308. Control arm 315, to which pivot arm struts 317 (See also FIG. 15A) are affixed, pivots about lower pipe arm pivot connection 313.

[0162] FIG. 15C is an enlarged or detailed view of section "C" illustrated in FIG. 15A of the completion system of one

possible embodiment of the present invention, which shows control arm to hydraulic arm pivot connection 319. Piston 323 of the hydraulic cylinder of hydraulic actuator 304 is pivotally engaged with control arm 315 using the pin 327.

[0163] FIG. 15D is an enlarged or detailed view of the section indicated by “D” in FIG. 15A of the completion system of one possible embodiment of the present invention, which shows the hydraulic cylinder of hydraulic actuator 304 pivotally connected to 329. FIG. 15D shows the engagement of the hydraulic cylinder with the skid using the pin 331.

[0164] FIG. 15E is a plan view of the catwalk-pipe arm assembly 300 of the completion system 10 of one possible embodiment of the present invention. The catwalk-pipe arm assembly 300 comprises the pivotal pipe arm 320 in association with the skid 310. The arm has engaged with it a kickout arm 360 which is pivotally moved with the hydraulic actuator 362. The pivotal pipe arm 320 is pivotally moved with the hydraulic actuator 304. The kickout arm has clamps 370 for engaging a piece of pipe “P”.

[0165] FIG. 16A is an elevation view of the pivotal pipe arm 320 of the completion system 10 of the completion system 10 of one possible embodiment of the present invention, without the catwalk 302 for easier viewing. Pivotal pipe arm 320 comprises an elongate lower pipe arm section 322 which is pivoted using the hydraulic actuators 304. Lower pipe arm section 322 is secured to y-joint connector 324, which in turn connects to pivot arm Y arm strut components 326A and 326B. The Y arm strut components 326A and 326B are connected to control arms 315, which are in moveable engagement with the hydraulic actuators 304. An extension (not shown) may be utilized to engage upper mast fixture 135, if desired, to provide a preset starting position from which kickout arm 360 pivots outwardly to align with the top drive 150.

[0166] The elongate kickout arm 360 secures a piece of pipe “P” using a plurality of pipe clamps 370, which are labeled 370A and 370B at the bottom and top (when upright) of kickout arm 360. Pipe ejector directional control 371 acts to eject the pipe from pivotal arm 320 in a desired direction when the pipe is laid down adjacent catwalk 302, as discussed hereinafter.

[0167] FIG. 16B is a plan view of the pivotal pipe arm 320, as illustrated in FIG. 16A for the completion system 10 of one possible embodiment of the present invention, showing only the pipe arm components for convenience. In one possible embodiment, upper pipe arm section 340 may also incorporate kickout arm 360. In this embodiment, kickout arm 360 remains generally parallel to pivotal pipe arm 360 except when pivotal pipe arm 360 is moved into the upright position shown in FIG. 7, FIG. 8, and FIG. 9. Upon reaching the upright position, kickout arm 360 is pivoted using the hydraulic actuators 362, which cause kickarm 360 to pivot away from pipe arm 360 about kick arm pivot connection 312 (FIG. 16C) at the top of pivotal pipe arm 360. The kickout arm 360 is shown with the clamps 370A and 370B at the bottom and top (when vertically raised) of kickout arm 360 as well as pipe ejector directional control 371, which may be positioned more centrally, if desired.

[0168] FIG. 16C is an enlarged or detailed view of the section “C” as illustrated in FIG. 16A for the completion system 10 of one possible embodiment of the present invention, which shows kick arm pivot connection 312 (FIG. 16C) at the top of pivotal pipe arm 360. FIG. 16C shows the pivotal pipe arm 320 in association with an upper portion of kickout arm 360 (when vertically raised) and the clamp 370B.

[0169] FIG. 16D is an end view of the pivotal pipe arm 320 and kickout arm 360 of the completion system 10 of one possible embodiment of the present invention for the completion system 10, which shows an end view kick arm pivot connection 312 (FIG. 16C) at the top of pivotal pipe arm 360 and clamp 370B. Pivot beam 366 connects pipe kickout arm 360 to the top of pivotal pipe arm 320. Kickout arm base 375 may comprise a rectangular cross-section in this embodiment. The pipe is received into pipe reception groove 378.

[0170] FIG. 17 is a perspective view of a portion of the kickout arm 360 of the completion system 10 of in accord with one possible embodiment of the present invention. The kickout arm 360 is illustrated with the components attached to a kick out arm base 375, which in this embodiment may have a relatively rectangular or square profile. The kick out arm base 375 is used for supporting one possible embodiment of the pipe clamps 370A and 370B (See also FIG. 18A) and pipe ejector directional control 371. Torsional arms 372, which are also referred to as torsional arms 372A and 372B, are utilized to selectively activate eject arms 374A and 374B. The eject arms 374A connect to torsional arms 372A. The eject arms 374B connect to torsional arms 372B, respectively. When torsional arms 372A are rotated utilizing hydraulic actuator 382A, which rotates plates 384A, (see FIG. 17A and FIG. 18 C-C), then eject arms 374A will lift the pipe to eject the pipe from kickout arm 360 in the direction shown by pipe ejection direction arrow 377A to the pipe tub or the like. Similarly, when torsional arms 372B are rotated, then eject arms 374B eject the pipe in the direction indicated by pipe ejection direction arrow 377B to the other side. Prior to ejection or clamping, the pipe will align with the pipe reception grooves 378 in the clamps 370 and ejector mechanism 380. Plates 375 comprise a relatively square receptacle 385 (see FIG. 17A) that mates to kick out arm base 375 for secure mounting to resist torsional forces created during pipe ejection and/or pipe clamping.

[0171] FIG. 17A and FIG. 18C-C provide an enlarged or detailed view of the pipe ejector directional control 371 illustrated in FIG. 17 for the completion system of one possible embodiment of the present invention. The pipe ejector directional control 371 is illustrated using the plates 376 in association with the torsional ejection rods 372A and 372B. The ejection mechanisms 380A and 380B (see FIG. 18 C-C) is between the plates 376 and provides for rotational movement of the torsional ejection rods 372A and 372B. Ejection mechanism 380A operates to eject pipe as indicated by pipe ejection direction arrow 377A (see FIG. 17). Ejection mechanism 380B operates to eject pipe in the direction indicated by arrow 377B. The pipe reception groove 378 is for accepting the joint of pipe during clamping or prior to ejection. In this embodiment, ejector hydraulic actuators 382A and 382B are pivotally connected to pivotal plates 384A and 384B, respectively, which are fastened to respective torsional ejection rods 372A and 372B for selectively ejecting the pipe from kickout arm 360 in the desired direction as indicated by pipe ejection arrows 377A and 377B. As shown in FIG. 17, torsional ejection rods 372A and 372B are rotationally mounted to plates on clamps 370A and 370B for support at the ends thereof.

[0172] Referring to FIG. 17, FIG. 18C, FIG. 21A, and FIG. 21B, clamps 370A and 370B are similar and in this embodiment each comprises two sets of clamping members, lower clamp set 387A,B and upper clamp set 389 A,B. Each clamp set is activated by respective pairs of clamp hydraulic actuators, such as 392A and 392B, perhaps best shown in FIG.



**18A.** In this embodiment, after the pipe is rolled into the pipe reception grooves, then the clamp sets **387A**, **389A** and **387B**, **389B** are pivotally mounted on clamp arms **394A** and **394B** to rotate upwardly around pivot connections to clamp the pipes. When not in use clamp sets **387A**, **389A** and **387B**, **389B** are rotated downwardly to be out of the way (as shown in FIGS. **17** and **21A**) as the pipes are rolled into the pipe reception grooves **378**.

**[0173]** It will be appreciated that other types of clamps, arms, ejection mechanisms and the like may be hydraulically operated to clamp and/or eject the pipe onto or away from kickout arm **360**.

**[0174]** FIG. **18A** is an elevation view of the kickout arm **360** of the completion system **10** in accord with one possible embodiment of the present invention. The kickout arm **360** is shown with the lower and upper pipe clamps **370A** and **370B**, pipe ejector direction control **371**, torsional ejection rod **372A**, and pipe clamp hydraulic actuators **392A**.

**[0175]** FIG. **18B** is a bottom view of the kickout arm **360** as illustrated in FIG. **18A** for the completion system of one possible embodiment of the present invention. FIG. **18B** illustrates the base **375** in association with the torsional ejection rods **372A** and **372B**, which in this embodiment are rotationally secured to each of clamps **370A** and **370B** as well as to pipe ejector direction control **371**. The clamps **370A** and **370B** are dispersed at the remote ends of the kickout arm **360**. There may be fewer or more clamps, as desired.

**[0176]** FIG. **18C** is a top view of the kickout arm **360** of the completion system **10** of the present invention. The kickout arm **360** is illustrated with the clamps **370A** and **370B** secured with the base **375** and operatively associated with the torsional ejection rods **372A** and **372B**.

**[0177]** FIG. **18B-B** is a sectional view of the end taken along the section line B-B in FIG. **18B** for the completion system of one possible embodiment of the present invention. The end **390** is illustrated with kick arm pivot connection **312** at the top (when pivotal pipe arm is upright) of pivotal pipe arm **320**.

**[0178]** FIG. **18C-C** is a cross section taken along the section line C-C in FIG. **18C** illustrating pipe ejector direction control **371**. The ejector mechanism **380A** and **380B** comprise ejector hydraulic actuators **382A**, **382B** and pivotally mounted ejection control arms **384A** and **384B**, which rotate torsional ejection rods **372A**, and **372B** in one possible embodiment of the present invention.

**[0179]** FIG. **19A** is an elevation view of the top drive fixture **151**, without the top drive mechanism **160**, used in conjunction with the mast assembly **100** of the completion system **10** of one possible embodiment of the present invention. The top drive fixture **151** is shown with the guide frame **152**, separated designated as **152A**, **152B**. Guide frames **152A**, **152B** are connected at top drive fixture flanges **141A**, **141B** to extensions **143A**, **143B** downwardly projecting from side plates **156A**, **156B** of a traveling block frame **154**. Traveling block fixture **154** is part of a traveling block assembly **153** comprising frame **154** and a cluster of sheaves **155** supported in such frame. Guide frames **152A**, **152B** slidingly engage mast top drive guide rails **104**, as discussed hereinbefore.

**[0180]** FIG. **19B** is a side view of the top drive fixture **151** and frame **154** of the traveling block assembly **153** illustrated in FIG. **19A**. FIG. **19B** illustrates the guide frame **152B** in relation to the traveling block frame **154B** using the block side plate **156B**.

**[0181]** FIG. **19C-C** is a cross sectional view taken along the section line C-C in FIG. **19B** illustrating the mechanism associated with the top drive fixture **151** of the completion system of one possible embodiment of the present invention. The mechanism provides for the slide supports **152** having at its extremities a first and second rollers **158A**, **158B** on a respective roller axles **159A**, **159B** of guide frame **152B**, which may be utilized to provide a rolling interaction with mast top drive guide rails **104** maintaining the top drive in a relatively fixed vertical position. FIG. **19C-C** also depicts flange **141B** connected to extension **143B**.

**[0182]** FIG. **19D** is an enlarged or detailed view of the roller **158A** as illustrated in FIG. **19B**.

**[0183]** FIG. **19E-E** is a cross sectional view taken along the section line E-E in FIG. **19A**. **19E-E** is in the same orientation as FIG. **19B**, but is sectional. Referring to FIGS. **19A**, **19B** and **19E-E**, traveling block frame **154** further comprises a front plate **144A**, a rear plate **144B**, and side plates **156A**, **156B** including the downwardly projecting extensions **143A**, **143B**. A frame cross member **145** spans side plates **156A**, **156B** above traveling block sheaves **155A**, **155B**, **155C**, **155D** sufficiently within parallel planes tangent to peripheries of flanges of such sheaves that a drilling line reeved around the sheaves as described below does not contact cross member **145**. Cross member **145** mounts inferiorly a plurality of rigid spaced apart parallel hangers **146A**, **146B**, **146C**, **146D** and **146E**, each in a plane perpendicular to an axis of front sheaves of a crown block assembly described below. Hangers **146A**, **146B** support between them an axle **147A** for traveling block sheave **155A**; hangers **146B**, **146B** support between them an axle **147B** for traveling block sheave **155B**; hangers **146C**, **146D** support between them an axle **147C** for traveling block sheave **155C**; and hangers **146D**, **146E** support between them an axle **147D** for traveling block sheave **155D**. Each sheave axle **147A**, **147B**, **147C** and **147D** is parallel to the plane of the axis of the front sheaves of the crown block assembly. Traveling block sheaves **155A**, **155B**, **155C**, **155D** rotate in traveling block frame respectively on axles **147A**, **147B**, **147C** and **147D**.

**[0184]** FIG. **20A** is an illustration of the top drive **150** in the top drive fixture **151** of the completion system of one possible embodiment of the present invention. The top drive comprises the top drive fixture **151** in conjunction with the drive mechanism **160**. The drive mechanism **160** is moveably engaged with the guide frames **152A**, **152B** and moves in a vertical direction using traveling block assembly **153**. A top drive shaft **165** provides rotational movement of the pipe using the drive mechanism **160**. Top drive shaft **165** connects to item **163**, which may comprise a top drive threaded connector and/or pipe connection guide member. Item **163** may also be adapted to hold the pipe. A torque sensor may also be included therein.

**[0185]** FIG. **20B** is an upper view of traveling block assembly **153** and top drive **150** as illustrated in FIG. **20A**. FIG. **20B** illustrates the guide frames **152A**, **152B** with the frame **154** there between.

**[0186]** Referring to FIGS. **19A**, **19B**, **19E-E**, **20A** and **20B**, traveling block sheaves **155** are seen to be horizontally canted in frame **154**. The purpose and angle of this canting and the operation of the traveling block assembly to raise and lower top drive **150** is now explained.

**[0187]** Referring to FIGS, carrier **600** pivotally mounts mast **100** on the carrier for rotation upward to an erect drilling position, as has been described. Mast **100** comprises front and

rear vertical support members **105**, and a mast top or crown **190** supported atop front and rear vertical support members **105**. Drawworks **620** is mounted on carrier **600** to the rear of an erect mast **100**. Drawworks **620** has a drum **621** with a drum rotation axis perpendicular to the drilling axis for winding and unwinding a drilling line on drum **621**. A crown block assembly **191** is mounted in mast top or crown **190** for engaging the drilling line. The crown block assembly comprises a cluster **193** of front sheaves mounted at the front of mast top **190** facing the drilling axis. This cluster **193** comprises first and second outermost sheaves and at least one inboard sheave, all aligned on an axis in a plane perpendicular to the drilling axis and having a predetermined distance between grooves of adjacent front sheaves. A fast line sheave **194** is mounted on the drawworks side of the mast top behind the first outermost front sheave of cluster **193** and on an axis substantially parallel to the axis of the front sheaves of cluster **193**, for reeving the drilling line to the first outermost front sheave of cluster **193**. A deadline sheave **195** (blocked from view by the front sheaves of cluster **193**) is mounted on the drawworks side of mast top **190** behind a second laterally outermost front sheave (blocked from view by fast line sheave **194**) and on an axis substantially parallel to the axis of the front sheaves of cluster **193**, for reeving the drilling line from the second outermost front sheave to an anchorage.

**[0188]** Traveling block assembly **153** hangs by the drilling line from the front sheaves of the crown block assembly, and comprising, as has been described, fixture **154** and the cluster of sheaves **155** supported in the fixture. The cluster is one less in number than the number of front sheaves in the crown block assembly and includes at least first and second outermost traveling block sheaves **155A**, **155D** (in the illustrated embodiment there are two traveling block sheaves, **155B**, **155C** inboard of outermost traveling block sheaves **155A**, **155D**). Traveling block sheaves **155A**, **155B**, **155C**, **155D** have a predetermined distance between grooves of adjacent traveling sheaves and rotate on a common horizontal axis in a plane perpendicular to the drilling axis. The axis of the traveling sheaves **155A**, **155B**, **155C**, **155D** is angled in the latter plane relative to the axis of the front sheaves of the crown block assembly such that the drilling line reeves downwardly from the groove in a first front sheave parallel to the drilling axis to engage the groove in a first traveling block sheave and reeves upwardly from the groove in a first traveling block sheave toward the second front sheave next adjacent such first front sheave at an up-going drilling line angle to the drilling axis effective according to the distance between the grooves of the first and second front sheaves to move the drilling line laterally relative to the front sheave axis and engage the groove of the second front sheave, each the traveling block sheaves receiving the drilling line parallel to the drilling axis and reeving the drilling line to each following front sheave at an up-going angle.

**[0189]** Accordingly, first outermost traveling block sheave **155A** receives the drilling line reeved downward from the first laterally outermost front sheave of the crown block assembly parallel to the drilling axis and reeves the drilling line at an up-going angle to a next adjacent inboard front sheave. The latter inboard front sheave reeves the drilling line downward to traveling block sheave **155B** next adjacent first laterally outermost traveling block sheave **155A** parallel to the drilling axis. The latter traveling block sheave **155B** reeves the drilling line at an up-going angle to a front sheave next adjacent the front sheave next adjacent the first laterally

outermost front sheave, and so forth, for each successive traveling block sheave (respectively sheaves **155C**, **155D** in the illustrated embodiment of FIGS. **19A**, **19B**, **19E-E**, **20A** and **20B**), until the second outermost traveling block sheave (**155D** in the illustrated embodiment) reeves the drilling line at an the up-going angle to the second outermost front sheave. The second outermost front sheave reeves the drilling line to the deadline sheave, and the deadline sheave reeves the line to the anchorage.

**[0190]** In an embodiment, an up-going angle from a traveling block sheave to a crown block front sheave is not more than about 15 degrees. In an embodiment, an up-going angle from a traveling block sheave to a crown block front sheave is about 12 degrees.

**[0191]** In an embodiment, the predetermined distances between grooves of the front sheaves are equal from sheave to sheave. In an embodiment in which the front sheaves comprise a plurality of inboard sheaves, the predetermined distance between at least one pair of inboard front sheaves may be the same or different than the distance separating an outermost front sheave from a next adjacent inboard front sheave.

**[0192]** FIG. **20A-A** is a cross sectional view taken along the section line A-A in FIG. **20A** illustrating the relationship of the drive mechanism **160** in the top drive frame **151**. The guide frames **152** provide structural support for the drive mechanism **160**.

**[0193]** FIG. **21A** is a perspective view of the pipe arm assembly with the pipe clamps recessed allowing the pipe arm to receive pipe, as also previously discussed with respect to FIG. **17**, and FIG. **18C**. In this embodiment, pipe ejector direction control **371** is omitted for clarity of the other elements in the figure. However, in another possible embodiment, the pipe ejector mechanism may not be utilized or may be replaced by other pipe ejector means. Kickout arm **360** is secured to pivotal pipe arm **320** at kickout arm pivot connection **312** located at the top of pivotal pipe arm **320**. Kickout arm hydraulic actuators **362** provide pivotal movement when pipe arm **320** is in an upright position. In this embodiment, pipe clamps **370A** and **370B** are mounted to kickout arm **360**, although in other embodiments pipe clamps **370A** and **370B** can be mounted directly to pivotal pipe arm **320**. Catwalk segments **309** and **311** contain one possible embodiment of catwalk pipe moving elements **314** to urge pipe onto pipe arm **320** which are guided or rolled into pipe reception grooves **378** along pipe guides **379** (See FIG. **16D**). Pipe clamp sets **387A**, **389A** and **387B**, **389B** are recessed below an outer surface of pipe guides **379** within pipe clamp mechanisms **370A** and **370B** to allow pipe P to be accepted in pipe reception grooves **378**, such as pipe P which is shown in position in the pipe reception grooves. Pipe clamp sets **387A**, **389A** and **387B**, **389B** are mounted to pivotal pipe clamp arms **394A** and **394B**.

**[0194]** FIG. **21B** is a perspective view of the pipe arm assembly with the pipe clamps engaged around the pipe, which allows the pipe arm to move the pipe P to an upright position in mast **100**. In this embodiment, pipe clamp **370A** is located at a lower point on kickout arm **360**, while pipe clamp **370B** is located on an upper part of kickout arm **360**. In another embodiment, pipe clamps **370A** and **370B** could be mounted to pipe arm **320**. As discussed hereinbefore, pipe clamp sets **387A**, **389A** and **387B**, **389B** are mounted to pivotal pipe clamp arms **394A** and **394B**. In this embodiment, once pipe P is urged into pipe receptacle grooves **378** by

catwalk moving elements 314 on either catwalk section 309 or 311, pipe clamp hydraulic actuators 392A and 392B (See FIG. 18C) urge pipe clamp sets 387A, 389A and 387B, 389B around clamp pivots 391A and 391B to engage pipe P.

[0195] FIG. 22A is a perspective end view of one possible embodiment of walkway 309 and 311 with one possible example moving elements, illustrating how pipe is moved from the walkway to the pipe arm. In FIG. 22A, catwalk segment 311 contains catwalk pipe moving elements 314 in a sloped position for urging pipe P into pipe clamp mechanisms 370A and 370B utilizing pipe reception grooves 378. In another embodiment, catwalk pipe moving elements 314 can move into a second sloped position for moving pipe away from kickout arm 360 towards a pipe tub. In this embodiment, corresponding pipe moving element hydraulic controls 333 can be utilized for selectively operating pipe moving elements 314 on catwalk segments 309 and 311 (See FIG. 15F). For example, the moving elements can be retracted below the surface of walkway 311 or raised to provide a gradual slope that urges the pipes into pipe reception grooves 378.

[0196] In one possible embodiment, pipe barrier posts 316 may be utilized to prevent additional pipes from entering catwalk segment 311 while pipe is being moved with pipe moving elements 314 towards pipe clamp mechanisms 370A and 370B located on kickout arm 360. Pipe barrier posts 316 may keep the pipe outside of the catwalk segment 311 after pipe moving elements 314 are lowered, whereby an operator may walk along the catwalk without impediments and/or utilize the catwalk for other purposes such as making up tools or the like. Catwalk segment 309 illustrates pipe moving elements 314 in a flat position flush with the surface of catwalk segment 309. In one possible embodiment, pipe barrier posts 316 may be hydraulically raised and lowered. In another embodiment pipe barrier posts 316 may mechanically inserted, removed, or replaced (such as with sockets in the catwalk). In another embodiment, pipe barrier posts may not be utilized. In another embodiment, other means for separating the pipe may be utilized to urge a single pipe on pipe moving elements whereupon catwalk moving elements 314 are raised to gently urge one or more pipes into pipe reception grooves 378. Catwalk pipe moving elements may be larger or wider if desired. In another embodiment, catwalk pipe moving elements may comprise a groove that holds the next pipe until raised whereupon the pipes are urged toward pipe guides 379 and pipe reception grooves 379.

[0197] FIG. 22B is a perspective end view of the walkway with movable elements in accord with one possible embodiment of the invention. Catwalk segment 309 contains pipe moving elements 314 in a recessed position with pipe barrier posts 316 to prevent pipe from entering catwalk segment 309 while pipe P is engaged with pivotal pipe arm 320. In this embodiment, catwalk segment 311 illustrates pipe moving elements 314 in a raised position that work with pipe barrier posts 316 to prevent pipe from entering catwalk segment 311. In other embodiments, pipe barrier posts 316 may be hydraulically actuated or manually removable. In another embodiment, pipe barrier posts may be omitted and pipe moving elements 314 may contain a groove for holding back pipe from pipe tub 400. Kickout arm 360 is secured to pivotal pipe arm 320 at kickout arm pivot connection 312 located at the top of pivotal pipe arm 320. Pipe P has rolled into pipe reception grooves 378 located in pipe clamp mechanisms 370A and

370B where pipe clamp sets 387A, 389A and 387B, 389B will pivot about pivotal pipe clamp arms 394A and 394B to engage pipe P.

[0198] FIG. 23A is an end perspective view of a pipe feeding mechanism in accord with one possible embodiment of the invention. In this embodiment, pipe tub 400 comprises a rack or support, at least a portion of which is sloped downward towards catwalk segment 311 which urges pipe towards pipe feed receptacle 424. Pipe feed receptacle 424 is movably mounted to support arms 434 for transporting pipe between pipe tub 400 and catwalk segment 311. Accordingly, in one embodiment, pipe receptacle 424 lifts pipe one at a time out of pipe tub 400 onto catwalk 311 and/or catwalk moving elements 314. As used herein pipe tube 400 may comprise a volume in which multiple layers of pipe may be conveniently carried or may simply be a pipe rack with a single layer of pipe.

[0199] FIG. 23B is another end perspective view of a pipe feeding mechanism in accord with one possible embodiment of the present invention. Pipe feed mechanism 422 comprises support arms 434 which, if desired, may be fastened to catwalk segment 311. In one possible embodiment, pipe feed receptacle may comprise a wall, rods, brace 425 at edge 427 of pipe feed receptacle adjacent the incoming pipe that contains the remaining pipe on the rack when pipe feed receptacle 424 moves, in this embodiment, upwardly. Thus, the wall or rods act as a gate. Once pipe receptacle 424 is lowered, then another pipe drops into pipe receptacle 424. In this embodiment, pipe feed receptacle 424 is slidably mounted to support arms 434 for movement between pipe tub 400 and catwalk segment 311. Once pipe P is moved towards catwalk segment 311, catwalk moving elements 314 urge pipe P towards pipe arm 320 with kickout arm 360. Pipe feed receptacle 424 could also be pivotally mounted to urge pipe out of pipe tub 400.

[0200] In another embodiment, the tub or rack of pipes may be higher than the surface of catwalk 311 and the catwalk moving elements act as the pipe feed to control the flow of pipe from the pipe tub or rack 400 of pipe. Accordingly, the pipe feed may or may not be mounted within pipe tube 400.

[0201] In yet another embodiment, as shown in FIG. 23C pipe tub 400 may comprise means for moving pipe from the bottom to the top of the pipe tub 400, such as a hydraulic floor or a spring loaded floor. In one embodiment, pipe tub 400 may also contain pipe gate 426 at an upper edge of pipe tub 400 for efficiently moving pipe from pipe tub 400 to pipe feed receptacle 424.

[0202] FIG. 23C is a cross sectional view of another possible embodiment of a pipe feeding mechanism with the pipes present. The embodiment of pipe tub 400 shown in FIG. 23C may also be utilized for receiving pipe as the pipe is removed from the well in conjunction with pipe ejection mechanisms and/or catwalk pipe moving elements discussed hereinbefore. As discussed hereinbefore, pipe tub 400 contains sloped bottom 428 and optional pipe rungs 423 for controlling movement of pipes towards pipe gate 426. The downward sloped angle of pipe rungs 432 and their placement inside pipe tub cavity 420 continually move pipe as pipe gate 426 opens to allow pipe P to be received by pipe feed receptacle 424. Pipe feed receptacle 424 lifts pipe P to an upper position adjacent a surface of catwalk segment 311 for movement unto kickout arm 360. Various types of lifting mechanisms may be utilized for pipe feed receptacle including hydraulic, electric, or the like. Pipe gate 426 controls movement of pipe onto pipe feed

receptacle **424** which is supported by vertical support member **430** and support base **440** to prevent movement during operation.

[0203] FIG. 23D is a cross sectional view of a pipe feeding mechanism with the pipes removed in accord with one possible embodiment of the present invention. Pipe feed mechanism **422** is positioned between pipe tub **400** and catwalk segment **311**. Pipe tub **400** contains pipe gate **426** at a lower end of pipe tub **400** facing catwalk segment **311**. Pipe rungs **432** may be utilized in connection with sloped bottom **428** within pipe tub **400** for controlling the movement of pipe **P** towards pipe gate **426**. As discussed hereinbefore, pipe feed receptacle **424** is stabilized by vertical support member **430** and support base **440** while in this position. Pivotal rungs may be removable or pivotal to open for filling the pipe tub more quickly.

[0204] FIG. 23E is a cross sectional view of a pipe feeding mechanism in accord with one possible embodiment of the present invention. In this embodiment, pipe rungs **432** are omitted so that pipe tub cavity **420** only contains sloped bottom **428** and pipe gate **426**. This arrangement allows a higher volume of pipe to be stored in pipe tub **400** for drilling operations. Sloped bottom **428** will urge pipe towards pipe gate **426** which remotely opens and closes to allow pipe **P** to be received by pipe feed receptacle **424**. After pipe **P** has cleared pipe gate **426**, it will be hoisted along vertical support member **430** via pipe feed receptacle **424** until it reaches catwalk segment **311**. Once at catwalk segment **311**, pipe **P** will be further urged to pipe arm **320** by catwalk moving elements **314** (See FIG. 23B). In one embodiment, the pipe feeding mechanism of FIG. 23E may be utilized with the pipe tub **400** of FIG. 23C. When removing pipe from the well, the pipe may be positioned onto the rungs by catwalk moving elements and/or pipe ejection elements discussed hereinbefore.

[0205] During operation for insertion of pipes into the wellbore, pipes are moved from pipe tubs **400** to the catwalk (if desired by automatic operation) and in one embodiment catwalk pipe moving elements **314** are activated to urge the pipes into pipe grooves **378** past retracted pipe clamps **387A**, **389A** and/or **387B**, **389B**. Once the pipe is in the grooves, then the pipe clamps are pivoted upwardly **387A**, **389A** and/or **387A**, **389A** to clamp the pipes. During this time, the length and other factors of the pipe is sensed or read by RFID tags. Pivotal pipe arm **320** is then rotated upwardly to the desired position (which may be determined by sensors and/or an upper mast fixture **315**). Kickout arm **360** pivots outwardly to orient the pipe vertically.

[0206] Top drive **150** is lowered using drawworks **620** to lower traveling block assembly **153**, and top drive shaft **165** is rotated to threadably connect with the upper pipe connector. The pipe is then lowered utilizing traveling block assembly **153** and top drive **150** so that the lower connection of the pipe is connected to the uppermost connection of the pipe string already in the wellbore and the pipe may be rotated to partially make up the connection. The pipe tongs **170** are moved around the pipe connection to torque the pipe with the desired torque and the torque sensor measures the make-up torque curve to verify the connection is made correctly. The pipe tongs are moved out of the way. The slips are disengaged and the pipe string is lowered so that the pipe upper connection is adjacent the rig floor and the slips are applied again to hold the pipe string. The pipe tongs may be brought back in for breaking the connection of this pipe and may utilize reverse rota-

tion of the top drive to undo the connection. Using drawworks **620** to raise traveling block assembly **153**, top drive **150** is moved back toward the mast top in readiness for the next pipe.

[0207] To remove pipe from the well bore, the top drive is raised so that the lower connection of the pipe for removal is available to be broken by pipe tongs. Once broken, the top drive may be used to undo the connection the remainder of the way. The pipe is then raised, kickout arm **360** is pivoted outwardly, and clamps **370A** and **370B** clamp the pipe. The connection to the top drive is then broken by rotation of the top drive shaft **165**, whereupon the top drive is moved out of the way. Kickout arm **360** is then pivoted back to be adjacent pivotal pipe arm **320**. Pivotal pipe arm **320** is lowered. Clamps **370A** and **370B** are released and retracted. Either the eject arms **374A** or **374B** are activated depending on which side the pipe tube is located. Accordingly, a single operator can run pipe into the well, perform services, and remove pipe from the well. Other personnel at the well site may be utilized for other functions such as cleaning pipe threads, removing thread protectors, moving pipe onto pipe tubs, which may also simply comprise racks, checking mud measurements, checking engines, and the like as is well known.

[0208] For alignment purposes of the present application, a wellhead, BOP, snubber stack, pressure control equipment or other equipment with the well bore going through is considered equivalent because this equipment is aligned with the path of the top drive.

[0209] FIG. 24A depicts a perspective view of an embodiment of a gripping apparatus **1000** engageable with a top drive, such that pipe segments can be gripped by the apparatus **1000** to eliminate the need to thread each individual segment to the top drive itself. FIG. 24B depicts a diagrammatic side view of the apparatus **1000**.

[0210] The apparatus **1000** is shown having an upper connector **1002** (e.g., a threaded connection) usable for engagement with the top drive, though other means of engagement can also be used (e.g., bolts or other fasteners, welding, a force or interference fit). Alternatively, the gripping apparatus **1000** could be formed integrally or otherwise fixedly attached to a top drive or similar drive mechanism.

[0211] The apparatus **1000** is shown having an upper member **1004** engaged to the connector **1002**, and a lower member **1006**, engaged to the upper member **1004** via a plurality of spacing members **1008**. While FIGS. 24A and 24B depict the upper and lower members **1004**, **1006** as generally circular, disc-shaped members, separated by generally elongate spacing members **1008**, it should be understood that the depicted configuration of the body of the apparatus **1000** is an exemplary embodiment, and that any shape and/or dimensions of the described parts can be used. The lower member **1006** is shown having a bore **1010** therein, through which pipe segments can pass.

[0212] During operation, the apparatus **1000** can be threaded and/or otherwise engaged with the top drive, then after positioning of a pipe segment beneath the top drive and apparatus **1000**, e.g., using a pipe handling system, the apparatus **1000** can be lowered by lowering the top drive. An end of the pipe segment thereby passes through the bore **1010**, such that slips or similar gripping members disposed on the lower member **1006** can be actuated (e.g., through use of hydraulic cylinders or similar means) to grip and engage the pipe segment. Continued vertical movement of the top drive along the mast thereby moves the apparatus **1000**, and the pipe segment, due to the engagement of the gripping mem-

bers thereto. Likewise, rotational movement of the top drive (e.g., to make or unmake a threaded connection in a pipe string) causes rotation of the apparatus 1000, and thus, rotation of the gripped pipe segment. The apparatus 1000 is thereby usable as an extension of the top drive, such that pipe segments need not be threaded to the top drive itself, but can instead be efficiently gripped and manipulated using the apparatus 1000.

[0213] Other types of attachments for engagement with a top drive or other drive system, and/or for engaging and/or guiding a tubular joint are also usable. For example, FIG. 25A depicts an exploded perspective view of an embodiment of a guide apparatus 1100 engageable with a top drive such that tubular joints brought into contact with the guide apparatus 1100 can be moved toward a position suitable for engagement with the top drive (e.g., in axial alignment therewith). FIG. 25B depicts a diagrammatic side view of the guide apparatus 1100.

[0214] Specifically, the guide apparatus 1100 is shown having an upper member 1102 that includes a connector (e.g., interior threads) configured to engage a top drive and/or other type of drive mechanism, though other means of engagement can also be used (e.g., bolts or other fasteners, welding, a force or interference fit). Alternatively, the guide apparatus 1100 could be formed integrally or otherwise fixedly attached to a top drive or similar drive mechanism.

[0215] The upper member 1102 is shown engaged to the remainder of the guide apparatus 1100 via insertion through a central body 1106 having an internal bore, such that a threaded lower portion 1104 of the upper member 1102 protrudes beyond the lower end of the central body 1106. A collar-type engagement, shown having two pieces 1108A, 1108B, connected via bolts 1110, nuts 1111, and washers 1113, can be used to secure the upper member 1102 to the remainder of the apparatus 1100, though it should be understood that the depicted configuration is exemplary, and that any manner of removable or non-removable engagement can be used, or that the upper member 1102 could be formed as an integral portion of the guide apparatus 1100.

[0216] A lower member 1112 is shown below the upper member 1102, the lower member 1112 having a generally frustoconical shape with a bore 1114 extending therethrough. The shape of the lower member 1112 defines a sloped and/or angled interior surface 1116. A plurality of spacing members 1118 are shown extending between the lower member 1112 and the central body 1106, thus providing a distance between the lower member 1112 and the upper member 1102 and/or a top drive connected thereto. While FIGS. 25A and 25B depict the upper member 1102 and central body 1106 as generally tubular and/or cylindrical structures, it should be understood that any shape and/or configuration could be used. Similarly, while the lower member 1112 is shown as a generally frustoconical member, other shapes (e.g., pyramid, partially spherical, and/or curved shapes) could be used to present an angled and/or curved surface in the direction of a tubular.

[0217] During operation, the guide apparatus 1100 can be threaded and/or otherwise engaged with the top drive, then after positioning of a tubular joint beneath the top drive and the guide apparatus 1100 (e.g., using a pipe handling system), the guide apparatus 1100 can be lowered by lowering the top drive. After the end of the tubular joint passes through the lower end of the bore 1114, the end of the tubular joint contacts the angled interior surface 1116. Continued move-

ment of the guide apparatus 1100 causes the tubular to move along the angled interior surface 1116 until the end of the tubular exits the upper end of the bore 1114, where contact between the tubular and the upper portion of the lower member 1112, and/or between the tubular and the spacing members 1118 prevents further lateral movement of the tubular relative to the guide apparatus 1100.

[0218] The end of the tubular joint can then be connected (e.g., threaded) to the lower portion 1104 of the upper member 1102. Continued vertical movement of the top drive along the mast thereby moves the guide apparatus 1100, and the tubular joint, due to the engagement between the joint and the guide apparatus 1100. Likewise, rotational movement of the top drive (e.g., to make or unmake a threaded connection in a pipe string) causes rotation of the guide apparatus 1100, and thus, rotation of the engaged tubular joint. The guide apparatus 1100 is thereby usable as an extension of the top drive, such that tubular joints need not be threaded to the top drive itself, where misalignment can occur, but can instead be presented in a misaligned position, contacted against the angled interior surface 1116, and moved into alignment for engagement with the apparatus 1100. In alternate embodiments, the upper member 1102 and lower portion 1104 thereof could be omitted, and a tubular joint could be engaged with a portion of the top drive directly.

[0219] FIG. 26 is a top view of a roller and a support rail in accord with one possible embodiment of the present invention. Roller 158 is one of several rollers connected to both guide frames 152A and 152B (See FIGS. 19 and 19C-C). Roller 158 is connected to guide frame 152 at roller axle 159 allowing roller 158 to spin freely around roller axle 159. Support rail 176 is sized to mate with groove 173 of roller 178 to facilitate movement of top drive 150 along support rail 176. In another embodiment, support rail 176 could contain groove 173 whereby roller 158 is sized to engage groove 173 to facilitate movement of top drive 150. In this way, rollers 158 may be utilized to prevent rotation of the top drive and to reduce back and forth movement as may occur in prior art systems.

[0220] It will be understood that grooves could be provided in the guide frame whereby the rollers fit in the groove of the guide frame rather than the groove being formed in the rollers. The grooves may be of any type including straight line grooves where the groove sides may be angled or perpendicular with respect to the axis of rotation of the rollers. As well, the grooves may be curved. The grooves may also have combination of angled and perpendicular lines or any variation thereof. Mating surfaces in the opposing component, either the guides or the rollers are utilized. There may be some variation in size to reduce friction, e.g., the groove may have a bottom width of two inches and the inserted member may have a maximum width of 1 and three-quarters inches and so forth. As discussed above, the grooves may be V-shaped or partially V-shaped.

[0221] Turning to FIGS. 27A and 27B, a top view of a crown block assembly in accord with one possible embodiment of the present invention. Crown block 190 has cluster of sheaves 193 located on top of mast assembly 100. Sheaves 193A, 193B, 193C, 193D have an axis of rotation X upon which the sheave cluster 193 rotates. Traveling sheave block assembly 153 has sheaves 146A, 146B, 146C, 146D which are fastened to said guide frame 152 of top drive fixture 150 (see FIG. 19). Traveling sheave block assembly 153 has axis of rotation Y, which is offset in relation to axis of rotation X

upon which sheave cluster **193** rotates. In one embodiment, the offset is less than ninety degrees. In another embodiment, the offset is less than forty five degrees. In another embodiment, the offset is less than twenty five degrees. It will be understood that these ranges would also apply if any multiple of ninety degrees were added to these ranges, e.g., between ninety and one-hundred eighty degrees. This orientation improves the ability of sheave cluster **193** and traveling sheave block assembly to reeve a drilling line. When the traveling sheaves move closely to the crown sheaves, the offset aids in providing a smoother transition from one set of sheaves to the other in that sharp bends of the drilling line are avoided.

**[0222]** Generally, sheave wheels have a minimum diameter with respect to the type of drilling line to limit the amount of bending of the drilling line. Generally, the minimum sheave diameter will be between fifteen times and thirty times the diameter of the drilling line. However, this range may vary. Accordingly, in some embodiments, the ratio of sheave wheel diameter to drilling line diameter may be less than twenty.

**[0223]** Turning to FIGS. **28A** and **28B**, one possible embodiment of long lateral completion system **10** is depicted. A well site with first wellhead **12** and second wellhead **14** is shown. As discussed hereinbefore, long lateral completion system **10** can work well with wellheads in close proximity with each other on a well site, which can be less than a 10 foot distance between first wellhead **12** and second wellhead **14**. Pipe arm assembly **300** occupies a rear portion of skid **16** while rig floor **102** is positioned at a front end of skid **16** closest to second wellhead **14**. In another embodiment, rig floor **102** and pipe arm assembly **300** are operable without skid **16**. Skid **16** is positioned so that rig platform **102** is directly above second wellhead **14**. Rig floor **102** may or may not be part of skid **16**.

**[0224]** FIG. **28B** depicts long lateral completion system **10** in accord with one possible embodiment of the present invention. Rig carrier **600** is shown with mast assembly **100** in an upright position. Mast assembly **100** extends past a rear portion of rig carrier **600** so that top drive unit mounted within mast assembly **100** is positioned directly above first wellhead **12** for drilling operations, as discussed hereinbefore. In other embodiments, sensors such as laser sights or guides mounted to the rear of rig carrier **600**, and the like may be utilized, e.g., mounted to and/or guided to the well head, to locate and orient the axis of mast assembly **100** precisely with respect to the wellbore of first wellhead **12**.

**[0225]** Rig floor **102** is shown positioned above second wellhead **14** providing operators access to mast assembly **100** when conducting drilling operations on first wellhead **12**. System **10** is configured so that pivotal pipe arm **320** of pipe handling system **300** can move pipe to and away from mast assembly **100** without contacting rig floor **102** during operation. Pivotal pipe arm **320** uses control arm **315** to pivot about pipe arm pivotal connection **313** creating an angle which avoids rig floor **102**.

**[0226]** In another embodiment of the present invention, pivotal pipe arm **320** may contain kickout arm **360**. In this embodiment, kickout arm **360** remains generally parallel to pivotal pipe arm **30** except when pivotal pipe arm **360** is moved into the upright position shown in FIG. **7**, FIG. **8**, and FIG. **9**. Upon reaching the upright position, kickout arm **360** is pivoted using the hydraulic actuators **362**, which cause kickarm **360** to pivot away from pipe arm **360** about kick arm pivot connection **312** (See FIG. **16B**). This preferred configura-

tion of long lateral completion system **10** allows drilling operations on multiple wells in close proximity, which can be less than 10 feet apart in certain embodiments.

**[0227]** While certain exemplary embodiments have been described in details and shown in the accompanying drawings, it is to be understood that such embodiments are merely illustrative of and not devised without departing from the basic scope thereof, which is determined by the claims that follow. Moreover, it will be appreciated that numerous inventions are disclosed herein which are taught in various embodiments herein and that the inventions may also be utilized within other types of equipment, systems, methods, and machines so that the invention is not intended to be limited to the specifically disclosed embodiments.

What is claimed is:

1. A pipe tong fixture comprising:

A conventional pipe tong apparatus;

A frame;

At least one actuating skid fixedly attached to the frame for allowing movement of the conventional pipe tong apparatus.

2. The pipe tong fixture of claim 1, further comprising: a mast.

3. The pipe tong fixture of claim 1, wherein the frame for allowing movement of the conventional pipe tong apparatus allows movement along a back-and-forth axis.

4. The pipe tong fixture of claim 1, wherein the frame for allowing movement of the conventional pipe tong apparatus allows movement along a substantially vertical axis.

5. The pipe tong fixture of claim 3, wherein the frame for allowing movement of the conventional pipe tong apparatus further allows movement along a substantially vertical axis.

6. The pipe tong fixture of claim 5, wherein the frame for allowing movement of the conventional pipe tong apparatus further allows movement along a lateral axis.

7. The pipe tong fixture of claim 3, further comprising a torque sensor.

8. The pipe tong fixture of claim 5, further comprising a torque sensor.

9. A pipe tong fixture comprising:

A frame, having two substantially parallel arm skids having actuating units capable of providing movement along a back-and-forth axis to a conventional pipe tong fixedly attached to the frame, the two substantially parallel arm skids further comprising a plurality of actuators for providing lateral movement to the conventional pipe tong fixedly attached to the frame;

A mast comprising one or more rails for the frame to travel thereupon, wherein the frame is capable of traveling along a substantially vertical axis.

A torque sensor;

10. The pipe tong fixture of claim 9, wherein the torque sensor is fixedly attached to the conventional pipe tong.

11. The pipe tong fixture of claim 10, wherein the fixedly attached torque sensor is in communication with a control panel attached to a rig carrier.

12. The pipe tong fixture of claim 10, wherein the fixedly attached torque sensor is in communication with a control panel in a remote control-cabin.

13. The pipe tong fixture of claim 10, wherein the fixedly attached torque sensor is in wireless communication with a remote control-center.

14. A process of remotely operating a pipe tong apparatus comprising the steps of:

Establishing a communication connection between a pipe tong apparatus and a remote control-cabin;

Receiving at the pipe tong apparatus a first signal via the communication connection to open the pipe tong apparatus;

Receiving at the pipe tong apparatus a second signal via the communication connection to close the pipe tong apparatus thereby encircling a section of production tubing;

Receiving at the pipe tong apparatus a third signal via the communication connection to apply a torque force to the section of production tubing;

Reading the torque force applied to the section of production tubing to obtain a torque force value; and

Transmitting to the remote control-cabin the torque force value for storage.

**15.** The process of claim **14**, further comprising the additional step of:

Receiving a movement signal at the pipe tong apparatus, the movement signal causing the pipe tong apparatus to vertically travel within a mast.

**16.** The process of claim **14**, further comprising the additional step of:

Receiving a movement signal at the pipe tong apparatus, the movement signal causing the pipe tong apparatus to travel along a back-and-forth axis within a mast.

**17.** The process of claim **14**, further comprising the additional steps of:

Receiving a first movement signal at the pipe tong apparatus, the first movement signal causing the pipe tong apparatus to vertically travel within a mast.

Receiving a second movement signal at the pipe tong apparatus, the second movement signal causing the pipe tong apparatus to travel along a back-and-forth axis within a mast.

**18.** The process of claim **17**, wherein the communication is wired communication connection.

**19.** The process of claim **17**, wherein the communication is a wireless communication connection.

**20.** The process of claim **17**, wherein the mast is situated proximal to a well head.

\* \* \* \* \*