

W. Ballard,

Spark Arrester.

No. 104,099.

Patented June 14, 1870.

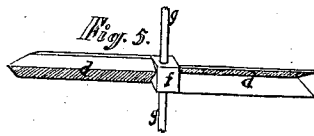
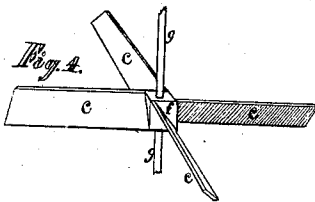
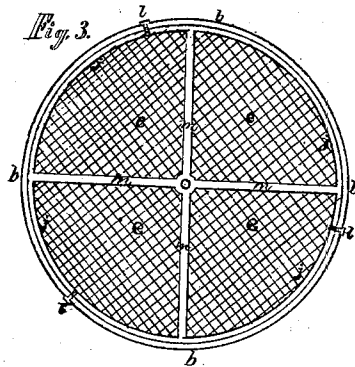
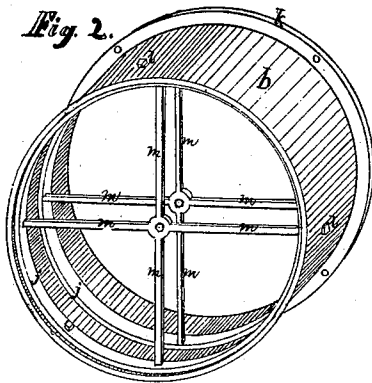
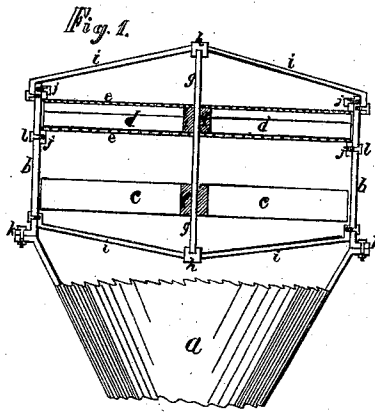

Witnesses,

A. Constack
J. L. Miller

Inventor:

William Ballard

United States Patent Office.

WILLIAM BALLARD, OF CAROLINE, NEW YORK.

Letters Patent No. 104,099, dated June 14, 1870.

SPARK-ARRESTER.

The Schedule referred to in these Letters Patent and making part of the same.

I, WILLIAM BALLARD, of the town of Caroline, in the county of Tompkins and State of New York, have invented certain Improvements in Spark-Extinguisher, of which the following is a specification.

My invention relates to the combination of wind-mills, bars, arms, shafts, sieves, bolts, and stays, in such a manner that the same shall be capable of extinguishing sparks of fire in a chimney or the smoke-stack of an engine, the object of my invention being to prevent the sparks escaping from the chimney or smoke-stack of an engine, as aforesaid.

I will now proceed to describe my invention, so that those skilled in the art may be enabled to make and use the same, reference being had to the accompanying drawing forming a part of this specification, in which—

Figure 1 is a sectional view of my invention placed in the smoke-stack of an engine, the upper part of said smoke-stack being cut away in order to show the same.

Figure 2 is a perspective view of the frame used by me to hold the sieves and grinders in connection with my invention.

Figure 3 is a view of the sieve used by me.

Figure 4 is a perspective view of the wind-mill used by me in connection with my said invention.

Figure 5 is a view of the grinders used by me.

Figure 6 is a view of the end of the fan to the mill.

Figure 7 is a view of the end of the grinder.

Similar letters of reference indicate like parts.

a is the lower part of an ordinary smoke-stack.

b is the upper part of the same.

c are the wings of the wind-mill.

d are the arms of the grinder.

e are the sieves.

f is the hub of the wind-mill and also of the grinder.

g is the shaft upon which both wind-mill and grinder are fastened, and attaches the one to the other.

h are the sockets supporting the shaft aforesaid.

i is the strap or stay to hold the structure in position.

j are the bands to the sieves.

k is the outside flange to the smoke-stack.

l are the bolts which hold the structure up in the smoke-stack.

m are the bars or arms under the lower sieve and over the upper one, rendering them more firm and less liable to sag in the center; it being desirable to maintain as even a surface as possible.

All parts of the structure should be made of metal.

The wind-mill is placed below the lower sieve, and is caused to revolve by the draught of the chimney or smoke-stack, as the case may be.

The grinder is placed between the two sieves *e*, and, being attached to the wind-mill by the shaft *g*, turns as the wind-mill revolves. The lower sieve being quite coarse allows the cinders and sparks to fly through, when they are caught by the arms of the grinder and pressed against the upper sieve, which is finer, and thus extinguished.

I claim the privilege of using my invention in chimneys, smoke-stacks of engines, and all other fire and smoke-flues.

Having thus described my invention,

What I claim as new, and desire to secure by Letters Patent, is—

The combination of the wind-mill *c*, the arms or grinders *d*, the upper and lower sieves *e*, the shaft *g*, the supports *h*, the stays *i*, the bands or supports *j*, the bolts *l*, and the bars *m*, substantially as and for the purpose hereinbefore set forth.

Dated Marathon, February 18, 1870.

WILLIAM BALLARD.

Witnesses:

I. COMSTOCK,
J. L. MILLER.