



INTERNATIONAL APPLICATION PUBLISHED UNDER THE PATENT COOPERATION TREATY (PCT)

<p>(51) International Patent Classification ⁵ : B01J 49/00</p>	<p>A1</p>	<p>(11) International Publication Number: WO 93/00168 (43) International Publication Date: 7 January 1993 (07.01.93)</p>
<p>(21) International Application Number: PCT/US92/05277 (22) International Filing Date: 19 June 1992 (19.06.92) (30) Priority data: 721,180 26 June 1991 (26.06.91) US (71) Applicant: BRUNER CORPORATION [US/US]; 500 West Oklahoma Avenue, Milwaukee, WI 53207 (US). (72) Inventors: TICCIONI, James, E. ; 11811 West Bonniwell Road, Mequon, WI 53092 (US). COLBURN, Robert, W. ; 2964 Sonoran Trail, Green Bay, WI 54313 (US). (74) Agents: O'SHAUGHNESSY, James, P. et al.; Foley & Lardner, First Wisconsin Center, 777 East Wisconsin Avenue, Milwaukee, WI 53202-5367 (US).</p>		<p>(81) Designated States: AU, CA, JP, KR, European patent (AT, BE, CH, DE, DK, ES, FR, GB, GR, IT, LU, MC, NL, SE). Published <i>With international search report.</i></p>

(54) Title: PROGRAMMABLE WATER TREATMENT CONTROLLER FOR PROGRESSIVE FLOW SYSTEMS

(57) Abstract

The electronic Programmable Water Treatment Controller provides an integrated initiator and sequencer for controlling regeneration of water softening and filtering systems. The controller or associated external device(s) initiates the regeneration sequence or, in the alternative, an alarm based on a programmable prediction time, total volume through the water treatment device or combinations of the foregoing. The sequence of regeneration is controlled in response to selected parameters programmable by the user for valve actuation and timing. Multiple water treatment systems may be controlled in alternating, parallel, or progressive control schemes through communication between controllers, attached to each system, which employ the present invention.

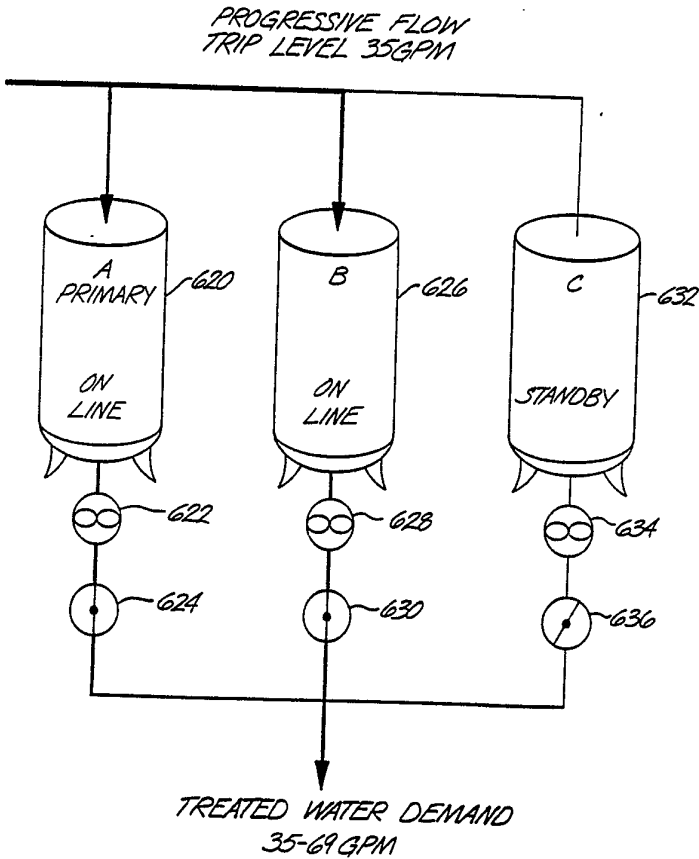

FOR THE PURPOSES OF INFORMATION ONLY

Codes used to identify States party to the PCT on the front pages of pamphlets publishing international applications under the PCT.

AT	Austria	FI	Finland	ML	Mali
AU	Australia	FR	France	MN	Mongolia
BB	Barbados	GA	Gabon	MR	Mauritania
BE	Belgium	GB	United Kingdom	MW	Malawi
BF	Burkina Faso	GN	Guinea	NL	Netherlands
BG	Bulgaria	GR	Greece	NO	Norway
BJ	Benin	HU	Hungary	PL	Poland
BR	Brazil	IE	Ireland	RO	Romania
CA	Canada	IT	Italy	RU	Russian Federation
CF	Central African Republic	JP	Japan	SD	Sudan
CG	Congo	KP	Democratic People's Republic of Korea	SE	Sweden
CH	Switzerland	KR	Republic of Korea	SN	Senegal
CI	Côte d'Ivoire	LI	Liechtenstein	SU	Soviet Union
CM	Cameroon	LK	Sri Lanka	TD	Chad
CS	Czechoslovakia	LU	Luxembourg	TG	Togo
DE	Germany	MC	Monaco	US	United States of America
DK	Denmark	MG	Madagascar		
ES	Spain				

1

5

-1-

10

**PROGRAMMABLE WATER TREATMENT CONTROLLER
FOR PROGRESSIVE FLOW SYSTEMS**

Cross-reference to Related Application

15 This application is a continuation-in-part of
prior U.S. Patent Application Serial No. 07/371,546
filed on June 26, 1989 wherein a system for a new and
superior programmable water treatment controller is
described.

Background of the Invention

20

1. Field of the Invention

The present invention relates generally to
controllers for water softening and filtering
systems. In particular, the invention provides a
controller for initiating an alarm or regeneration
25 sequence based on a programmable prediction time,
total flow through the water treatment device, or
combinations thereof, and controlling the sequence of
regeneration in response to selected parameters for
valve actuation and timing. The invention further
30 provides the capability for integrating multiple
water treatment systems for alternating, parallel or
progressive water flow through each of the respective
systems.

35

2. Prior Art

Water treatment systems for softening or
filtration of hard water typically require

-2-

1 regeneration after the treatment of a quantity of
water. Apparatus and methods for the softening of
water for residential or commercial applications use
are exemplified by U.S. Patent Nos. 3,815,747;
5 3,960,721; 4,298,468; 4,239,621; and 4,421,652.

In typical water softening systems, hard
mineral ions are removed from the water by passing
the hard water through a cation exchange resin.
These resins are typically in granular form and
10 remove the hard mineral ions and replace them with
other cations, typically sodium.

After treatment of a large enough volume of
hard water, the resins become exhausted. The resin
may be regenerated by passing a sodium chloride
15 solution or brine through the resin. Steps to loosen
the resin, typically known as back-washing, and
rinsing of the brine from the resin are additional
steps taken in the regeneration cycle. Multiple
back-washing steps, rinsing steps, and flushing steps
20 may be performed in an optimized cycle to regenerate
the resin.

Control of a prior art regeneration system
was typically accomplished first through the use of
an initiator which monitored time or total flow of
25 hard water through the system and generated a signal
upon reaching a preset limit. The signal from the
initiator was received by a separate sequencer which
mechanically or electrically activated valving to
accomplish the regeneration sequence. A lack of
30 compatibility between initiators and sequencers
produced by different manufacturers has often
prevented consumers from optimizing regeneration of
water softening systems to meet individual needs.
Further, use of multiple water softening units in
35 alternate configurations where one unit produces soft
water while the other unit is in regeneration or on
standby, parallel operation where multiple water

-3-

1 treatment units are operated in parallel, but undergo
regeneration at different times, or progressive
operation where multiple water treatment units are
available and placed on line only as demand requires
5 and individually regenerating when off line, has not
been possible due to lack of a controller capable of
coordination of multiple systems.

10

15

20

25

30

35

1 Summary of the Invention

 The present invention overcomes the shortcomings
in the prior art by integrating an initiator and
sequencer in a single control unit. Further, the
5 invention provides for communication between control
units for coordinated operation of multiple water
treatment systems. The invention provides a
plurality of valve control signal outputs, one of
which controls the service valve allowing treated
10 water to pass through the system. A first status
input receives a valve position signal which allows
comparison of the actual condition of regeneration
valving with the control outputs from the invention.
Rate of flow for water from the water treatment
15 system is received by the invention on a flow rate
input for calculation of current and total flow
through the water treatment system. An input means
is provided for selection of the operational type of
the invention, interrogation of the status or manual
20 control of the operation of the water treatment
system. In the present embodiment, the input means
comprises an input keypad for input of control
parameters for the regeneration sequence as well as
interrogation of the controller status, control
25 parameters, and manual operation of the water
treatment system regeneration. A memory is provided
for storage of control parameters received from the
input means. A display unit is employed for alpha
numeric display of the status during normal
30 operation, an alarm indication during abnormal
operation, and display of mode programming step or
regeneration step responsive to signals from the
input means. An audible alarm, which may be
selectably delayed or silenced, augments the display
35 unit for notification of abnormal conditions.

 A plurality of timing means programmable through
the input means are connected to the valve control

1 signal output means for activation thereof. An
additional timing means programmable through the
input means, and a means for calculating the total
flow selectably initiate a regeneration cycle,
5 thereby initiating the plurality of timers. Means
for communication between two or more controllers,
including means for recognizing a master/slave status
allows simultaneous coordinated operation of two or
more water treatment systems.

10

15

20

25

30

35

1 Description of the Drawings

FIG. 1 is a general block diagram schematic representation of the invention;

5 FIG. 2 is a pictorial representation of the front panel of the invention;

FIG. 3 is an electrical schematic of a first embodiment of the invention;

FIG. 4a is a flow diagram of the operation of the invention;

10 FIG. 4b is a supplemental flow diagram for operation of the invention in multiple water treatment system applications;

FIG. 4c is a supplemental flow diagram for operation of the invention with a statistical prediction technique;

15 FIG. 4d is a supplemental flow diagram for progressive operation of the invention;

FIG. 5 is a flow diagram of the regeneration control sequence of the invention;

20 FIG. 6 is a three tank illustration of parallel flow water treatment system;

FIG. 7 is a three tank illustration of a progressive flow water treatment system with the water demand less than a programmed flow rate;

25 FIG. 8 is a three tank illustration of a progressive flow water treatment system with the water demand above but less than twice the programmed flow rate;

30 FIG. 9 is a three tank illustration of a progressive flow water treatment system with the water demand at or above the programmed flow rate; and,

35 FIG. 10 is a three tank illustration of a progressive flow water treatment system with the water demand at or above the programmed flow rate regeneration mode.

1 Detailed Description of the Invention

 The overall architecture of a present embodiment
of the invention is shown in FIG. 1. The controller
10 has three control signal outputs 12a, 12b and 12c.
5 The configuration shown in FIG. 1 connects each of
the output signals to a valve controller labeled VC1,
VC2 and VC3, respectively. Each of the outputs may
provide a high or low (on or off) signal. Those
skilled in the art will recognize that two of the
10 output lines in combination may be used for operation
of regeneration valve packages requiring multiple
signal inputs such as that described in U.S. Patent
No. 3,797,523. For example, the first output could
provide an enabling signal when high, with the second
15 output providing a strobe when high to clock a
multiple-position valve through various positions.
As an alternative, the first and second outputs
combined could provide a two-bit decodable signal
corresponding to four positions in a multi-position
20 valve controller.

 In the embodiment shown, the third output signal
is connected to valve controller VC3, which controls
position of the service valve on the water treatment
system. The service valve in the open position
25 allows water flow from the treatment system for use
while the service valve in the closed position
precludes use of water from the treatment system.
Typically, the service valve is closed during
regeneration of the water treatment system to prevent
30 the regeneration brine or water employed in backwash
and flush of the system from being drawn into the
user's water system. The service valve may also be
closed when the treatment capability of the system
has been exhausted to prevent drawing of untreated
35 water into the user's system. In multiple-treatment
system applications, the service valve will be closed
when the particular treatment system controlled by

1 the service valve is not on line or in a standby
condition. A status input 14 on the controller
receives a position signal from the service valve.
Typically, the position signal is obtained through a
5 micro-switch engaged by a cam mechanically connected
to the valve. Connection of the cam switch to the
status input allows comparison by the controller of
the commanded service valve position, based on the
actual position of the valve as indicated by the cam
10 switch.

A flow rate input 16 to the controller is
connected to a flowmeter in the present embodiment,
as will be described in greater detail subsequently.
The flowmeter may be one of four types: a hall effect
15 flow transducer, a flow induced sine wave generator,
a flow induced square wave generator, or a dry
contact flow transducer. Calculation of total volume
from the last regeneration and current flow rate is
accomplished by the controller.

20 An input means 18 allows the user to select, set
and monitor the various functions of the invention.
In the present embodiment, the controller is
configured for seven regeneration initiation schemes
and for six regeneration sequence schemes for
25 individual water treatment systems or multiple
systems operating alternately, in parallel or
parallel progressive.

A remote start input 19 allows the start of a
regeneration from an external source through an
30 integral delay reset timer which overrides any
selected regeneration initiation scheme.

As shown in FIG. 2, a portion of the input means
comprises an input keypad having keys grouped by
function into an operation group 210, a display group
212, a program group 214, and a type key 216. The
35 operation of these key groups will be described in
greater detail subsequently. A memory 20 is

-9-

1 connected to the controller to provide storage for
user selected parameters input from the key pad.

5 A display 22 provides readout, in an
alphanumeric format, of various information regarding
status of the controller. During the input of
various control parameters, the display provides
prompts for the necessary input followed by display
of the parameter in the default condition or as input
from the key pad. In the RUN mode, the display
10 provides a readout of the volume remaining for water
which may be treated before exhaustion of the system
alternating with a current flow rate of the treated
stream. If an abnormal condition, as will be
described subsequently, is present, the display will
15 show an alarm condition. During regeneration of the
water treatment system, the display indicates the
particular cycle of regeneration presently active and
time remaining in that cycle.

20 An audible alarm 24 is connected to the
controller for activation in conjunction with an
alarm condition on the display. The audible alarm is
selectably operable immediately upon determination of
an alarm condition or after a user selected time
delay. In the alternative, the alarm may be
25 silenced.

A multiline communications means 26 is provided
for connection of multiple controllers in
applications requiring multiple water treatment
systems. Communications between the controllers
30 allows coordinate^d operation of the water treatment
systems to avoid interfering regeneration sequences
which would deprive the user of treated water.

35 Details of the structure of the present
embodiment are shown in FIG. 3. The primary element
of the controller is a microprocessor 312. AC power
is provided to the controller on inputs 314a and b.
In the present embodiment 24 volt AC power at 47 to

-10-

1 63 Hz provided by a transformer (not shown) from
standard line AC received at the AC inputs is
provided to a power supply circuit 316 for conversion
regulated 24-volt pick off V2, a +5-volt pick off,
5 and an unregulated pick off VUNREG. A first
regulated voltage is provided to the microprocessor
on input 321, and a second regulated voltage is
provided to the microprocessor on input 323. A
10 master clock circuit located provides a real time
clock input 338 for the microprocessor. Those
skilled in the art will recognize alternative power
supply configurations for use in the present
invention.

15 Valve control outputs are provided by the
microprocessor on lines 348, 350 and 352. Output
buffers 354 convert the output signal of the
microprocessor to a 24-volt signal off pick off V2
for operation of the valve controllers.

20 Inputs to the microprocessor are received
through input buffers 362. Input signals to the
controller are asserted by drawing down the
respective input line as designated by signals FLOW
BAR and CAM BAR for the flow input and valve position
input respectively. In the embodiment shown, an
25 additional input 372 is provided as a supplementary
system status signal. As an example, an external
alarm designating a condition such as low brine level
in the water treatment system represented by ALARM
BAR IN for evaluation by the microprocessor in
30 overall system control.

35 In the present embodiment the keyboard portion
of the input means employs a matrix decoding scheme
from four strap outputs 374, 376, 375, and 377 from
the microprocessor to four return inputs 378, 380,
382 and 384 to the microprocessor. The individual
keys on the keyboard 386a through 386h releasably
connect strap outputs 388 and 390 to the four return

-11-

1 inputs 378, 380, 382 and 384. The signals resulting
from keystrokes are maintained by capacitors 392 for
a read cycle time on returns and are bled to ground
through resistors 394.

5 As shown in FIG. 2 the key pad is arranged to
group keys with similar functions. The program key
group includes an enter/exit key 218 which toggles
the controller between the two operating modes RUN or
PROGRAM. In the PROGRAM mode a prompt is momentarily
10 visible on the display followed by a numeric display
with at least one digit flashing or a flashing word
display. The flashing word or digit is altered using
the set digit key 220. Selection of the next digit
for alteration is accomplished by depressing the
15 select digit key 222. If the prompt was not seen,
the current function key 224 may be depressed to
momentarily recall the prompt to the display.
Selection of the next programming step is
accomplished by depressing the next function 226
20 which then causes a momentary display of the prompt
for the next programming step followed by the
flashing word or numerical value with flashing
digits.

25 With the controller in the RUN mode, depressing
the START/STEP key 228 will initiate a regeneration
sequence. In addition, an external dry contact
closure applied to the remote start input 19 will
initiate an adjustable reset off delay timer.
Closures exceeding the delay time will also start a
30 regeneration sequence. Closures shorter than the
delay time will reset the delay timer. Steps in the
regeneration sequence to be described in greater
detail subsequently may be terminated prior to
programmed completion by depressing the START/STEP
35 key. The START/STEP key must remain depressed for
three seconds to initiate or step through the
regeneration sequence. The second key in the

-12-

1 operation group is the AUTO/SEMI-AUTO and ALARM
SILENCE key 230. Depressing this key for three
seconds toggles the controller between AUTOMATIC mode
5 in which the controller initiates and accomplishes
regeneration automatically, or SEMI-AUTOMATIC mode in
which the controller calculates all functions of RUN
sequence but generates an alarm condition notifying
the operator of the requirement for regeneration as
10 opposed to automatically initiating regeneration.
The regeneration sequence is then accomplished
manually by depressing the START/STEP key. Key 230
also allows silencing of the audible alarm when
activated by momentarily depressing the key. The
15 extended depression time required in the operation
group keys avoids inadvertent initiation of a
regeneration sequence or toggling of the controller
into the SEMI-AUTOMATIC mode.

Continuing the description of details in the
embodiment shown in FIG. 3, the communications means
20 between controllers comprises two wire RS485
interface in the embodiment shown in the drawings.
Those skilled in the art will recognize that
communications may be accomplished using other
standard techniques such as a four-wire serial
25 interface having a ground connection, a buffered
serial clock, a serial output, and a buffered serial
input. The remote start input of FIG. 1 is also
provided through an input buffer to the
microprocessor.

30 In an alarm condition as will be described
subsequently, the microprocessor provides an output
through resistor 396 to bias transistor Q3 to
activate an alarm horn, 397. As previously
described, the microprocessor may be programmed to
35 inhibit activation of the alarm horn.

In the present embodiment of the invention the
alphanumeric display 22 is a 16 segment vacuum

1 fluorescent display providing 8 digits with alpha and
numeric capability. The microprocessor communicates
with the display through a plurality of control lines
398a for digit selection and a second plurality of
5 control lines 398b for segment activation.
Alternative display techniques may be employed.

The microprocessor in the preferred embodiment
provides a plurality of timers keyed to the master
clock for cycle timing during the regeneration
10 sequence. Six timers are employed to provide three
alternating cycle times for output A and output B
respectively. One or more additional initiation
timers are employed in several capacities to initiate
the regeneration sequence. Selection of the
15 regeneration sequence may be based on a specific
timed cycle such as a specific time in each selected
period (1 minute to 99 days), a specific time on a
specific day in each weekly period and so on,
depending on size and flow rate in the water
20 treatment system being controlled.

As previously described, the microprocessor
receives flow rate information for calculation of
current flow rate and total flow. A preset total
flow value may be employed to initiate the
25 regeneration sequence and the initiation timer may be
employed to delay initiation of regeneration for a
predetermined period of time after reaching the
preset total flow condition.

In the present embodiment, implementation of the
30 timers and flow calculation is accomplished through
software control of registers in the microprocessor
or equivalent virtual registers in the memory.
Operation of the microprocessor in controlling the
various functions previously described is best
35 understood with reference to FIG. 4. Programming of
the individual attributes in the operation of the
system will be described subsequently.

-14-

1 Upon power up the controller is reset as
previously described and enters the run mode at box
410. The microprocessor polls the CAM input to
determine the service valve position. This is
5 designated a phase comparison as shown in box 412.
If the CAM signal indicates the service valve is
closed, output C will energize, thus commanding the
service valve to close and a visual alarm will be
energized as shown in block 413. Outputs A and B
10 will simultaneously energize to correct the out of
phase condition until the CAM input is satisfied or
a 15 minute period of time has lapsed as shown in
block 414, after which an audible alarm will be
generated as shown in box 415. The microprocessor
15 polls the input means to determine if a multiple
water treatment system is present as shown in box
416. Multiple system operation will be discussed
subsequently. If the input means indicates a single
treatment system, the microprocessor next polls the
20 input means for depression of the START key as shown
in box 418. As previously described, depression of
the START key initiates a regeneration sequence. If
the START key has not been depressed, the
microprocessor reads the flow rate on input 16 as
25 shown in box 420. The microprocessor updates the
total flow since reset as shown in box 422 in the
present embodiment the microprocessor outputs to the
display the flow rate at 10 second intervals,
alternating with the treatable water volume remaining
30 based on a preset capacity of the treatment system
less the total volume treated. The microprocessor
then determines if the preset total volume indicating
exhaustion of the treatment system has been reached
as shown in box 424. If total volume has been
reached, the microprocessor determines if
35 regeneration is to be commanded based on total volume
or a preset time as shown in box 426. If

-15-

1 regeneration is based on total volume, the
microprocessor then determines if a time delay after
reaching total volume has been imposed as shown in
box 428. If a time delay has been specified by the
5 user, the microprocessor then sets the delay value in
the initiation timer as shown in box 430. The
microprocessor then reads the master clock as shown
in box 432 and updates (decrements) the initiation
timer as shown in box 434.

10 If regeneration is to be initiated on a timed
basis as opposed to total volume, the microprocessor
would pass directly from block 424 to block 432 and
a preset value would exist in the initiation timer
which would be decremented on the master clock cycle
15 by the microprocessor. Based on the initiation timer
as shown in block 436, the microprocessor will
continue flow monitoring and time update or begin the
regeneration sequence. If timing is in process on a
time delay as shown in block 438, the microprocessor
20 will cycle the clock until time out.

After the microprocessor determines that
regeneration is required by total volume with or
without time delay or timed initiation, the
microprocessor will determine if the SEMIAUTO switch
25 has been depressed as shown in block 440. If the
switch has been depressed placing the system in
semiauto mode, the microprocessor will generate an
alarm as shown in block 442. The microprocessor will
then monitor for depression of the START key as shown
30 in block 444. If the system is not in the
semiautomatic mode, the microprocessor will poll the
communications means to determine if the multiple
tank interlock (MTI) is set as shown in block 446
which will be described in greater detail
35 subsequently. If the MTI is not set, a regeneration
will be initiated as shown in block 448.

-16-

1 The regeneration sequence is shown in FIG. 5.
Once a regeneration has been initiated, the
microprocessor will set the MTI as shown in block
510. In the embodiment shown in FIG. 5, a counter,
5 i, is set to one as shown in block 512. The
microprocessor then sets the six timers of the
present embodiment to the preset values selected by
the user as shown in block 514. The service valve is
then closed by energizing output C as shown in block
10 516. Output A is then energized as shown in block
522. The first timer is decremented by the
microprocessor as shown in block 524. The
microprocessor continues to decrement the first timer
in response to the master clock as indicated by block
15 526 until the timer has expired. Output A is then
deenergized as shown in block 528 and output B is
energized as shown in block 530. The second timer
is then decremented and monitored as shown in blocks
20 532 and 534 until the second timer has expired at
which time output B is deenergized as shown in block
536. If counter i does not equal 5, as shown in
block 538, the counter is incremented by 2 as shown
in block 540, and blocks 522 through 536 are repeated
for timers 3 and 4 and again for timers 5 and 6.

25 Those skilled in the art will recognize that the
quantity of timers and valve control outputs may be
modified to accommodate any desired configuration.

 Upon completion of the regeneration cycle as
determined by the six timers, the microprocessor
30 verifies via the CAM input that the valve control has
returned to "home" position thus assuring the
electromechanical and electronic element are in phase
as shown in block 518. If the valve control fails to
"home", a visual alarm is generated as shown in block
35 519. Outputs A and B will energize simultaneously
for 15 minutes to force the valve control home
thereby attempting to correct the phase as shown in

1 block 520. Failure to reach home in that time will
result in an audible alarm condition as shown in
block 521. The microprocessor then deenergizes
output C as shown in block 542, reopening the service
5 valve to reenter service as shown in block 544.
Those skilled in the art will recognize that
additional logic may be required prior to
deenergizing output C in block 542 if a multiple
system, as will be described subsequently, is
10 present.

When employed in a multiple treatment system
configuration, operation of the microprocessor is
shown in FIG. 4b. If polling of the input means in
block 416 indicates a multiple treatment system, the
15 microprocessor polls the input means to determine a
status as master or slave as shown in block 450. If
the controller is in a master configuration, the
microprocessor continues at entry point B in FIG. 4a.
If the status of the controller is that of a slave,
20 the microprocessor determines the program type as
alternate or parallel operation as shown in block
452. If the water treatment systems are operating in
parallel, the microprocessor determines if the
program type is parallel progressive as shown in
25 block 453. If the water treatment systems are
operating in parallel, the microprocessor continues
operation at entry point B in FIG. 4a. If the water
treatment systems are operating in parallel
progressive, the system operates as shown in FIG. 4d
30 which will be described subsequently.

If the systems are operating in an alternate
configuration, the microprocessor on the master
device polls the communication means to determine if
the slave controller is in the flow mode as shown in
35 block 454. The master controller determines the
status and then notifies the slave controller. If
the master is flowing, the slave controller remains

-18-

1 in the standby condition as shown in block 456. If
the master is not flowing, the microprocessor on the
slave will open the service valve as shown in block
458, verify phase of the valve as shown in block 460
5 issuing an alarm if phase is improper as shown in
block 462, and enter operation at entry point B of
FIG. 4a.

Those skilled in the art will recognize that
position of the service valve by the controllers of
10 a multiple water treatment system configuration will
be determined by the master/slave status at the entry
point in block 410 of FIG. 4a. Similarly, a slave
controller operating in the standby mode of block 456
will continue monitoring for START key depression for
15 manual regeneration initiation.

In a multiple treatment system configuration,
after updating total volume as shown in block 422,
the microprocessor will poll for multiple system
configuration as shown in block 464 at exit point C
20 of FIG. 4a. If a multiple system is not present, the
microprocessor continues operation at entry point D
in FIG. 4a. If a multiple system is present, the
microprocessor again determines master or slave
status as shown in block 466 and if not a master
25 reenters at point D of FIG. 4a. If the micro
controller is a master, total remaining volume is
calculated as shown in block 468 and a determination
of time remaining to regeneration at the present flow
rate compared to a regeneration time is made as shown
30 in block 470. This determination avoids depletion of
several systems simultaneously thereby staggering
regeneration and avoiding the requirement for
simultaneous regeneration. If sufficient flow volume
remains to continue operation, the microprocessor
35 reenters at entry point D in FIG. 4a. If
insufficient time remains, the master microprocessor
will poll the communication means to determine if the

-19-

1 slave microprocessor is currently undergoing
regeneration. If regeneration of the slave is in
process, the slave will return on line prior to
exhaustion of the master and the master
5 microprocessor reenters at entry point D of FIG. 4a.
If the slave is not undergoing regeneration, the
master will initiate a regeneration sequence in the
controller with the least available "on line" time
remaining at entry point E of FIG. 4a.

10 As an alternative to user preset volumes or
times for regeneration initiation, the microprocessor
may operate as shown in FIG. 4c. Flow data obtained
in block 422 may be employed to update a statistical
data base as shown in block 474 for monitoring of
15 water usage on a volume and time basis. Regeneration
may then be based on a mathematically calculated
prediction factor for exhaustion of the system as
demonstrated in block 476. A volume initiation
override timer is employed supplementally to start a
20 regeneration even if the preset volume has not been
reached as shown in block 478. Such a minimum time
period may be established, for example, as a 24 hour
block. In the alternative or in addition, a maximum
time between regenerations may be established and
25 regeneration initiated based on that maximum time as
shown in block 480. Continued monitoring of the
initiation timer or initiation of the regeneration
sequence is then accomplished by transitioning to
blocks 428 or 432, respectively.

30 Operation of the system in a progressive flow
mode is shown in FIG. 4d. If the determination that
the system is operating in progressive mode is made
in block 453 of FIG. 4b, the units are ranked in
order of time remaining before regeneration is
35 required as shown in block 481 of FIG. 4d. If any
unit is regenerating or phasing before or after
regeneration, as determined in block 482, the other

1 units of the system remain on line as shown in block
487 and the system reenters at entry point B of FIG.
4a. If no unit is regenerating or phasing, a
determination is made as to which unit has the
5 greatest remaining time as shown in block 483. If
the time remaining on unit number 2 is less than the
time remaining on unit number 1, a regeneration of
unit number 1 is initiated as shown in block 486 and
the other unit(s) are brought on line as previously
10 described, in block 487.

If the time remaining on unit number 2 exceeds
time remaining on unit number 1 in the block 483
test, determination of the presence of three units is
made as shown in block 484. If three units are
15 present, a determination is made in block 485 whether
the time remaining prior to required regeneration on
unit number 3 exceeds the combined remaining time on
unit numbers 1 and 2. If not, a regeneration of unit
number 1 is initiated.

20 If three units are not present in the test of
block 484 or if the unit number 3 time remaining is
satisfactory in block 485, a determination is made
whether the flow exceeds the trip level as shown in
block 488. A detailed description of the trip level
25 is provided subsequently. If the flow does not
exceed the trip level, the primary unit only remains
on line as shown in block 489. The service valve of
the unit on line is made as shown is energized as
shown in block 459 of FIG. 4b and verification of the
30 phase of the valve is made in block 461, and with
proper phase the system reenters at entry point B of
FIG. 4a. If the valve phase is not correct the alarm
sequence of blocks 413 through 415 is accomplished
beginning at entry point F of FIG. 4b as previously
35 described.

If the flow is greater than the trip level in
the test of block 488 a determination of the number

1 of units is made in block 490. If only two units are
present, both units are brought on line in block 491
with the system reentering at entry point I of FIG.
4b for phase verification and further processing as
5 previously described.

If three units are present in the test of block
490, a determination if the flow exceeds twice the
trip level is made in block 492. If not, the primary
and first secondary units are brought on line only as
10 shown in block 493 and system processing continues
and entry point I as previously described. If the
flow does exceed twice the trip level value in block
492 all three units are brought on line as shown in
block 494 and system processing again continues at
15 entry point I.

Returning to FIG. 4a, the remote start input
described with respect to FIG. 2 is implemented for
each unit through a normally open dry contact switch
495. Sensing of the switch is accomplished as shown
20 in block 496 and if closure of the switch is detected
a determination is made if the switch remains
depressed sufficiently long to overcome the delay
timer in block 497. If sufficient, a regeneration is
initiated at block 446 as previously defined. If the
25 switch was depressed for an insufficient time, the
delay timer is reset in block 498.

By way of diagrammatical illustration FIG. 6
represents prior technology for operating multiple
treatment systems, while FIGS. 7-10 represent
30 applicant's novel method for operating multiple
treatment systems. FIG. 6 illustrates a triple
treatment system 600 utilizing a parallel flow
pattern. All three tanks 602, 604 and 606 are on-
line thus providing treated water simultaneously.
35 Flow sensors 608, 610 and 612 monitor the water flow
from each of the systems. In a parallel

-22-

1 configuration the outlet valves 614, 616 and 618 are
all in the open position.

5 The greatest advantage of parallel configured
water treatment systems is to provide high flow rates
at low pressure loss. Conversely, at low flow rates
there are several operational problems being poor
water quality and inaccuracy of flow sensing devices.

10 A new feature called progressive flow can be
implemented to maintain the minimum number of tanks
on-line to assure good water quality and meter
accuracy. Progressive flow can be utilized in either
twin or triple water treatment systems. The
progressive flow configuration can be utilized in
program types 23/25 and 24/25/26 of which will be
more fully discussed subsequently.

15 In these program types a flow rate value called
a trip level is incorporated to activate the
progressive flow feature. Only one trip level valve
is required for either a twin or triple water
treatment system. The selection of the trip level is
20 based upon two factors being the resin volume of the
largest softener in the system and pipe size of the
installed water meters. A combination of these two
factors is used to obtain a minimum trip level, while
25 just the resin volume is considered to select the
maximum trip level valve.

The valve selected has a significant effect on
how the system will operate. A minimum trip level
valve will allow the greatest number of tanks on-line
30 with relatively low flows. This will provide low
pressure loss and excellent water quality.
Conversely, a maximum trip level valve will limit the
number of on-line tanks at relatively high flows.
The advantage of this type of operation will be the
35 more even spacing of regenerations. This prevents
the controller from having to prematurely force
regenerations to maintain spacing.

1 FIG. 7 illustrates triple water treatment system
utilizing the progressive flow method. In this
system the trip level valve has been chosen to be 35
gallons per minute, and has been programmed into the
5 controller. When the treated water demand is less
than the trip level valve only water treatment system
620 is on-line providing treated water. Flow sensor
622 monitors the water flow and outlet valve 624 is
open. System 620 is the primary system while systems
10 626 and 632 are standby and outlet valves 630 and 636
respectively maintain the standby status.

 FIG. 8 illustrates the same system however the
treated water demand has exceeded the trip level
valve. Once the treated water demand exceeds the
15 trip level valve outlet valve 630 is opened and
system 626 is placed on-line joining system 620 in
providing treated water. Flow sensor 628 is now
monitoring the flow also. System 632 remains in the
standby position.

20 In FIG. 9 the treated water demand has exceeded
twice the trip level valve. When this condition
occurs outlet valve 636 is opened placing system 632
on-line and in service joining system 620 and 626.
These systems continue to operate in parallel while
25 the demand for treated water remains above twice the
trip level.

 FIG. 10 illustrates the regeneration process for
the progressive flow configuration. When the treated
water supply of system 620 has been exhausted flow
30 sensor 622 will trigger the controller to close
outlet valve 624 taking system 620 off-line and begin
the regeneration process. System 626 then becomes
the primary system and along with system 632 continue
to operate while the demand for treated water remains
35 above the trip level valve. Once regeneration has
been completed, system 620 will return on-line if the
treated water demand is greater than twice the trip

-24-

1 level valve. If the treated water valve is less than
twice the trip level valve, system 620 will remain in
the standby position.

5 When the treated water supply of system 626 has
been exhausted flow sensor 628 will signal the
controller and outlet valve 630 will be closed.
System 632 will become the primary system and will
provide treated water along with system 620 when the
demand exceeds the trip level valve. Systems 620,
10 626 and 632 will rotate as being the primary as the
demand for treated water and the regeneration of the
systems dictate. The primary flow unit rotates in
sequence following a regeneration.

15 It should be noted that arbitrary trip levels
set between the recommended minimum and maximum
values can be used to cause one tank of either a
parallel twin or parallel triple configuration to be
held off line as a standby. Only during periods of
unusually high flow will the standby tank share the
20 flow load. For example a trip level of 185 GPM may
be employed for systems having a treated water demand
of 185 to 369 GPM.

The system operates identically for a twin
system configuration. To deactivate the progressive
25 flow mode of operation while in programs 20-26, the
operator need only key in 000 into the electronic
controller.

As previously described, a memory is associated
with the microprocessor for storage of the control
30 parameters and interim calculations within the
microprocessor for the various control functions. A
present embodiment of the invention employs a
combination of volatile and non-volatile memory and
provides three power failure memory retention means.
35 A first capacitive means retains sufficient voltage
for total memory integrity (data retention) for short
periods of power failure. A battery backup system

-25-

1 may be employed to further extend memory integrity
beyond the decay time of the capacitive protection
means for continued data processing. In the present
embodiment, failure of the 24 volt AC power input
5 inhibits the output control means for the
regeneration sequence valves and service valves.
While this feature conserves power to allow maximum
memory retention and microprocessor function,
initiation of a regeneration sequence is not
10 possible. Consequently, upon power failure, an alarm
condition is generated by the microprocessor
notifying the user that regeneration was not possible
if the initiation sequence has been reached during a
power failure.

15 The non-volatile portion of the memory provides
configuration and program type retention for restart
after power failure.

In addition to the alarm indications for power
failure, phase inconsistency and inhibited
20 regeneration START based on placement of the
controller in the SEMIAUTO mode, an alarm condition
is asserted by the microprocessor in response to the
communication means if improper connection of the
communication means between controllers is present.
25 In multiple tank applications, the microprocessor
polls the communication means including the serial
output and serial input, for communication with the
other controllers. If no communication signals are
present, the alarm is asserted.

30 In the present embodiment as described above,
the invention executes 17 program types within 8
basic program options. The programs are located on
a memory chip located within the electronic program
module in the microprocessor. Each program type has
35 a code number and operates the system by being
selected by the user through programming steps at the
controller through a series of prompts requesting the

1 program desired, the phase and the type. The first
program type, designated type 00, a single water
treatment system is regenerated a maximum of once per
24 hour period based on treated water used. The
5 regeneration schedule is determined automatically by
the controller through the use of a mathematical
formula which calculates a prediction factor as
previously described with respect to FIG. 4c. The
factor is affected by water usage patterns of both a
10 daily and weekly nature. Also included is a calendar
override feature which allows the user to force
regenerations to occur on a fixed time interval basis
should an extended length of time occur between water
usage periods. This prevents organic contamination
15 buildup in the media of the treatment device. The
fixed calendar override interval is programmable from
one to 99 days. The regeneration sequence may be
delayed to a user set time. The unit returns to
service immediately following regeneration.

20 Program types 01 and 02 are the same as type 00
except that the system will operate with two water
treatment systems, one of which will be on line while
the other is regenerated and standing by. Only one
system will regenerate each 24 hour period as
25 determined by the controller. The pair will
alternate as each is calculated to be exhausted.
Simultaneous regeneration is prevented by the
multiple tank interlock as previously described.

30 Program type 10 is unlike any of the other
programs because it is not used with conventional
water softening equipment. Its primary purpose is to
provide the user with an alarm based on the amount of
water treated by a device and the length of time the
treatment device has been in service.

35 Two audible, visual and electrical signal user
setpoints are available for both time and volume
conditions. An audible alarm silence feature permits

-27-

1 the user to cancel the tone but not the continuous
electrical output signal or intermittent visual
display for all setpoints. Two separate sets of
5 continuous electrical signals are available for each
alarm point. One could be used to reduce flow while
the other could be used to totally stop flow.

The user can set the display to show the
remaining volume of treated water available to each
of the two volume alarm setpoints, or to the number
10 of days remaining to each of the two alarm setpoints.
The time duration can be set from 1 to 999 days and
the volume can be from 1 unit (gallon, litre, etc.)
to 9.9 million units.

The user can cancel the time and volume batch at
15 any time, which automatically resets all alarms to
off, and the volumes and times back to their user set
valves.

Program type 20 is employed for a single water
treatment system regenerating based on a user set
20 volume or total volume. The only limiting factor on
the number of regenerations is the speed at which the
brine system of the water treatment system can
produce brine. In most cases the treatment system
should be sized to allow brine makeup. Regeneration
25 will be initiated immediately upon reaching the user
set volume. The system returns to service
immediately upon regeneration. Program types 21 and
22 are the same as type 20 except the system operates
with two water treatment systems, one of which is on
30 line while the other is regenerated and standing by.
Each tank may regenerate independently as the user
set volume of each tank is reached. Simultaneous
regeneration is not possible based on setting of the
MTI as previously described.

35 Program type 23 and 25 are the same as type 20
except the system will operate two water treatment
systems, both of which are on line simultaneously

1 (parallel) or operate in the parallel progressive
mode as shown in FIG. 4b block 453. As each tank's
user set volume is treated, it will be taken off line
immediately, regenerated and placed back on line
5 immediately. However, to preclude the possibility of
one system reaching exhaustion during the
regeneration of the second system, premature
regeneration of the tank having the least volume
remaining will occur if the tank having greater
10 volume remaining is not capable of providing treated
water for the duration of a regeneration as
previously described with respect to FIG. 4b, blocks
470 and 472.

Program type 24 and 25 and 26 are the same as
15 type 20 except the system will operate three water
treatment systems, all of which are on line
simultaneously (parallel) or operate in the parallel
progressive mode as shown in FIG. 4b block 453. As
each tank's user set volume is treated, it will be
20 taken off line immediately, regenerated and placed
back on line immediately. However, to preclude the
possibility of one system reaching exhaustion during
the regeneration of the other systems, premature
regeneration of the tanks having the least volume
25 remaining will occur if the tanks having greater
volume remaining are not capable of providing treated
water for the duration of the regeneration as
previously described.

Program type 30 employs a single water treatment
30 system regenerating a maximum of once per 24 hour
period based on a user set volume of treated water
with the regeneration sequence delayed to a user set
time. The unit returns to service immediately
following regeneration.

35 Program type 31 and 32 operate similarly to type
30 except the system will operate with two water
treatment systems, one of which is on line while the

-29-

1 other is regenerated and standing by. Only one tank
will regenerate in each 24 hour period as needed.
The user set regeneration start time can be different
for each system. The pair will alternate as each
5 system is regenerated. Simultaneous regenerations
are not possible.

Program type 40 employs a single water treatment
system regenerating on the basis of equal 24-hour
time intervals set by the user. Regeneration is
10 initiated at the user set time with the unit
returning to service immediately following
regeneration.

Program type 41 and 42 are identical to type 40
except that two water treatment systems are employed,
15 one of which is on line while the other is
regenerated and standing by. Only one system
regenerates in each user set interval. The pair
alternates as each interval begins and simultaneous
regeneration is not possible.

Program type 50 employs a single water treatment
system regenerating on a day or days of the week
schedule set by the user. The regeneration sequence
initiates at the user set time. The unit returns to
service immediately following regeneration.

Program types 51 and 52 are identical to type 50
with two water treatment systems operating on an
alternate basis. Only one of the two media tanks
will regenerate on the user selected day(s) and the
pair will alternate as each regeneration occurs.
25 Simultaneous regeneration is not possible.

Those skilled in the art will recognize that the
program types defined are example typical of
regeneration control sequences which may be achieved
using the present invention.

35 Programming of user selected times and volumes
as well as regeneration cycle times and sequence are
similar for all program types. "Programming

-30-

1 required-type 30". If the numerical value is present
on the display, the unit is in the run mode.
Transition to the program mode is accomplished by
depressing the ENTER/EXIT key. Depressing the TYPE
5 key results in a display of the controller type
designated by the program selected. Type 30 should
appear. The display should show one of the following
"phase", a numeric value, or "enter time" followed by
a flashing display segment. "Phase" is an alarm
10 condition indicating the valve operator on the
service valve is not properly synchronized as
previously described. Operator action to correct the
unsynchronized condition is required. If the numeric
value appears as previously described, the controller
15 is in the run mode and the ENTER/EXIT key must be
depressed. If the "enter time" display is present,
the controller is in the program mode and programming
may begin. If the controller previously was
displaying the "phase" alarm condition after
20 correction of the condition, the CURRENT FUNCTION key
may be depressed to obtain the "enter time" prompt.
Upon obtaining the flashing display segment
presentation, the SELECT DIGIT key is depressed to
alter the selected (flashing) segment while the SET
25 DIGIT key is employed to alter the value. For
example, in the enter time display a day, hour,
minute and am/pm segments will appear on the display
with one flashing. The SET DIGIT key is employed to
alter the flashing segment while the SELECT DIGIT key
30 alters the flashing segment between the day, hour,
minute and am/pm designation. Upon completion of the
time entry, the NEXT FUNCTION key is depressed and
the display will prompt "enter START time". The
display will then show digits denoting the hour of
35 day, minute of hour, and am or pm. The SET DIGIT and
SELECT DIGIT keys are employed as previously

-31-

1 described to enter the desired START time for the
regeneration sequence.

The user then depresses the NEXT FUNCTION key,
resulting in a prompt "enter alarm time". The set
5 digit and select digit keys are employed to enter a
desired alarm time. The next function key is again
depressed resulting in a prompt "enter alarm mode"
followed by a flashing word "silent". The SET DIGIT
key may be then used to select one of three options,
10 silent, instant, or delayed. The NEXT FUNCTION key
is again depressed resulting in a prompt "enter
desired volume". The SELECT DIGIT and SET DIGIT keys
are employed to enter the desired volume. The NEXT
FUNCTION key is again depressed resulting in a prompt
15 "enter cycle time". The display indicates "CYCL1"
with two digits flashing. The SET DIGIT key is
employed to set the number of minutes desired in the
cycle 1 timer. Each of the six cycle timers is then
set employing the NEXT FUNCTION key as described.
20 Cycle timers which are not employed in the desired
regeneration sequence have a zero time entered.

Upon completion of entry of the cycle times, the
NEXT FUNCTION key is again depressed, resulting in a
prompt "enter meter factor". The SET DIGIT and
25 SELECT DIGIT keys are employed to enter a meter
factor to properly calibrate the flow meter input at
FLOW for the volume per count. As previously
described, a Hall effect, flow induced square wave
generator, or dry contact flow meter may be employed.
30 Upon depressing the next function key, a prompt
"DONE" will appear. The system will automatically
leave the PROGRAM mode and begin the RUN mode.

The invention as previously described may be
employed to control various water treatment systems
35 with different regeneration requirements.

After programming of the system for the desired
program type, the microprocessor monitors flow and

1 time as previously described. The user may initiate
a regeneration sequence at any time by depressing the
START/STEP key as previously described. In addition,
the volume and initiation timer may be reset to the
5 initial programmed values by simultaneously
depressing the SET DIGIT and SELECT DIGIT keys. A
regeneration sequence operation may be verified by
stepping through a regeneration sequence manually
depressing the START/STEP key to initiate each step.

10 The present invention provides a highly flexible
water treatment system controller for single or
multiple water treatment systems. The invention
combines the initiator and sequencer functions of the
prior art employing sophisticated calculation means
15 for sequence initiation based on user programmable
input or statistically derived mathematical
prediction. Sequence control is achieved with
multiple cycle timers activating a plurality of valve
control outputs.

20 Having now described the invention in detail as
required by the patent statutes, those skilled in the
art will recognize modifications to the embodiments
disclosed, both as previously suggested and as
otherwise required for specific implementations.
25 Such modifications fall within the scope and intent
of the invention as defined in the following claims.

Program type 60 employs a single water treatment
system regenerated after a user set number of 1
minute intervals has occurred with a minimum number
30 of 1 minute intervals being 1 minute and a maximum of
9,999 minutes. The regeneration sequence is
initiated immediately after the time interval. The
system goes back on-line immediately following the
regeneration.

35 Programs types 61 and 62 are identical to type
60 except that the system will operate with two water
treatment systems, one of which will be on-line while

-33-

1 the other is regenerated and placed in standby. Only
one system will regenerate immediately after each
user set interval. The pair will alternate as each
new interval period begins. Simultaneous
5 regenerations are not possible.

Program type 70 employs a single water treatment
system with the regeneration sequence initiated by an
external signalling device (hardness monitor,
external push buttons, batching devices, differential
10 pressure switch, turbidimeter etc.). A user set time
delay interval (minimum 3 seconds, maximum 999
minutes) can be programmed to delay a regeneration
sequence from starting until a continuous external
signal of a desired length occurs. External signals
15 of a shorter than desired duration will be ignored.
Should the external signal not be cancelled after a
regeneration sequence another time delay will occur.
Should the external signal continue beyond that point
an alarm condition will be displayed and additional
20 regenerations will be inhibited. The display will
indicate the presence of a signal and the remaining
time in minutes before a regeneration will occur.

Program types 71 and 72 are identical to type 70
except that the system will operate with two water
25 treatment systems, one of which will be on-line while
the other is regenerated and placed in standby. Only
one system will regenerate immediately after each
user set external signal duration occurs. The pair
will alternate as each new external signal duration
30 is reached. Simultaneous regenerations are not
possible.

35

1 WHAT IS CLAIMED IS:

- 1 1. A method for providing treated water on a
continuous basis with a variable water demand
5 employing a progressive flow water treatment system
having a first treatment tank and a second treatment
tank, and having a controller programmable by input
from an operator, the method comprising the steps of:
receiving an input designating a
10 progressive flow program type;
receiving an input for a total volume for
regeneration parameter;
receiving an input for a flow rate trip
level value;
15 controlling water flow to provide treated
water through the first treatment tank;
monitoring the flow rate of water through
the water treatment system;
comparing the flow rate to the received
20 trip level value;
controlling water flow through the second
treatment tank if the flow rate exceeds the trip
level value;
monitoring the total flow through each
25 treatment tank; and,
initiating a regeneration of each treatment tank
when total volume exceeds the input total volume
regeneration parameter.
- 30 2. A method as described in claim 1 wherein
the water treatment system includes a third treatment
tank, the method further comprising the step of
controlling water flow through the third treatment
tank if the flow rate exceeds twice the trip level
value.
- 35 3. A method as described in claim 1 further
comprising the step of controlling water flow through

-35-

1 the second treatment tank during regeneration of the
first treatment tank.

4. A method as described in claim 2 further
comprising the step of controlling water flow through
5 the treatment tank having the lowest total flow
during regeneration of other treatment tanks.

5. A method as described in claim 4 further
comprising the steps of:

receiving an input for a programmed time to
10 initiate regeneration of a tank;

calculating the average flow rate for each
tank;

calculating the time remaining until the
input total volume is reached;

15 comparing the calculated time to a
benchmark time of the programmed time plus time for
regeneration and brine makeup of the tank; and,

initiating regeneration of a tank if the
benchmark time exceeds the calculated time.

20 6. A method as described in claim 5 further
comprising the steps of:

monitoring the tanks to determine if a
regeneration is in process; and,

25 inhibiting the regeneration of each tank if
regeneration of another tank is in progress.

7. A method as described in claim 1 further
comprising the steps of:

30 designating one of the first and second
tanks as the initial primary tank to operate below
the trip level;

designating the other of the tanks as the
initial standby tank to be activated by the trip
level; and,

35 altering the designation of primary and
secondary upon the regeneration of either tank to
designate the regenerated tank as the standby tank.

-36-

1 8. A method as described in claim 2 further
comprising the steps of:
 designating a first one of the first,
second and third tanks as the initial primary tank to
5 operate below the trip level;
 designating a second one of the first,
second and third tanks as an initial standby tank
number 1;
 designating a third one of the first,
10 second and third tanks as an initial standby tank
number 2; and,
 altering the designation of the standby
tank number 2, upon completion of the regeneration of
any of the first, second or third one of the tanks,
15 to the newly regenerated tank.

20

25

30

35

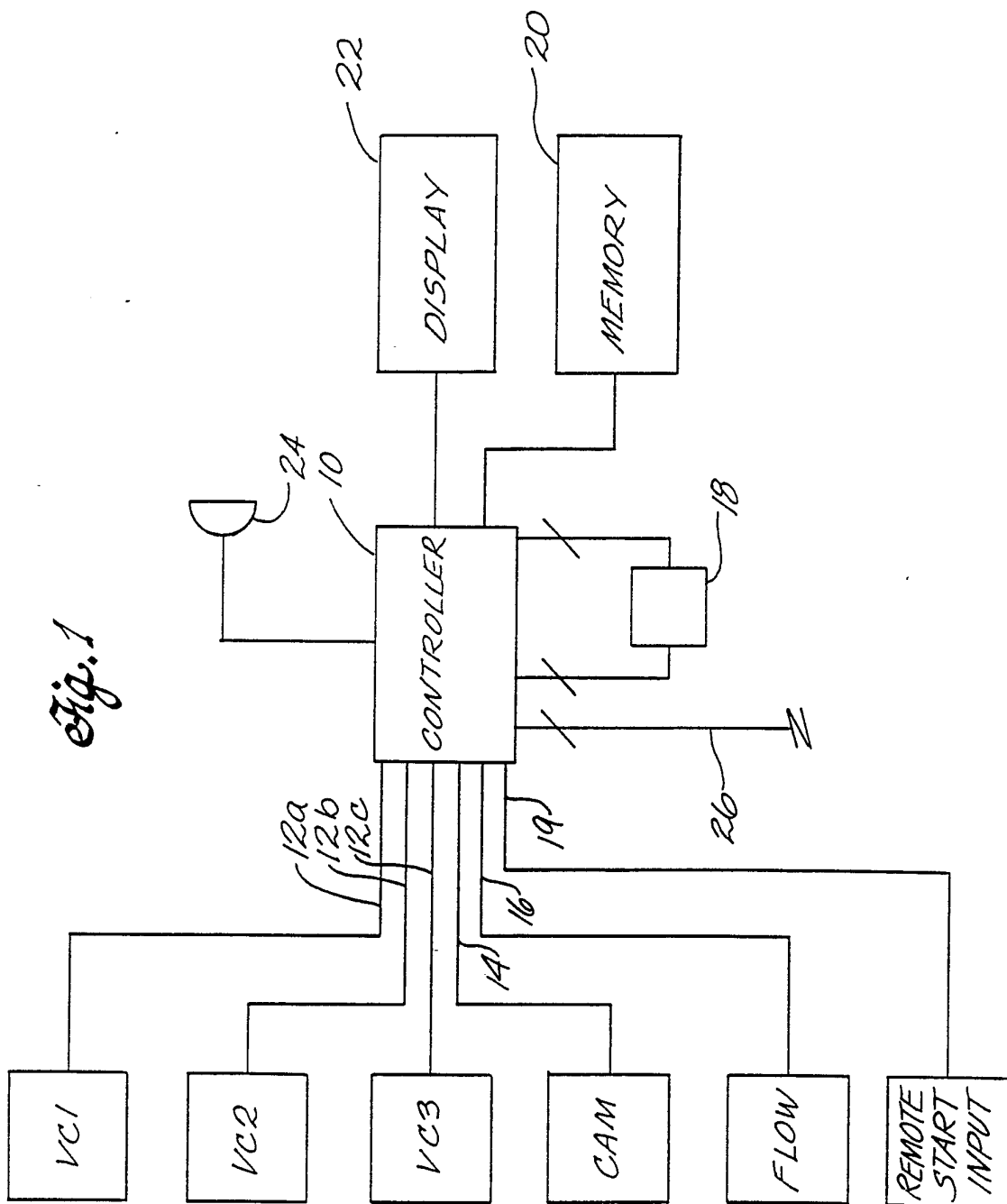

Fig. 2

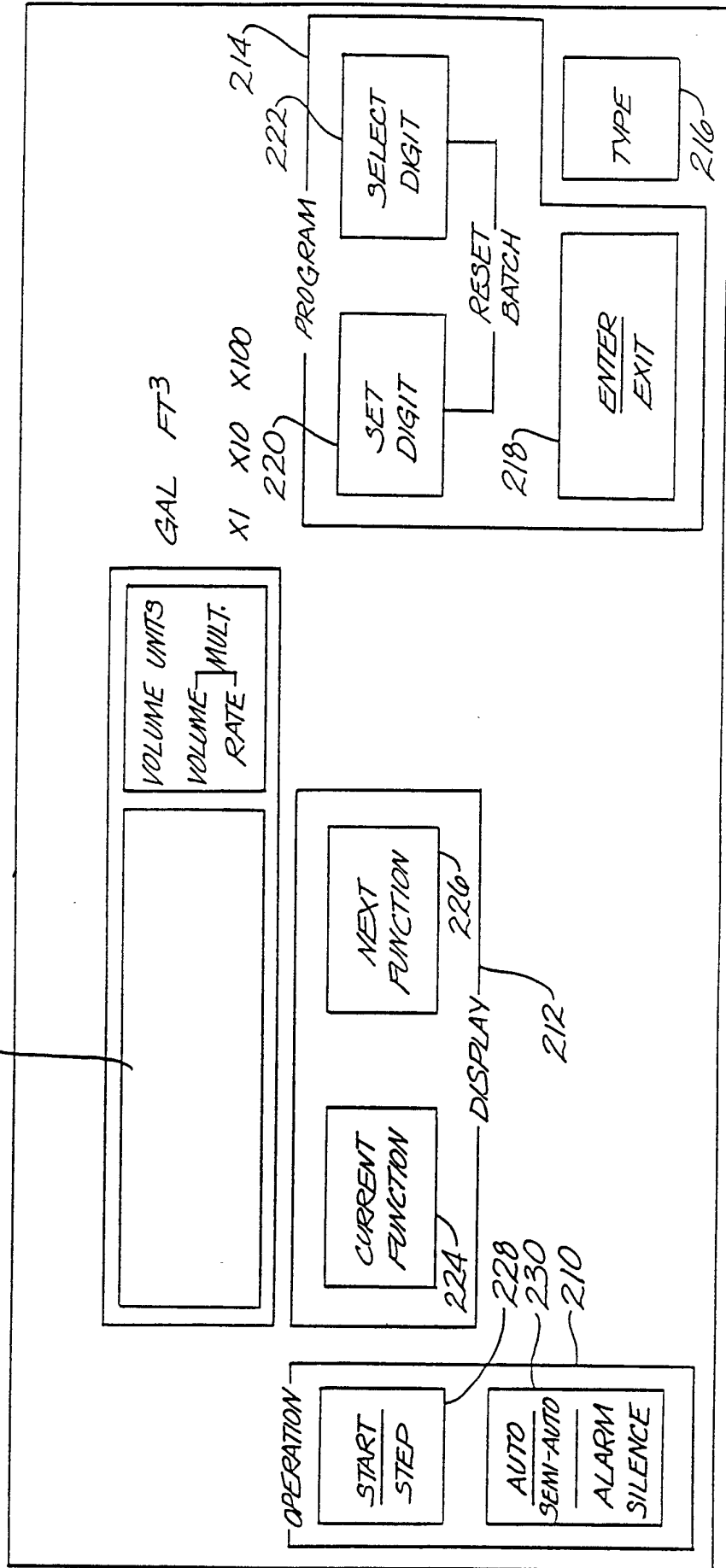

Fig. 3

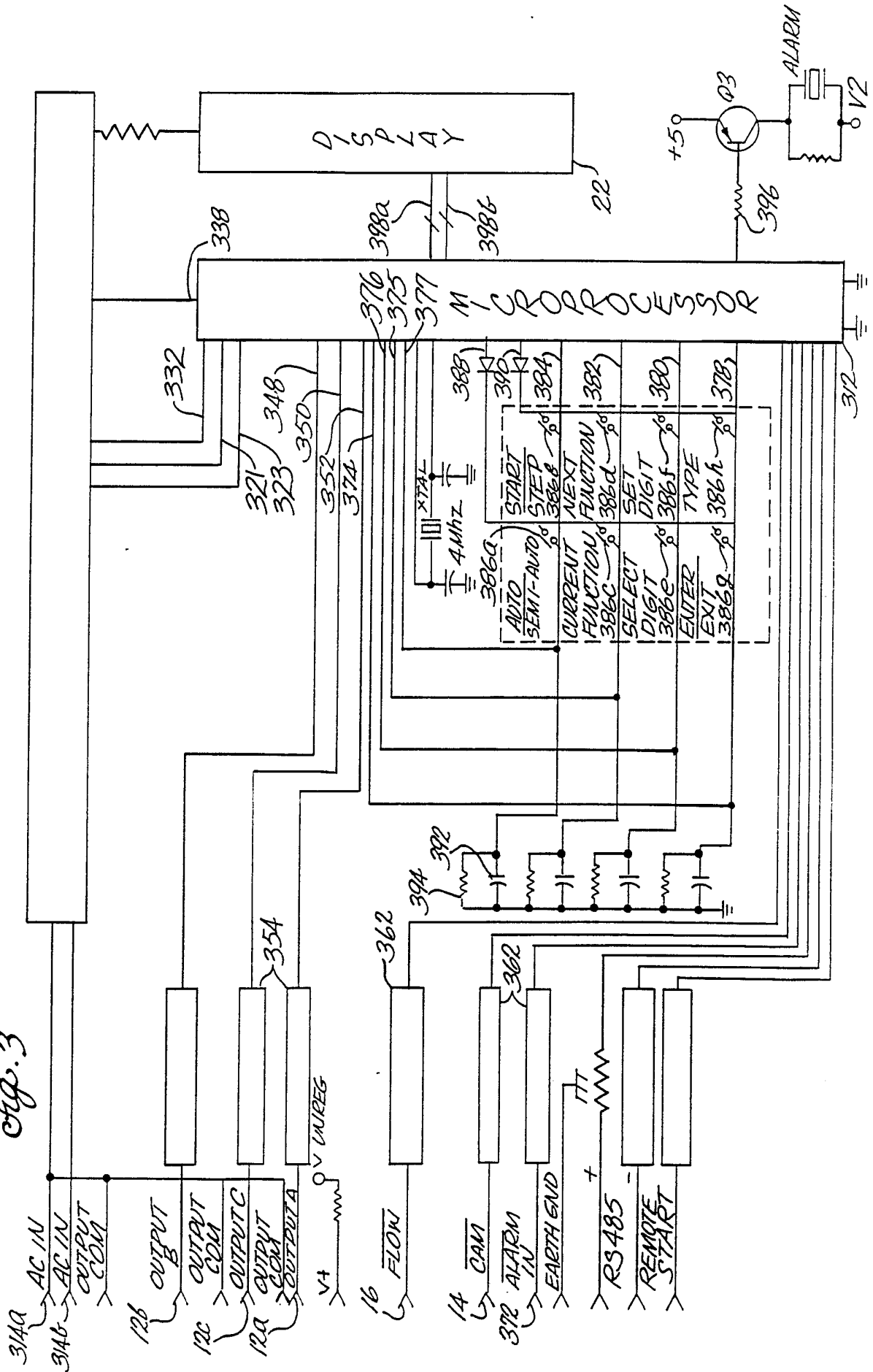

Fig. 46

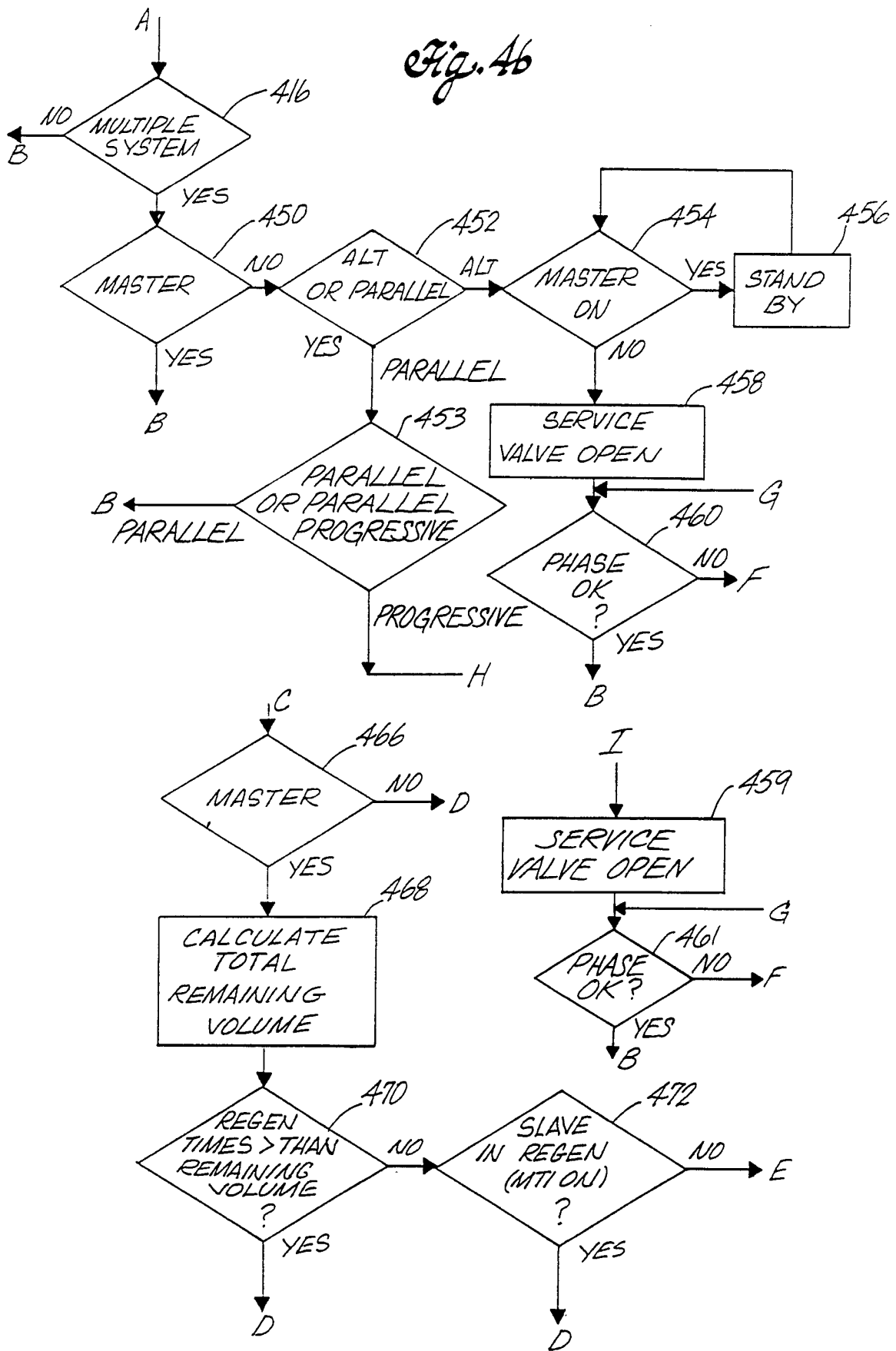

Fig 4c

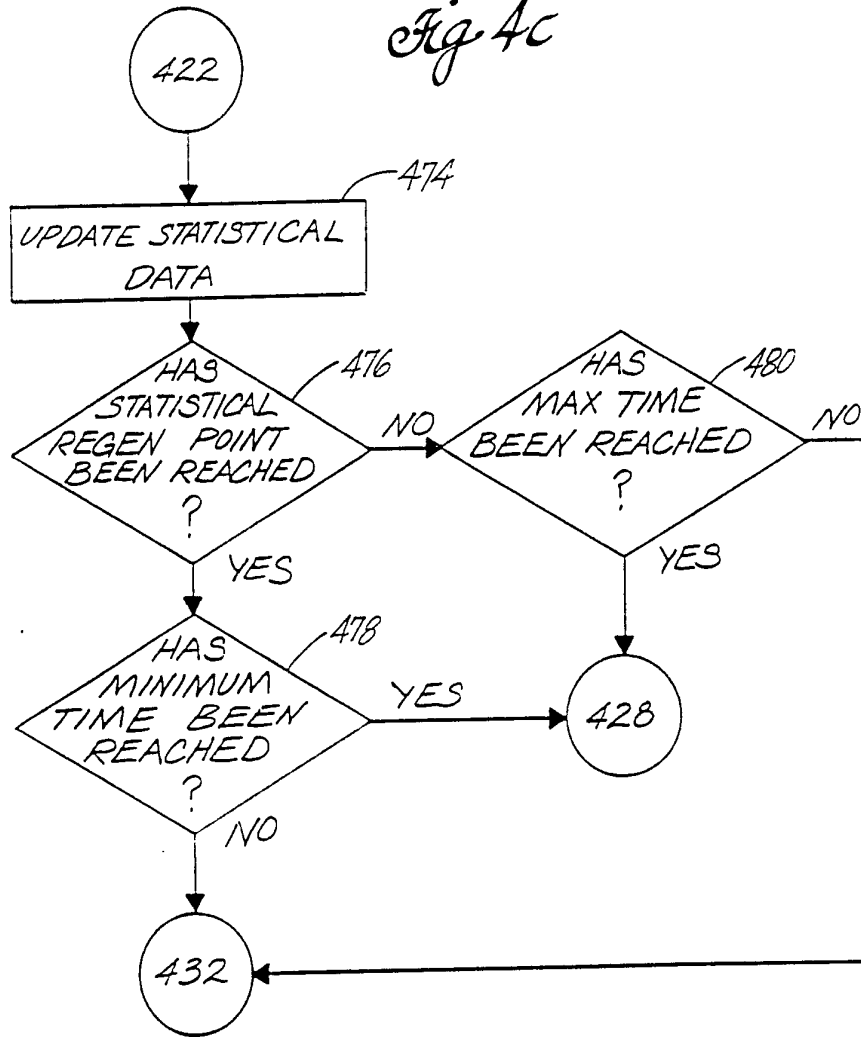

Fig. 4d

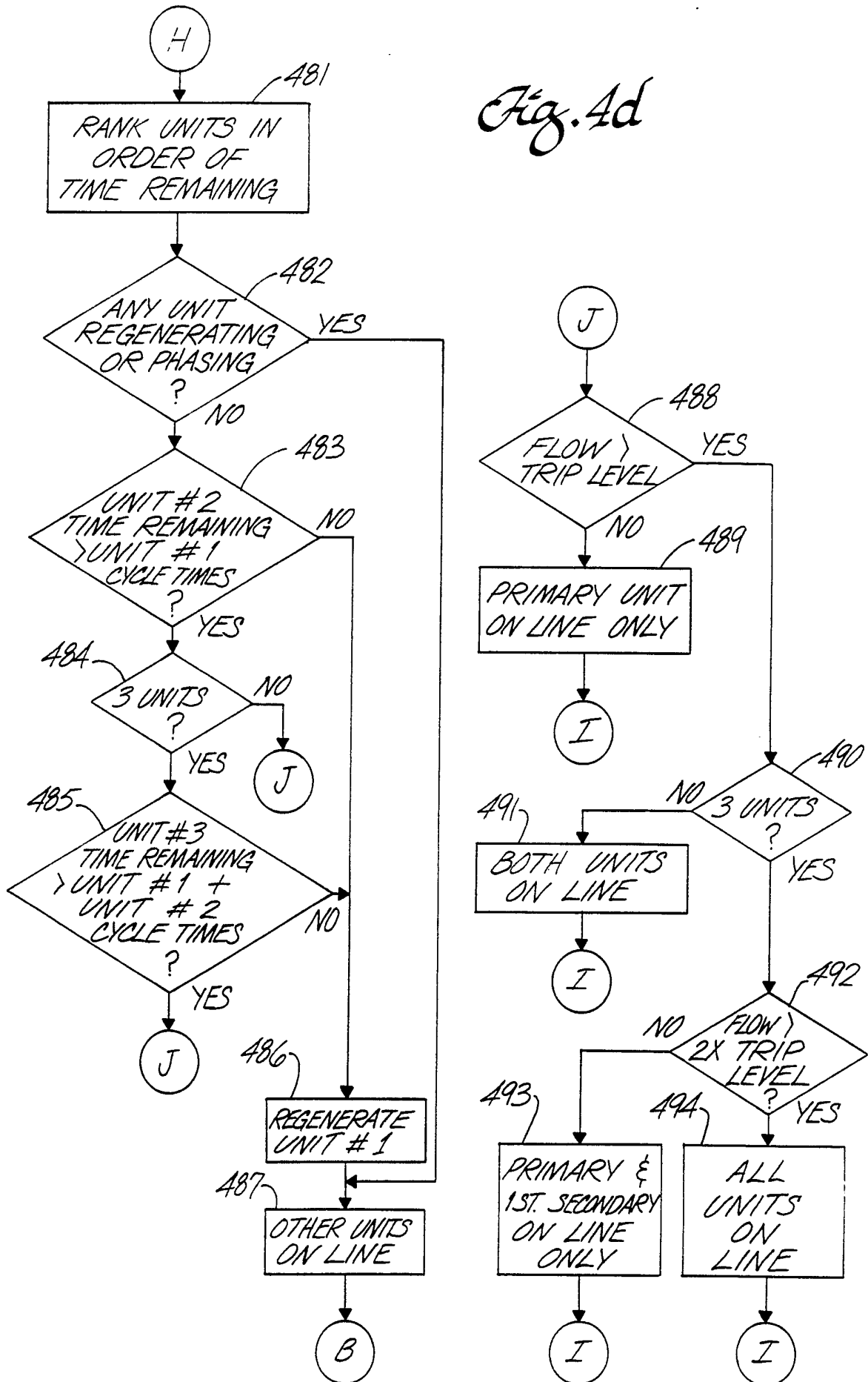

Fig. 5

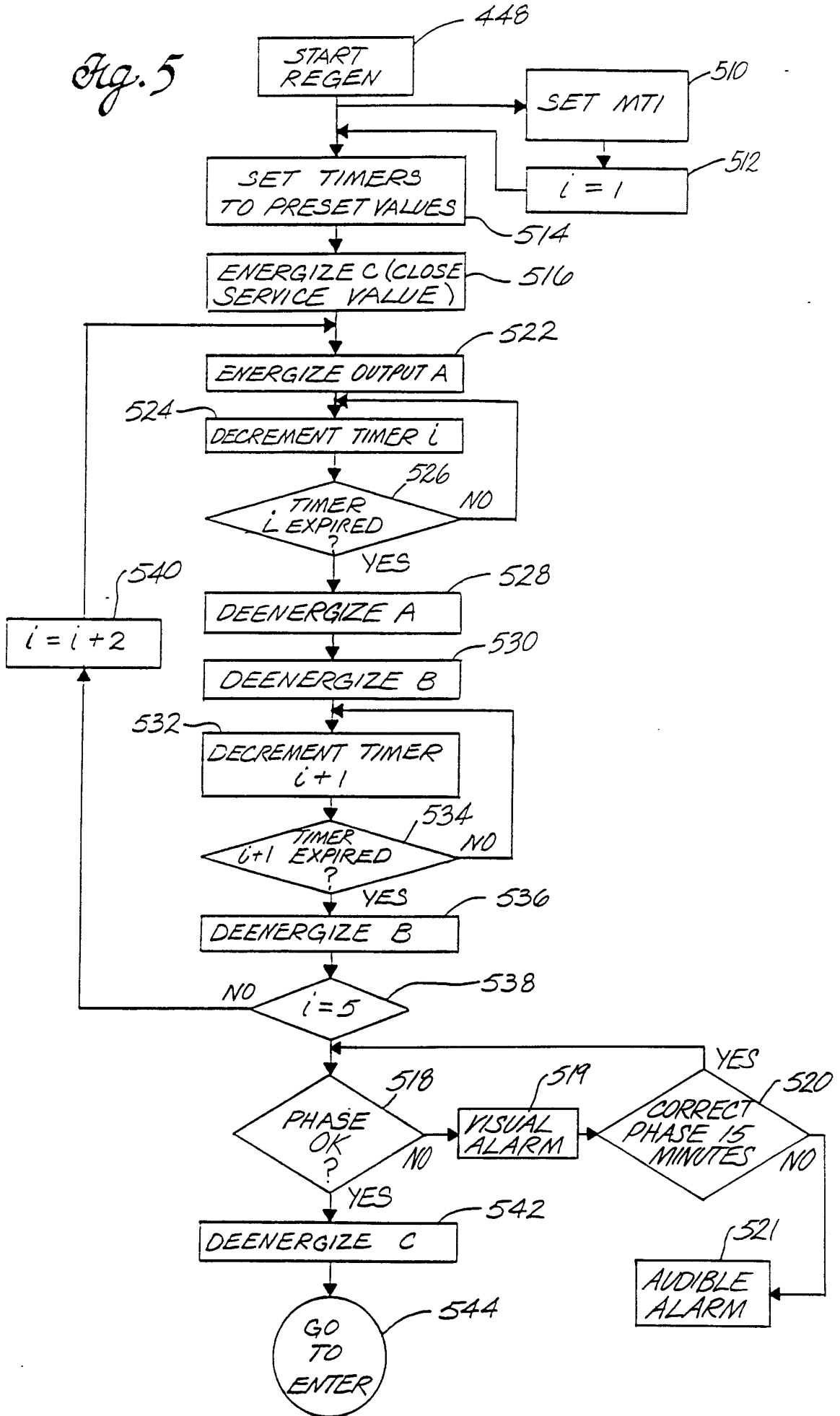

Fig. 6

TYPICAL PARALLEL FLOW

600 ↘

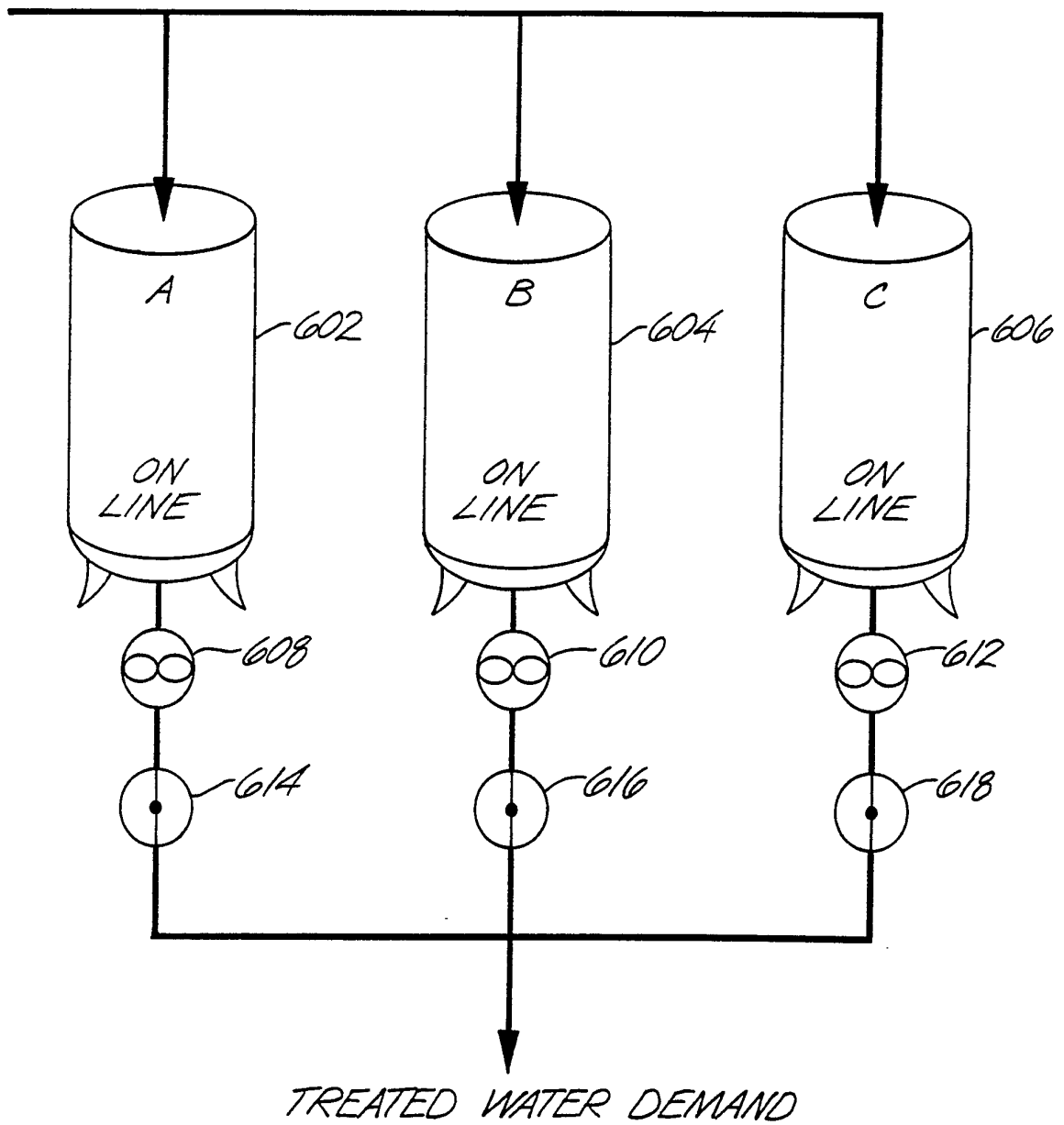

Fig. 7

*PROGRESSIVE FLOW
TRIP LEVEL 35GPM*

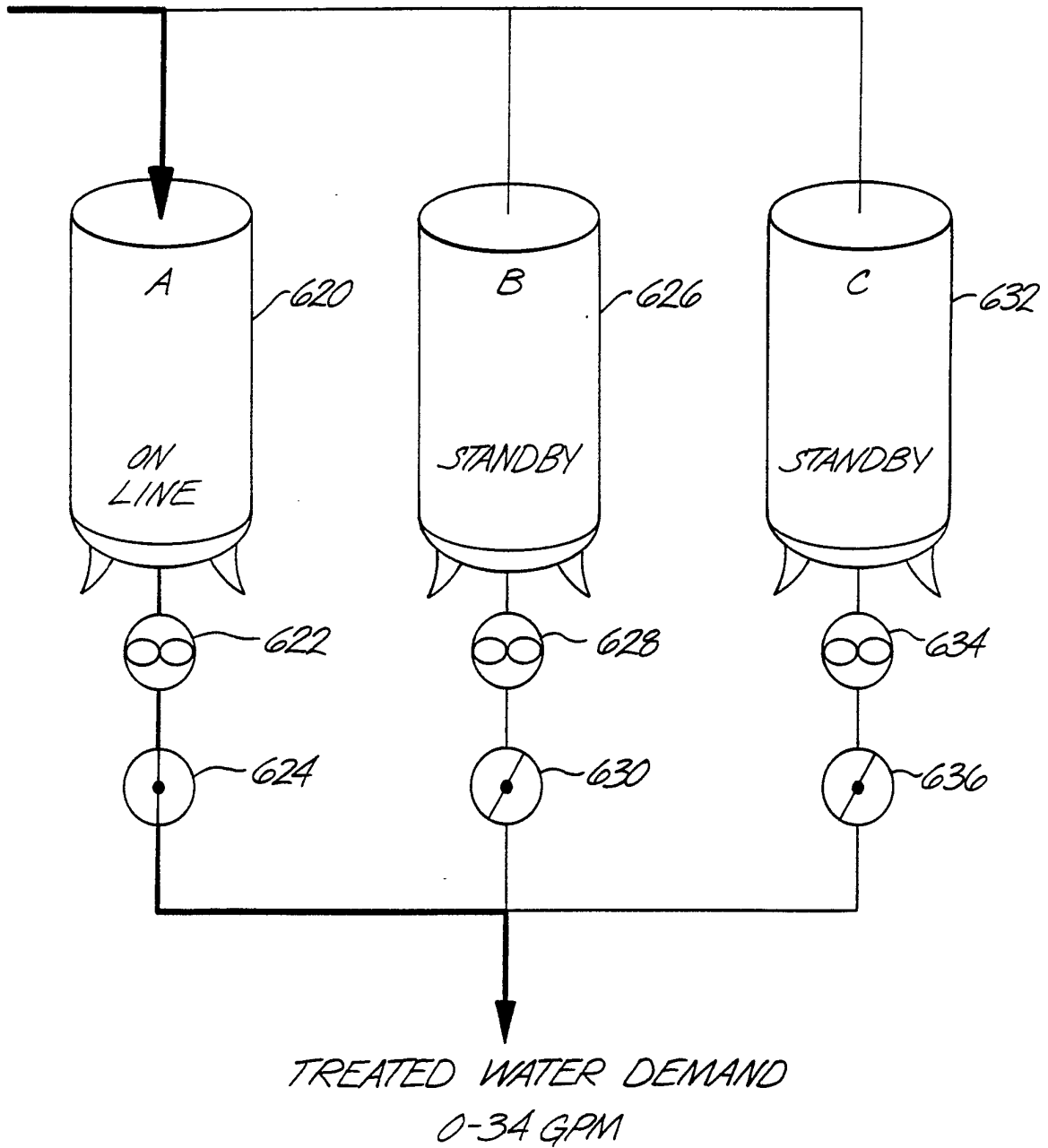

Fig. 8

*PROGRESSIVE FLOW
TRIP LEVEL 35GPM*

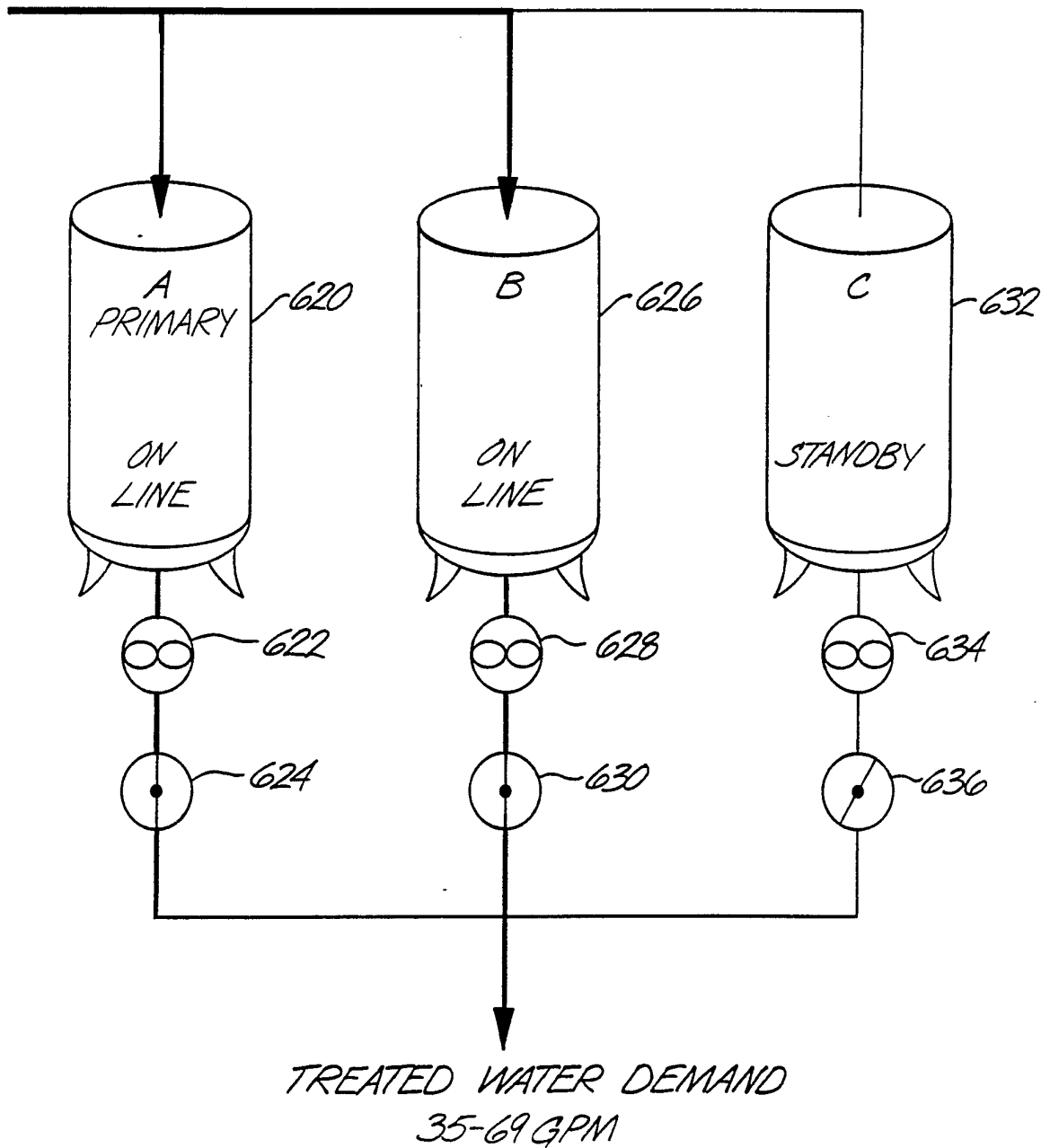

Fig. 9

*PROGRESSIVE FLOW
TRIP LEVEL 35GPM*

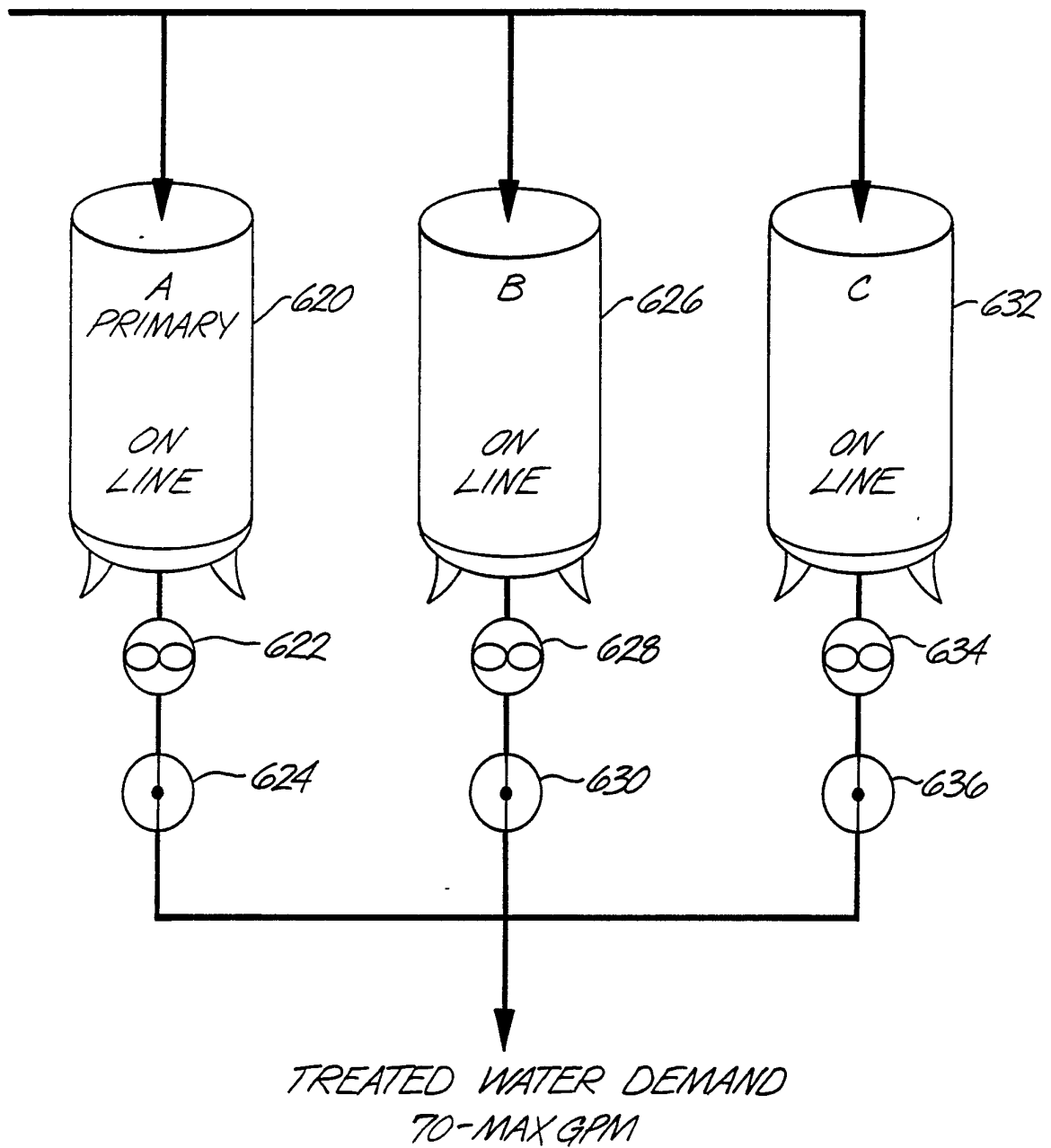
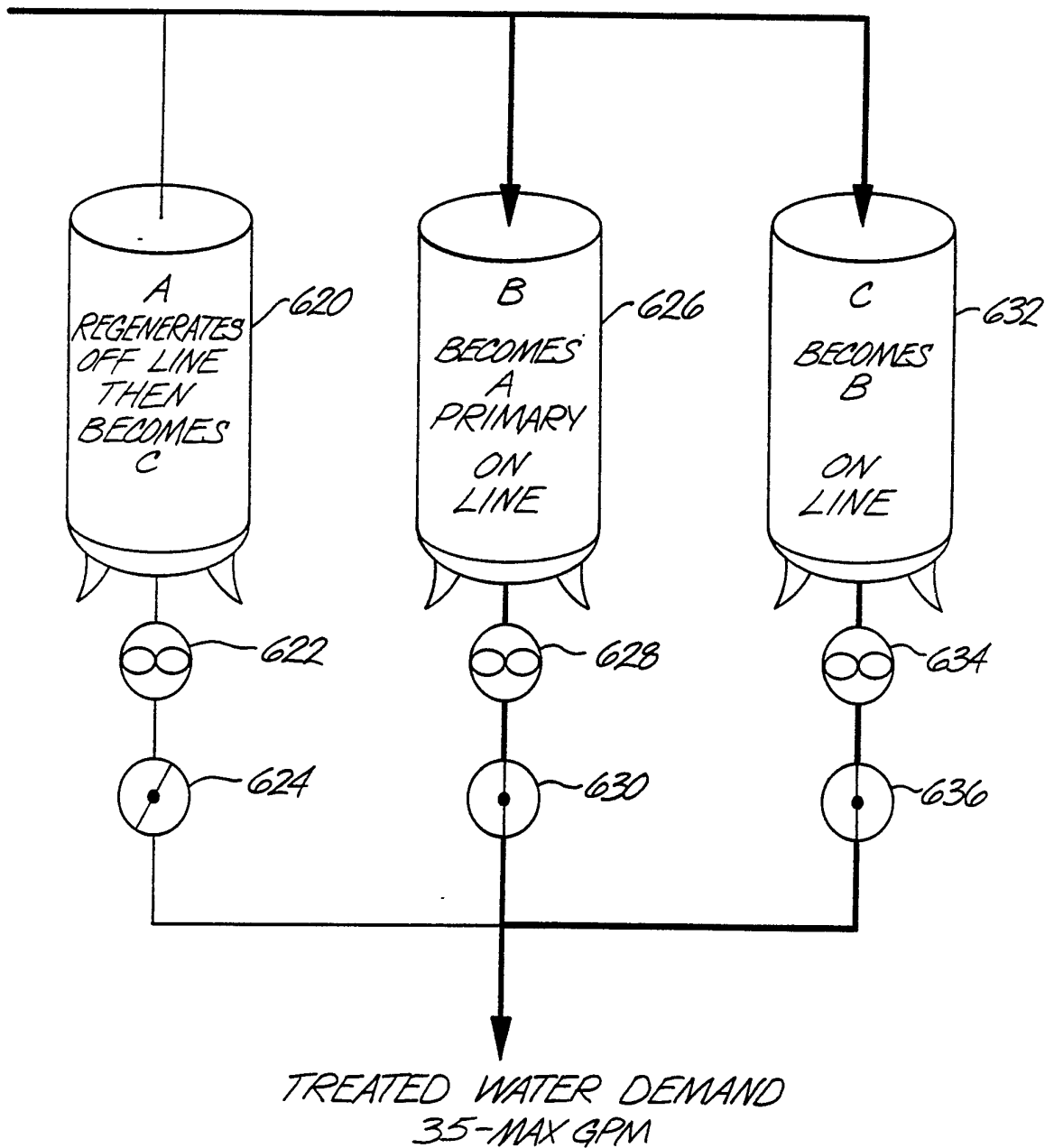

Fig. 10

*REGENERATION
PROGRESSIVE FLOW
TRIP LEVEL 35GPM*



INTERNATIONAL SEARCH REPORT

International Application

PCT/US 92/05277

I. CLASSIFICATION OF SUBJECT MATTER (if several classification symbols apply, indicate all) ⁶		
According to International Patent Classification (IPC) or to both National Classification and IPC		
Int.Cl. 5 B01J49/00		
II. FIELDS SEARCHED		
Minimum Documentation Searched ⁷		
Classification System	Classification Symbols	
Int.Cl. 5	B01J	
Documentation Searched other than Minimum Documentation to the Extent that such Documents are Included in the Fields Searched ⁸		
III. DOCUMENTS CONSIDERED TO BE RELEVANT⁹		
Category ¹⁰	Citation of Document, ¹¹ with indication, where appropriate, of the relevant passages ¹²	Relevant to Claim No. ¹³
Y	US,A,4 990 245 (WIEME) 5 February 1991	1-3
A	see column 1, line 60 - column 5, line 59; figure 5	4-7
Y	--- US,A,3 482 697 (TREMONT ET AL) 9 December 1969 see column 1, line 1 - column 4, line 43 see column 9, line 20 - column 10, line 41; figures 1-3	1,2
P,Y	--- US,A,5 060 167 (TICCIONI ET AL) 22 October 1991 see column 1, line 63 - column 13, line 46; figures 1-5	1,3
	---	-/--
<p>¹⁰ Special categories of cited documents:</p> <p>"A" document defining the general state of the art which is not considered to be of particular relevance</p> <p>"E" earlier document but published on or after the international filing date</p> <p>"L" document which may throw doubts on priority claim(s) or which is cited to establish the publication date of another citation or other special reason (as specified)</p> <p>"O" document referring to an oral disclosure, use, exhibition or other means</p> <p>"P" document published prior to the international filing date but later than the priority date claimed</p> <p>"T" later document published after the international filing date or priority date and not in conflict with the application but cited to understand the principle or theory underlying the invention</p> <p>"X" document of particular relevance; the claimed invention cannot be considered novel or cannot be considered to involve an inventive step</p> <p>"Y" document of particular relevance; the claimed invention cannot be considered to involve an inventive step when the document is combined with one or more other such documents, such combination being obvious to a person skilled in the art.</p> <p>"&" document member of the same patent family</p>		
IV. CERTIFICATION		
Date of the Actual Completion of the International Search	Date of Mailing of this International Search Report	
09 OCTOBER 1992	19. 10. 92	
International Searching Authority	Signature of Authorized Officer	
EUROPEAN PATENT OFFICE	CALARASANU	

III. DOCUMENTS CONSIDERED TO BE RELEVANT (CONTINUED FROM THE SECOND SHEET)		Relevant to Claim No.
Category ^a	Citation of Document, with indication, where appropriate, of the relevant passages	
A	US,A,3 932 279 (YOCUM) 13 January 1976 see column 1, line 55 - column 6, line 39; figures 1,2 ---	1,2,7,8
A	EP,A,0 423 923 (CULLIGAN INTERNATIONAL) 24 April 1991 see column 5, line 10 - column 12, line 58; figures 1-10 -----	1,2,4,5

**ANNEX TO THE INTERNATIONAL SEARCH REPORT
ON INTERNATIONAL PATENT APPLICATION NO. US 9205277
SA 61729**

This annex lists the patent family members relating to the patent documents cited in the above-mentioned international search report. The members are as contained in the European Patent Office EDP file on The European Patent Office is in no way liable for these particulars which are merely given for the purpose of information. 09/10/92

Patent document cited in search report	Publication date	Patent family member(s)	Publication date
US-A-4990245	05-02-91	None	
US-A-3482697	09-12-69	None	
US-A-5060167	22-10-91	None	
US-A-3932279	13-01-76	US-A- 3876539	08-04-75
EP-A-0423923	24-04-91	US-A- 5073255 CA-A- 2024430	17-12-91 06-04-91