

March 27, 1945.

I. F. MANDELL

2,372,385

CLOSURE SETTING MECHANISM FOR CONTAINERS

Filed Feb. 17, 1941

8 Sheets-Sheet 1

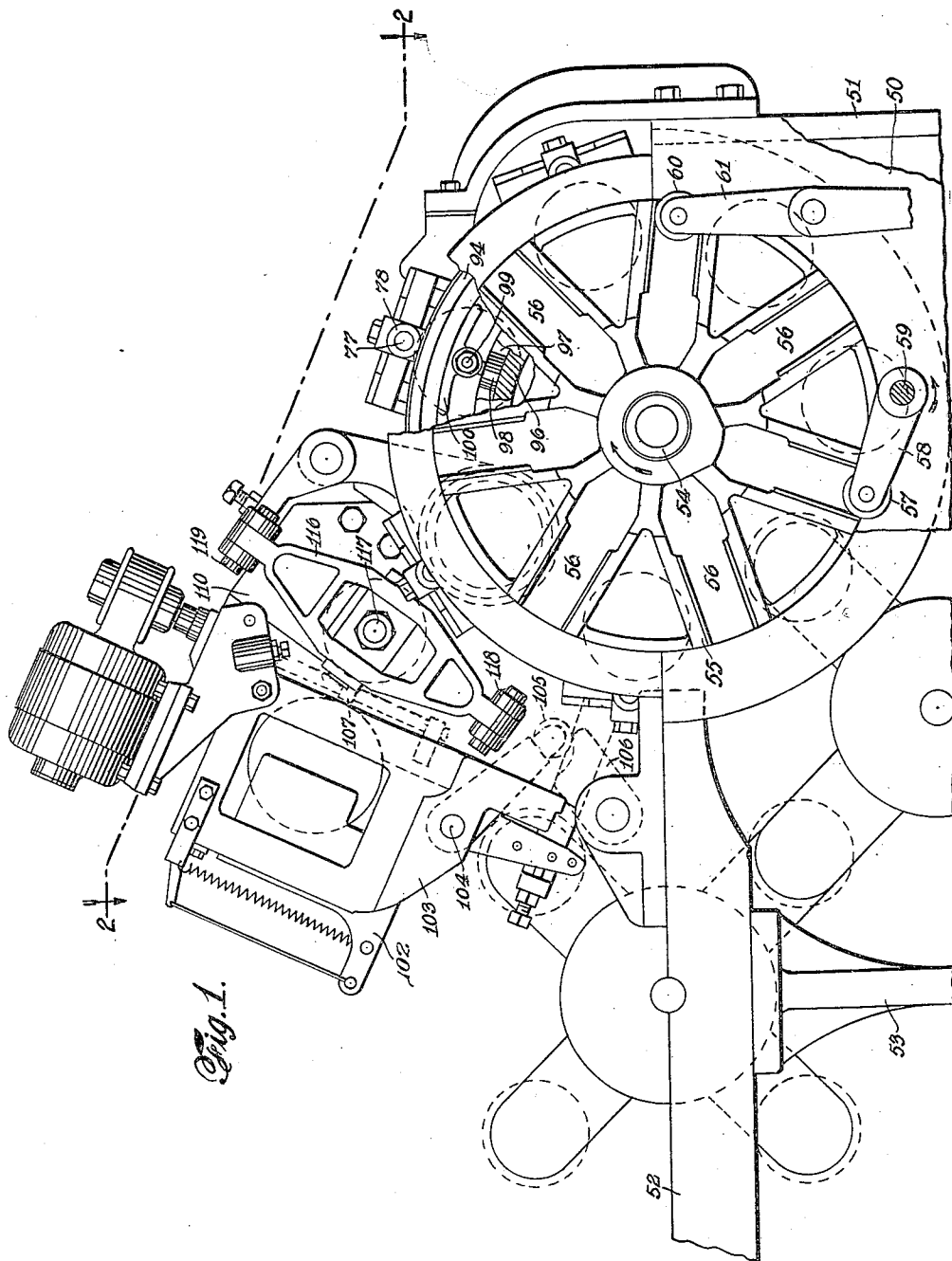

INVENTOR.
IRVING F. MANDELL

BY

Warren E. Willis.
ATTORNEY.

March 27, 1945.

I. F. MANDELL

2,372,385

CLOSURE SETTING MECHANISM FOR CONTAINERS

Filed Feb. 17, 1941

8 Sheets-Sheet 2

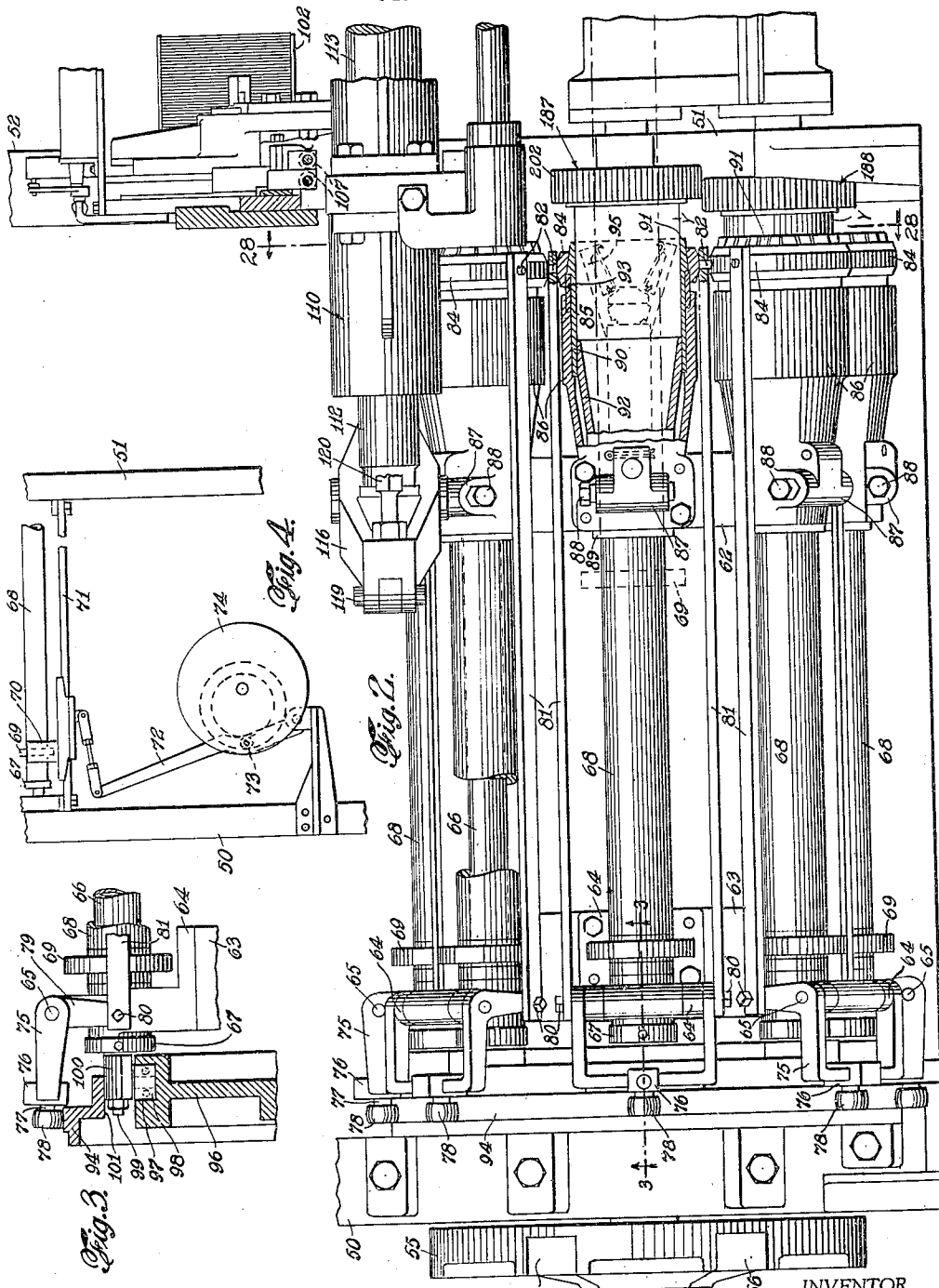

INVENTOR.
IRVING F. MANDELL

BY

Warren E. Willis
ATTORNEY.

March 27, 1945.

I. F. MANDELL

2,372,385

CLOSURE SETTING MECHANISM FOR CONTAINERS

Filed Feb. 17, 1941

8 Sheets-Sheet 3

Fig. 5.

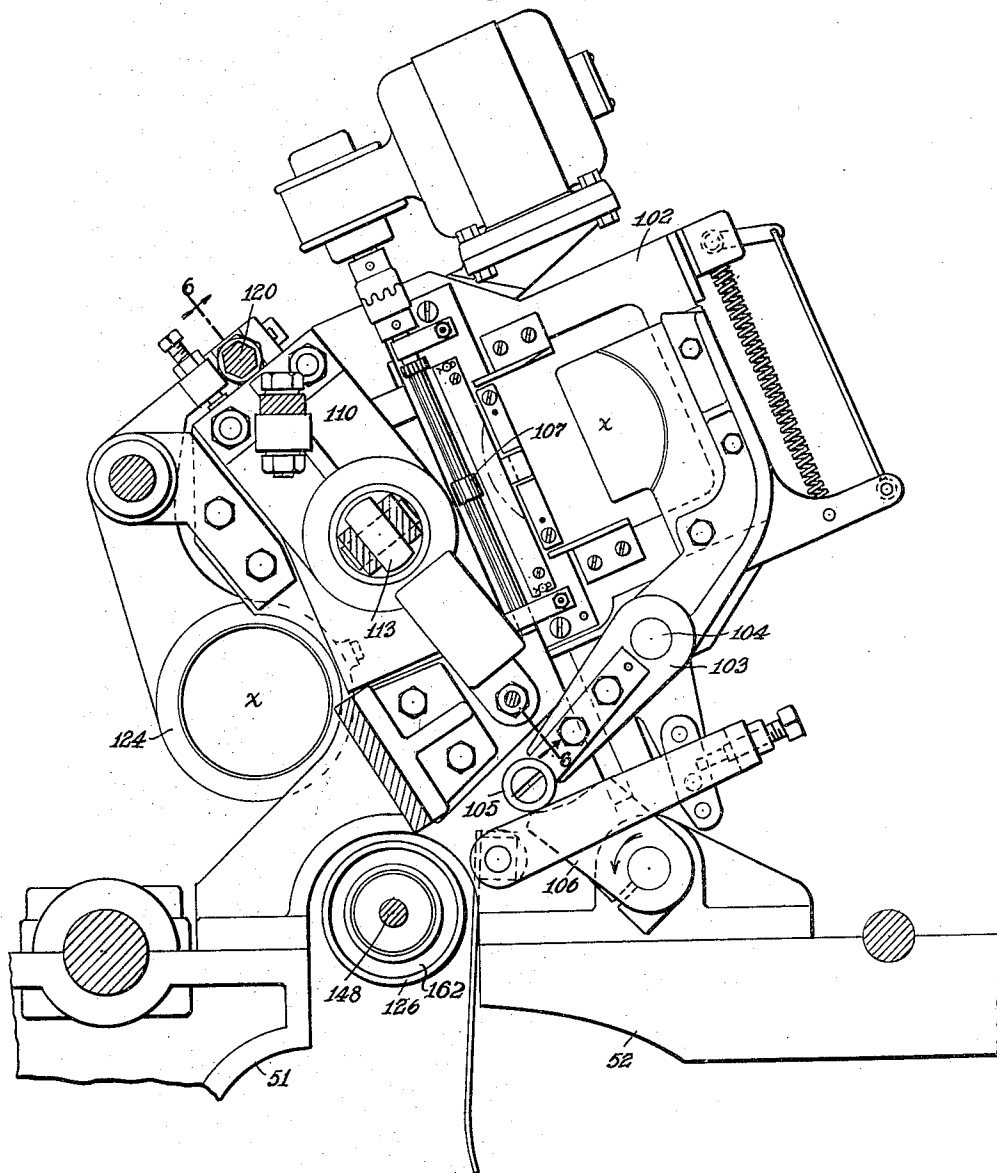

INVENTOR.
IRVING F. MANDELL

BY

Warren E. Willis.
ATTORNEY.

March 27, 1945.

I. F. MANDELL

2,372,385

CLOSURE SETTING MECHANISM FOR CONTAINERS

Filed Feb. 17, 1941

8 Sheets-Sheet 4

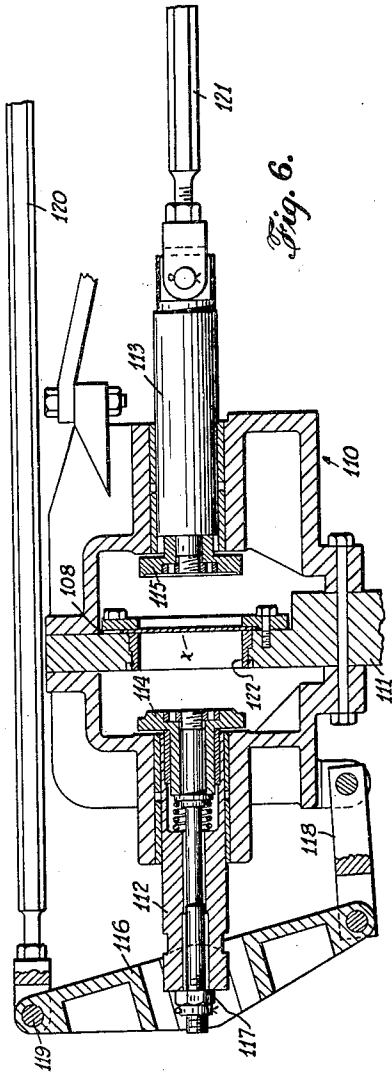

Fig. 6.

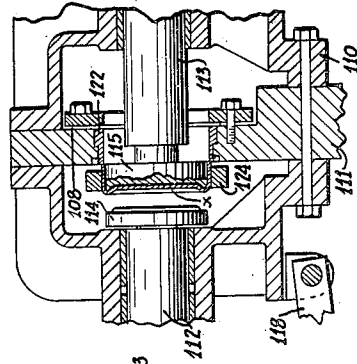

Fig. 9.

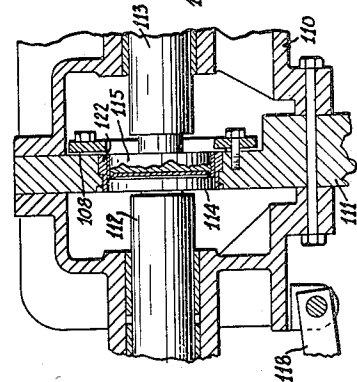

Fig. 8.

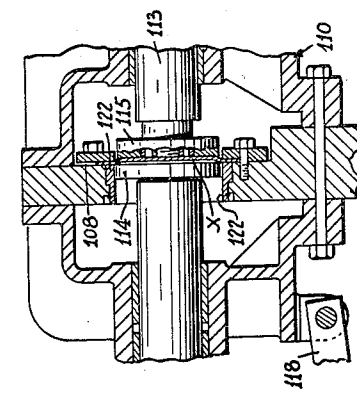

Fig. 7.

INVENTOR.
IRVING F. MANDELL.

BY

Warren E. Willis.
ATTORNEY.

March 27, 1945.

I. F. MANDELL

2,372,385

CLOSURE SETTING MECHANISM FOR CONTAINERS

Filed Feb. 17, 1941

8 Sheets-Sheet 5

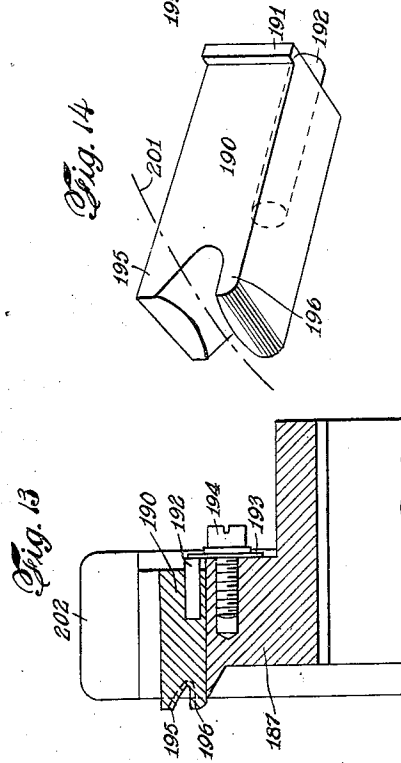
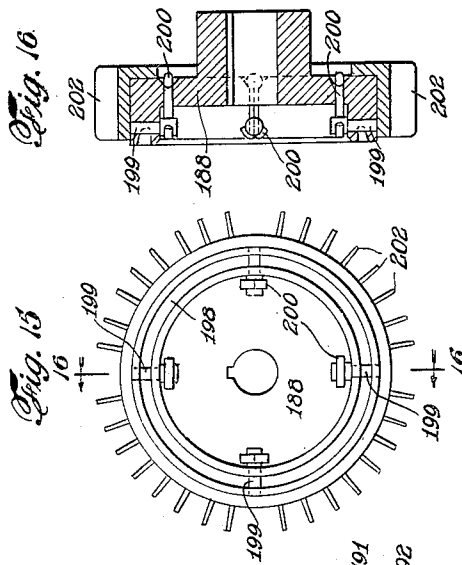
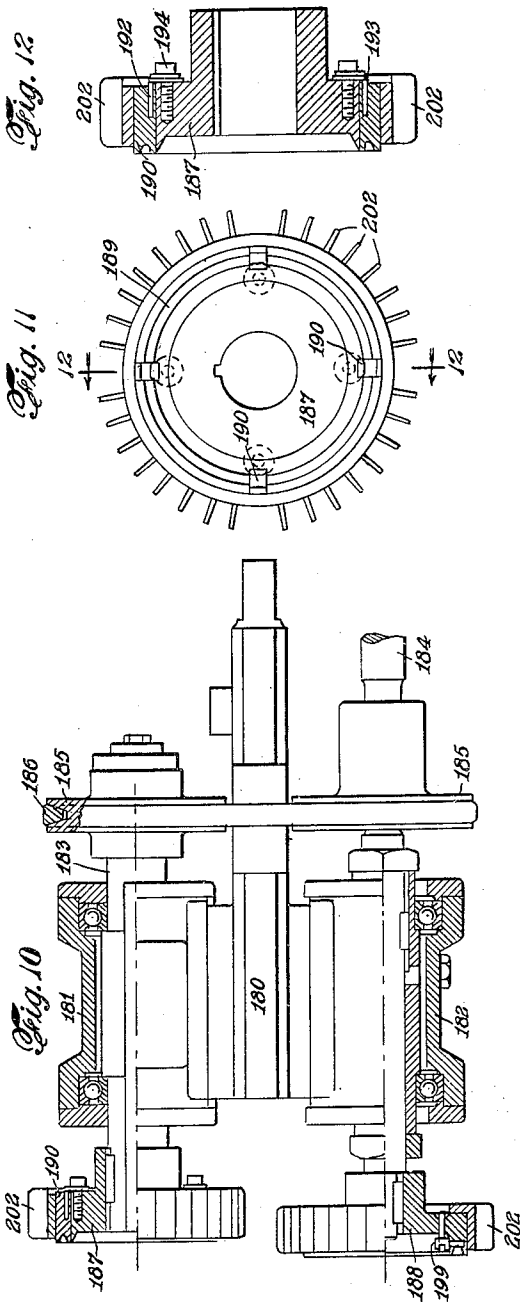

BY

INVENTOR.
IRVING F. MANDELL

Warren E. Willis
ATTORNEY.

March 27, 1945.

I. F. MANDELL

2,372,385

CLOSURE SETTING MECHANISM FOR CONTAINERS

Filed Feb. 17, 1941

8 Sheets-Sheet 6

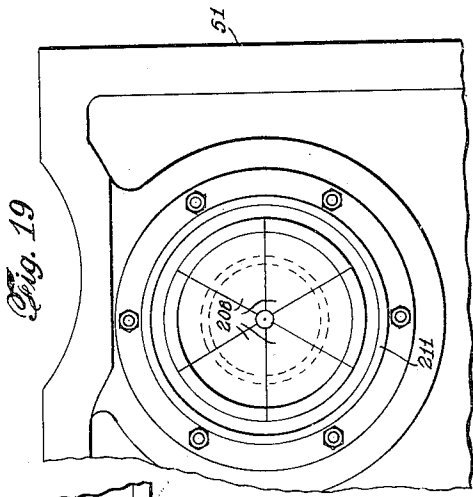

Fig. 19

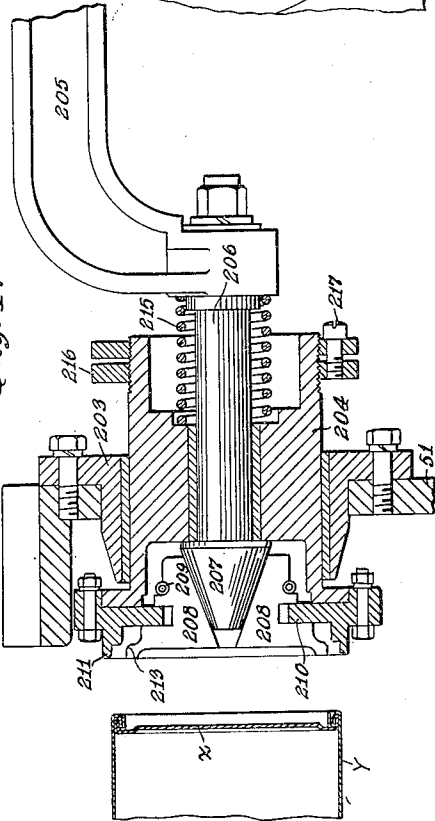

Fig. 17

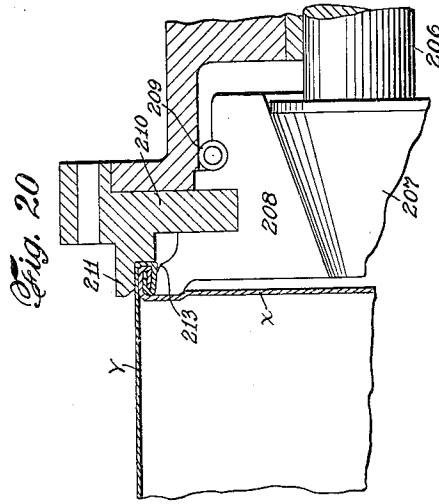

Fig. 20

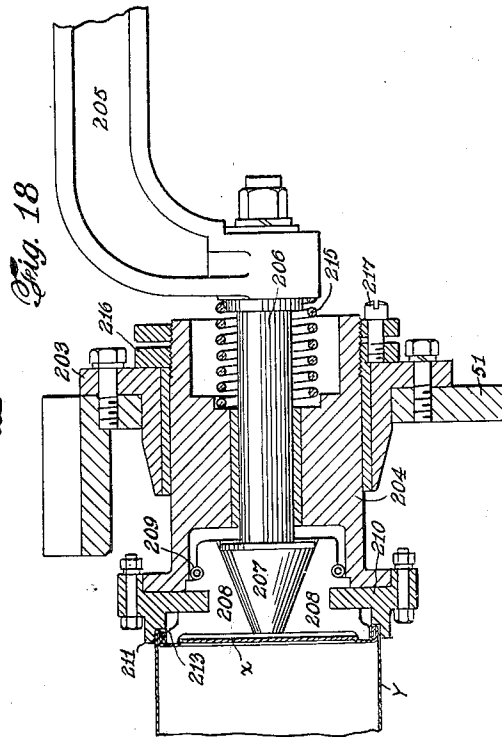

Fig. 18

INVENTOR.
IRVING F. MANDELL

BY

Warren E. Willis.
ATTORNEY.

March 27, 1945.

I. F. MANDELL

2,372,385

CLOSURE SETTING MECHANISM FOR CONTAINERS

Filed Feb. 17, 1941

8 Sheets-Sheet 7

Fig. 21

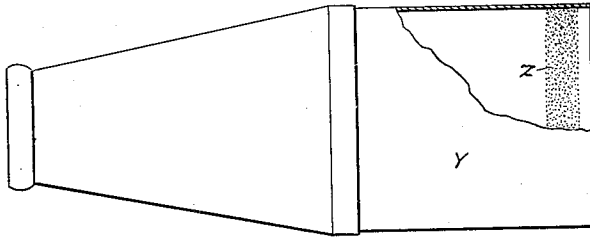

Fig. 22

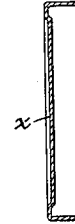

Fig. 23

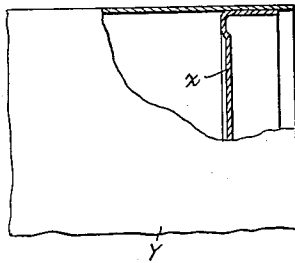

Fig. 24

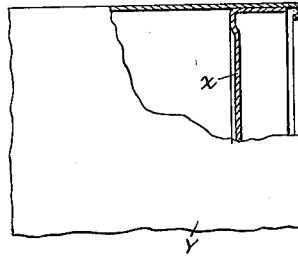

Fig. 25

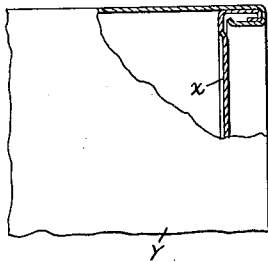

Fig. 26

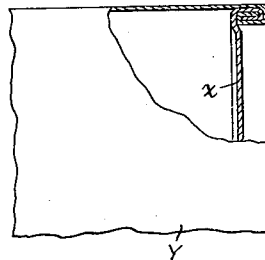
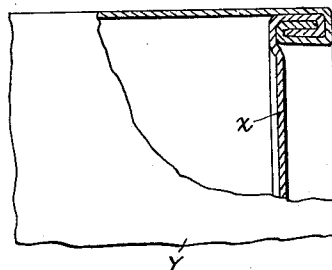

Fig. 27



BY

INVENTOR.
IRVING F. MANDELL

Warren E. Willis.
ATTORNEY.

March 27, 1945.

I. F. MANDELL

2,372,385

CLOSURE SETTING MECHANISM FOR CONTAINERS

Filed Feb. 17, 1941

8 Sheets-Sheet 8

Fig. 28

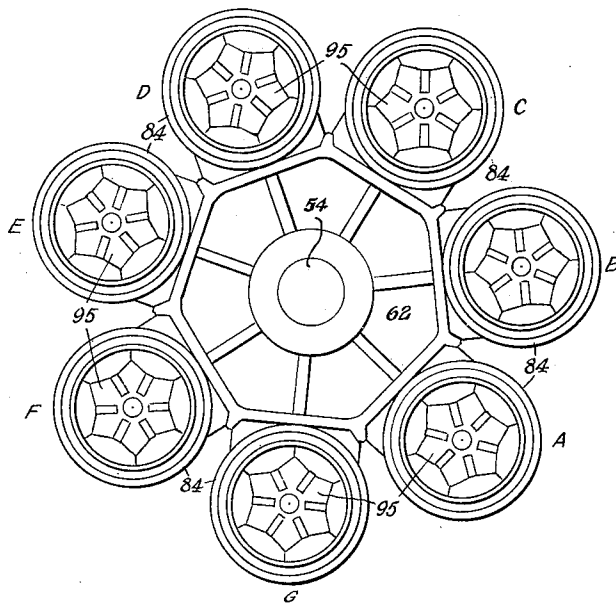
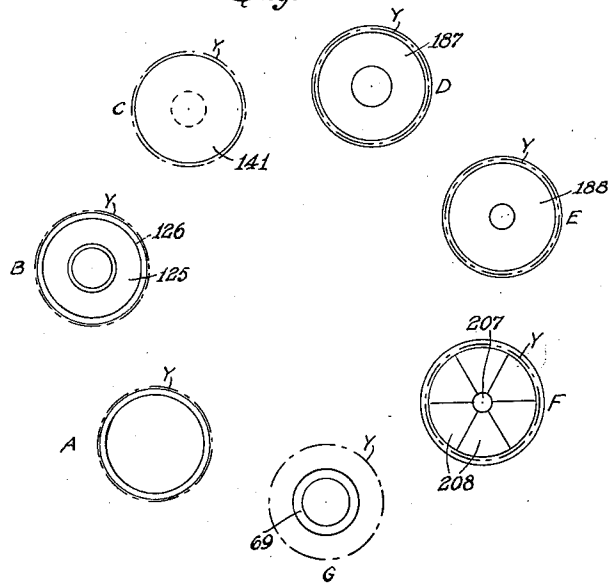

Fig. 29



INVENTOR.
IRVING F. MANDELL

BY

Warren E. Willis.
ATTORNEY.

UNITED STATES PATENT OFFICE

2,372,385

CLOSURE SETTING MECHANISM FOR CONTAINERS

Irving F. Mandell, New York, N. Y.

Application February 17, 1941, Serial No. 379,390

20 Claims. (Cl. 93—55.1)

This invention relates to mechanisms for securing closures in cylindrical containers, made of paper or like material, at either or both ends.

Obviously, such containers of this type as are adapted for service as holders of liquids must have impermeable body walls, a bottom capable of resisting internal and external pressures, and be proof against leakage under rough usage.

The main object of the invention is to provide mechanism, including spinning devices of different characteristics required in shaping the edges of a container body wall, and its inserted bottom, to form an interlocked curled joint during the closure inserting process.

Another purpose of this invention is to produce a simple, adjustable mechanism for pressing the inter-locked closure to insure positive adhesion.

With the foregoing general objects in view, the specific purpose of the present invention is directed to the formation of a bottom in a paper container, including the preparation of a bottom closure element, application of an adhesive band to the inner surface of the body, entry of the closure element therewithin, and infolding and clinching of these elements in an effective inter-locked manner, to produce an efficient, strong and leak-proof joint wholly within the confines of the body.

These objects are attained by the novel construction and combination of mechanisms hereinafter described and illustrated in the accompanying drawings, constituting a comprehensive component of this disclosure and in which:

Figure 1 is a side elevational view of an embodiment of the invention, in which one side of the bottom closure forming and feeding mechanism is shown.

Figure 2 is a partial plan view, taken on line 2—2 of Figure 1, some parts being shown in section.

Figure 3 is a fragmentary sectional view, taken on line 3—3 of Figure 2.

Figure 4 is a fragmentary view of parts of the structure shown in Figure 2.

Figure 5 is a view looking at the opposite side of Figure 1, showing the bottom closure feeding mechanism, some parts being in section.

Figure 6 is a longitudinal sectional view, taken on line 6—6 of Figure 5, showing a bottom closure element in position to be formed.

Figure 7 is a fragmentary view, similar to Figure 6, but showing parts in advanced, operative positions.

Figure 8 is a fragmentary view, similar to Figure 6, but showing the parts in further advanced positions.

Figure 9 is a view similar to Figures 6—8, showing a formed closure member entered into a transfer ring.

Figure 10 is a plan view, partly in section, of an assembled spinning head for forming jointure seams on container shells and associated bottom closures.

Figure 11 is a front elevational view of the spinning head in detail.

Figure 12 is a transverse sectional view, taken on line 12—12 of Figure 11.

Figure 13 is an enlarged fragmentary sectional view of the structure shown in Figures 10 and 12.

Figure 14 is an enlarged perspective view of a grooved shaping member of the first spinning head.

Figure 15 is a front elevational view of a second spinning head of the assembly of Figure 10.

Figure 16 is a transverse sectional view, taken on line 16—16 of Figure 15.

Figure 17 is a longitudinal sectional view of the bottom seam pressure mechanism.

Figure 18 is a view similar to Figure 17, but showing parts in different positions.

Figure 19 is a partial front end elevational view of the pressing mechanism.

Figure 20 is an enlarged fragmentary view of the parts shown in Figure 17.

Figure 21 is a side elevational view of a container having a portion broken away to show an adhesive band therein.

Figure 22 is a transverse central sectional view of a bottom closure insert.

Figure 23 is an enlarged fragmentary view of the container shown in Figure 21, together with the closure member of Figure 22.

Figure 24 shows an initial curl imparted to the bottom of the container shell by the first spinning head.

Figure 25 shows the operation advanced to bring the initial curl into a position to engage in the closure member recess, thence to be directed along the face of its skirt, this being partly accomplished by the second spinning head.

Figure 26 shows the jointure seam after completion by the second spinning head.

Figure 27 shows the seam after operation thereof by the pressing mechanism.

Figure 28 is a diagrammatic view taken on the line 28—28 of Figure 2, and showing positions of operating stations at the container shell housings.

Figure 29 is a diagrammatical view taken on the same line, but looking in the opposite direction, and identifying stopping stations and working parts.

Referring in greater detail to the drawings, the numeral 50 generally designates one of the sides of the machine frame, which, together with a corresponding opposite side, rear central frame 51 and central bridge bar 52 supported by uprights 53 are fixed on a base, not shown.

Carried by the frame members are bearings

for a hollow shaft 54, its front end extending outwardly, beyond the frame 50, and firmly fixed upon the shaft is a wheel 55, of the Geneva type, having formed in its face seven equally spaced slots 55.

Adapted to engage in these slots is a roll 57, carried on a continuously revolving crank arm 58, of commonly used type, fast on a drive shaft 59, the roll engaging successively in each individual slot, causing an intermittent, step-by-step partial rotation of the wheel 55.

A locking roll 60, on a cam actuated arm 61, is moved in timed relation to engage successively in the slots 56 during the intermittent suspensions of wheel motion, which are regular and uniform in duration.

Fixed on the shaft 54, at the inner side of the frame 50, is a spider 63 having seven radial lugs 64 provided with extending transverse pins 65; these lugs have openings therein through which pass end portions of sleeves 66, parts of a collapsible mandrel mentioned later, having securing nuts 67. (See Figure 3.)

Also fixed on shaft 54 adjacent the frame 52 is another spider 62 supporting housings mentioned later.

Slidable on the sleeves 66 are quills 68, on each of which is a fixed collar 69; engageable with the collars, as the spider moves from one station to another, is a shifter block 70, slidably mounted on a fixed rail 71. (See Figure 4.)

Pivoted to the shifter block is a link attached to the end of an arm 72 having a roller 73, oscillated by a cam 74 in timed relation; thus, at each part revolution of the wheel 55, and the members associated therewith, one of the collars 69 enters the groove in the shifter block 70, whereupon the collar and quill are moved to eject a container, as hereinafter more fully apparent. The shifter block 70, by reason of the timed oscillatory arm 72, then returning to release the collar for the succeeding operations.

Pivotaly mounted on the ends of the pins 65 are bell-crank levers, their forwardly reaching arms 75, constituting yokes containing heads 76, from each of which projects a stud 77 carrying a cam roll 78.

The other arms 79 of the bell-crank levers carry studs 80 loosely engaging the forward ends of bars 81, while the rear ends of the bars are engaged by pins 82, set in rings 84 over spring collet structures 85 revolvable with the shaft 54.

Housings 86, having conical rear ends mounted on the spider 62 are disposed exteriorly of the quills 68, the housings each having lugs 87 in which are bolts 88 to secure a conical guide member 92.

Within the housings, the collets 85 have at their fronts slotted cylindrical portions 91, constituting resilient segments tending to expand, while the terminal portions of the segments, over which the rings 84 pass, are suitably tapered.

Rigid guiding and positioning rings 93 are secured within the housings 86 to engage the rear, outer portions of the spring segments 91 of the sleeves.

The container guide 92 has a bearing member 89 to guide the forward end of quills 68.

The rolls 78 of the bell-crank arms 75 travel on cam tracks 94, adapted to rock the bell-cranks and move the rings 84 in opposite directions, thereby contracting or releasing the spring segments 91 to grip or relax a container body with the housing.

Operable within each housing 86 is a collapsible

mandrel, generally indicated by the numeral 95, and fully disclosed in a prior Mandell Patent No. 2,181,816.

The mandrel 95 is operated in association with a cam device 96 fixed to the frame 50 and has a track groove 97, in which is movable a cam follower or roll 98, disposed on a stud which projects from an end 99 of the mandrel operating rod.

The extremity 99 of this rod has an arcuate guide member 100 movable within flanges 101 of the cam track 94 thereat.

Disposed above the housing 86 and cooperating therewith, during the stepping movement of the wheel 55, is a magazine 102 containing flat circular, bottom forming, disc-like paper elements X, which are fed individually, from the left hand of the magazine, see Figures 1 and 5, by means which include one end of a lever 103, pivoted at 104, and having at its opposite end a roll 105, cooperating with an actuating cam 106 as shown.

From the lever 103, the discs are fed between geared rolls 107, into position in a space 108 in the closure forming mechanism 110, having a central member 111, and in which plungers 112—113 operate. The plunger 112 carries a die 114, having a raised central major portion, and on the plunger 113 is a cooperating die 115, having a depression corresponding with the raised portion of the die 114.

The plunger 112 is relatively movable at its outer end by a cross link member 116 at a pivotal connection 117, and is hingedly connected at one of its ends with another link 118, hinged to part of the mechanism 110, and its opposite end 119; the link member 116 is pivotally connected with operating means including a rod 120, while the plunger 113 is operated by means which include a rod 121.

Cooperating with these dies, is a rigid ring 122, and as the plungers 112—113, having the closure element therebetween, are urged into the position shown in Figure 3, the outer marginal portion of the paper disc is so drawn into the ring 122 as to form an inverted cup shaped bottom closure member X, including a formed crown and pendant annular skirt, then ready, as to shape, for insertion into the lower end part of a container shell Y.

From the plunger 115 the formed bottom closure is urged into the ring portion of a pivotal transfer member 125 where it is ready, after the dies 114—115 are withdrawn and the transfer member moved to the transfer position, for insertion into container shell Y, having at that time an adhesive band Z therein, this being at a point herein identified as the third station C. The adhesive band is applied by an expansible, elastic roll 162 (see Fig. 5), at a definite distance from the open end of the container, all as fully described in the Mandell Patent No. 2,284,491.

It is to be noted that there are in this machine seven stopping places or stations, there being a station for each of the seven container body shell carrying housings, including the outer housing 86. The housing may be seen as in Figure 28, looking towards the left, from a line corresponding with the ends of the housings, at the rings 84, Figure 2.

Figure 29 is a diagrammatic view looking in the opposite direction from the same line. The housings of Figure 28 are represented in broken lines in Figure 29, where the mechanisms and devices for acting on the body shell ends, in association with the bottom closure elements, are diagrammatically identified.

Thus, at the first station A, a container shell Y, without a bottom, is inserted in a housing 86, momentarily stopped, the length of time at each stop being the same. As a shell Y is being inserted at the first station A, an adhesive applying operation by means of an expansible elastic roll, is being performed at the second station B; insertion of a closure cap at the third station C; a first spinning operation at station D; second and complete spinning at the fifth station E; pressing of a bottom seam at station F, thus completing the bottom affixing operation, and ejection of a completely bottomed container at the seventh station G.

These seven operations are all performed simultaneously during one stop, on different containers. On the next or second stop, for example, the shell Y that was inserted, during the previous stop at station A, now has an adhesive Z applied thereto, at station B. At a third stop, the shell that was inserted and adhered at stations A and B, has a bottom closure member inserted at the third station C. In this way a container shell, and a bottom closure member, are inserted at each stop, and a completely bottomed container is also ejected at each stop. The ejection is made into a delivery train (not shown), and the formation of a container shell is likewise performed in a part of the instant machine, but not included in this application.

In Figure 10 and those immediately following, spinning mechanism is shown for curling and turning in the coacting bottom end wall of the container body shell Y and the skirt of the preformed cup-shaped bottom closure X. A head carrying means, including a central member 180, has fastened on its opposite sides barrel elements 181—182 substantially alike, and provided with bearings therebetween; there are two heads, a first spinning, and a second and more advanced spinning head.

The first spinning head includes a stud shaft 183, and the second head has a drive shaft assembly 184. These shafts have keyed pulleys 185 and are revoluble in unison by a belt 186, and keyed to the respective shafts are spinning heads 187—188.

The first spinning head 187 is provided with a curl forming groove 189, and set in recesses in the head are a plurality of formers 190, which, as seen in Figure 14, have at their rear ends retaining flanges 191. Also in their rear ends are openings, in each of which is a pin 192, engaged in each case by a retaining plate 193 and screw 194.

The formers 190 have an outer jaw 195 convexly curved for engaging a shell bottom edge portion, and an inner jaw 196 is correspondingly convex. Between the jaws, in which the bottom edge of the shell is caused to travel, the curved structure is also of convex formation.

The face of the second head 188 has an annular groove 198, in which the partly curled edge engages. Pins 199 pass through the outer annular portion of the head, those pins being retained by cotter pins 200; these pins are so arranged as to pass crosswise through the innermost part of the annular groove 198, so as to suitably engage and form the crest of the seam or bead of the jointure.

Referring to Figures 21 and 27, it is noted that during the rotary movement of the formers 190, of the first spinning head, a portion thereof, as on the line 201 (Figure 14), engages the single

marginal edge portion of the shell of the container and tends to curl and turn it inwardly, the edge being passed along part of the face of the jaw 195 and around to the inner jaw 196 to form this initial curl.

This is an important feature and step in the formation of an efficient, strong and reliable seam, and it is advisable, in practice, not to advance the first spinner any further than is sufficient to turn in the flange portions to the equivalent of an angle of 180 to 240 degrees from the outer surface of the container shell.

Initially turning the wall of the shell with the formers of the first spinning head 187, of relatively smaller forming characteristics than the second spinning head, is an advantage, since it imparts a leading curl to the edge, which is maintained, during operation with the second spinning head 188. The curl of Figure 24 tends to meet the outer boundary of the cup-shaped bottom closure X, Figure 25, in which is formed an annular recess adjacent its skirt wall, the curl being then passed along the inner face of the skirt portion of the cup-shaped closure, thus forming a fivefold seam, Figure 27.

Since the friction caused by the insert elements of the spinning heads on the wall of the shell Y and closure X, causes material heat by abrasion and produces some dust-like particles, fins or fan blades 202 are secured to the outer members of the head for removing the air containing such particles, from the parts being operated upon.

Bottom seam pressing and finishing mechanism is disclosed in Figures 17 to 20 which consists of a frame 51, to which is secured a bearing 203 for a plunger 204, part of an assembly moved by a reinforced arm 205. A stud shaft 206 is fixed to the arm 205 and has a tapered terminal 207, around which are segments 208, drawn inwardly by an endless coil spring 209 and having outward guided movement on a plate structure 210, which includes a rigid annular keeper ring 211, adapted to fit outside of a seam on a bottom and shell.

The shaft 206 also has movement relative to an interposed bearing 203, and the segments 208, as a combined unit, are formed to fit against the closure seam of the bottom member and container shell with its crown and annular recess thereat, there being arcuate parts 213, which engage at the recess and against the inner face of the seam of the bottom.

The plunger 206 is advanced in Figure 18, against the action of a spring 215 which holds the pressing assembly in adjustable position when in forward end of its motion by a threaded ring 216, held in locked position when adjusted by a screw 217, the terminal 207 being effective to bring about the result described.

The spring also serves to hold the pressing member in position against the container until the shaft 206 has moved far enough to contact the pressing elements.

Pressing of the seam is performed just after application of the adhesive and the seam is subjected to some possible stress on the adhered parts during the spinning operation, it is a particular advantage to utilize the keeper ring 211, thereby maintaining the proper contour of the exterior of the container.

Variations may be resorted to within the scope of the invention, and parts of the improvements may be used without others.

Having thus described the invention, what is

claimed as new and sought to secure by Letters Patent, is:

1. In a machine for bottoming paper containers, an apparatus for forming a circular disc into an inverted cup-shaped closure having a resilient circular skirt, comprising a plate having an opening and means therein for releasably holding the margin of the disc, a reciprocatively movable plunger including a die having a straight cylindrical recess in register with the opening in said plate, an opposed reciprocatively movable plunger including a die having an elevation opposite the recess, the plungers to engage the disc and form an offset annular ring thereon, the second mentioned plunger movable in timed relation with the other plunger, whereby to draw the marginal portion of the disc into the opening to produce a cylindrical skirt element on the disc, said skirt springing slightly outward after being released from said dies.
2. In a machine for securing closures in paper containers having cylindrical body portions, an apparatus for forming an outwardly springable cup-shaped end closure member from a paper disc, comprising a plate having means for releasably holding the margin of a paper disc, said plate having an opening centrally of the holding means, a reciprocatively movable plunger including a die having a central annular recess, an opposed reciprocatively movable plunger including a cooperating die having a raised portion corresponding with the mentioned recess, said plungers movable cooperatively to form an offset annular indentation in the disc, said second plunger movable into the mentioned opening, together with the other plunger and disc, whereby to draw said margin from the holding means to produce an annular skirt on the disc circumjacent its offset indentation, said skirt when released having a tendency to spring outwardly.
3. In a container bottoming machine, means for holding cylindrical container shells with closure members attached within the bottom ends of the shells, a spinning head having rigid inserted shaping members for partly seaming one container end, a second head substantially like the first head and farther advanced in the machine, the second head having adjustable shape forming members for completing the seams, both heads being operable on adjacent containers concurrently, and means coupling said heads for simultaneous spinning movement.
4. An apparatus comprising, in combination, removable means for internally backing the outermost margin of a bottom closure cup of a conventional bottle shaped paper container, means for forming a seam on the skirt portion of the cup and the end part of the container thereat, an annular device for supporting the seam externally on the line of contour of the container, and means for pressing the seam against its supports to insure adhesion, all of said means being linearly movable.
5. In a paper container machine comprising an intermittently revolvable wheel having a bearing, a holder to receive and release the cylindrical shell of a container, said holder comprising a sleeve having spring clamping segments, said segments having an annular row of projections thereon, a ring movable on said segments, and longitudinally movable means cooperating with said bearing and with said ring to draw the ring over the projections thereby to clamp and/or release a shell.
6. In a container end closure setting machine, a device for pressing the folds of a closure seam on one end of a cylindrical container body shell and a closure skirt therein, the closure having a support within the container, comprising an axially movable head having a supporting band fitting around the exterior of the shell and seam, a plurality of segmental expansible formers engaging the seam opposite its support, and means for expanding said formers whereby to engage the inner face of the seam and press the latter outwardly against said supporting band.
7. A machine for affixing cup shaped closures in the ends of cylindrical paper container body shells, comprising a carrier having an intermittent rotary movement and embodying plural housings, each housing adapted to carry a shell, said carrier having stopping stations corresponding with the number of housings, devices located at each of said stations for performing separate operations on the closures and associated parts of the shells, there being one device for each station, each housing adapted to receive a shell at one station, there being one shell in each housing, said devices including an expansion roll for applying a band of adhesive within a shell near the end thereof during one stop of the carrier, means for inserting a closure so that its skirt portion engages the adhesive band, two independent spinning devices for forming associated closure skirt elements and body shell portions therein into an interlocking seam, means for pressing the folds of the seam together, and means for ejecting a shell with its closure and seam from said carrier during the aforesaid stop.
8. A machine for affixing cup shaped closures in ends of cylindrical paper container body shells, comprising an intermittently revolvable carrier having a plurality of housings, each housing adapted to carry a shell, said carrier having an equal number of stopping stations, devices coacting at the several stations and disposed substantially axial with the respective housings for performing separate operations on the closures and associated parts of the shells, there being one device for each station, said devices including means for inserting a shell into a housing at one station during one stop of said carrier, means for acting upon a body at each of the other stations during each single stop, said means including an expansible roll for applying a band of adhesive within the shell at the end portion thereof, a device for entering a closure member so that its outwardly springable skirt portion engages the adhesive band, a spinning device of relatively small curl forming characteristics for preliminarily turning in said end portion, a second spinning device of relatively large curl forming characteristics for forming said shell end portion and closure skirt into an interlocking seam, each of said spinning devices consisting of a plurality of adjustably mounted rigid forming units, a device for pressing the folds of the seam together, and means for ejecting a container from its housing when at the last station.
9. A device for simultaneously forming seams on two paper containers having cylindrical body portions and having bottom closure elements within the bodies, the closures having skirts adhesively engaging within the end portions of the respective container bodies which extend beyond the closure skirts, comprising a first revolvable head and a second revolvable head farther advanced than the first head, said first head having a curling groove providing an outer contact and an inner contact, said head continually spun

about its axis and advanced, the outer contact being first urged against the end edge of one container, the margin urged along the concave part of the groove and along the inner contact and thence to the closure at the base portion of its skirt whereby to partially form a seam, the container moved to register with said second head, and the second head applied to the seam, said second head substantially similar to the first head and similarly revolvable, the first head then applied to engage a second container, and the second head arranged to urge the partial seam of the first container further inwardly, each of said heads being composed of a plurality of independently adjustable units the container body end passed on along the edge of the closure skirt and the edge portion of the skirt passed into position against the inner face of said container body to form a fivefold seam.

10. A device according to claim 9 on which the heads are provided with opposed members having like grooves therein, the first spinning head forming a substantially close curl.

11. In a machine for securing closures in the ends of cylindrical containers, a spindle having a plurality of heads, means to intermittently rotate said spindle to bring each head into an operative position, a holder in each head to firmly grasp a container body entered therein, elastic means to apply an internal band of adhesive a predetermined distance from the open end of the container body, means to expand said elastic means, and means to interengage the walls of the container body and closure.

12. In a machine for securing closures in the bottom of cylindrical containers, a spindle having a plurality of heads, means to intermittently rotate said spindle to bring each head into an operative position, each head having a holder to receive and firmly retain a container body therein, an expandible soft roll to deposit a band of adhesive material on the interior of the body, and means to insert a closure having an annular outwardly extending skirt attached by the adhesive material.

13. In a machine for securing closures in the bottoms of cylindrical containers, a spindle having a plurality of radial heads, means to intermittently rotate said spindle to bring each head into an operative position, means in each head to firmly grasp a container body entered therein, dilatible means to apply an internal band of adhesive a predetermined distance from the open bottom end of the container body, and means for inserting a closure therewithin, said closure having an annular skirt portion close fitting the body and fixedly engaged therein by said adhesive band.

14. In a machine for securing closures in the ends of cylindrical containers, a spindle having a plurality of radial heads, means to intermittently rotate said spindle to bring each head into an operative position, a holder to receive the body of a container in each head, means to close the holder on the body, an arbor entrable within the body to locate a bottom closure element therein, means to expand and contract said arbor, said arbor expansible to the full inner diameter of the container body, and means to eject the container from the head upon completion of work thereon.

15. In a machine for securing closures in the ends of cylindrical containers, a spindle having a holder to receive and firmly retain a container body therein, an elastic roll to deposit a band

of adhesive material on the interior of the body, means to expand said roll, and means to insert a closure having an annular outwardly extending skirt to become attached by the adhesive material.

16. In a machine for securing closures in the ends of cylindrical containers, a spindle having a plurality of heads, means to intermittently bring each head into an operative position, each head having a holder to receive and securely retain a container body therein, an elastic roll to deposit a band of adhesive material on the interior of the body in a predetermined position, means to expand said roll means to spread the adhesive, and means to insert a closure having an annular outwardly extending skirt to become attached by the adhesive material.

17. In a machine for making paper closures for circular paper containers, a magazine to contain a stack of paper discs, a pair of dies respectively inner and outer, said outer die equal in its inner diameter to the inner diameter of said container and said inner die a straight cylinder of corresponding diameter less a double thickness of said disc, the faces of both dies flat except for a shallow marginal elevation on the inner die and corresponding depression in the outer die, guide stops to adjust the disc centrally with respect to said dies, feed means to transfer the disc from said magazine to said stops when discharged from the magazine, means to actuate said dies in unison axially whereby the marginal portion of the disc is formed into an annular skirt having an offset ring interjacent thereto completing the container closure, and means to release the closure from said dies.

18. In the process of securing closures in cylindrical paper containers, the steps which consist of forcing a preformed closure having rigid disc and resilient skirt portions a predetermined distance through the bottom into and past the lower end of the container body, limitedly curling the edge of the container to a small radius to engage the edge of the skirt portion of said closure, and recurling the combined edges of the container and skirt to form an inreaching beaded seam.

19. In the process of bottoming cylindrical paper containers, the steps which consist of entering the lower portion of the container body into a rigid unyielding holder, applying a band of adhesive material within said body at a predetermined distance from its end, removing any strings of excess material therefrom, forcibly entering a tight fitting preformed closure having disc and skirt portions, said skirt portion outermost, spinning the lower edge of said body inwardly and upwardly to form an initial close curl adjacent the edge of said skirt portion, recurling the combined edges of said body and skirt to form an internal annular bead adjacent said disc portion, and coincidentally exerting pressure on the inner and outer sides of said bead to cause a coalesced seam.

20. In a machine for securing closures in the ends of cylindrical containers, a spindle having a plurality of heads, means to intermittently rotate said spindle to bring each head into an operative position, a holder in each head to firmly grasp a container body a dilatible roll to apply an internal band of adhesive a predetermined distance from the open end of the container body, and means to interengage the walls of the container body and closure.

IRVING F. MANDELL.