

(12) INTERNATIONAL APPLICATION PUBLISHED UNDER THE PATENT COOPERATION TREATY (PCT)

(19) World Intellectual Property Organization
International Bureau



(43) International Publication Date
12 September 2003 (12.09.2003)

PCT

(10) International Publication Number
WO 03/074642 A1

- (51) International Patent Classification⁷: **C11C 5/00**
- (21) International Application Number: PCT/GB03/00840
- (22) International Filing Date: 28 February 2003 (28.02.2003)
- (25) Filing Language: English
- (26) Publication Language: English
- (30) Priority Data:
0204803.1 1 March 2002 (01.03.2002) GB
- (71) Applicant (for all designated States except US): **INOVAIR LIMITED** [GB/GB]; 58 Michelham Gardens, Strawberry Hill, London TW1 4SB (GB).

(81) Designated States (national): AE, AG, AL, AM, AT, AU, AZ, BA, BB, BG, BR, BY, BZ, CA, CH, CN, CO, CR, CU, CZ, DE, DK, DM, DZ, EC, EE, ES, FI, GB, GD, GE, GH, GM, HR, HU, ID, IL, IN, IS, JP, KE, KG, KP, KR, KZ, LC, LK, LR, LS, LT, LU, LV, MA, MD, MG, MK, MN, MW, MX, MZ, NO, NZ, OM, PH, PL, PT, RO, RU, SC, SD, SE, SG, SK, SL, TJ, TM, TN, TR, TT, TZ, UA, UG, US, UZ, VC, VN, YU, ZA, ZM, ZW.

(84) Designated States (regional): ARIPO patent (GH, GM, KE, LS, MW, MZ, SD, SL, SZ, TZ, UG, ZM, ZW), Eurasian patent (AM, AZ, BY, KG, KZ, MD, RU, TJ, TM), European patent (AT, BE, BG, CH, CY, CZ, DE, DK, EE, ES, FI, FR, GB, GR, HU, IE, IT, LU, MC, NL, PT, SE, SI, SK, TR), OAPI patent (BF, BJ, CF, CG, CI, CM, GA, GN, GQ, GW, ML, MR, NE, SN, TD, TG).

Published:
— with international search report
— before the expiration of the time limit for amending the claims and to be republished in the event of receipt of amendments

For two-letter codes and other abbreviations, refer to the "Guidance Notes on Codes and Abbreviations" appearing at the beginning of each regular issue of the PCT Gazette.

(54) Title: WAX AND CANDLE COMPOSITIONS

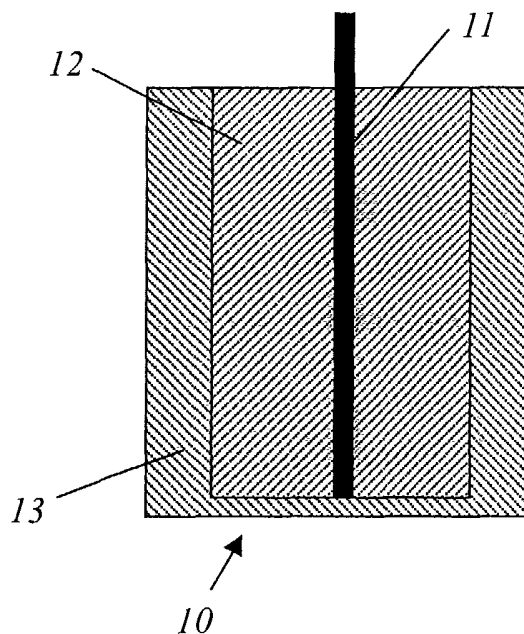

(57) Abstract: There is described a candle comprising at least two distinct phases characterised in that at least one of the phases comprises between 0.0001 % w/w and 99 % w/w of an active volatile material. The active volatile material is selected from an insecticide, an insect repellent, an insect attractant, a fragrance, a deodorising and an anti-bacterial agent, or any combination thereof.



WO 03/074642 A1

WAX AND CANDLE COMPOSITIONS

Background of the Invention

This invention generally relates to the dispensing of volatile material, e.g. a
5 fragrance, from a candle product. More specifically this invention relates to a free-
standing candle comprising an outer, volatile material containing shell, an inner core
and wick.

A typical candle is formed of a solid, or semi-solid, body of wax such as paraffin
10 wax or beeswax that contains an axially embedded combustible wick. When the
wick of the candle is lit the heat that is generated melts the solid wax. The resulting
liquid wax rises up the wick through capillary action and is combusted. More
recently transparent and translucent candles have been developed in which the body
of the candle comprises a solvent blended with a polymeric material to form a gel.
15 For example United States Patent number 6,111,055 describes a gel candle
composition comprising an ester-terminated dimer acid-based polyamide blended
with a solvent. In this case the heat generated when the wick is lit is sufficient to
melt the gel composition, and the resulting liquid is transported to the top of the wick
by capillary action and is combusted.

20 Depending on the composition, the candle may be formed into a free-standing pillar,
or may be better suited to being placed in a container.

Candles have also been developed that incorporate a perfume base in the wax or gel
25 body. As the wax is melted in a lighted candle, there is a release of fragrance from
the molten wax pool. Furthermore, the incorporated fragrance can slowly evaporate
from the surface of the solid wax body of an unlit candle, thereby providing a low
level of fragrance to the surrounding atmosphere.

30 Conventional fragrance candles have drawbacks because of cost and other
considerations. Much of the fragrance incorporated into a conventional fragrance
candle is drawn up the wick and combusted during candle burning, leaving only a

candle is drawn up the wick and combusted during candle burning, leaving only a relatively small amount of fragrance to evaporate from the molten wax pool and to freshen the surrounding atmosphere. Further, the migration of incorporated fragrance through the solid wax body of an unlit candle is relatively slow and the level of fragrance released is lower than desired. Increasing the amount of fragrance incorporated into the candle to a level sufficient to freshen the surrounding atmosphere makes the candle tacky or oily and deprives the candle of sufficient structural properties to enable it to resist damage and stand freely. Conventional fragrance candles are generally therefore protected and supported by a rigid, non-flammable container, typically made of for example glass or ceramic.

US Patent No. 4,568,270 describes a fragranced free standing candle which comprises an inner fragranced core comprising from 5 to 12% by weight of fragrance oil and an outer shell comprising a high melting paraffin/wax mixture. The outer core may also be fragranced and the examples, e.g. examples 16 to 30 suggest that the amount of fragrance oil in the outer shell may be from 5 to 12% by weight. However, such candles still suffer from the disadvantage that approximately 50% by weight of the fragrance oil is still present in the inner core and this may be lost by, e.g. combustion.

Furthermore, attempts to incorporate a high fragrance loading into a wax candle may have a deleterious effect on the burn performance of the candle.

There is therefore continuing interest in the development of improved fragrance and other types of candle products, for example, insecticidal candles, deodorising candles and antibacterial candles, which overcome or mitigate the disadvantages of prior art candles.

Description of the Invention

It is an object of this invention to remedy the problems of conventional candles outlined above. In particular an object of the invention is to provide a free-standing

wax air freshener and/or a free standing air freshener candle product, or other such candle products comprising a volatile material, which releases a suitable level of the volatile material into the atmosphere when unlit, and that will release an increased level of the volatile material to the atmosphere when lit.

5

It is another object of this invention to provide a candle comprising a wax-like composition which has a surprisingly high content of volatile material.

Other objects and advantages of the present invention shall become apparent from the accompanying descriptions and drawings.

10

According to a first aspect of the invention we provide a candle comprising at least two distinct phases characterised in that at least one of the phases comprises from 0.0001 % w/w to 99 % w/w of an active volatile material.

15

In certain embodiments the phases of the candle may comprise, for example, first and second layers. Although it will be understood that a candle of the invention may comprise more than two layers. In an alternative aspect of the inventions the phases or layers may comprise a core, e.g. a cylindrical core and an outer shell. However, again it will be understood that each of the core and outer shell may themselves comprise a plurality of layers.

20

The candle of the invention may comprise at least 5% w/w of an active volatile material, preferably 10% w/w of an active volatile material and especially at least 15% w/w and less than 99.99% of an active volatile material.

25

A candle according to claim 1 characterised in that the active volatile material is selected from an insecticide, an insect repellent, an insect attractant, a fragrance, a deodorising agent and an anti-bacterial agent, or any combination thereof. Alternatively, the active volatile material is selected from an insecticide, an insect repellent, a deodorant and an anti-bacterial agent, or any combination thereof. In a

30

particular embodiment of the invention the active volatile material may be a fragrance.

5 In a preferred aspect of the invention, at least one of the phases of the candle may comprise from 1 % w/w to 99 % w/w of an active volatile material, preferably from 12 % w/w to 99 % w/w of an active volatile material, more preferably from 15% to 99% w/w of an active volatile material and especially from 20 % w/w to 70% w/w of an active volatile material.

10 In a preferred aspect of the invention the wax air freshener may be in the form of a candle. Thus, according to a further aspect of the invention we provide a free-standing fragranced candle comprising a wax incorporating a perfume base and a wick characterised in that the fragrance content of the wax is greater than 15% by weight.

15

In a further embodiment the candle of the invention may comprise an outer shell and an inner core. Thus, for example the candle may comprise an outer shell with a fragrance content of greater than 15%. The inner core may comprise a fragrance content the same as or preferentially lower than that of the outer shell.

20

In accordance with this aspect of the invention we provide a free-standing fragranced candle comprising an outer shell incorporating a perfume base, an inner core and a wick characterised in that the fragrance content of the outer shell is greater than 15% by weight.

25

In a preferred embodiment of the invention the candle as hereinbefore described comprises an outer shell characterised in that the perfume base content of the outer shell is from 15 to 70% by weight.

In a further preferred embodiment of the invention the candle may comprise an outer shell having a higher melting point than the inner core. The outer shell as hereinbefore described may include a layer over the top of the candle.

5 The outer shell may be continuous or discontinuous and / or the outer shell may cover all or part of the faces/sides/surfaces of the core.

In the candle of the invention at least one of the phases may act as a bonding, sealing, separating, barrier, supporting or coating agent or a combination thereof on the other phase.

10

Alternatively, at least one of the phases may comprise a non-melting wax, stone, metal, plastic, or ceramic or a mixture thereof and from 0.0001 % w/w to 99 % w/w of an active volatile material selected from an insecticide, insect repellent, insect attractant, a fragrance, deodorising or anti-bacterial agent.

15

At least one of the phases may comprise a glass and from 7 % w/w to 99 % w/w of an active volatile material whereby the active volatile material is a fragrance or from 0.0001 % w/w to 99 % w/w of an active volatile material whereby the active volatile material is selected from an insecticide, insect repellent, insect attractant, deodorising or anti-bacterial agent

20

Alternatively, at least one of the phases may comprise any combination from a glass and from 7 % w/w to 99 % w/w of an active volatile material whereby the active volatile material is a fragrance or from 0.0001 % w/w to 99 % w/w of an active volatile material whereby the active volatile material is selected from an insecticide, insect repellent, insect attractant, deodorising or anti-bacterial agent and a non-melting wax, stone, metal, plastic, or ceramic or a mixture thereof and from 0.0001 % w/w to 99 % w/w of an active volatile material selected from an insecticide, insect repellent, insect attractant, a fragrance, deodorising or anti-bacterial agent.

25
30

In an alternative aspect of the invention we provide a candle which is a free-standing candle or a candle in an open or closed container.

When the candle comprises layers, it may be such that, in normal use at least one of the phases is horizontally oriented. Alternatively, at least one of the phases may be vertically oriented.

The phases have different melting rates.

In a further aspect of the invention we provide a device comprising a candle as hereinbefore described wherein the device is adapted to be used as an air freshener, insecticide, insect repellent, insect attractant, deodorising and/or anti-bacterial device characterised in that it does not comprise a candle wick.

Alternatively, the device may comprise an air freshener, insect or pest control product, odour neutraliser, deodoriser or anti-bacterial device.

In a further embodiment one phase of the candle may comprise a liquid at room temperature. Alternatively, at least one phase of the candle may comprise a liquid fuel.

The inner core is formed of a solid body of wax, such as paraffin wax or beeswax. Optionally the inner core may contain up to 10 weight percent of a perfume base. The inner core may be coated with between about 0.2-4.0mm of a fragranced outer shell.

Preferably, the fragranced outer shell may contain between about 30-70 weight percent of a perfume base and a carrier therefor, and is not tacky or oily at ambient temperature more preferably 40 to 60% by weight.

30

The unusually high concentration of perfume base in the outer shell is sufficient to ensure a suitable release of fragrance to the surrounding atmosphere when the candle is unlit. Further, concentrating the perfume base in the thin outer shell facilitates migration to the surface of the candle body. When the wick of the candle is lit the heat generated is sufficient to melt the inner core, forming a molten pool within the shell. If perfume base is incorporated in to the inner core then some will evaporate from the molten pool to freshen the surrounding atmosphere, though much will be drawn up the wick and combusted as previously described. The perfume base incorporated in the outer shell is distant from the wick and is therefore less likely to be combusted. The heat generated by the flame and heat transfer from the molten pool is sufficient to warm the outer shell and enhance evaporation of perfume base therefrom, thereby providing a significant release of fragrance to the surrounding atmosphere.

Candles of this aspect of the invention, comprising an inner core and an outer fragranced shell are especially advantageous in that, *inter alia*, they provide a candle which possess a significantly improved burn performance.

The shell is preferably formed from a mixture comprising (a) between about 30-70 weight percent of a perfume base, (b) between about 20-70 weight percent of a linear alpha olefin and (c) optionally up to 50 weight percent of a suitable solvent. More preferably the shell comprises between about 40-60 weight percent of a linear alpha olefin and between about 40-60 weight percent of a perfume base.

However, in a further alternative a second outer shell may be included in the candle wherein the second outer shell comprises an unfragranced or fragranced layer. Thus, the candle may comprise, for example, an inner unfragranced core, a highly fragranced intermediate layer and then a further unfragranced outer layer. Such a candle is advantageous in that the fragrance is only released when the wax melts.

The shell may be made up a multitude/plurality of layers each of which are fragranced or unfragranced.

In a yet further alternative the inner core may be perfume free. Such a perfume free inner core candle may be advantageous in that it will have a superior burn performance over a perfumed core candle, especially when this contains a high dosage of fragrance. This would make the candle as well cheaper without sacrificing fragranc

5 ing performance.

In a further embodiment of the invention the inner core and/or the outer shell of the candle may comprise a transparent material, such as those described in:

10

- a) US Patent No. 6,268,466 to Arizona Chemical which relates to amide terminated polyamides.
- b) US Patents Nos. 6,111,055, 5,998,570 and 5,783,657 to Union Camp which describe ester terminated polyamide.

15

In such a candle any conventionally known transparent materials or combinations thereof or with wax may be used.

According to a further aspect of the invention we provide a process for the preparation of a candle as hereinbefore described characterised in that the process comprises a method selected from one or more of moulding, dipping, compressing, extruding and the like.

20

The process of the invention may also comprise coating a conventional candle.

25

In an especially preferred aspect of the invention the core may be coated in a paraffin wax, e.g. by dipping, before being coated with the outer layer. Such a method of manufacturing is especially advantageous in that the use of a paraffin wax intermediate layer creates an improved bond between the core and the outer layer.

30 Thus, such candles are novel *per se* and therefore according to a yet further aspect of the invention we provide a candle comprising at least one core and at least one outer

shell as hereinbefore described and including an intermediate layer, e.g. an intermediate paraffin wax layer.

In a yet further alternative the fragrance may be encapsulated inside the wax.

5

According to a yet further aspect of the invention we provide a candle lantern comprising a candle as hereinbefore described.

The waxes of the invention may be suitable for use as, *inter alia*, conventional air fresheners. However, one or more conventionally known insecticide materials may be included in the wax formulation (both in the shell or / and in the core). Thus such wax formulations may be suitable for use as an insecticide/deodoriser.

10

Brief Description of the Drawings

15

A better understanding of the objects, features and advantages of the present invention can be gained from the following detailed description of the preferred embodiments in conjunction with the appended drawings, wherein:

FIG. 1 is a plan view of an embodiment of a fragranced candle according to the invention;

20

FIG. 2 is a cross-sectional view taken along the line 1-1 of FIG. 1;

FIG. 3 is a plan view of a further embodiment of a fragranced candle according to the invention;

FIG. 4 is a cross-sectional view taken along the line 2-2 of FIG. 3;

FIG. 5 is a cross-sectional plan view of a multilayered candle of the invention;

25

FIG. 6 is a vertical cross-section of a candle of FIG. 5;

FIG. 7 is a cross-sectional plan view of a square multilayered candle of the invention;

30

FIG. 8 is a vertical cross-section of a candle of FIG. 7;

FIG. 9 is a vertical cross-section of a candle of the invention comprising multilayers at one end;

FIG. 10 is a cross-sectional plan view of a shell candle comprising a plurality of discontinuous layers;

FIG. 11 is a vertical cross-section of a shell candle comprising a plurality of discontinuous layers;

5 FIG. 12 is a cross-sectional plan view of a shell candle comprising a plurality of discontinuous layers;

FIG. 13 is a vertical cross-section of a shell candle comprising a plurality of discontinuous layers; and

10 FIG. 14 is a vertical cross-section of a shell candle comprising a plurality of discontinuous multilayers at one end.

Preferred Embodiments of the Invention

FIGS. 1 and 2 show a free-standing fragrance candle 10 according to the invention.
15 The candle 10 comprises a wick 11, an inner core 12, and an outer shell 13.

The core 12 can be produced by employing conventional candle making methods such as moulding, dipping, compressing, extruding and the like. The core 12 is formed of a material selected from the group consisting essentially of paraffin,
20 paraffin wax, beeswax, montan wax, carnauba wax, microcrystalline wax, fatty alcohols, fatty acids, fatty esters, natural and synthetic resins, and mixtures thereof. Optionally, but not necessarily, the core 12 can also contain perfume base.

The shell 13 is preferably formed from a mixture comprising (a) between about 30-70
25 weight percent of a perfume base, (b) between about 20-70 weight percent of a linear alpha olefin and (c) optionally up to 50 weight percent of a suitable solvent. More preferably the shell 13 comprises between about 40-60 weight percent of a linear alpha olefin and between about 40-60 weight percent of a perfume base.

30 Among the different qualities of linear alpha olefins available, particularly good results have been obtained by using LAO C30+ (available from Aiglon S.A.).

As a perfume base there is used in the shell 13, and optionally in the core 12, any of the compositions currently used in perfumery. These can be discreet chemicals, more often however they are mixtures of volatile liquid and/or solid ingredients of natural
5 or synthetic origin. The nature of these ingredients can be found in specialised books of perfumery, e.g. in S. Artander (Perfume and Flavor Chemicals, Montclair N.J., USA 1969). Suitable perfume bases are available commercially from a number of fragrance suppliers.

10 Optionally the shell 13 can be formed from a mixture of a perfume base and materials selected from the group consisting of paraffin, paraffin wax, beeswax, montan wax, carnauba wax, microcrystalline wax, fatty alcohols, fatty acids, fatty esters, natural and synthetic resins, and mixtures thereof. In such instances the maximum amount of perfume base incorporated in the shell is limited to
15 approximately 50 weight percent, as inclusion levels above this amount make the candle tacky or oily and generally disagreeable to the touch.

A fragrance candle according to the present invention preferably comprises a number of additional features. Thus while a plurality of wicks each equidistant from the
20 candle axis can be employed, it is usual for there to be a single wick 11 which extends along the candle axis.

The candle 10 can have any shape that a conventional pillar candle can have. In
FIGS. 1 and 2 the core 12 and shell 13 are cylindrical.

25

In FIGS. 3 and 4 the core 22 and shell 23 are square in a cross section taken in a plane normal to the wick 21.

Example 1

30 A core was formed using a commercially available unfragranced cylindrical pillar candle with a single wick extending along the candle axis. The core had a diameter

of approximately 50mm, a height of approximately 105mm and a total mass of 172.3g.

5 A shell composition was prepared by heating 150.0g of a perfume base (lavender scent) and 100.0g of LAO C30+ (available from Aiglon S.A.) in a sealed 500ml glass powder jar to 90°C in a water bath, whereupon the linear alpha olefin dissolved in the perfume base. The mixture was agitated until completely homogeneous and then cooled to 75°C.

10 The core was dipped into the molten shell composition, removed and allowed to cool. This dipping and cooling process was repeated until the total mass of the candle had increased to 189.0g. The shell thus had a total mass of about 16.7g, a thickness of about 1mm and contained approximately 10.0g of the perfume base.

15 The free standing pillar candle thus produced was not tacky or oily, and provided a suitable amount of fragrance to freshen the surrounding air when unlit.

20 Once lit the fragranced shell, being more distant from the candle flame melted more slowly than the core and formed a rim, which retained the molten pool formed as the candle burned. The shell surrounding the molten pool was warmed to a temperature above ambient, facilitating additional release of perfume base to the surrounding atmosphere.

Example 2

25

4.0g of a perfume base (lavender scent) was mixed with 196.0g of a molten commercially available paraffin wax blend, and 150.0g of the resulting mixture poured into a cylindrical candle mould and allowed to cool to ambient temperature. A fragranced core, with an axially embedded wick, was thus produced. The core had
30 a diameter of approximately 43mm and a height of approximately 115mm.

A shell composition was prepared by heating 125.0g of a perfume base (lavender scent) and 125.0g of LAO C30+ (available from Aiglon S.A.) in a sealed 500ml glass powder jar to 90°C in a water bath, whereupon the linear alpha olefin dissolved in the perfume base. The mixture was agitated until completely homogeneous and then
5 cooled to 75°C.

The core was dipped into the molten shell composition, removed and allowed to cool. This dipping and cooling process was repeated until the total mass of the candle had increased by 14.0g. The shell had a thickness of about 1mm and
10 contained approximately 7.0g of the perfume base.

The free standing pillar candle thus produced was not tacky or oily, and provided a suitable amount of fragrance to freshen the surrounding air when unlit.

15 Once lit the fragranced shell, being more distant from the candle flame melted more slowly than the core and formed a rim, which retained the molten pool formed as the candle burned. The shell surrounding the molten pool was warmed to a temperature above ambient, facilitating additional release of perfume base to the surrounding atmosphere. Additional fragrance was released from the molten pool as in a
20 conventional fragrance candle.

25

30

35

40

45

CLAIMS

1. A candle comprising at least two distinct phases characterised in that at least one of the phases comprises from 0.0001 % w/w to 99 % w/w of an active volatile material.
2. A candle according to claim 1 characterised in that the active volatile material is selected from an insecticide, an insect repellent, an insect attractant, a fragrance, a deodorising agent and an anti-bacterial agent, or any combination thereof.
3. A candle according to claim 2 characterised in that the active volatile material is selected from an insecticide, an insect repellent, an insect attractant, a deodorising agent and an anti-bacterial agent, or any combination thereof.
4. A candle according to claim 1 characterised in that at least one of the phases comprises from 1 % w/w to 99 % w/w of an active volatile material.
5. A candle according to claim 1 characterised in that at least one of the phases comprises from 12 % w/w to 99 % w/w of an active volatile material.
6. A candle according to claim 5 characterised in that at least one of the phases comprises from 15% to 99% w/w of an active volatile material.
7. A candle according to claim 6 characterised in that at least one of the phases comprises from 20 % w/w to 70% w/w of an active volatile material.
8. A candle according to claim 5 characterised in that the active volatile material is a fragrance, deodorising agent, insect repellent or anti-bacterial agent
9. A candle according to claim 5 characterised in that the active volatile material is a fragrance.

10. A candle according to claim 1 characterised in that the two phases comprise a first layer and at least a second layer which is an outer layer wherein, the outer layer comprises from 0.0001 % w/w to 99 % w/w of an active volatile material.
- 5 11. A candle according to claim 10 characterised in that the candle comprises a single outer layer.
12. A candle according to claim 10 characterised in that the first layer comprises a core and the outer layer is a shell.
- 10 13. A candle according to claim 12 characterised in that the core comprises from 0 to 99% w/w of an active volatile material
14. A candle according to claim 13 is characterised in that the active volatile
15 material is selected from an insecticide, an insect repellent, an insect attractant, a deodorising agent and an anti-bacterial agent.
15. A candle according to claim 13 characterised in that the core comprises from 0.0001 % to 99 % w/w of an active volatile material.
- 20 16. A candle according to claim 15 characterised in that the active volatile material is selected from a fragrance, an insecticide, an insect repellent, an insect attractant, a deodorising agent and an anti-bacterial agent.
- 25 17. A candle according to claim 10 characterised in that the core comprises from 15% w/w to 99 % w/w of an active volatile material and the active volatile material is a fragrance.
- 30 18. A candle according to claim 10 characterised in that the core comprises from 0 to 99 % w/w of a volatile materials selected from an insecticide, an insect repellent, an insect attractant, a deodorising agent and an antibacterial agent, and / or

from 15 % w/w to 99% w/w of one or more active volatile materials wherein the active volatile material is a fragrance.

19. A candle according to claim 1 characterised in that one or both of the phases
5 comprise of a single layer or a plurality of layers and at least one of the layers comprises from 0.0001% w/w to 99% w/w of an active volatile material, selected from an insecticide, an insect repellent, an insect attractant, , a deodorising agent and an anti-bacterial agent.

10 20. A candle according to claim 1 characterised in that one or both of the phases comprise of a single layer or a plurality of layers and at least one of the layers comprises, from 7 % w/w to 99 % w/w of an active volatile material wherein the active volatile material is selected from a fragrance, deodorising agent, insect repellent or anti-bacterial agent.

15 21. A candle according to claim 1 characterised in that one or both phases comprise of a single layer or a plurality of layers and at least one of the layers comprises a combination from 0.0001% w/w to 99% w/w of one or more volatile materials selected from an insecticide, an insect repellent, an insect attractant, a deodorising agent and an antibacterial agent, and / or from 7 % w/w to 99% w/w of one or more
20 active volatile materials wherein the active volatile material is a fragrance.

22. A candle according to claim 1 characterised in that at least one of the phases comprises an olefin.

25 23. A candle according to claim 1 characterised in that at least one of the phases comprises a material selected from,
a linear α -olefin or a mixture of linear α -olefins,
a linear α -olefin or a mixture of linear α -olefins, wherein at least one of the linear
30 alpha olefins is at least a C30 linear α -olefin,

- a linear α -olefin or a mixture of linear α -olefins, wherein at least one of the linear α -olefins is LAO C30+,
Sylvaclear (ATPA) or a mixture of amide terminated polyamides,
Uniclear (ETPA) or a mixture of ester terminated polyamides,
- 5 another material, selected from a suitable solvent, paraffin was, beeswax, stearine, montan wax, carnauba wax, microcrystalline wax, an elastomer, fatty alcohols, fatty acids, fatty esters, natural and synthetic resins, another materials, or any combination thereof.
- 10 24. A candle according to claim 1 characterised in that the two phases comprise a first phase which is an inner core and a second phase which is at least one outer layer wherein at least one of phases comprises from 20 to 70 % by weight of a linear α -olefin or a mixture of linear α -olefins.
- 15 25. A candle according to claim 24 characterised in that the at least one phase comprises from 40 to 60 % by weight of a linear α -olefin or a mixture of linear α -olefins.
26. A candle according to claim 23 characterised in that at least of the phases
20 comprises from about 40 to 60 % w/w of a linear alpha olefin and from about 40 to 60 % w/w of a fragrance.
27. A candle according to claim 22 characterised in that the outer layer comprises
a mixture of linear α -olefins.
- 25 28. A candle according to claim 1 characterised in that the at least one phase
comprises up to 50 weight percent of a suitable solvent
29. A candle according to claim 1 characterised in that the candle comprises at
30 least two volatile active materials in one or more phases which may be the same or

different, each of which may be selected from an insecticide, an insect repellent, an insect attractant, a fragrance, a deodorising agent or an anti-bacterial agent.

30. A candle according to claims 1 characterised in that at least one of the phases
5 is discontinuous.

31. A candle according to claims 1 characterised in that at least one of the phases is unconnected with the other phase and is connected to an element of the candle.

10 32. A candle according to claim 1 in that at least one of the phases does not comprise an active volatile material.

33. A candle according to claim 1 characterised in that at least one of the phases acts as a bonding, sealing, separating, barrier, supporting or coating agent or a
15 combination thereof on the other phase.

34. A candle according to claim 1 characterised in that at least one of the phases comprises a non-melting wax, stone, metal, plastic, or ceramic or a mixture thereof and from 0.0001 % w/w to 99 % w/w of an active volatile material selected from an
20 insecticide, insect repellent, insect attractant, a fragrance, deodorising or anti-bacterial agent

35. A candle according to claim 1 characterised in that at least one of the phases comprises a glass and from 7 % w/w to 99 % w/w of an active volatile material
25 whereby the active volatile material is a fragrance or from from 0.0001 % w/w to 99 % w/w of an active volatile material whereby the active volatile material is selected from an insecticide, insect repellent, insect attractant, deodorising or anti-bacterial agent

30 36. A candle according to claim 1 characterised in that at least one of the phases comprises any combination from a glass and from 7 % w/w to 99 % w/w of an active

volatile material whereby the active volatile material is a fragrance or from 0.0001 % w/w to 99 % w/w of an active volatile material whereby the active volatile material is selected from an insecticide, insect repellent, insect attractant, deodorising or anti-bacterial agent and a non-melting wax, stone, metal, plastic, or ceramic or a mixture thereof and from 0.0001 % w/w to 99 % w/w of an active volatile material selected from an insecticide, insect repellent, insect attractant, a fragrance, deodorising or anti-bacterial agent.

37. A candle according to claim 1 characterised in that it is either a free-standing candle or a candle in an open or closed container.

38. A candle according to claim 1 characterised in that in normal use at least one of the phases is horizontally oriented.

39. A candle according to claim 1 characterised in that in normal use at least one of the phases is vertically oriented.

40. A candle according to claims 1 characterised in that the phases have different melting rates.

41. A candle according to claim 1 characterised in that the candle comprises a plurality of wicks.

42. A device comprising a candle according to claim 1 adapted to be used as an airfreshener, insecticide, insect repellent, insect attractant, deodorising and/or anti-bacterial device characterised in it does not comprise a candle wick.

43. A device according to claim 42 characterised in that the device comprises an air freshener, insect or pest control product, odour neutralizer, deodoriser or anti-bacterial device.

44. A candle according to claim 1 characterised in that one phase comprises a liquid at room temperature.
45. A candle according to claims 44 characterised in that at least one phase
5 comprises a liquid fuel.
46. A candle according to claim 45 characterised in that the liquid comprises an oil, an alcohol or other fuel or mixtures thereof.
- 10 47. A candle according to claim 1 characterised in that at least one of the phases comprises a transparent material.
48. A candle according to claim 1 characterised in that the active volatile material is encapsulated inside one of the phases.
15
49. A process for the preparation of a candle according to claim 1 characterised in that the process comprises a method selected from one or more of moulding, dipping, compressing, extruding and the like.
- 20 50. A process according to claim 49 characterised in that the process comprises coating a conventional candle
51. A candle according to claim 1 characterised in that the candle has an improved burn performance
25

30

35

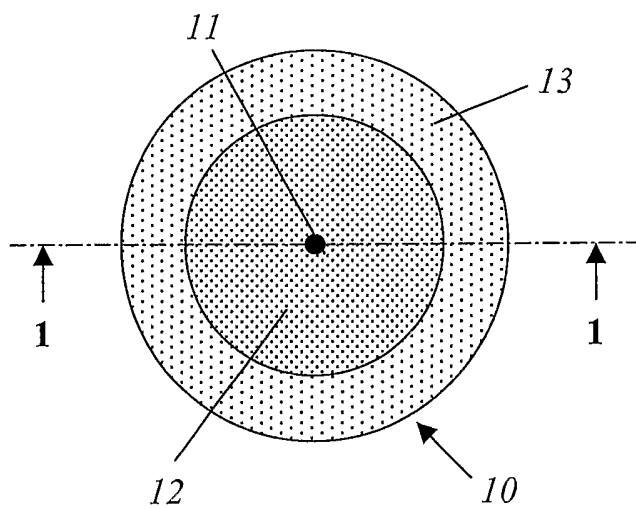

FIG. 1

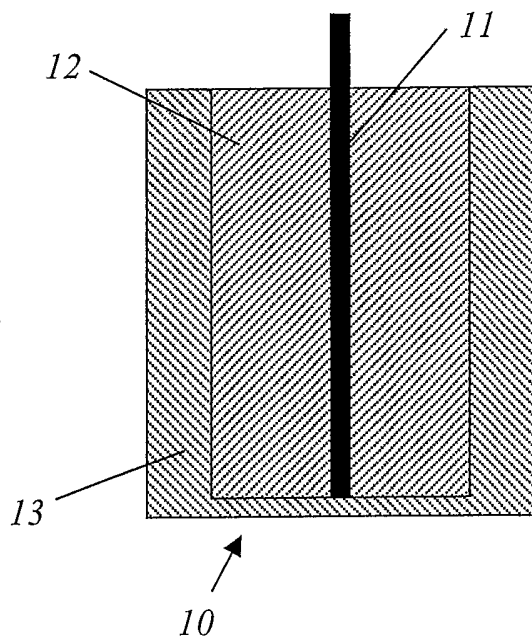

FIG. 2

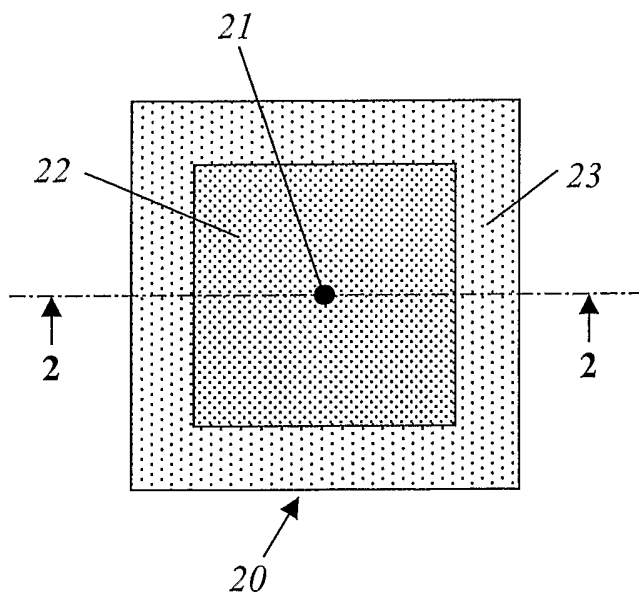

FIG. 3

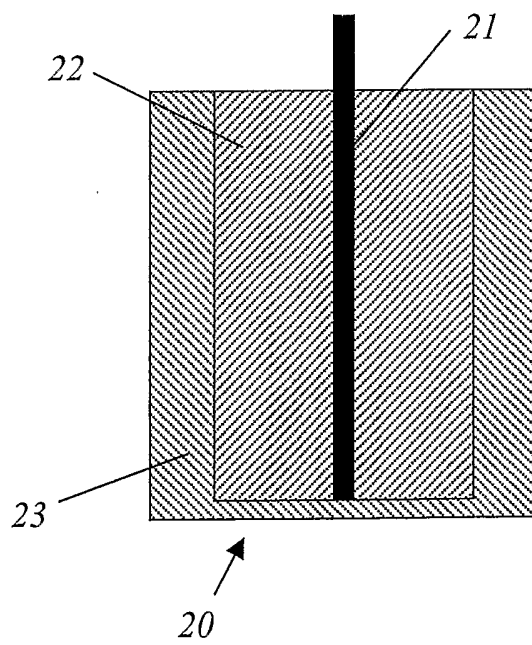

FIG. 4

FIG. 5

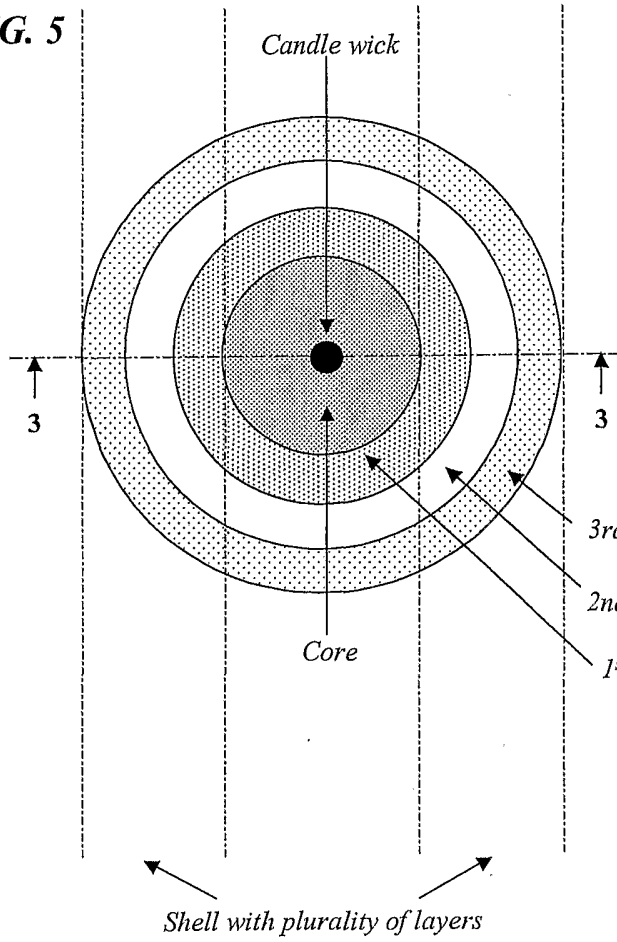

FIG. 6

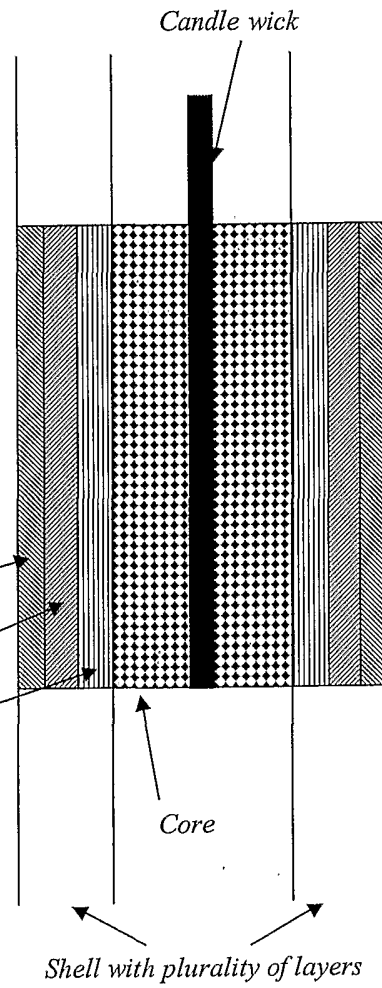

FIG. 7

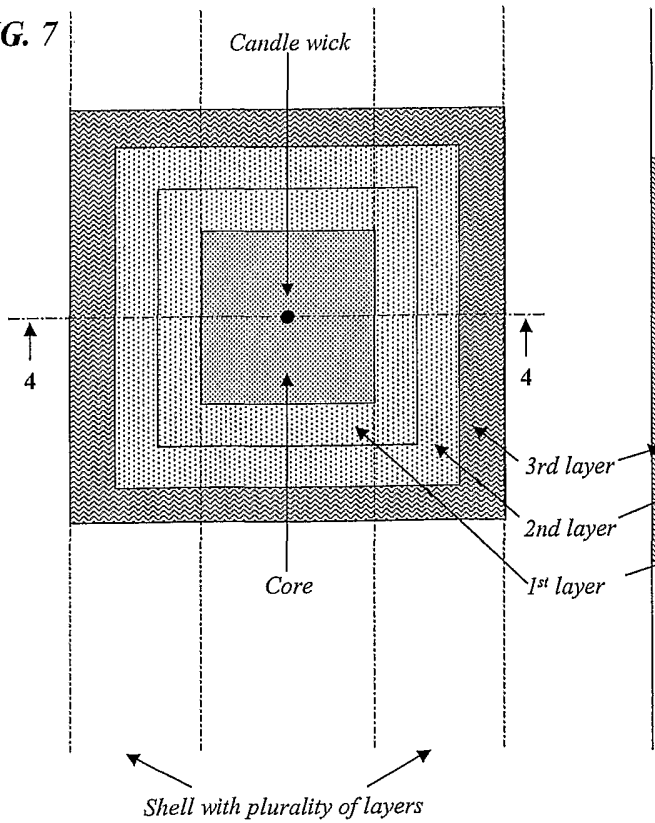

FIG. 8

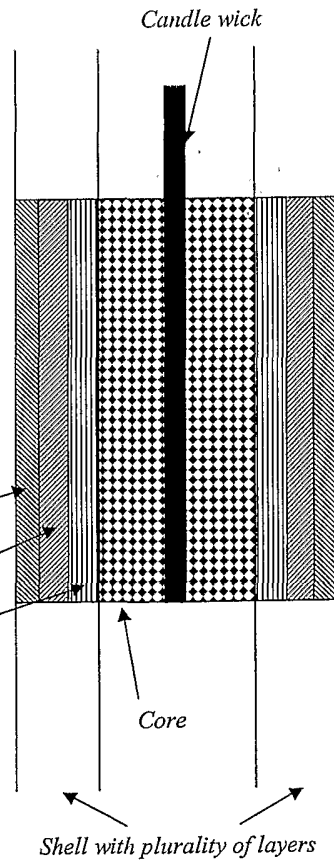

FIG. 9

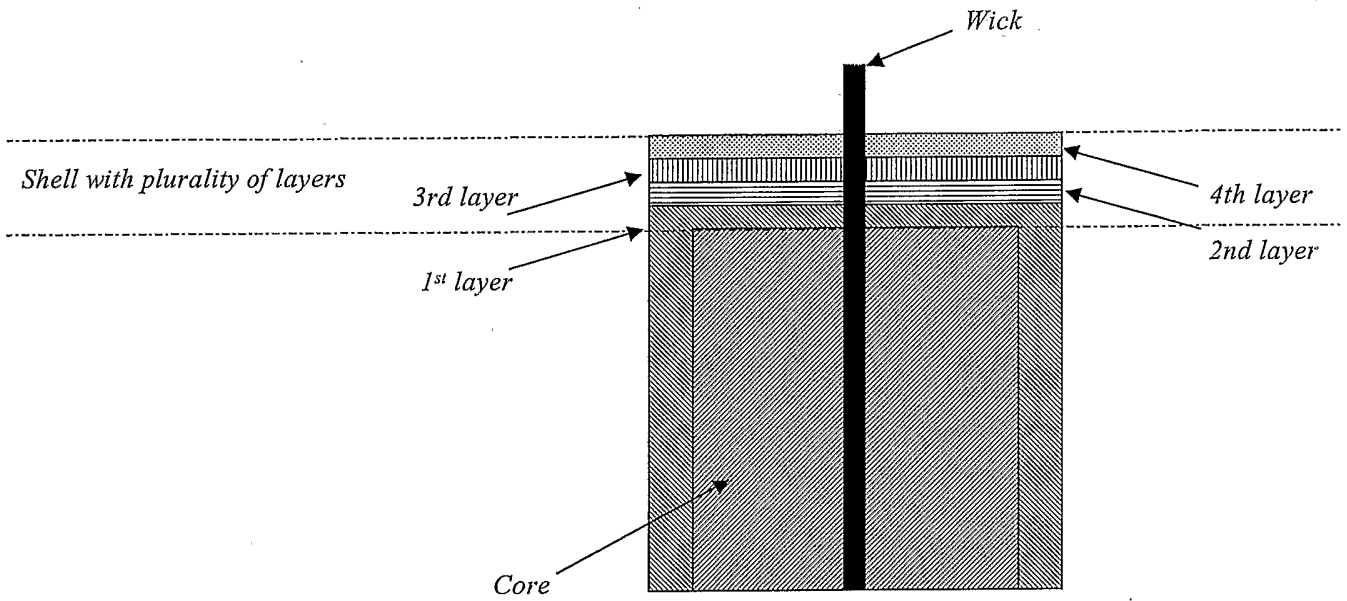

FIG. 10

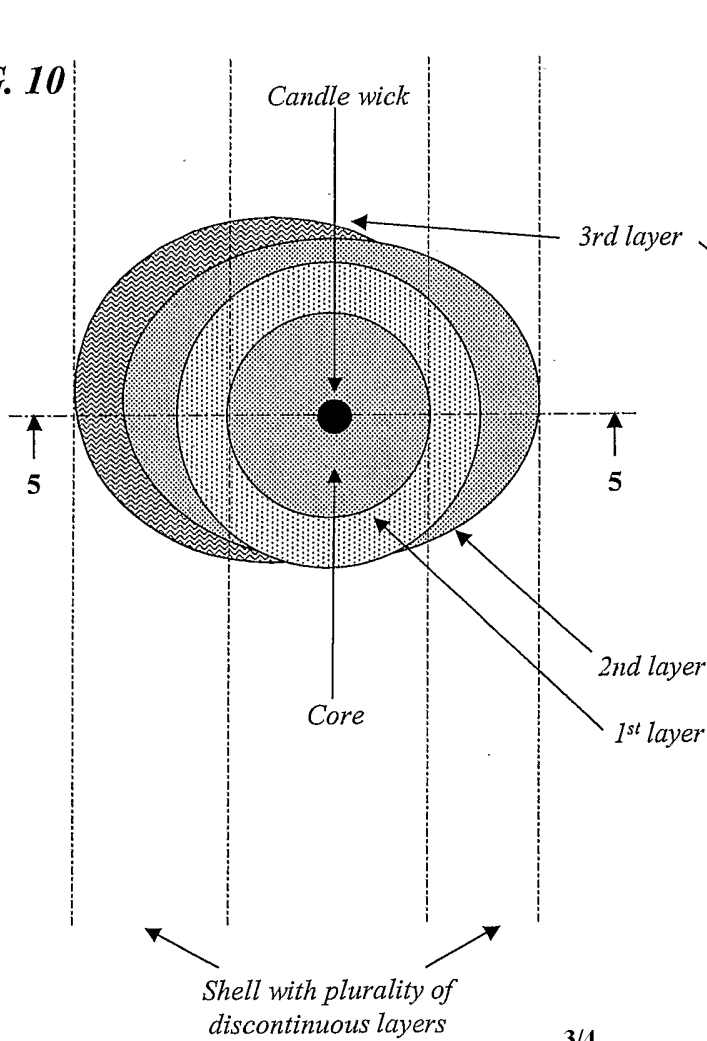

FIG. 11

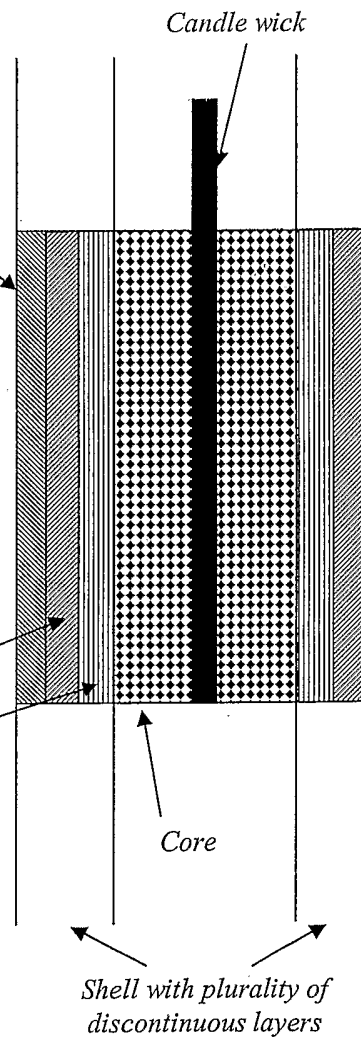

FIG. 12

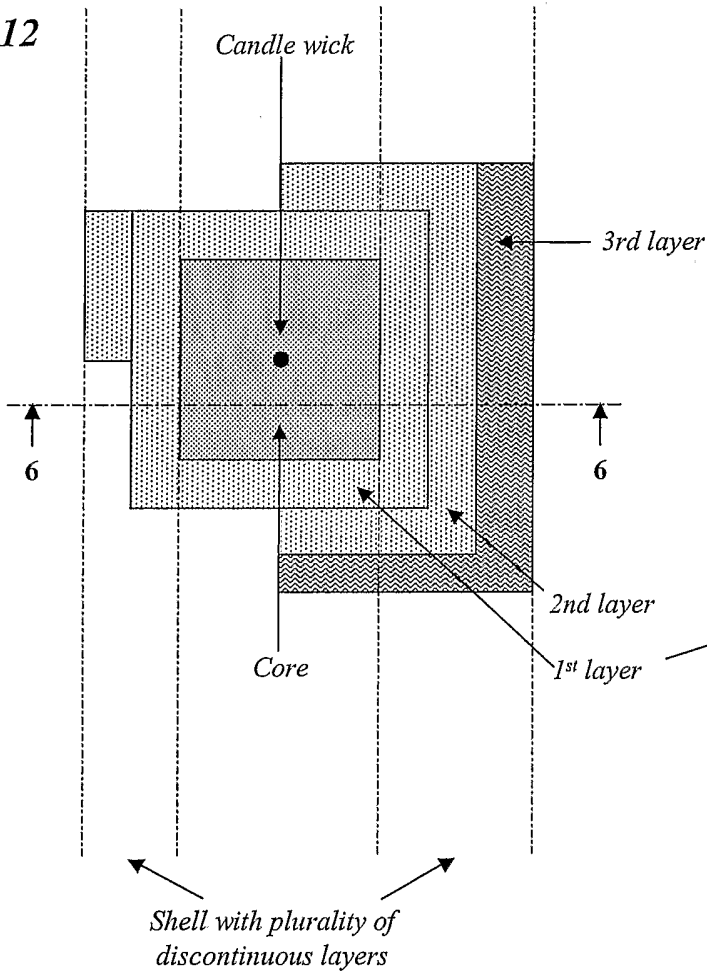

FIG. 13

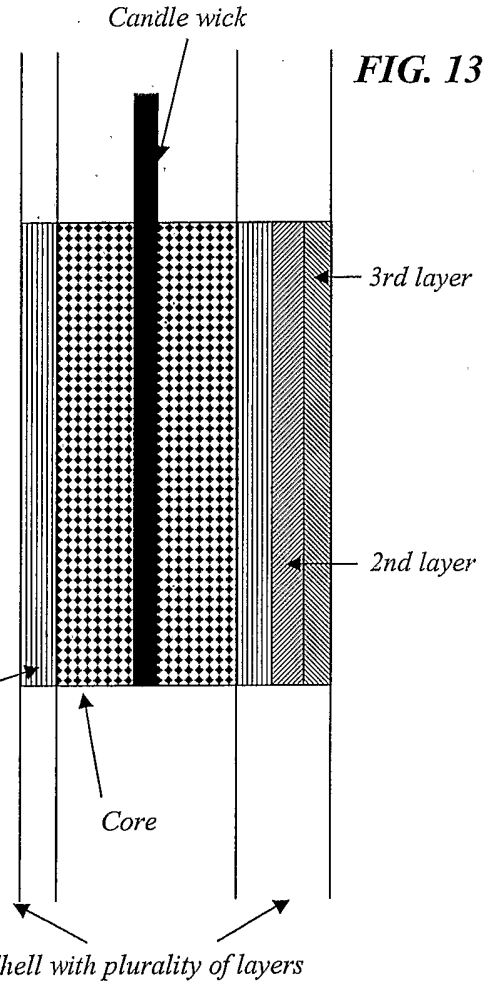
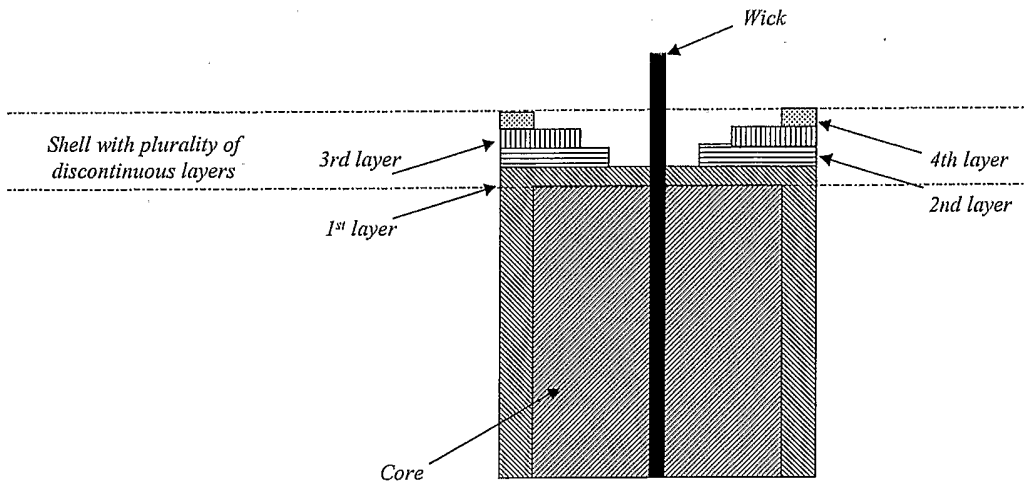

FIG. 14



INTERNATIONAL SEARCH REPORT

Internat	Application No
PCT/GB	03/00840

A. CLASSIFICATION OF SUBJECT MATTER IPC 7 C11C5/00		
According to International Patent Classification (IPC) or to both national classification and IPC		
B. FIELDS SEARCHED		
Minimum documentation searched (classification system followed by classification symbols) IPC 7 C11C		
Documentation searched other than minimum documentation to the extent that such documents are included in the fields searched		
Electronic data base consulted during the international search (name of data base and, where practical, search terms used) EPO-Internal, WPI Data, PAJ		
C. DOCUMENTS CONSIDERED TO BE RELEVANT		
Category °	Citation of document, with indication, where appropriate, of the relevant passages	Relevant to claim No.
X	US 6 079 975 A (CONOVER DONALD R) 27 June 2000 (2000-06-27) See whole document	1-4, 8-16, 18-21, 28-33, 37-40, 44-47, 49-51
X	US 4 568 270 A (MARCUS EDWARD J ET AL) 4 February 1986 (1986-02-04) cited in the application examples 1-16	1-5, 8-16, 18, 20-23, 28, 29, 34, 37-40, 44-49, 51
<input checked="" type="checkbox"/> Further documents are listed in the continuation of box C. <input checked="" type="checkbox"/> Patent family members are listed in annex.		
° Special categories of cited documents :		
A document defining the general state of the art which is not considered to be of particular relevance *E* earlier document but published on or after the international filing date *L* document which may throw doubts on priority claim(s) or which is cited to establish the publication date of another citation or other special reason (as specified) *O* document referring to an oral disclosure, use, exhibition or other means *P* document published prior to the international filing date but later than the priority date claimed *T* later document published after the international filing date or priority date and not in conflict with the application but cited to understand the principle or theory underlying the invention *X* document of particular relevance; the claimed invention cannot be considered novel or cannot be considered to involve an inventive step when the document is taken alone *Y* document of particular relevance; the claimed invention cannot be considered to involve an inventive step when the document is combined with one or more other such documents, such combination being obvious to a person skilled in the art. *&* document member of the same patent family		
Date of the actual completion of the international search 25 June 2003		Date of mailing of the international search report 04/07/2003
Name and mailing address of the ISA European Patent Office, P.B. 5818 Patentlaan 2 NL - 2280 HV Rijswijk Tel. (+31-70) 340-2040, Tx. 31 651 epo nl, Fax: (+31-70) 340-3016		Authorized officer Rooney, K

INTERNATIONAL SEARCH REPORT

Internatl	Application No
PCT/GB	03/00840

C.(Continuation) DOCUMENTS CONSIDERED TO BE RELEVANT		
Category °	Citation of document, with indication, where appropriate, of the relevant passages	Relevant to claim No.
X	<p>US 5 961 967 A (PENDERGRASS JR DANIEL B ET AL) 5 October 1999 (1999-10-05)</p> <p>column 2, paragraph 5 -column 3, paragraph 3; example 1</p> <p>---</p>	<p>1-9, 19-23, 28-30, 32-34, 37, 40, 42-49, 51</p>
X	<p>US 6 129 771 A (FICKE GEOFFREY T ET AL) 10 October 2000 (2000-10-10)</p> <p>See whole document</p> <p>---</p>	<p>1-21, 28-40, 49-51</p>
X	<p>US 2002/022205 A1 (PENRECO) 21 February 2002 (2002-02-21)</p> <p>page 2, column 1, paragraph 4 page 5, column 2, paragraph 1 -page 6, column 1, paragraph 3 claim 1</p> <p>-----</p>	<p>1-51</p>

INTERNATIONAL SEARCH REPORT

Information on patent family members

Internati	Application No
PCT/GB 03/00840	

Patent document cited in search report		Publication date	Patent family member(s)	Publication date
US 6079975	A	27-06-2000	NONE	
US 4568270	A	04-02-1986	NONE	
US 5961967	A	05-10-1999	NONE	
US 6129771	A	10-10-2000	NONE	
US 2002022205	A1	21-02-2002	AU WO	7524101 A 0194507 A2 17-12-2001 13-12-2001