

May 21, 1929.

J. E. KENNEDY

1,714,312

DISINTEGRATING APPARATUS

Filed March 31, 1924

7 Sheets-Sheet 1

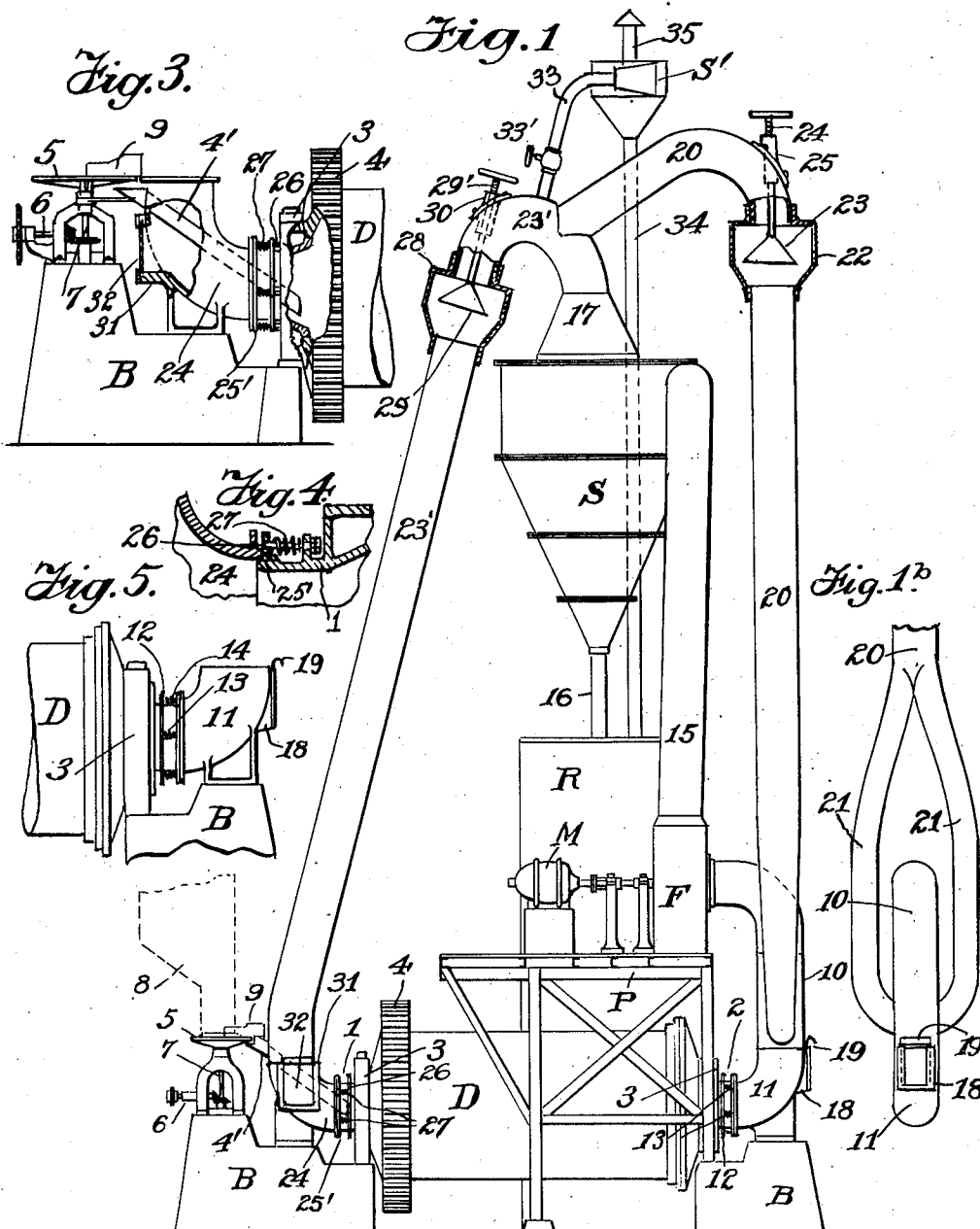

INVENTOR

Joseph E. Kennedy
BY
John D. Seifert
HIS ATTORNEY

May 21, 1929.

J. E. KENNEDY

1,714,312

DISINTEGRATING APPARATUS

Filed March 31, 1924

7 Sheets-Sheet 2

Fig. 1^a

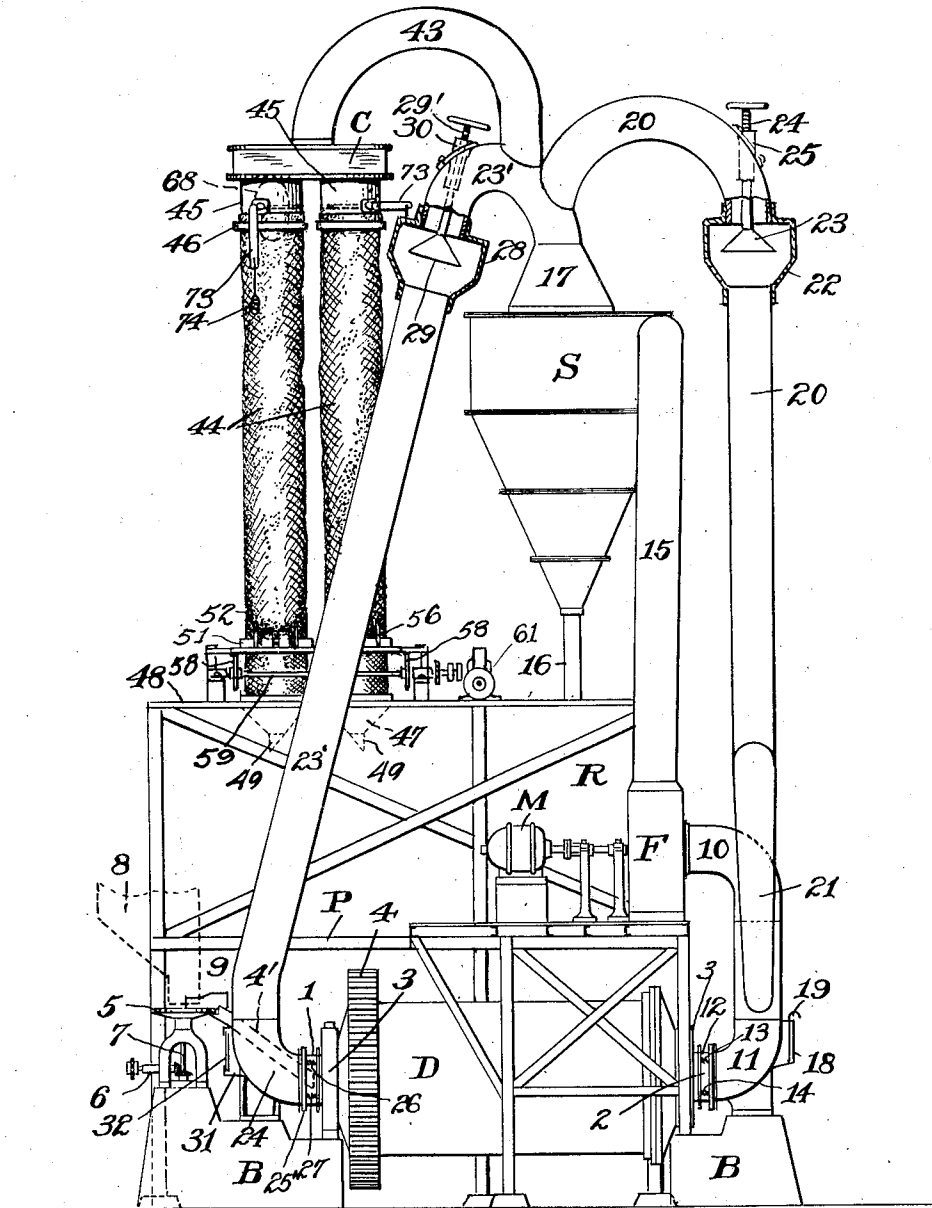

INVENTOR

Joseph E. Kennedy
BY
John D. Siefert
HIS ATTORNEY

May 21, 1929.

J. E. KENNEDY

1,714,312

DISINTEGRATING APPARATUS

Filed March 31, 1924

7 Sheets-Sheet 3

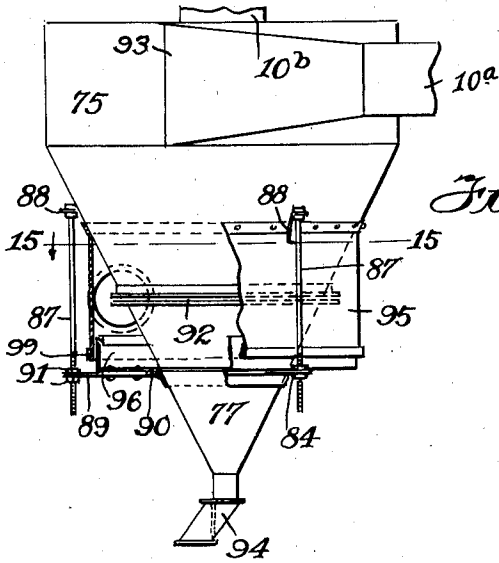

Fig. 14.

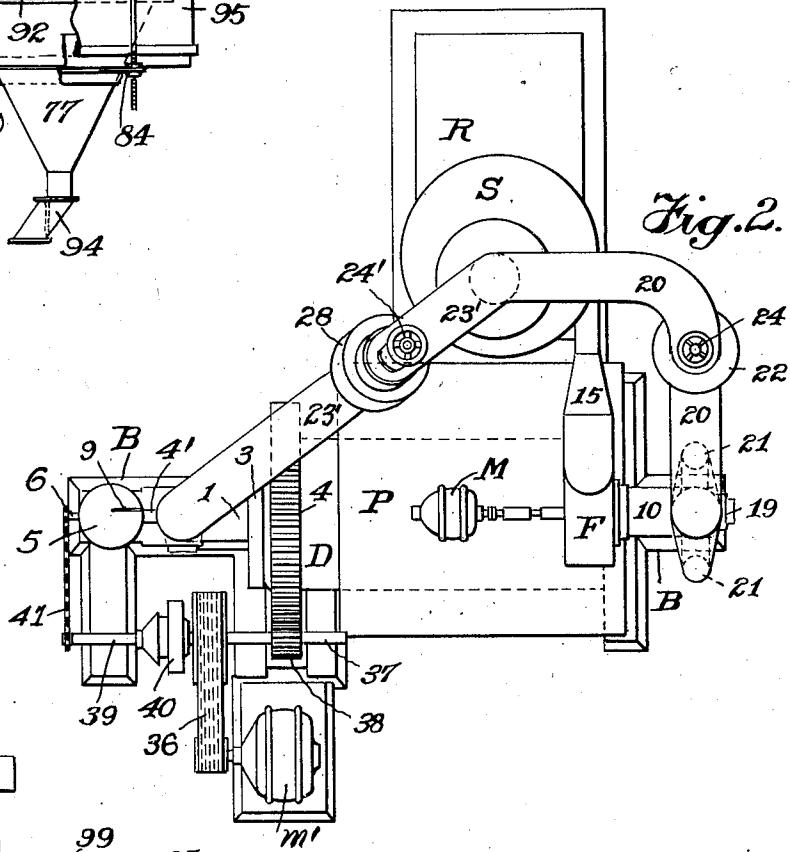

Fig. 2.

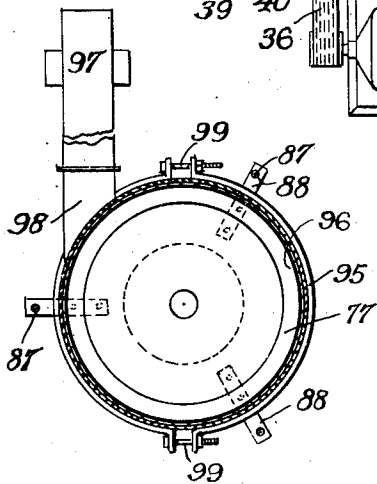

Fig. 15.

INVENTOR
Joseph E. Kennedy
BY
John D. Seifert
HIS ATTORNEY

May 21, 1929.

J. E. KENNEDY

1,714,312

DISINTEGRATING APPARATUS

Filed March 31, 1924

7 Sheets-Sheet 4

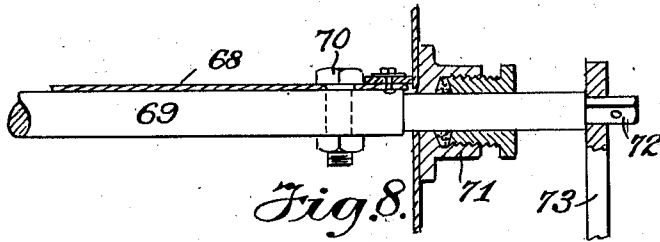

Fig. 8.

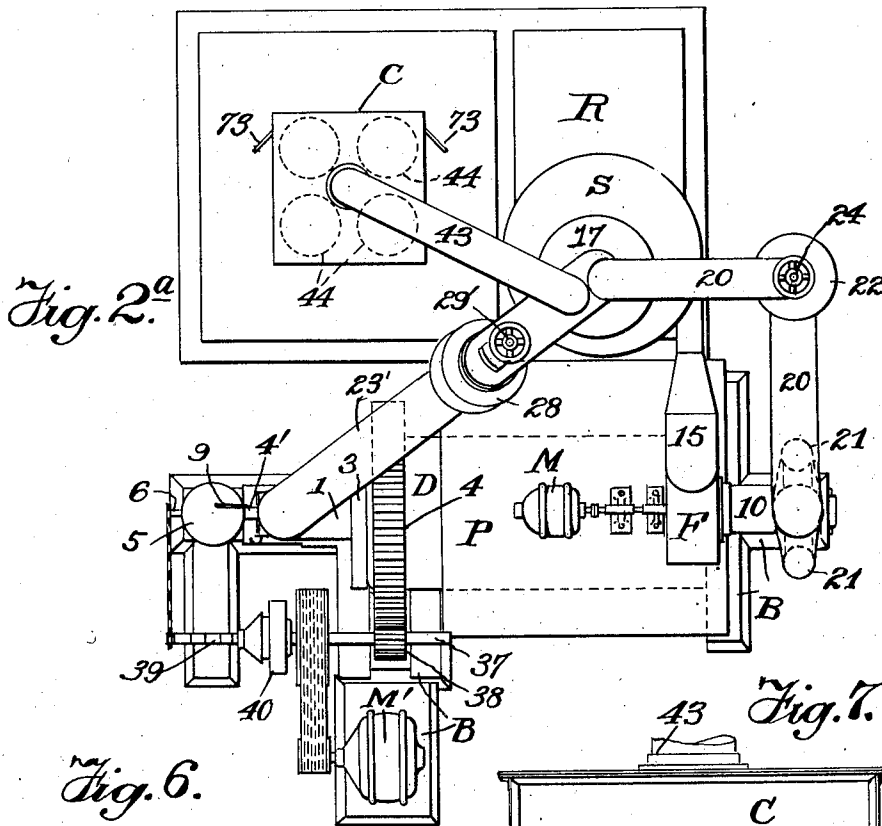

Fig. 2a.

Fig. 6.

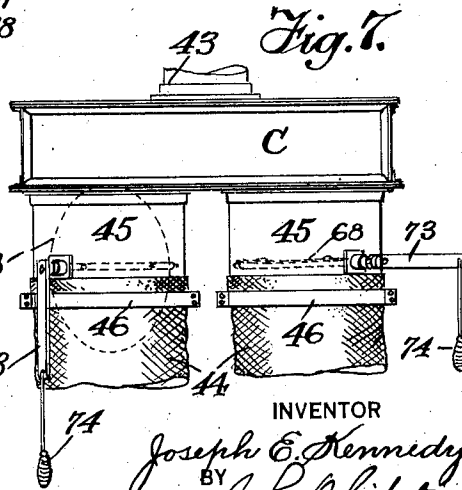
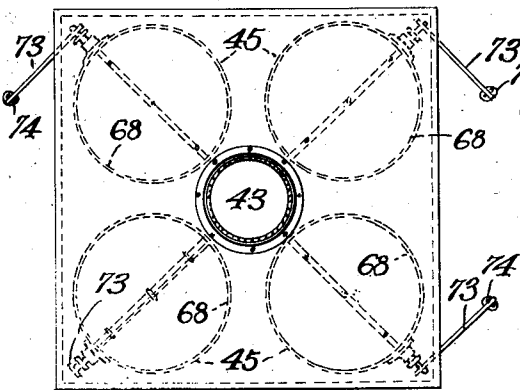

Fig. 7.

INVENTOR
Joseph E. Kennedy
 BY *John P. Siefert*
 HIS ATTORNEY

May 21, 1929.

J. E. KENNEDY

1,714,312

DISINTEGRATING APPARATUS

Filed March 31, 1924

7 Sheets-Sheet 5

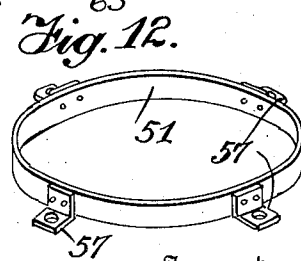
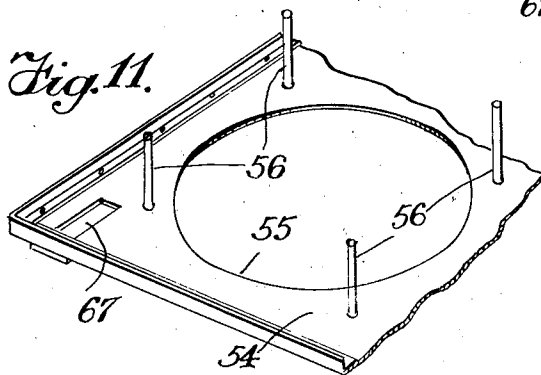
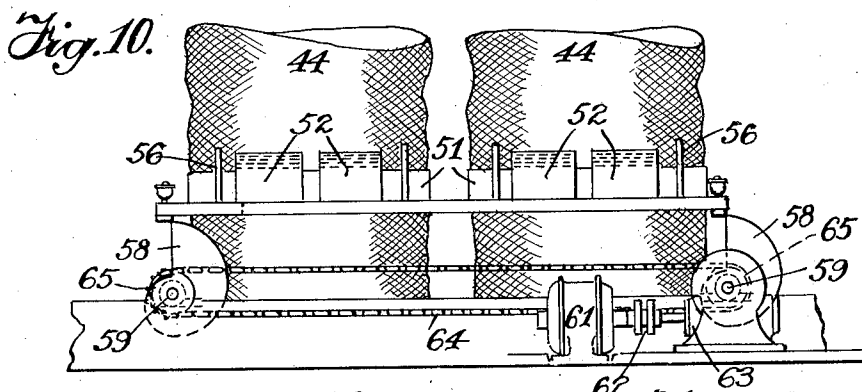
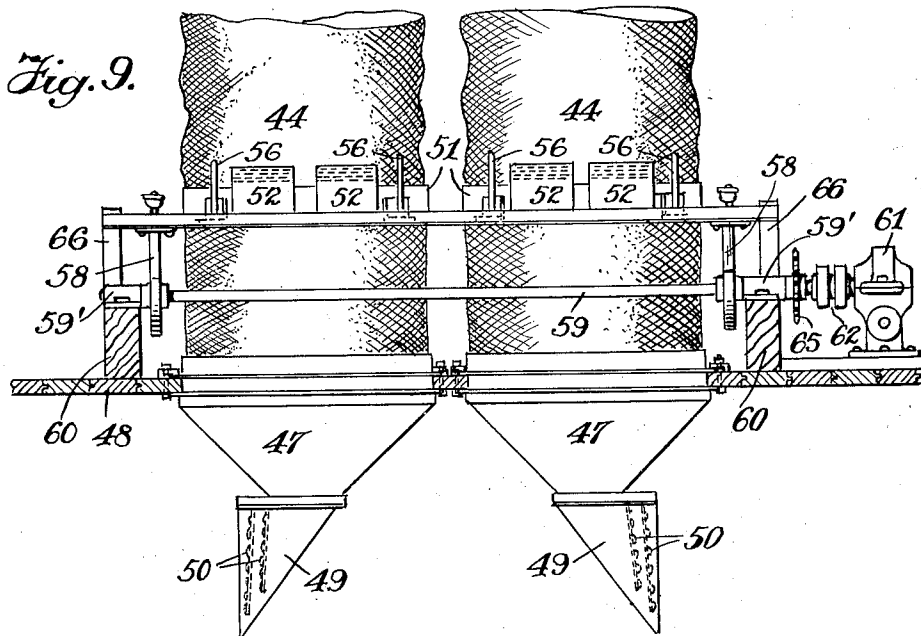

Inventor
Joseph E. Kennedy
By *John O. Seifert*
His Attorney

May 21, 1929.

J. E. KENNEDY

1,714,312

DISINTEGRATING APPARATUS

Filed March 31, 1924

7 Sheets-Sheet 6

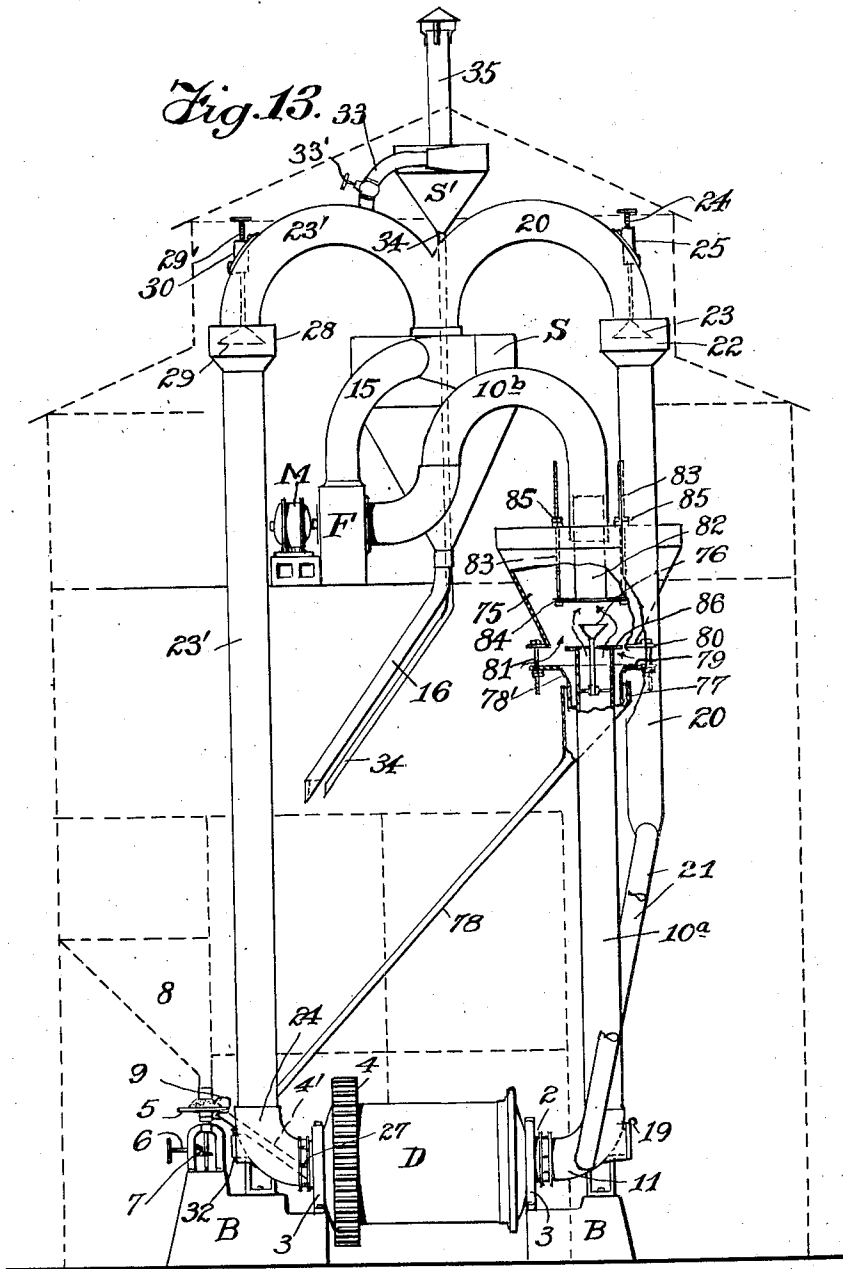

Inventor
Joseph E. Kennedy
By his Attorney *John O. Seifert*

May 21, 1929.

J. E. KENNEDY

1,714,312

DISINTEGRATING APPARATUS

Filed March 31, 1924

7 Sheets-Sheet 7

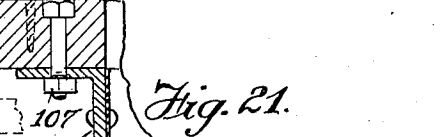
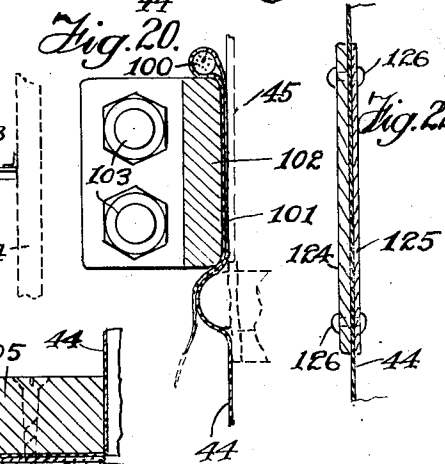
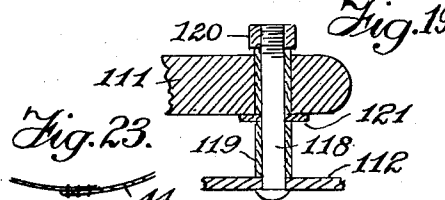
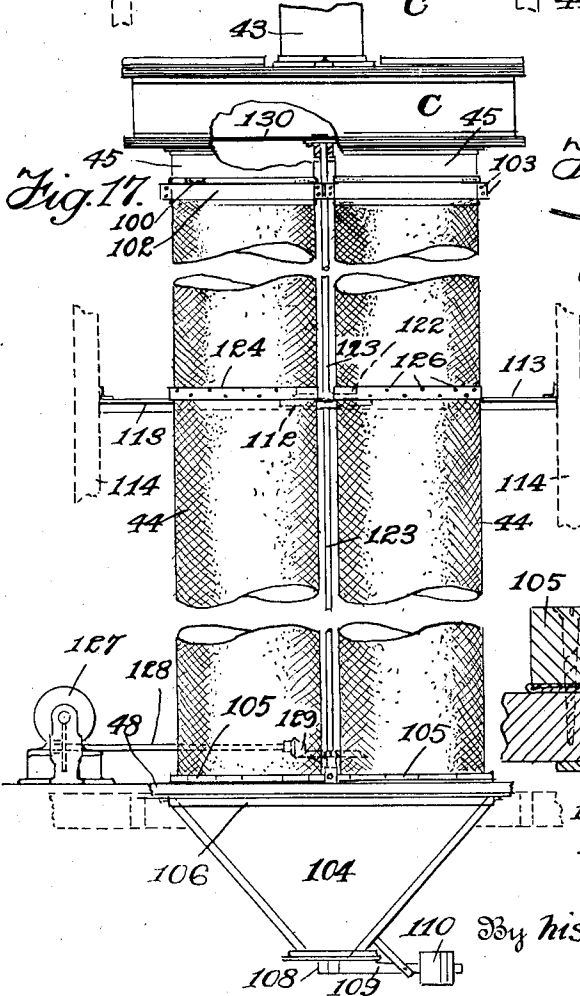
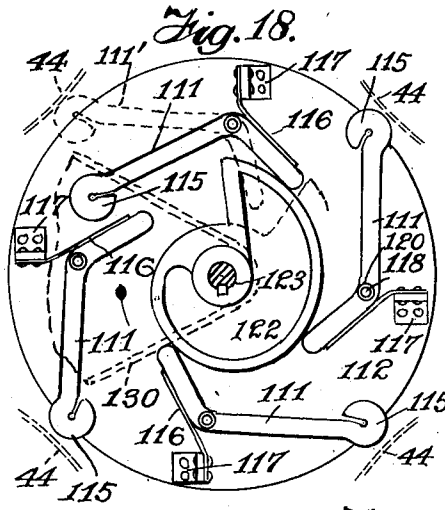
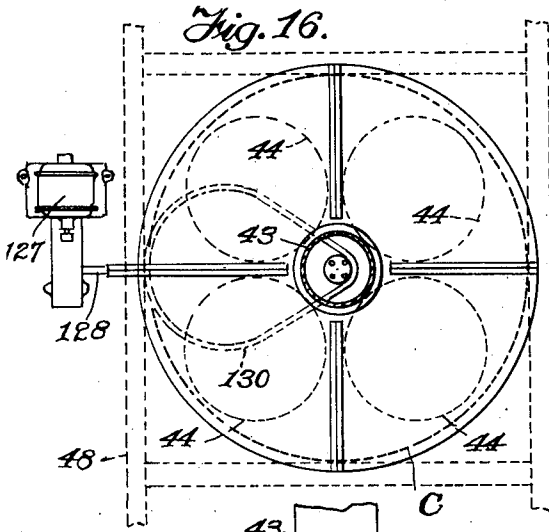

Inventor
 Joseph E. Kennedy
 By his Attorney John O. Siefert

UNITED STATES PATENT OFFICE.

JOSEPH E. KENNEDY, OF NEW YORK, N. Y.

DISINTEGRATING APPARATUS.

Application filed March 31, 1924. Serial No. 703,112.

This invention relates to apparatus for disintegrating or pulverizing material, such as coal, lignite, ore, rock, bone, etc., and relates particularly to apparatus of this character wherein material is fed to and disintegrated in a drum or chamber and the disintegrated material is delivered by pneumatic means, and it is the primary object of the invention to provide an improved construction and arrangement of apparatus of this character whereby a highly efficient result is produced and the capacity for the treating of material is greatly increased as compared with other apparatus of the same size.

It is the principal object of the invention to provide in connection with disintegrating apparatus means to control the pneumatic delivery means of the disintegrating apparatus whereby a product may be produced of any degree of fineness.

It is a further object of the invention to construct and arrange the pneumatic means whereby the spent air from separating means to separate material, such as dust from air, may be returned to the intake of a fan of pneumatic means to facilitate the lifting of the material by said fan or to the disintegrating drum to facilitate the drawing of material and thereby material of different degrees of fineness from the drum.

It is another object of the invention to provide in connection with the pneumatic means of apparatus of this character means connected to the outlet of separating means connected to the delivery side of the fan of the pneumatic means to assure the separation and collection of all of the dust from the air.

Another object of the invention relates to apparatus of this character of means interposed in the connection of the pneumatic means with the disintegrating chamber or drum whereby to effect a preliminary separation of material from the air drawn from the disintegrating drum or chamber and either deliver such material to a receiver therefor or return the same to the drum for further treatment.

A further object of the invention relates to apparatus of this character of the provision of a separator to effect a preliminary separation of material from the air drawn from the drum, which separating means is adapted to be connected in circuit with the pneumatic means or shut off therefrom.

Another object of the invention relates to an improved constructed and arranged sep-

arator whereby the air in its passage through the separator is subjected to a winnowing action to facilitate the separation of material from the air as it enters said separator.

Other objects and advantages will hereinafter appear.

In the drawings accompanying and forming a part of this specification I have illustrated apparatus for carrying out my invention wherein Figure 1 is an elevational view, partly in section, of one embodiment thereof.

Figure 1^a is a view similar to Figure 1 and showing an improved construction and arrangement embodying an auxiliary separating and collecting means to which the outlet means of the main separator and collecting means is connected to assure the separating of all of the disintegrated material or dust from the air.

Figure 1^b is an elevational view looking at the left of Figure 1 to show the air connections at the intake side of the pneumatic means.

Figure 2 is a plan view of the apparatus shown in Figure 1.

Figure 2^a is a plan view of the apparatus shown in Figure 1^a.

Figure 3 is an elevational view, partly in section, of the charging end of a disintegrating drum or chamber showing the means for feeding the material to said drum to be disintegrated.

Figure 4 is a detail view in sectional side elevation to show the connection between the pneumatic means and the disintegrating chamber to maintain a substantially air tight connection between the same.

Figure 5 is a detail view in side elevation of the connection of the pneumatic means with the delivery of the disintegrating drum.

Figure 6 is a plan view of a chamber interposed in the connection of the auxiliary and main separating and collecting means.

Figure 7 is a side elevation of the chamber shown in Figure 6 and showing the connection of the auxiliary separating and collecting means thereto.

Figure 8 is a longitudinal sectional view, on an enlarged scale, of valve means for shutting off the auxiliary separating and collecting means shown in Figures 6 and 7 and thereby from the main separating and collecting means.

Figure 9 is a view on an enlarged scale of the lower portion of the auxiliary separating and collecting means.

Figure 10 is a view looking at the right of Figure 9.

Figures 11 and 12 are detail views in perspective of means forming a part of the auxiliary separating and collecting means.

Figure 13 is a view similar to Figure 1 showing a modified construction and arrangement whereby a primary separator is arranged in the connection of the pneumatic or suction creating means with the disintegrating drum or chamber with means arranged to connect said separator into said connection or shut off the same from said connection, and showing the apparatus as installed in a building.

Figure 14 is a side elevation of a modified construction and arrangement of the separator shown in Figure 13 interposed between the connection of the pneumatic or suction creating means and the disintegrating drum.

Figure 15 is a cross sectional view taken substantially on the line 15—15 of Figure 14.

Figure 16 is a plan view and

Figure 17 is a side elevation of a modification of the auxiliary separating and collecting means connected to the main separator shown in Figure 1^a.

Figure 18 is a plan view of means operative to agitate the screen wall of the separating and collecting means shown in Figures 16 and 17.

Figure 19 is an enlarged sectional detail view to show the mounting of the agitating means shown in Figure 18.

Figures 20 and 21 are enlarged sectional detail views to show the manner of securing the ends of the screen walls of the separating means shown in Figure 17.

Figure 22 is an enlarged sectional view of striker plates attached to the wall of the screen chambers for the agitating means to strike against; and

Figure 23 is a cross sectional detail view to show the manner of securing the material of the screen walls of the supporting means shown in Figure 17.

Similar characters of reference designate like parts throughout the different views of the drawings.

The embodiment of the invention is illustrated in its simplest form in Figures 1 to 5, inclusive, of the drawings wherein the material is disintegrated in a drum or chamber D rotatably supported by axially arranged trunnions 1 and 2 journaled in bearings in pillow blocks 3 mounted upon a suitable base B, shown in the present instance as constructed of concrete, the drum being revolved from a suitable source of power through a gear 4 encircling and fixed to the drum. The grinding means comprises elements within the drum which are freely movable during the revolving of the drum, such as hardened steel balls. The material to be disintegrated is fed to the drum through the trunnions 1 by

means of a chute 4' leading from a feeding disk 5 supported to rotate in a horizontal plane and driven from a suitable source of power by a shaft 6 geared to a shaft 7 operatively connected to the disk. The disk is positioned at the outlet of a chute from a bin 8 to receive material therefrom and the material is directed from the disk into the chute 4' by a fixed scoop 9.

The opening through the trunnion 2 serves as a delivery opening, the disintegrated material being withdrawn from the drum through the action of pneumatic means comprising a suction fan (designated in a general way at F) mounted upon a platform P and driven by an electric motor M, the intake of the fan being connected by a pipe 10 having an elbow connection 11 with the drum trunnion 2 by means of which elbow the load capacity of the drum may be maintained. The elbow is mounted in fixed position and has a substantially air-tight connection with the trunnion 2 for which purpose the diameter of the trunnion is such that it will extend slightly into the elbow 11, as clearly shown in Figure 4, a collar 12 being mounted on the trunnion to participate in the rotative movement thereof and have sliding axial movement thereon and urged into engagement with the end of the elbow 11 by springs 13 coiled about pins 14 fixed in lugs extending laterally from the trunnion and slidably engaging in perforations in the collar, there being a number of these springs circumferentially disposed about the trunnion.

The air drawn from the drum with disintegrated material in the form of particles of material and dust is delivered by the fan F through a pipe 15 connected to the outlet of the fan to a cyclone separator S of an approved type having an outlet pipe 16 leading from the bottom for the delivery of material separated from the air delivered by the fan to the separator to a receiver R in the form of a bin which may be mounted upon the platform P. The separator has an outlet at the top through a pipe 17 for the spent air delivered to the separator by the fan. To facilitate the lifting of material by the fan drawn from the drum through its connection with the drum and to regulate the degree of fineness of material drawn from the drum means are provided for an additional air supply to the fan of the pneumatic means through said pipe 10, for which purpose said connection of the fan is adapted to be connected to the atmosphere to a variable extent by arranging an opening to the atmosphere in said connection, said opening in the present instance being arranged in the elbow 11, as at 18, and regulated by a valve in the form of a closure plate 19 slidably mounted in the walls of said opening.

To permit the fan to draw and deliver relatively coarse material from the drum I pro-

vide for an auxiliary and additional air supply to the fan to facilitate the lifting and delivery of said material by the fan, the air from the separator S is returned to the connection of the fan with the drum by the pipe 20 connected to the outlet pipe 17 of the separator, said pipe being connected to the connection 10 of the fan with the drum by branch pipes 21 leading from the pipe 20 to the pipe 10 at opposite sides thereof. By this arrangement material which may be delivered with the air from the separator is again returned by the fan to the separator with material drawn from the drum by the fan. To regulate and control or shut off the connection of the separator S with the connection of the fan to the drum trunnion 2 through the pipe 20 a valve mechanism is arranged in said pipe comprising a valve chamber 22 and a valve 23 of conical shape carried by a stem 24 threaded in a boss 25 and having a hand wheel exterior of the pipe to manipulate the valve. The valve is arranged so that the conical wall will seat against the pipe section connected to the top of the valve chamber to shut off communication between the separator S and the connection 10 of the fan with the drum trunnion, and as the valve is moved away from its seat the area of the valve chamber to said valve will be substantially equal to that of the cross sectional area of the pipe to facilitate a free flow of air past the valve. It will be obvious that the connection through the pipe 20 may be controlled and regulated by the valve at will.

To facilitate the delivery of a product of still greater coarseness means are provided to cause a strong current of air to be drawn through the drum for which purpose the pneumatic means is connected in circulation with the charging opening of the drum through the trunnion 1 by a pipe 23' leading from the air outlet 17 of the separator S and connected to the charging opening of the drum by an elbow 24', said elbow having substantially an air tight connection with the drum trunnion 1 similar to the elbow 11 with the trunnion 2, the elbow being of a diameter to permit of the trunnion to engage slightly therein, a collar 25 being mounted by means of pins 26 (Figure 3) on the drum trunnion to participate in the rotative movement thereof and have axial sliding movement thereon and urged into contact with the end of the elbow by springs 27 coiled about the collar carrying pins 26. The connection of the separator S with the trunnion of the drum is regulated and controlled or shut off by valve mechanism similar to that interposed in the pipe 20 and consisting of a valve chamber 28 having a conical valve 29 therein to seat against the connection of the pipe 23' with the top of the valve chamber to shut off connection of the separator with the charging opening of the drum, said valve being

carried by a stem 29' threaded into a boss 30.

In some instances to deliver material of a certain degree of coarseness from the drum it may be found desirable and necessary to provide an auxiliary air supply to the entrance side of the fan to facilitate the lifting of the material, when the spent air from the separator S is connected to the intake side of the fan through the pipe 20. Should the separator S be connected with the charging opening of the drum through the pipe 23' to assure a sufficient air supply to be drawn through the drum there might not be a sufficient air supply from the separator S through the pipe 20 to the intake side of the fan to effect the lift of the material with the air. In such case the separator S through the pipe 23' is shut off by the valve 29. To supply additional air to the drum the elbow 24 is arranged with an opening 31 the area of which opening and the connection therethrough of the drum with the atmosphere is regulated and controlled by a valve in the form of a plate 32 slidably mounted in the member 31. Should it be desired that the product be a very coarse material the separator S is shut off from the drum and fan through the pipes 23', and 24, and to assure a strong current of air being drawn through the drum the charging end of the drum is connected with the atmosphere through the opening 31 which is controlled by the valve 32. In this latter condition should it be desired to provide an additional supply of air to the fan to facilitate the lifting and delivery of material drawn from the drum by the air blast the intake side of the fan is connected to the atmosphere through the opening 18 in the connection of the fan with the drum. In this case the air from the separator S is delivered to the atmosphere and to assure the separating of practically all of the particles of material and dust from the spent air discharged from the separator S an auxiliary separator S' is provided, the inlet of said separator being connected to the air outlet 17 of the separator S by a pipe 33 which may be controlled and regulated by a valve 33' therein. The auxiliary separator has an outlet for the separated material with a pipe 34 connected thereto leading to a receiver for the separated material, and which may be led to the bin R. The air is exhausted from the separator S' to the atmosphere through an outlet pipe 35.

The drum is driven from a motor M' having a chain or belt drive connection 36 with a shaft 37 (Figure 2) having a pinion 38 meshing with the drum gear 4. The feeder disk 5 is also driven from said shaft 37 by a shaft 39 having a clutch connection 40 with the shaft 37. The shaft 39 is operatively connected to the driving shaft 6 for the feeding disk by a sprocket chain 41 passing around sprocket wheels on shafts 39 and 6.

To assure the separating and collecting of all the dust from the spent air delivered from the outlet 17 of the separator S when the air returned to the drum or the connection of the fan with the drum is shut off through pipes 23', 20, instead of utilizing the auxiliary separator S', there is connected to the air outlet 17 of the separator S a pipe 43, in the present instance shown leading from the pipe 23' in line with the separator outlet 17 to a chamber C (Figures 1^a, 2^a, 6 and 7) to which chamber is connected one or more chambers 44 having flexible screen walls, there being four of these chambers shown in the present instance, connected at one end to tubular portions 45 projecting down from and communicating with the chamber. The wall of the flexible chambers comprise a fabric, such as bagging, and are secured to the chamber outlet members 45 by clamping rings 46 to be suspended from the members 45. The lower ends of the chambers 44 are connected to receivers 47 supported by a platform 48 below which a bin may be located, said receivers 47 having outlet chutes 49 the outlet of which is closed by gravity valves 50 adapted to be opened by the weight and pressure of material accumulated in the receivers. (Figures 1^a and 9). The bags are of a length greater than the distance between the platform 48 and their connection with the tubular members 45. The discharge from the separator S to the bags through the chamber 44 is expelled to the atmosphere through the interstices between the fibres of the fabric of the bagging and any dust carried by the air will be separated therefrom in its passage from said interstices and lodged on the inner surface of the bags. To dislodge the material accumulated on the surface of the bags they are alternately flexed and drawn taut. For this purpose the bags are weighted adjacent the lower ends by attaching metallic rings 51 thereto (Figure 12), said rings being attached to the bags by loops of material 52, such as fabric, through which the rings are passed and the loops attached to the bags as by stitching. These rings are alternately raised to arrange a slack portion in the bags above the rings, or as herein termed "flexed", and caused to drop to draw the bags taut, and thereby cause any material which has become lodged on the bags due to the air passing through the interstices of the material on the bags, to be dislodged by the snapping of the bags and drop into the receivers 47. To alternately raise the rings and release them to permit them to drop a frame 54 (Figure 11) is provided, said frame having openings 55 for the passage of the lower portions of the bags, and the rings 51 are positioned relative to said frame by guide pins 56 projecting up through said frames and slidably engaging in lugs 57 fixed to and projecting laterally from the rings. The frame is reciprocated longitudinally of the bags by cams 58 on a pair of parallel shafts 59 journaled in bearings 59' mounted on sills 60 on the platform 48, as clearly shown in Figures 9 and 10. The cam shafts are rotated from a suitable source of power, shown as a motor 61 directly connected by a clutch 62 with one of the shafts, as shown in Figure 9, or through intermediate gearing 63 as shown in Figure 10, the other of the shafts 59 being driven from the shaft to which the motor is connected by a sprocket chain 64 passing around sprocket wheels 65 on the shafts 59. The frame 54 is guided in its movement by guides 66 (Figure 9) fixed to and projecting up from the sills 60 arranged adjacent the corners of the frame and engaging in openings 67 thereon (Figure 11). To absorb the shock and consequent noise as the frame with the rings drop by riding off the high portions of the cams cushions or bumpers of rubber are arranged upon the sills 60.

To shut off either one of the bags from the chamber C and thereby from the separator S, or all of said bags from the separator, when the air from the separator is to be returned either to drum or the connection of the separator with the intake side of the fan, or to both, and to regulate the connection of the bags with the chamber C, valves are provided which are in the nature of dampers 68 arranged in the tubular outlet members 45, these dampers being of a size substantially the same as the inner diameter of said outlet members. The dampers or valves are fixed to spindles 69, as by bolts 70 passing through said dampers and the spindles (Figure 8) and journaled in stuffing boxes 71 arranged at the outer side of the outlet members 45. To manipulate the dampers to adjust the same one end of the damper carrying spindles is extended through a stuffing box 71 and has the extremity 72 squared for the mounting of an actuating arm or lever 73 thereon, each of the levers having a link 74 arranged with a hand grip pivotally connected thereto to facilitate the manipulation of the levers. The stuffing boxes 71 may be so arranged as to frictionally retain the damper carrying spindles with the dampers in any position to which they may be adjusted, or if desired means may be provided to cooperate with the levers 73 to retain the same and the dampers in adjusted position.

In Figure 13 I have shown an arrangement of apparatus as illustrated in Figure 1 installed in a building. However, instead of connecting the intake of the fan directly in circuit with the drum trunnion 2 by the pipe 10 a separator is provided which is adapted to be connected into or shut off from the connection of the fan with the drum whereby to effect a primary separation of material from the air withdrawn from the drum by the fan. In the present instance this separator is

shown in the form of an inverted conical chamber 75 interposed between two sections of pipe 10^a leading from the drum trunnion 2 into the bottom of said chamber and a section 10^b leading from the top of the chamber to the intake of the fan. The air is drawn by the fan from the disintegrating drum through the separator chamber 75 to the intake of the fan. The pipe section 10^a carries at the outlet thereof within the chamber 75 a baffle 76 in the form of an inverted conical member against which the air entering the chamber from the pipe strikes against, the conical surface of said baffle tending to retard the flow of the air currents and direct them laterally and thereby causing coarse and heavy particles of material which may have been withdrawn from the drum to be separated from the air. This separated material gravitates to a collecting chamber 77 arranged coaxially at the bottom of and in communication with the chamber 75 and through which the pipe section 10^a passes, this collecting chamber having an outlet at the bottom to which a chute 78 is connected for the delivery of the separated material which may be delivered to a bin for said material, or such chute may lead back to the air return pipe 23' to the drum and thereby to the drum for further treatment.

To effect a winnowing action of the air and thereby facilitate the separation of coarse particles of material from the air as it enters the separator chamber 75 from the pipe 10^a means are provided to open said chamber to the atmosphere to cause the fan to draw air into the separator independent of the air drawn into the chamber through said pipe section and to control the volume of air so drawn into the chamber. For this purpose the collecting chamber 77 is spaced from the lower portion of the separator chamber 75, which space is adapted to be opened or closed by a sleeve 78' telescoping into the collecting chamber 77. To adjustably support said sleeve it is arranged with an annular outwardly extending flange 79 and the lower end of the separator chamber 75 has an outwardly extending annular flange 80, bolts 81 passing through openings circumferentially disposed about the flanges 79 and 80 with the heads engaging below the flange 79 and nuts threaded onto the ends projecting through the openings in the flange 80. It will be obvious that by screwing said nuts onto the bolts the sleeve flange 79 may be drawn up close to the flange 80 of the separator chamber to entirely close said space, or by unscrewing the nuts a space of variable extent open to the atmosphere may be provided between the sleeve and separator chamber.

To shut off the separator chamber 75 from the connection of the fan with the drum through the trunnion, or to connect said chamber into said connection, a sleeve 82 of

the same diameter as the pipe section 10^a has a telescoping connection with the pipe section 10^b and thereby adjustment into and out of the separator chamber. This telescoping pipe section 82 is carried by rods 83 connected at one end to an annular flange or lugs 84 extending laterally from the end of the pipe within the separator chamber and passing through perforations in the top of the separator and bosses fixed to the top of said chamber with nuts 85 threaded onto said rods at the outside of the separator chamber. It will be obvious that by screwing the nuts 85 off from the rods that the pipe section 82 may be adjusted so that the flanged end 84 will engage with the end of the pipe section 10^a within the separator chamber, and to assure a relatively tight connection the end of the pipe 10^a within the separator may also be arranged with a laterally extending annular flange 86. By screwing the nuts onto the rods the pipe section 82 will be adjusted up into the pipe section 10^b and thereby connecting the separator chamber 75 into the connection of the fan with the drum trunnion 2.

In Figures 14 and 15 I have shown a modified arrangement of primary separator to be interposed in the connection of the intake side of the fan with the outlet trunnion 2 of the drum. In this arrangement the chamber section 77 is adjustable relative to and away from the section 75 instead of said section 77 being fixed in spaced relation to the section 75 and having an adjustable sleeve to open the separator to the atmosphere and shut it off therefrom as shown in Figure 13. The chamber section 77 is adjustably carried by the chamber section 75 by headed tie rods 87 passing down through perforations in brackets 88 circumferentially disposed around and in spaced relation to the separator with the heads of the rods engaging said brackets, the threaded ends of said rods passing through perforations in arms 89 extending outward from an annular plate 90 in the opening of which plate the separator section 77 engages and is secured, the plate 90 with the separator section 77 being adjusted on said rods and locked in adjusted position by nuts 91. The line of separation of the separator sections is at 92 and by screwing the nuts onto or off from the rods 87 the separator section 77 is adjusted toward or away from the section 75 and thereby arranging an opening to the separator chamber at the point 92 to provide for an auxiliary air supply to the separator to effect a winnowing of the material separated from the air in its passage through said separating chamber and cause any dust carrying particles of material to be released and carried off through the outlet of the chamber through pipe 10^b. To assure a substantial air tight joint between the separator sections at the mating ends they are arranged with annular members of right angle form in cross

section. It will be obvious that by adjusting the separator section 77 relative to the section 75 that an opening of variable size may be arranged between the sections.

5 In this arrangement of primary chamber the pipe section 10^a connected to the drum trunnion 2 leads tangentially into the side of the chamber 75, as shown at 93, the separator in effect being a cyclone separator, the section 10 77 also serving as a collecting chamber for the separated material which is delivered through an outlet at the bottom of said chamber section arranged with a trap gate, as at 15 94; that is the outlet is arranged with a gravity valve or valves adapted to be opened to deliver the material by the weight and pressure of the material collected in the chamber section 77. The air is drawn from the drum through the separator the same as in the arrangement shown in Figure 13 and the suction of the fan also operates to draw air through space 92 between sections of the separator chamber. However, to assure an air supply to said space to effect a winnowing of 25 the separated material such space opens into a chamber arranged around the mating ends of the sections of the separator chamber and comprises an annular sleeve 95 fixed to and extending downwardly from the separator section 77, the plate 90 being arranged with an upwardly extending annular flange 96 of less diameter than the sleeve 95 and to have telescoping movement into and out from said sleeve by the adjustment of the chamber section 77 upon rods 87. Air is forced into the chamber formed by the sleeve 95 and plate 96 by a blower, shown in a general way at 35 97, connected to the sleeve by a pipe 98 arranged so that the air will enter the chamber tangentially thereof. To assure a substantial air tight connection between the sleeve 95 and plate flange 96 a clamping ring extends around the portion of the sleeve overlapping the plate flange, said ring comprising 45 a pair of sections drawn together by bolts engaging perforated ears at the end of the ring sections as at 99.

In Figures 16 and 17 I have shown a modified arrangement of the screen chambers 44 wherein the chamber C is of circular shape in plan and the chambers 44 are connected to the tubular outlet members 45 by wrapping the upper ends over an annulus or ring 100 (Figure 20) of suitable material, such as rope, with the loop portions 101 of the material clamped to the tubular members 44 by semi-circular bands 102 clamped to such members by bolts 103 passing through perforations in the laterally bent ends of said bands. The lower ends of said chambers are clamped to the marginal portions of openings in the platform 48 communicating with a hopper 104 by rings 105 secured to said platform, as shown in Figure 21. The hopper is secured 65 to the bottom of the platform 48 to receive

material from the chambers 44 by a supporting bracket 106 of angle iron attached to the upper marginal portions of the hopper and bolted to the bottom of the platform, as shown at 107. The walls of the chambers 44 in this arrangement are maintained substantially taut and by the arrangement of securing the upper ends to the outlet members 45, by the ring 100 and clamping members 102, any slack in the chamber walls may be readily 70 taken up by loosening the clamping bands 102. The hopper outlet is arranged with a trap gate to normally maintain the same closed consisting of a disk 108 carried at one end of a pivotally supported lever 109, the opposite end of said lever being arranged with a weight 110 which is operative to normally position the lever with the closure 108 to shut off the hopper outlet. The gate is actuated to discharge the material from the hopper by the weight and pressure of the accumulated material in the hopper. 85

To agitate the wall of the chambers 44 to dislodge material which has been separated from the air passing through the interstices of the material of said chamber walls I provide a series of beaters 111 in the nature of hammers pivotally supported intermediate their ends and circumferentially disposed about a disk 112 in interposed relation to the chambers 44 and substantially midway between the ends thereof, said disk being mounted on carriers 113 extending laterally from supports 114 which may be fixed to and extend up from the platform 48. The beaters or hammers are formed of bars each with one end bent upon itself, as at 115 to form an enlargement or head and bent to angular shape at the point of their pivotal support, the beaters being urged in a direction to move the ends with the enlargement outward toward the chambers by springs 116, shown as leaf springs, fixed at one end to brackets 117 fixed to the disk 112 with the free ends of the springs bearing against the ends of the beaters opposite to the ends having the enlargements. The beaters are pivotally supported upon the disk 112 in spaced relation thereto by means of bolts or studs 118 passing through perforations in the disk with the heads engaging below the disk, said studs also engaging in a bushing or sleeve 119 and upon which the beaters are mounted, nuts 120 threaded onto the end of the studs bearing against the end of the bushing securing the studs and bushings in vertical position. To maintain the beaters in spaced relation to the disk the bushing consists of sections with a collar 121 interposed between the sections to serve as a supporting seat for the beaters (Figure 19). 125

The beaters are caused to successively move laterally and forcibly strike against the walls of the bags or chambers 44 to agitate said walls to dislodge material which has been deposited thereon due to the air passing 130

through the interstices of the material of the wall by a cam 122 fixed to a shaft 123 to rotate in a horizontal plane in line with the beaters, the shaft extending through the disk and being journaled at opposite ends in bearings mounted on the chamber C and upon the platform 48. The cam is adapted to engage the ends of the beaters opposite the ends with the enlargements, and as said ends of the beaters ride upon the high portion of the cam the beater will be moved against the tension of the springs 116, and as the beaters ride off from the high portion of the cam the inherent tension of the springs will impart a sudden movement to the beaters causing the enlarged ends thereof to strike against the walls of the chambers, as shown at 111' in dotted lines in Figure 18. The wall of the chambers 44 as stated consists of fabric, such as bagging, and to prevent rupturing and tearing of such material by the successive striking of the beaters against the same they are arranged with a reinforcement in the region where the beaters strike against the same comprising a pair of bands of metal or leather, one band 124 being arranged at the outside and the other 125 being arranged at the inside and secured together in position on the chamber wall by rivets 126. The cam shaft 123 is rotated from a suitable source of power, shown as an electric motor 127 operatively connected to the shaft 123 by a shaft 128 having a suitable driving connection with the motor and a gear connection 129 with the cam shaft.

To prevent the separated material in the form of dust and of impalpable fineness accumulated on the walls of the chambers 44 from rising and entering into the chamber C when the chambers 44 are agitated by the striking of the beaters 111 against the same the chambers 44 are shut off from the chamber C at the time of the striking of the beaters against the same. For this purpose there is mounted on the end of the cam shaft projecting into the chamber C a valve or damper in the form of a plate 130 (Figures 16 and 17), this valve being arranged on the shaft in relation to the cam and its movement timed in relation to the movements of the beaters so that it will extend over and shut off a chamber 44 from the chamber C at the time that the wall of such chamber 44 is agitated by a beater striking against the same.

Having thus described my invention, I claim:

1. In disintegrating apparatus, a revoluble drum in which to disintegrate material having a charging opening and a discharge opening at opposite ends; pneumatic means connected to the discharge opening to draw air through the drum from the charging opening to the discharge opening and deliver disintegrated material from the drum; a separator connected to the delivery side of the

pneumatic means having an outlet for the separated material and an air outlet; a chamber having a flexible screen wall connected to the air outlet of the separator to expel air to the atmosphere through the interstices of the screen and separate dust from the air as it is expelled; outlet means from said chamber; and means to flex the wall of said chamber to dislodge dust separated and collected on the surface thereof to be delivered from the outlet means.

2. In disintegrating apparatus, a revoluble drum in which to disintegrate material having a charging opening at one end and a delivery opening at the opposite end; feeding means connected to the charging opening arranged to maintain a substantially air tight connection therewith during the feeding of material to the drum to be disintegrated; pneumatic means having a substantial air-tight connection with the delivery openings adapted to draw air through the drum from the charging to the delivery opening; openings to the atmosphere with regulatable means in the connections of the feeding and pneumatic means with the drum to control the influx of air to and efflux of air from the drum; a separator connected to the delivery side of the pneumatic means having an outlet for the separated material and an air outlet; and a chamber having a screen wall connected to the air outlet of the separator and through the interstices of which screen the air is expelled to the atmosphere separating and collecting the dust from the air in the chamber.

3. In disintegrating apparatus, a disintegrating chamber having a charging opening and a delivery opening; feeding means connected to the charging opening arranged to maintain a substantially air tight connection therewith during the feeding of material to the drum to be disintegrated; pneumatic means connected to the delivery opening; regulatable means in the connections of the feeding and pneumatic means with the drum to control the influx of air to and the efflux of air from the drum; a separator connected to the delivery side of the pneumatic means having an outlet for the separated material and an air outlet; a chamber having a flexible screen wall connected to the air outlet of the separator and through the interstices of which screen wall the air is expelled from said chamber and separating dust from said air as it is expelled; outlet means from said chamber; and means to alternately flex and cause the wall of said chamber to be drawn taut to dislodge dust separated from the air and collected on the surface thereof to be delivered through the outlet means.

4. In disintegrating apparatus, a drum in which to disintegrate material having a charging opening and a delivery opening; suction means having air tight connection

with the delivery opening of the drum to draw air and disintegrated material from the drum and having an opening to the atmosphere with regulatable means to vary the size of said opening; a separator connected to the delivery side of said suction means having an outlet for the separated material and an air outlet; an air return pipe leading from the air outlet of the separator having an air tight connection with the charging opening of the drum; regulatable means in said return pipe operative to control the delivery of air from the separator to the drum and to shut off the delivery of air from the separator to the drum; a pipe leading from the air outlet of the separator to the connection of the fan with the drum; and regulatable means in the connection of said latter pipe to vary and shut off the connection thereof with the connection of the suction means with the drum.

5. In disintegrating apparatus, a drum in which to disintegrate material having a charging opening and a delivery opening; suction means having air tight connection with the delivery opening of the drum to draw air and disintegrated material from the drum; a separator connected to the delivery side of said suction means having an outlet for the separated material and an air outlet; an air return pipe leading from the air outlet of the separator having an air tight connection with the charging opening of the drum; regulatable means in said return pipe operative to control the delivery of air from the separator to the drum and to shut off the delivery of air from the separator to the drum; and regulatable means in the connection of the suction means with the drum operative to increase or decrease the suction from the drum while maintaining the delivery of the suction means constant for the purpose specified.

6. In disintegrating apparatus, a revoluble drum in which to disintegrate material having a charging opening and a discharge opening at opposite ends; pneumatic means connected to the discharge opening to draw air with disintegrated material from the drum; a separator connected to the delivery side of the pneumatic means having an outlet for the separated material and an air outlet; a chamber having a screen wall connected to the air outlet of the separator to expel the air to the atmosphere through the interstices of the screen, separating and collecting the dust from the air in the chamber; a return pipe leading from the air outlet of the separator to the charging opening of the drum; and regulatable means in the connections of the separator outlet with said pipe and chamber to control the connection of the air outlet of the separator with the charging opening of the drum and said screen chamber and to shut off the separator from said pipe and

screen chamber while maintaining the other open to the separator outlet.

7. In disintegrating apparatus, a disintegrating drum having a charging opening and a discharge opening; pneumatic means connected to the discharge opening to draw air with disintegrated material from the drum; a separator connected to the delivery side of the pneumatic means having an outlet for the separated material and an air outlet; a chamber having a screen wall connected to the air outlet of the separator to expel the air to the atmosphere through the interstices of the screen, separating and collecting the dust from the air in the chamber; outlet means from said chamber; means to flex the screen wall of the chamber to dislodge dust collected on the surface thereof to be delivered from the outlet means; and a return pipe leading from the air outlet of the separator to the charging opening of the drum.

8. In disintegrating apparatus, the combination with a drum in which to disintegrate material having a charging opening, a delivery opening and means to deliver material through the charging opening, of suction means having an air tight connection with the delivery opening of the drum to draw air and disintegrated material from the drum; a separator connected to the delivery side of the suction means having an outlet for the separated material and an air outlet; a chamber having a flexible screen wall connected to the air outlet of the separator to receive air from the separator and expel the same to the atmosphere through the interstices of the screen and separate the dust from the air as it is expelled; outlet means from said chamber; means to alternately flex and cause the wall of said chamber to be drawn taut to dislodge dust separated from the air and collected on the surface thereof to be delivered through the outlet means; a return pipe leading from the air outlet of the separator and having an air tight connection with the charging opening of the drum; regulatable means in said pipe operative to control the connection of said pipe with the separator and shut off the same from the separator; and regulatable means in the connections of the return pipe and suction means with the drum to control the influx of air to and efflux of air from the drum.

9. In disintegrating apparatus, the combination of a revoluble drum having charging and discharge openings and grinding means therein; pneumatic means connected to the discharge opening to draw air with disintegrated material from the drum; a separator connected to the delivery side of the pneumatic means having an outlet for the separated material and outlet means for the air; an air pipe leading from the separator to the connection of the pneumatic means with the

drum; and means to regulate the connection of the pneumatic means with the separator through said pipe and to shut off said connection from the separator.

5 10. In disintegrating apparatus, a revoluble drum in which to disintegrate material having a charging opening and a delivery opening; pneumatic means connected to the delivery opening to draw air through and with disintegrated material from the drum; 10 a separator connected to the delivery side of the pneumatic means having an outlet for the separated material and an air outlet; means to connect the air outlet of the separator with 15 the intake side of the pneumatic means; regulatable means in the connection of the pneumatic means with the drum to variably open the pneumatic means to the atmosphere to 20 impair the suction from the drum without impairing the lift of the air delivered by the pneumatic means; and regulatable means in the connection of the pneumatic means with the air outlet of the separator to vary said connection and shut off said connection.

25 11. In disintegrating apparatus, the combination of a revoluble drum having charging and discharge openings and grinding means therein; pneumatic means connected to the discharge opening to draw air with disintegrated material from the drum; a separator 30 connected to the delivery side of the pneumatic means having an outlet for the separated material and outlet means for the air; an air pipe leading from the separator 35 to the connection of the pneumatic means with the drum; a return pipe leading from the air outlet of the separator to the charging opening of the drum; and regulatable means to vary the connection of said pipes with the 40 air outlet of the separator and shut off either one or both of said connections.

45 12. In disintegrating apparatus, the combination of a revoluble drum having charging and discharge openings and grinding means therein; pneumatic means connected to the discharge opening to draw air with disintegrated material from the drum; a separator 50 connected to the delivery side of the pneumatic means having an outlet for the separated material and outlet means for the air; an air return pipe leading from the air outlet means of the separator to the connection 55 of the pneumatic means with the drum; an air return pipe leading from the air outlet means of the separator to the charging opening of the drum; regulatable means to vary the connection of said pipes with the air outlet of the separator and shut off either one or both of said connections; and regulatable means 60 in the connections of the return pipe with the charging opening of the drum and of the pneumatic means with the delivery opening of the drum to control the influx of air to and the efflux of air from the drum.

65 13. In disintegrating apparatus, the com-

70 bination of a revoluble drum having charging and discharge openings and grinding means therein; pneumatic means connected to the discharge opening to draw air with disintegrated material from the drum; a separator connected to the delivery side of the pneumatic means having an outlet for the 75 separated material and outlet means for the air; an air return pipe leading from the separator to the connection of the pneumatic means with the drum; a chamber having a flexible screen wall connected to the outlet means of the separator to receive air from the separator and expel the same to the atmosphere through the interstices of the screen 80 and separate and collect dust from the air in the chamber; outlet means from said chamber; and means to flex the wall of said chamber to dislodge dust collected on the surface thereof to be delivered through the outlet 85 means thereof.

14. In disintegrating apparatus, a disintegrating chamber having a charging opening and a delivery opening; feeding means connected to the charging opening arranged to 90 maintain a substantially air tight connection therewith during the feeding of material to the drum to be disintegrated; pneumatic means connected to the delivery opening; regulatable means in the connections of the 95 feeding and pneumatic means with the drum to control the influx of air to and efflux of air from the drum; a separator connected to the delivery side of the pneumatic means having an outlet for the separated material 100 and an air outlet; a return pipe leading from the separator to the intake of the pneumatic means having regulatable means therein to vary and shut off the connection between the separator and pneumatic means through said 105 return pipe; and a chamber having a screen wall connected to the air outlet of the separator and through the interstices of which screen wall air is expelled to the atmosphere 110 and separating and collecting dust from the air in said chamber.

15. In disintegrating apparatus, a drum in which to disintegrate material having a charging opening and a delivery opening; pneumatic means connected to the delivery 115 opening of the drum to draw air and disintegrated material from the drum; a separator connected to the delivery side of the pneumatic means having an outlet for the separated material and air outlet means; a chamber 120 connected to the outlet of the separator having outlet means; a tubular fabric member connected at the upper end to and suspended from the outlet means of the chamber and having closure means at the lower end, the air 125 being adapted to be expelled to the atmosphere through the interstices of the material of said member and dust separated from the air and collected on the surface of the tubular member, and means to alternately flex and 130

cause said member to be drawn taut to dislodge material separated from the air and collected on the surface of said member to be discharged through the outlet means.

5 16. Disintegrating apparatus as claimed in claim 15, wherein outlet means is connected to the lower end of said member in fixed spaced relation to the chamber, said fabric being of greater length than the space between the outlet means thereof and the chamber and being weighted intermediate its ends to normally draw the upper portion of the member taut; and means to lift the weighted portion of the tubular member and permit the same to draw the member taut to dislodge material separated from the air and collected on the surface thereof to be delivered through the outlet means.

17. Disintegrating apparatus as claimed in claim 15, wherein the outlet means is connected to the lower end of said member in fixed spaced relation to the chamber, said fabric member being of greater length than the space between the outlet means thereof and the chamber and being weighted intermediate its ends to normally draw the upper portion of the member taut; a vertically reciprocable frame adapted to alternately lift and permit the weighted portion of the fabric member to drop to alternately flex and draw said member taut to dislodge material from the air and collected on the surface thereof to be discharged through the outlet means; and means to vary and shut off the connection between said fabric member and the chamber.

18. Disintegrating apparatus as claimed in claim 15, wherein the chamber connected to the separator has a plurality of outlets with a tubular fabric member connected at the top to each of said outlets, and means to vary or shut off the connection between said fabric members and the chamber.

19. In disintegrating apparatus, a drum in which to disintegrate material having a charging opening and a delivery opening; pneumatic means connected to the delivery opening of the drum to draw air and disintegrated material from the drum; a separator connected to the delivery side of the pneumatic means having an outlet for separated material and air outlet means; a chamber connected to the outlet means of the separator having outlet means; tubular fabric members connected to the outlet means of said chamber and having outlet means; weights carried by said fabric members; and means to alternately lift said weighted portions and permit the same to drop to alternately flex and draw said fabric members taut to dislodge material collected on the surface thereof to be discharged through the outlet means.

20. Disintegrating apparatus as claimed in claim 15, wherein the chamber connected with the outlet of the separator has a plural-

ity of outlets with a tubular fabric member 65 connected to each chamber outlet with the lower ends weighted to maintain said member taut, a cam actuated reciprocatory frame to alternately lift said weighted portions of the members and permit the same to drop to alternately flex and draw said fabric members taut to dislodge material collected thereon to be discharged from the outlet means, and means arranged in the connection of each of said fabric members with the chamber outlet to vary or shut off the connection of either one or all of said fabric members with the chamber.

21. In disintegrating apparatus, a drum in which to disintegrate material, pneumatic means to draw air and disintegrated material from the drum; a separator connected to the delivery side of said pneumatic means having an outlet for the separated material and air outlet means; pipes leading from the outlet means of the separator to the intake of the pneumatic means and the charging opening of the drum; a chamber connected to the outlet means of the separator having a flexible screen wall to receive air from the separator and expel the same to the atmosphere through the interstices of the screen wall separating dust from the expelled air and collecting the same in said chamber, and said screen adapted to be flexed to dislodge material separated from the air and collected on the surface thereof; and regulatable means in said pipes and chamber to vary the connection or shut off either one or all of the pipes and chamber from the separator.

22. In disintegrating apparatus, the combination of a disintegrating drum, pneumatic means connected at the intake side thereof with the drum to deliver disintegrated material from the drum; a separator interposed in the connection of the pneumatic means and drum; adjustable means to connect said separator into the connection of the intake side of the pneumatic means with the drum and to shut off the separator from said connection while maintaining said connection of the pneumatic means with the drum; outlet means from the separator for coarse material separated from the air in its passage there-through; and means to open said separator to a variable extent to the atmosphere and shut off the same from the atmosphere.

23. In disintegrating apparatus, the combination of a disintegrating drum having charging and delivery openings, pneumatic means connected through the charging and delivery openings in circulatory connection with the drum, a separator interposed in the connection of the pneumatic means with the delivery opening of the drum, outlet means from the separator for material separated from the air in its passage therethrough from the drum; and an adjustable connection be-

tween said outlet means and separator adapted to open the separator to the atmosphere through said connection.

24. In disintegrating apparatus, the combination of a revoluble drum arranged with charging and delivery openings axially at opposite ends and having freely moving grinding elements therein operative through the revolving of the drum to render the material into an impalpable fine state, pneumatic suction means connected through the charging and delivery openings in circulatory connection with the drum to draw air with disintegrated material therefrom, a separator interposed in the connection of the pneumatic suction means with the delivery opening of the drum and having outlet means for material separated from the air from the drum in its passage through the separator, and an opening to the atmosphere in the connection of the pneumatic suction means with the drum arranged with regulatable means to vary the area of said opening to the atmosphere.

25. In disintegrating apparatus, the combination of a revoluble drum having charging and delivery openings, a fan connected through the charging and delivery openings in circulatory connection with the drum to draw air with disintegrated material therefrom, a separator interposed in the connection of the fan with the delivery opening of the drum, means to connect the fan with the drum through the separator and to shut off the separator from the connection of the fan and drum while maintaining said connection between the fan with the drum, outlet means from the separator for material separated from the air in its passage therethrough from the drum and an opening to the atmosphere in the connection of the fan with the delivery opening of the drum arranged with regulatable means to vary the area of said opening.

26. In disintegrating apparatus, the combination of a disintegrating drum having charging and delivery openings, a fan connected at the intake side thereof with the delivery openings of the drum to draw air with disintegrated material therefrom, a separator interposed in the connection of the fan with the delivery opening of the drum, a separator connected at the delivery side of the fan having an air outlet, and an air return pipe connected to the air outlet of the latter separator and the connection of the fan with the delivery opening of the drum.

27. In disintegrating apparatus, the combination of a disintegrating drum having charging and delivery openings, a fan connected at the intake side thereof with the delivery opening of the drum to draw air with disintegrated material therefrom, a separator interposed in the connection of the fan with the delivery opening of the drum, a separator connected at the delivery side of the

fan having an air outlet, an air return pipe connected to the air outlet of the latter separator and the connection of the fan with the delivery opening of the drum, and regulatable means in said air return pipe to shut off said pipe from and vary the connection thereof with said fan connection to the drum.

28. In disintegrating apparatus, the combination of a disintegrating drum having charging and delivery openings, a fan connected at the intake side with the delivery opening of the drum to draw air with disintegrated material from the drum, a separator, means to connect said separator into the connection of the fan with the delivery opening of the drum and shut off said separator from said connection while maintaining said connection of the fan with the drum, outlet means from said separator for material separated from the air in its passage through the separator, a separator connected to the outlet side of the fan having an outlet for the material separated from the air discharge into the separator by the fan and having an air outlet, an air return pipe connected to the air outlet of said latter separator and leading to the connection of the fan with the delivery opening of the drum, regulatable means in said pipe to shut off the pipe from and vary the connection thereof with the connection of the fan to the delivery opening of the drum, and an opening to the atmosphere in the connection of the fan with the delivery opening of the drum arranged with regulatable means to vary the area of said opening.

29. In disintegrating apparatus, the combination of a disintegrating drum having charging and delivery openings, a fan connected at the intake side thereof with the delivery opening of the drum to draw air with disintegrated material therefrom, a separator interposed in said connection of the fan with the drum, a separator connected at the delivery side of the fan having an air outlet, an air return pipe connected to the air outlet of the latter separator and the connection of the fan with the delivery opening of the drum and a pipe leading from the air outlet of the second separator to the charging opening of the drum.

30. In disintegrating apparatus, the combination of a disintegrating drum having charging and delivery openings, a fan connected at the intake side thereof with the delivery opening of the drum to draw air with disintegrated material therefrom, a separator interposed in said connection of the fan with the drum, a separator connected at the delivery side of the fan having an air outlet, an air return pipe connected to the air outlet of the latter separator and the connection of the fan with the delivery opening of the drum, a pipe leading from the air outlet of the second separator to the charging opening of the

drum, and means to vary and shut off the delivery of air from said separator through either one or both of said pipes or deliver air through both of said pipes.

5 31. In disintegrating apparatus, a revoluble drum in which to disintegrate material having charging and delivery openings, pneumatic suction means connected with the
 10 delivery opening of the drum, a separator connected to the delivery side of the pneumatic suction means having an outlet for the separated material and an air outlet, pipes leading from the air outlet of the separator to the
 15 charging opening of the drum and to the connection of the pneumatic suction means with the delivery opening of the drum, regulatable means in said pipes to vary and shut off the connections of said pipes with the charging opening of the drum and the connection
 20 of the pneumatic suction means with the drum, and regulatable means for variably opening the intake of the pneumatic suction means and drum to the atmosphere to control the velocity of the flow of air through the
 25 drum and thereby the drawing off of pulver-

ized material of variable fineness from the drum.

32. In disintegrating apparatus, the combination of a revoluble drum arranged with charging and delivery openings and having
 30 means therein operative through the revolving of the drum to render material in the drum into an impalpable fine state, pneumatic suction means connected in circulation
 35 with the charging and delivery openings of the drum to air sweep the drum and draw disintegrated material therefrom, a separator interposed in the connection of the pneumatic suction means with the delivery of the
 40 drum having an outlet for material separated from the air and air inlet means from the atmosphere outside of the circulatory connection with the drum, and adjustable means to open said air inlet means to the atmosphere and shut the same off from the atmosphere.
 45

Signed at New York city in the county of New York and State of New York, this 14th day of March, 1924.

JOSEPH E. KENNEDY.