

July 31, 1923

1,463,733

R. J. TURNER

DESK ORGANIZER

Filed Sept. 8, 1921

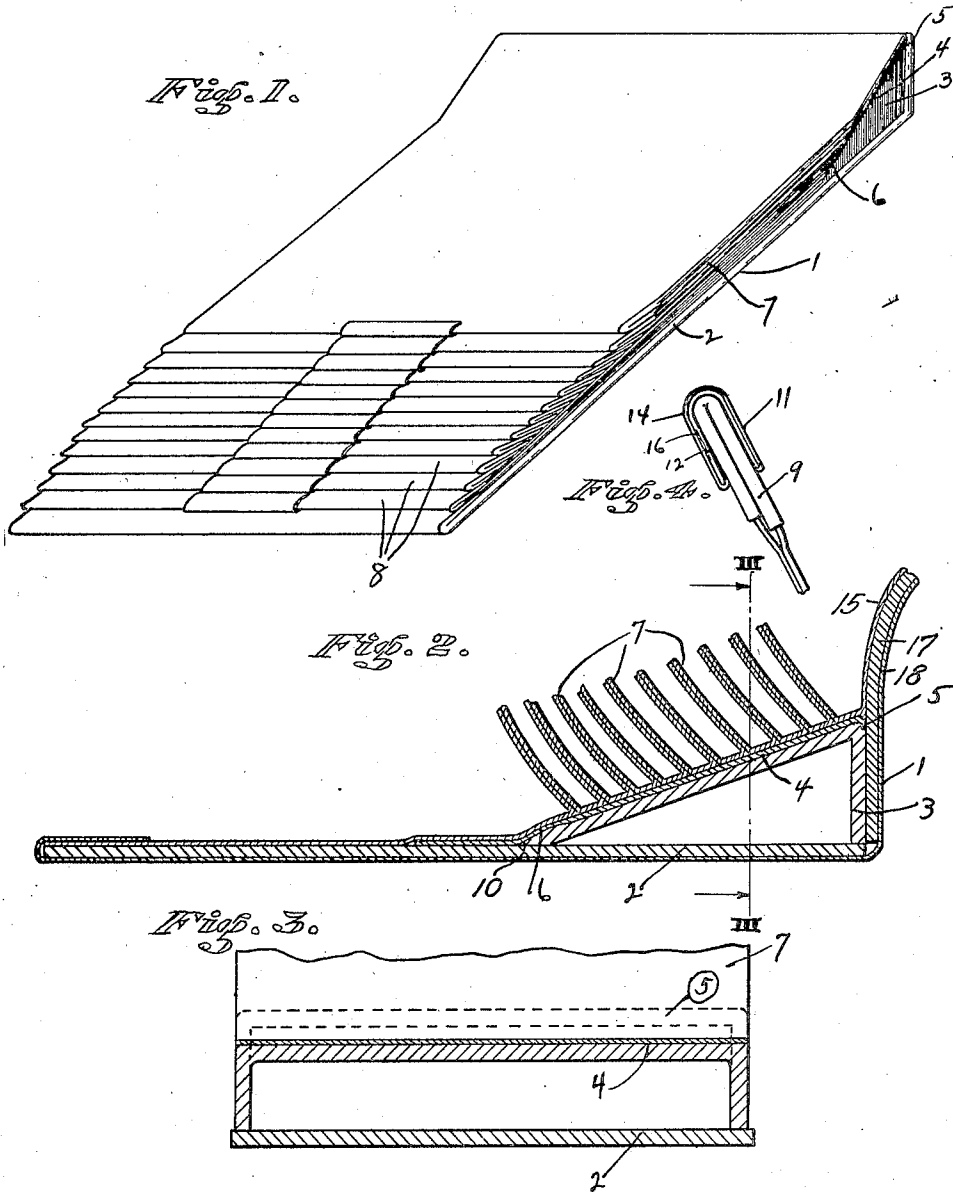

Inventor  
R. J. TURNER

*Handwritten signature*  
Attorneys.

# UNITED STATES PATENT OFFICE.

ROY J. TURNER, OF SAN FRANCISCO, CALIFORNIA, ASSIGNOR TO EFFICIENCY FILE CO., A COPARTNERSHIP, OF CHICAGO, ILLINOIS.

## DESK ORGANIZER.

Application filed September 8, 1921. Serial No. 499,223.

*To all whom it may concern:*

Be it known that I, ROY J. TURNER, a citizen of the United States, and resident of San Francisco, county of San Francisco, and State of California, have invented a new and useful Desk Organizer, of which the following is a specification.

The present invention relates to improvements in desk organizers and its particular object is to provide a convenient means for receiving, in classified order various papers and letters such as ordinarily gather on the desk of a business man. Such organizers have been used before, but my invention discloses a new construction for the same which makes it particularly adapted to hold a plurality of papers without losing its shape and without assuming a bulky appearance.

The preferred form of my invention is illustrated in the accompanying drawing, in which Figure 1 is a perspective view of my desk organizer, Figure 2 a longitudinal cross-section through the same, Figure 3 a transverse cross-section along line 3—3 of Figure 2 and Figure 4 an enlarged detail side view of the lower end of one of the leaves forming a part of my device.

Referring to the drawings in detail it will be seen that my desk organizer (1) comprises the base (2), which latter is a preferably rectangular plate of preferably semi-flexible material such as carboard. A block (3) having a slanting surface (4) is secured on the base at one end of the same in such manner that the highest edge (5) of the block runs along the border of the plate and the slanting surface descends on the base so as to run into the same as at (10). The block is preferably made of cardboard and hollow so as not to unduly increase the weight of the device.

To the block a plurality of leaves (7) are secured in ascending relation as shown in the drawing. The leaves are of flexible material and are in width co-extensive with the base, while longitudinally they are arranged in such manner that each lower leaf extends, at its loose end, slightly beyond the leaf next above it, so that a marginal edge

(8) of the same remains exposed to the eye. A very convenient way of securing the leaves to the block is illustrated in the drawing and it consists in placing one end of a long strip of flexible material (6), as strong paper for instance, against the upper edge (5) of the block (3) and leading it down the inclined surface of the block so as to pass the joint between the latter and the base. Starting then at the opposite end of the base, the paper is carried to the lower edge of the block (3) secured there, preferably by gluing it, turned on itself and lead to within close proximity of the opposite edge, turned on itself again to be secured to a somewhat higher place on the inclined plane of the block, and so forth, until a desired number of leaves has been placed and the top of the block has been reached. The uppermost leaf (15) is preferably single and lies against a cover (17) of more substantial material, such as leather or composition, the latter having a surface covering 18 which is carried around the block and the base so as to lend to the device a pleasing appearance.

It will be seen that in this manner each leaf of the device comprises a double sheet and the free end of each leaf is fortified by a strip of covering material as shown at (9) which is bent over the edge lengthwise and turned under at the ends so as to present a smooth appearance. These fortifying strips furnish a convenient hold for the clasps (11) which are clamped around a central portion of the free end of each leaf and consist of a metal U-shaped clamp (12) surrounded by a similar shaped strip (14) of transparent material such as celluloid and having a strip (16) of paper carrying some indicating mark slipped between them.

I wish to have it understood that I do not desire to limit myself to all the details of the construction and that slight deviations and modifications may be made without affecting the spirit of the invention.

I claim:

A desk organizer comprising a rigid base plate, a block mounted at one end of the same having a slanting upper surface de-

ascending toward the base frame; a strip of flexible material secured to the lower end of the block surface and alternately led away from and back to the block so as to form a plurality of double leaves secured to the block in ascending and spaced relation with the leaves made of substantially equal size so as to present a correspondingly inclined formation at the opposite end, and a cover of relatively stronger material than the leaves secured to the back of the block and adapted to overlie the upper leaf. 10

ROY J. TURNER.