



US00D662000S

(12) **United States Design Patent**  
**Ross, Jr. et al.**

(10) **Patent No.:** **US D662,000 S**

(45) **Date of Patent:** **\*\* Jun. 19, 2012**

(54) **LIQUID LEVEL GAUGE**

*Primary Examiner* — Antoine D Davis

(74) *Attorney, Agent, or Firm* — Alvin R. Wirthlin

(75) Inventors: **Herbert G. Ross, Jr.**, Argyle, TX (US);  
**Gagik Farmanyany**, Plano, TX (US)

(73) Assignee: **Rochester Gauges, Inc.**, Dallas, TX (US)

(57) **CLAIM**

The ornamental design for a liquid level gauge, as shown and described.

(\*\*) Term: **14 Years**

**DESCRIPTION**

(21) Appl. No.: **29/380,010**

(22) Filed: **Nov. 29, 2010**

(51) **LOC (9) Cl.** ..... **10-04**

(52) **U.S. Cl.** ..... **D10/101**

(58) **Field of Classification Search** ..... D10/101;  
73/1.73, 149, 290 V, 290 R, 293, 304 R, 304 C,  
73/305, 313, 314, 317, 865.9

See application file for complete search history.

(56) **References Cited**

U.S. PATENT DOCUMENTS

3,470,907 A	10/1969	Shockey	
4,641,122 A	2/1987	Hennequin	
4,972,875 A	11/1990	Beer et al.	
RE34,679 E	8/1994	Ritzenthaler et al.	
5,762,049 A	6/1998	Jones et al.	
D611,859 S	3/2010	Gismervik	
D611,860 S *	3/2010	Gismervik	..... D10/101

\* cited by examiner

FIG. 1 is an isometric view of a liquid level gauge showing my new design;

FIG. 2 is a rear elevational view thereof;

FIG. 3 is a front elevational view thereof;

FIG. 4 is a right side elevational view thereof;

FIG. 5 is a left side elevational view thereof;

FIG. 6 is a top plan view thereof;

FIG. 7 is a bottom plan view thereof.

FIG. 8 is an isometric view of a liquid level gauge showing another embodiment of my new design;

FIG. 9 is a rear elevational view thereof;

FIG. 10 is a front elevational view thereof;

FIG. 11 is a right side elevational view thereof;

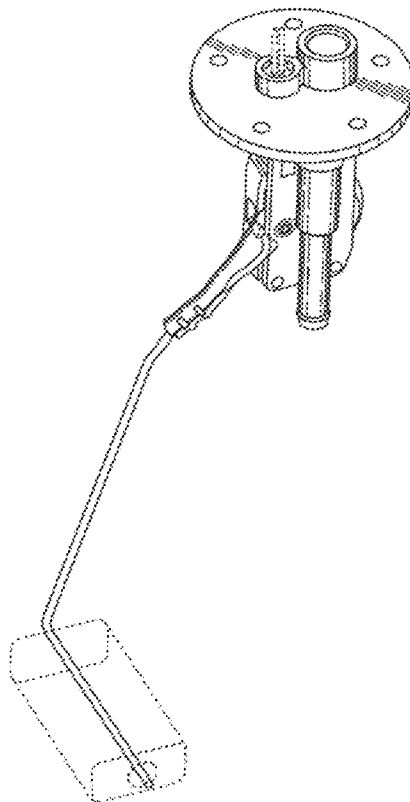
FIG. 12 is a left side elevational view thereof;

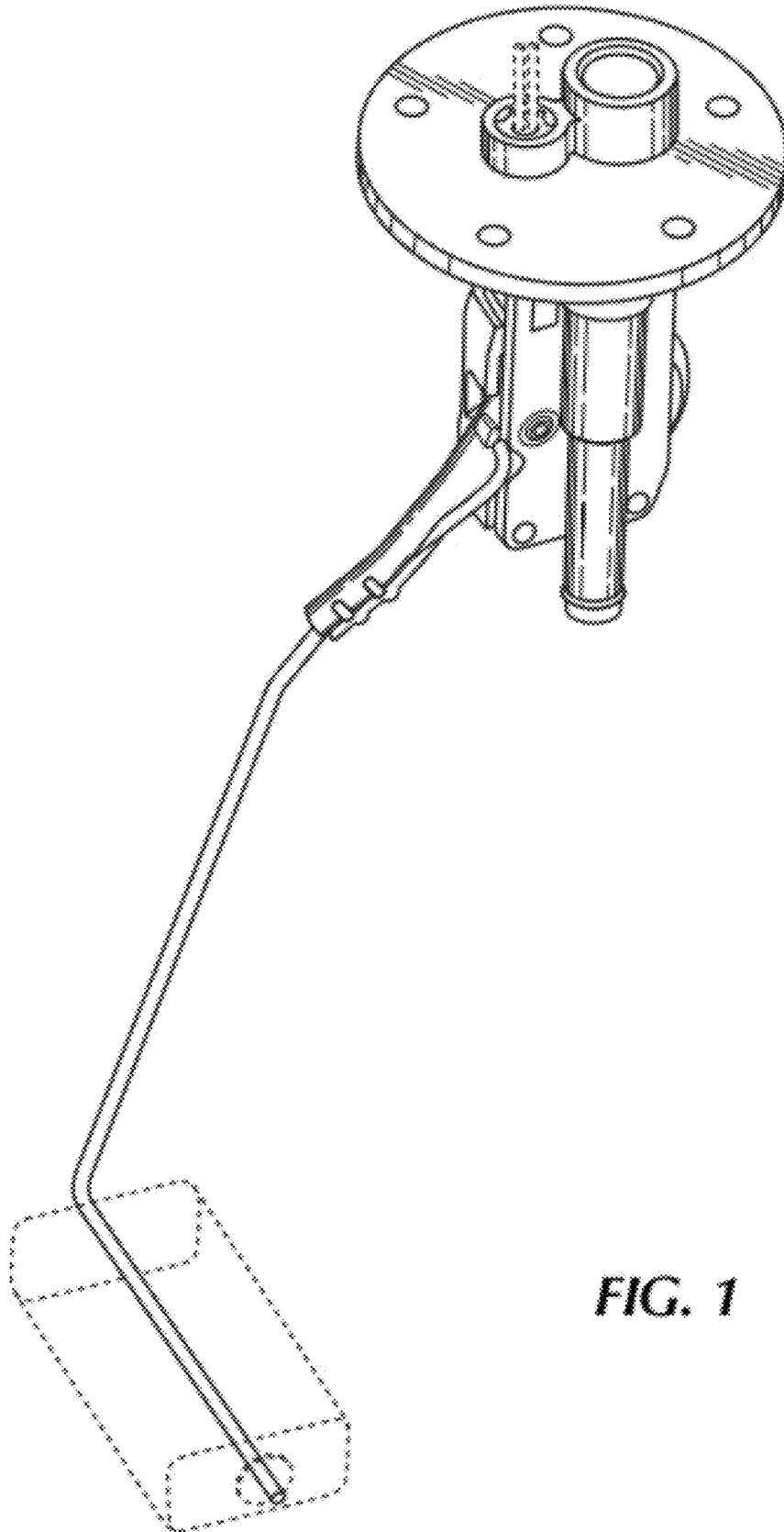
FIG. 13 is a top plan view thereof; and,

FIG. 14 is a bottom plan view thereof.

The broken lines shown on the drawings represent unclaimed portions of the design and form no part thereof.

**1 Claim, 10 Drawing Sheets**





**FIG. 1**

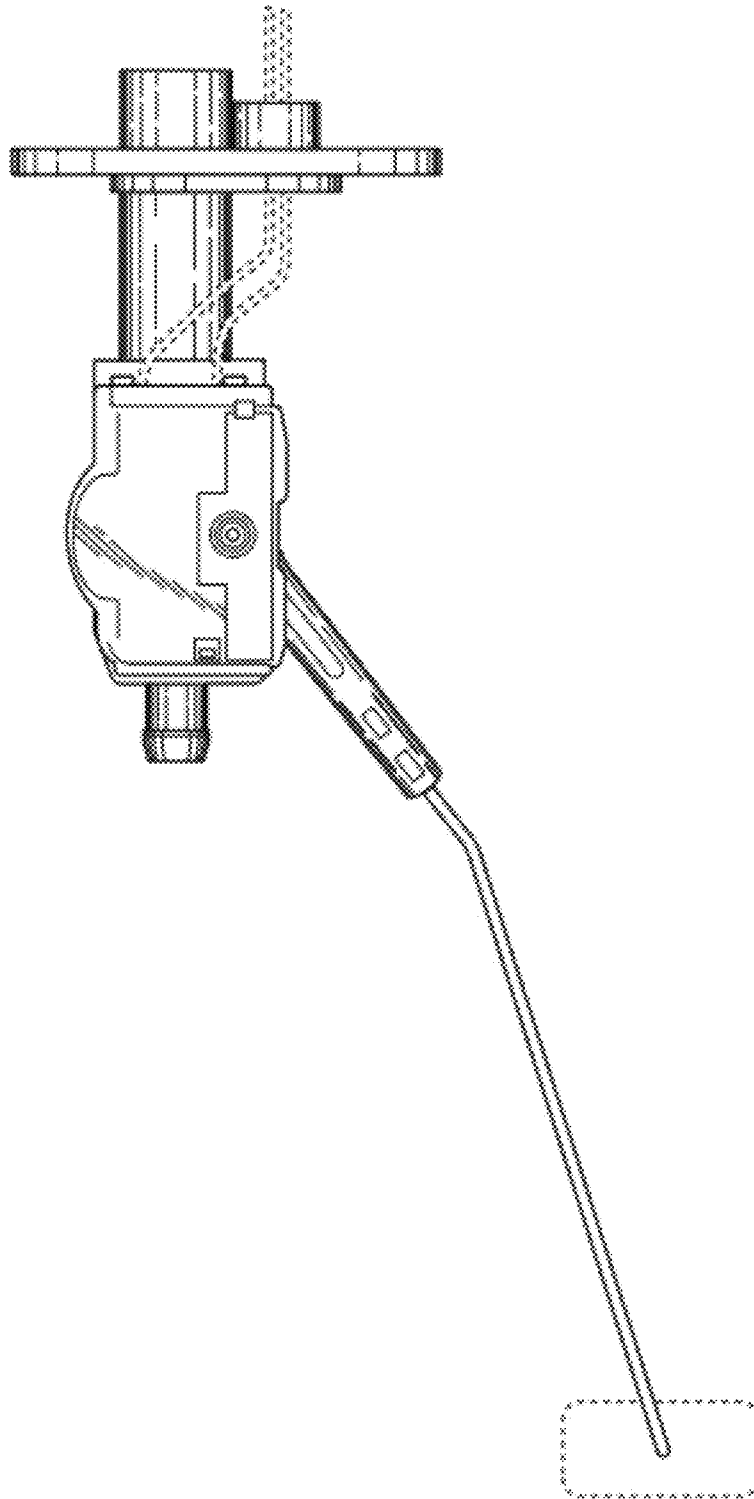


FIG. 2

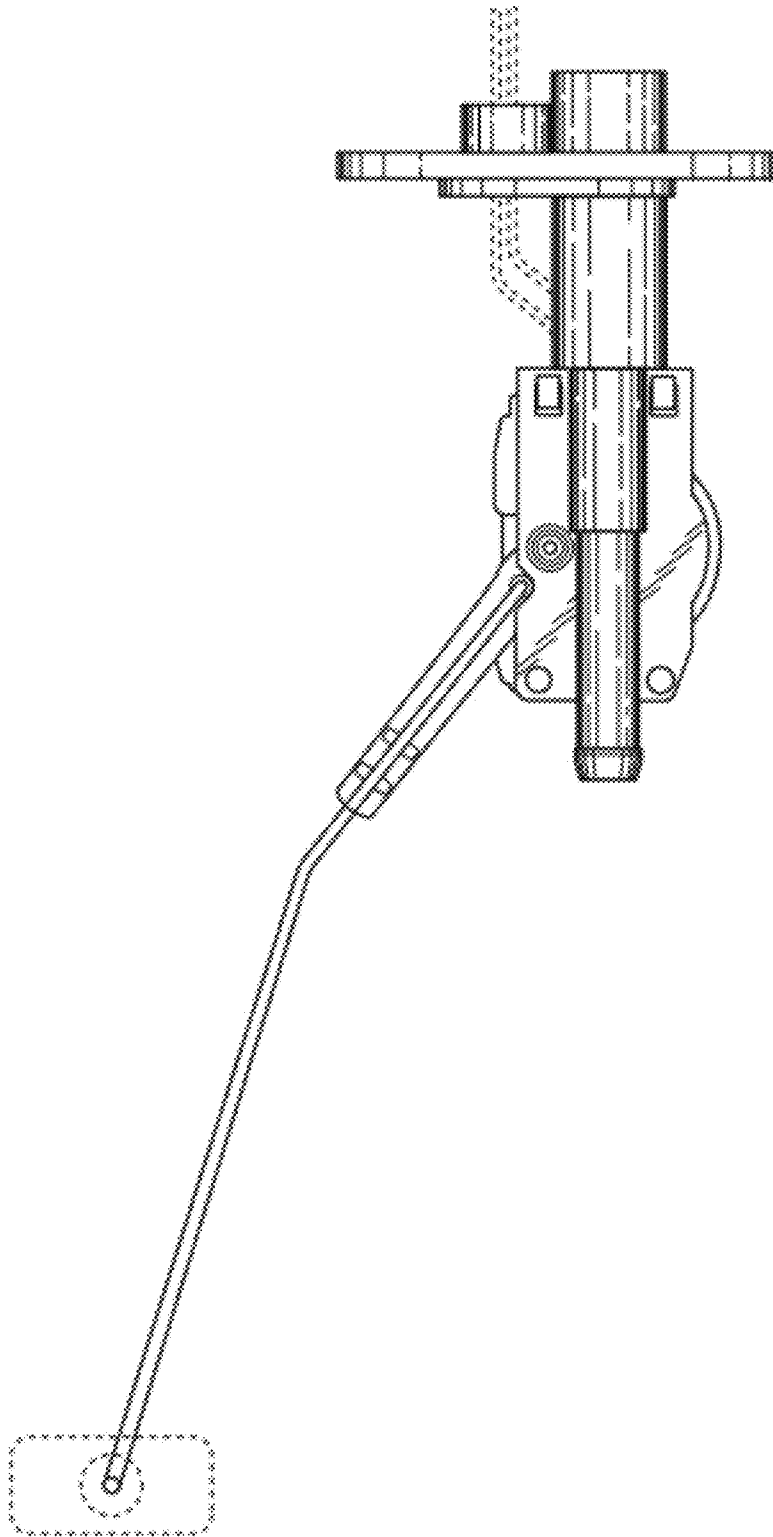


FIG. 3

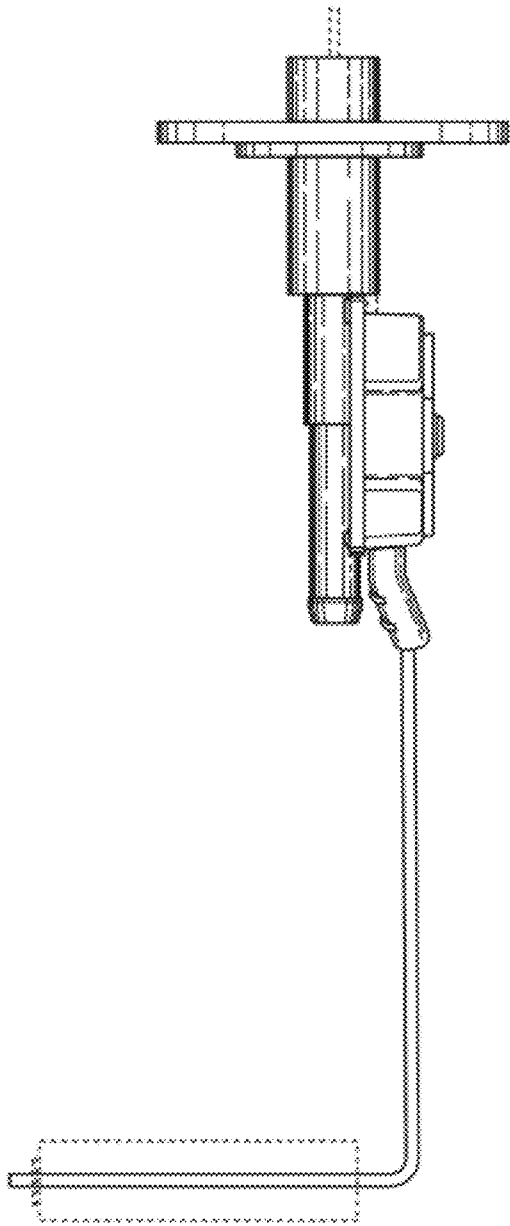


FIG. 4

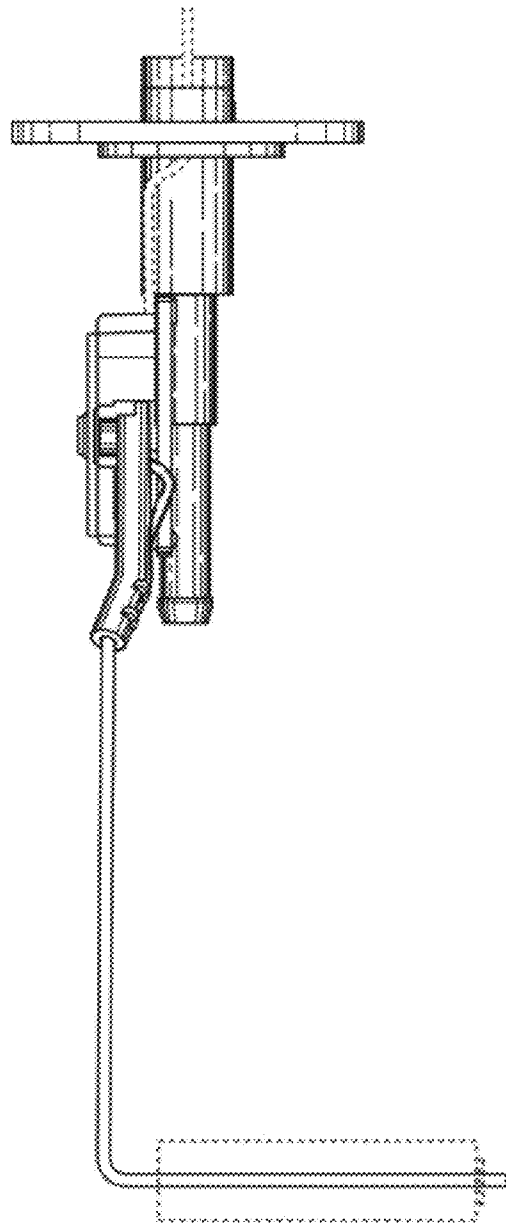


FIG. 5

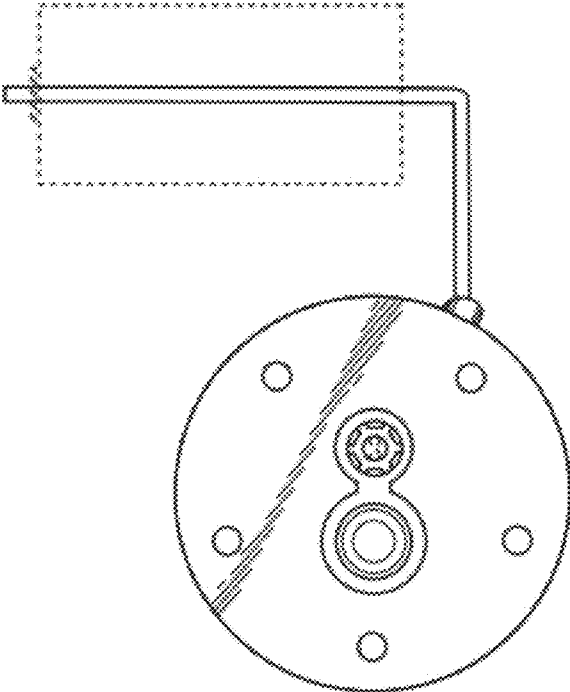
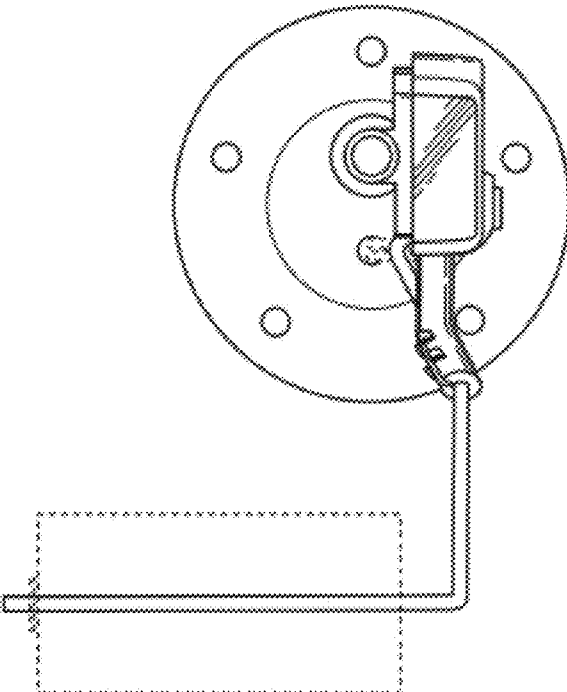
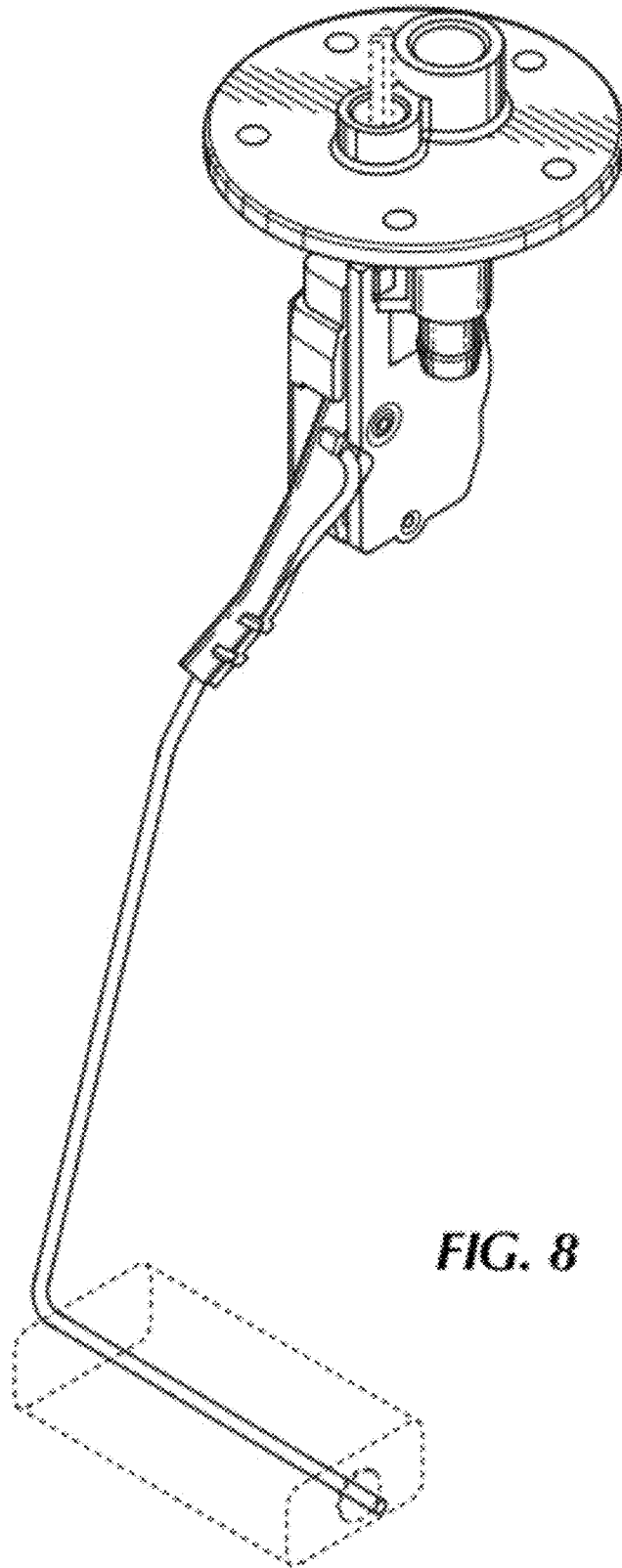


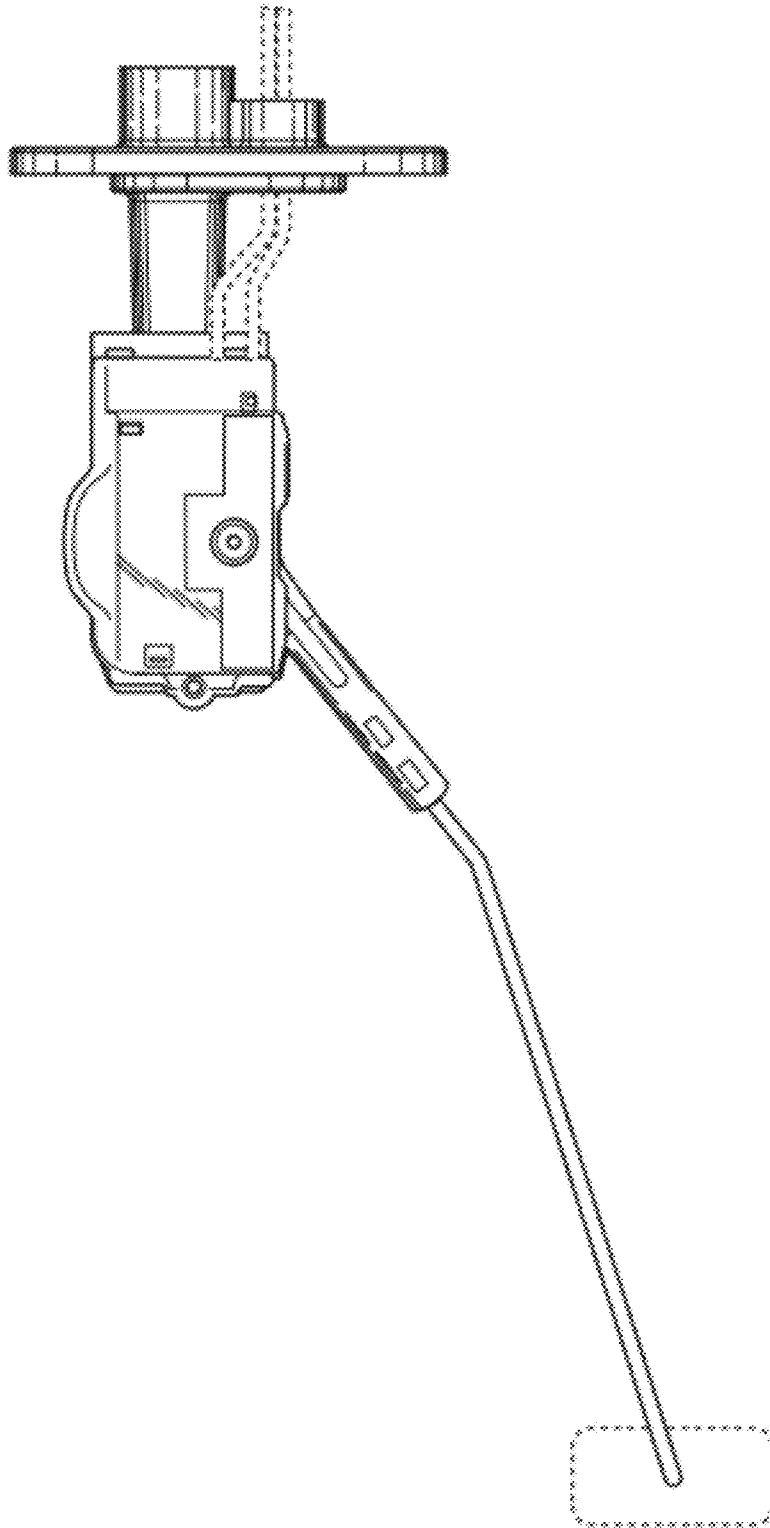
FIG. 6

FIG. 7

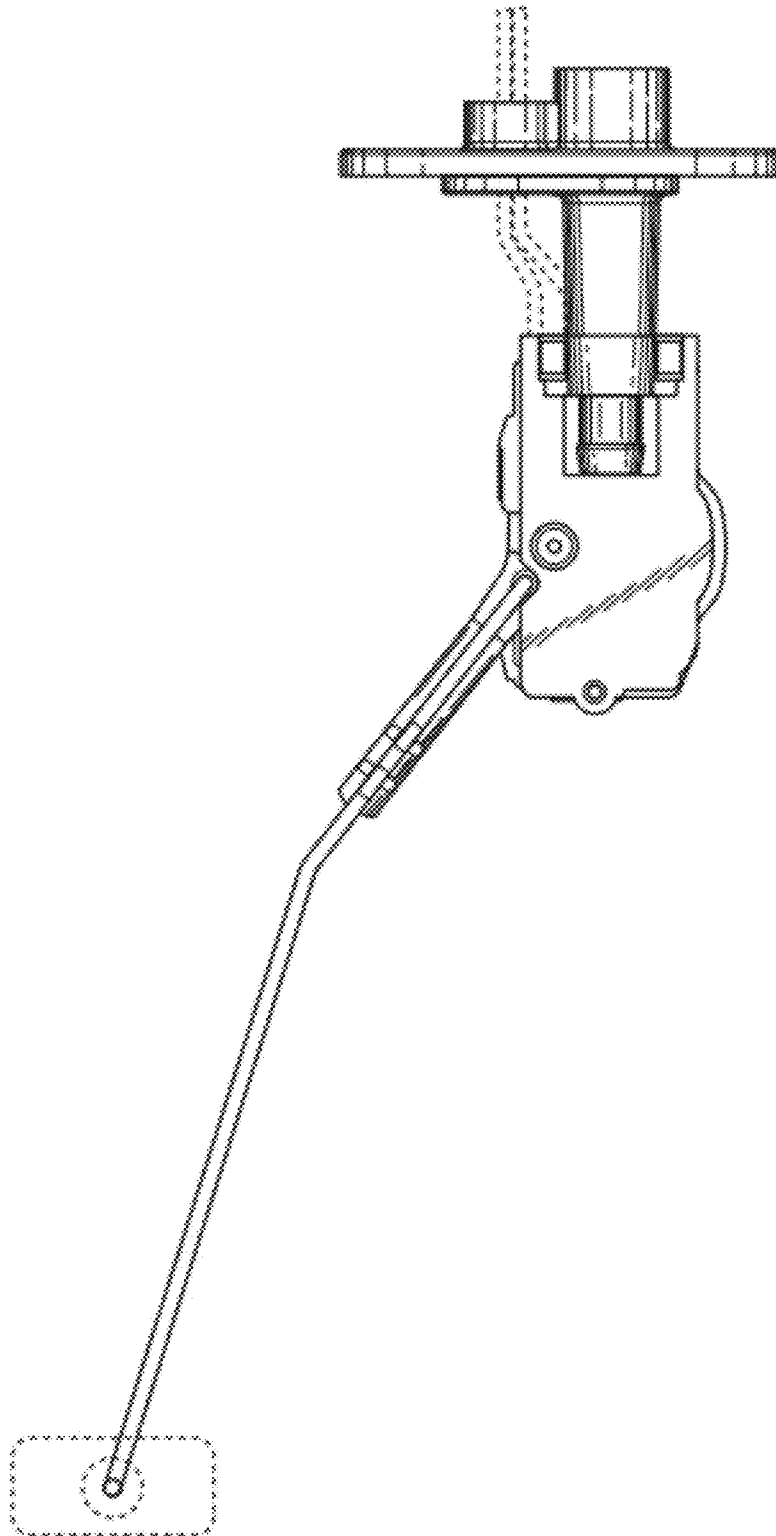




**FIG. 8**



**FIG. 9**



**FIG. 10**

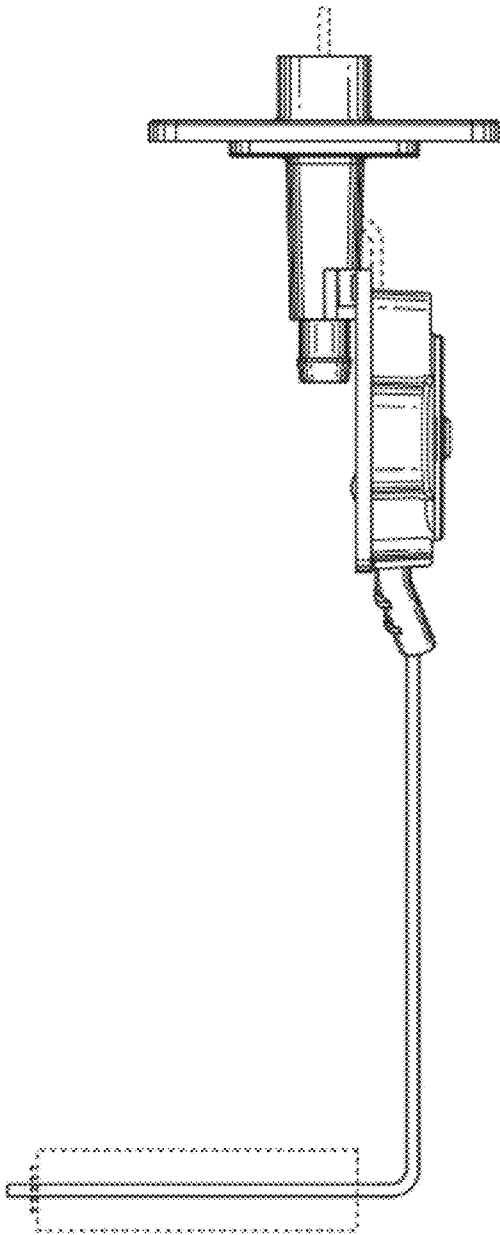


FIG. 11

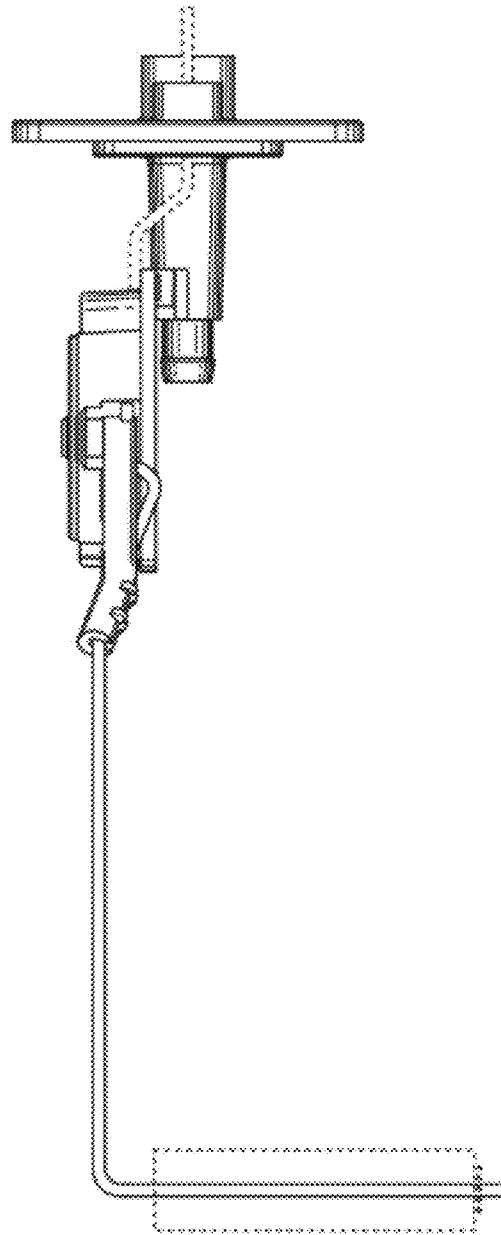


FIG. 12

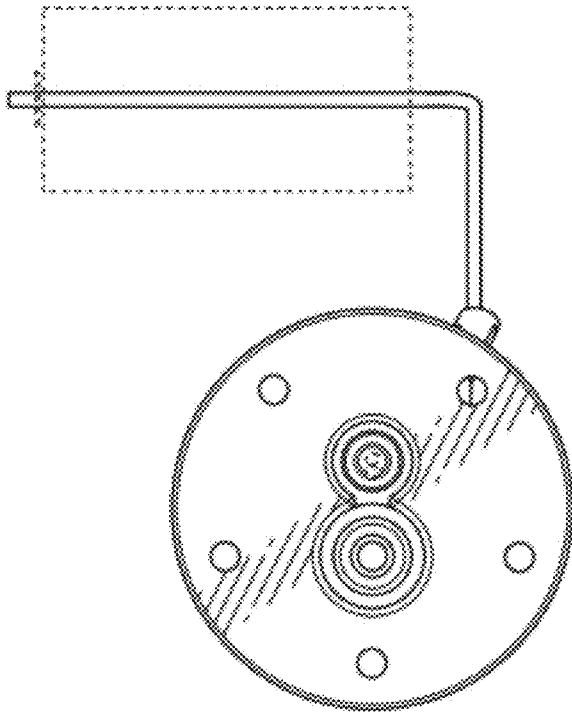


FIG. 13

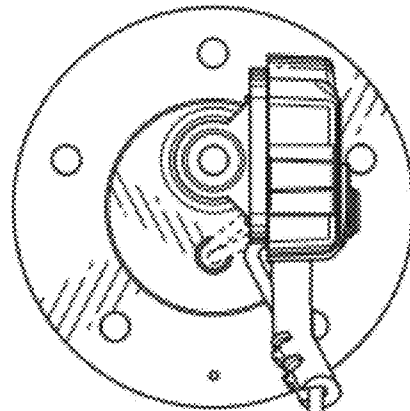


FIG. 14