

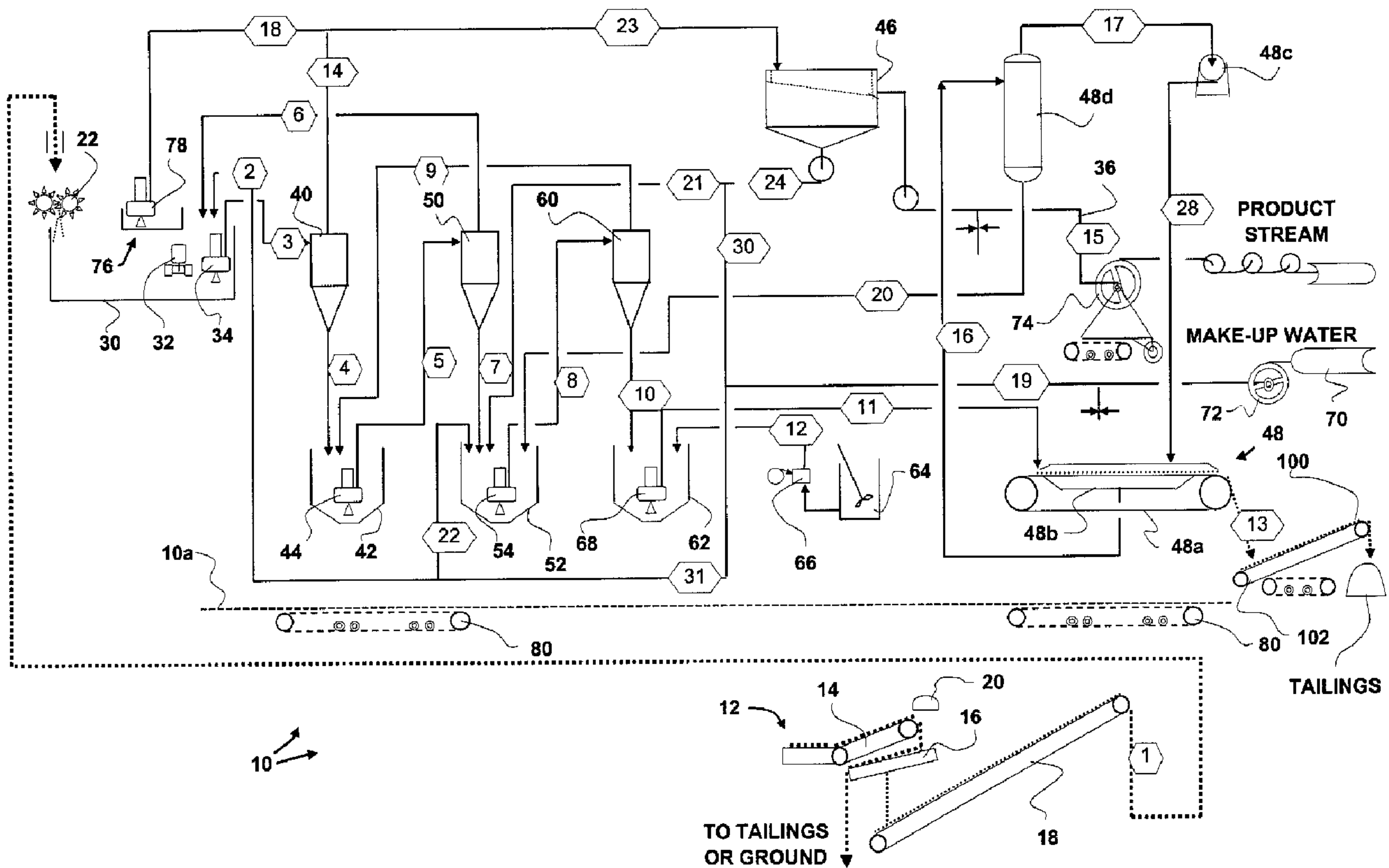

(22) Date de dépôt/Filing Date: 2001/01/24  
 (41) Mise à la disp. pub./Open to Public Insp.: 2001/10/14  
 (45) Date de délivrance/Issue Date: 2003/02/11  
 (62) Demande originale/Original Application: 2 332 207  
 (30) Priorité/Priority: 2000/08/04 (2,315,596) CA

(51) Cl.Int.<sup>7</sup>/Int.Cl.<sup>7</sup> E21C 41/26  
 (72) Inventeurs/Inventors:  
 LAVENDER, WILLIAM J., CA;  
 KAETHLER, HARRY, CA  
 (73) Propriétaire/Owner:  
 TSC COMPANY LTD., CA  
 (74) Agent: MCCARTHY TETRAULT LLP

(54) Titre : PROCEDE ET APPAREIL AFIN DE RECOUVRIR UN PRODUIT ENRICHI D'HUILE PROVENANT D'UN  
 MATERIEL PETROLIFERE  
 (54) Title: PROCESS AND APPARATUS FOR RECOVERING AN OIL-ENRICHED PRODUCT FROM AN OIL-BEARING  
 MATERIAL



(57) Abrégé/Abstract:

The apparatus and the process are used for recovering an oil-enriched product from oil-bearing material or materials, such as tar sands. The oil-bearing material is mined using a mining equipment and is sent into the apparatus where an optimum amount of oil-enriched product is removed therefrom. Unlike conventional technologies, only a relatively small amount of solvent is used

**(57) Abrégé(suite)/Abstract(continued):**

and most of it is recycled back into an earlier stage of the process. The process does not need a tailings pond since the tailings are substantially dewatered at the end of the process. Further, the tailings are deposited in an adjacent area once they come out of the apparatus. This significantly reduces the material handling and transport undertaking, thereby allowing the process and the apparatus to be operated at substantially lower costs compared to conventional technologies.

## ABSTRACT

The apparatus and the process are used for recovering an oil-enriched product from oil-bearing material or materials, such as tar sands. The oil-bearing material is mined using a mining equipment and is sent into the apparatus where an optimum amount of oil-enriched product is removed therefrom. Unlike conventional technologies, only a relatively small amount of solvent is used and most of it is recycled back into an earlier stage of the process. The process does not need a tailings pond since the tailings are substantially dewatered at the end of the process. Further, the tailings are deposited in an adjacent area once they come out of the apparatus. This significantly reduces the material handling and transport undertaking, thereby allowing the process and the apparatus to be operated at substantially lower costs compared to conventional technologies.

**PROCESS AND APPARATUS FOR RECOVERING AN  
OIL-ENRICHED PRODUCT FROM AN OIL-BEARING MATERIAL**

This is a division of Canadian Patent Application No. 2,332,207 filed 24 January 2001.

5 Tar sands are deposits of loose sand or partially consolidated sandstone which are saturated with highly viscous bitumen. Tar sand is a common form of oil-bearing material. It is also sometimes called bituminous sand or oil sand. The world's largest known deposits of tar sands are located in Canada on the banks of the Athabasca River in northeastern Alberta. The Athabasca tar sands are estimated  
10 to contain some 300 billion barrels of bitumen heavy oil. Of this total, it is estimated that some 80 billion barrels are accessible for recovery through surface mining methods.

Oil produced from the bitumen in tar sands is commonly referred to as synthetic crude oil. The only commercial projects for synthetic oil production from tar sands  
15 are being carried out in the Athabasca region. A project for a typical 100,000 barrel per day bitumen production facility is currently estimated to cost over 1 billion dollars to build using conventional technologies. Such a project would also cost over \$5 dollars per barrel to operate and would have significant environmental impacts.

20 Conventional technologies presently used for commercial operation of bitumen recovery from tar sand were developed in the mid-sixties and, until now, have not changed dramatically. They currently involve surface mining to extract thick tar sand deposits found near the surface. Before the actual mining operations begin, the mine area is dewatered and overburden is removed from its surface. Earth  
25 moving equipment is used to strip and stockpile the overburden. The overburden will be later removed and disposed of with the same equipment. Meanwhile, construction of tailings pond starter dikes is undertaken using appropriate stripped

overburden. Excavation was traditionally achieved using a bucketwheel or drag line excavation method. More recently, large shovels and trucks are used. Heavy truck haul roads for the transport of overburden and tar sand ore are constructed, often employing scarce granular resources. The mining of tar sand ore can begin afterwards. After mining, the tar sand ore is hauled to a preparation facility where it is typically crushed and mixed with water to form a slurry. The slurry is then pumped into pipelines and sent to a central processing plant.

Generally, a conventional processing plant removes bitumen from the slurry using a bitumen flotation method. Such method involves using hot water for slurring. Bitumen froth is floated by way of thickener type vessels and air induced flotation cells. The bitumen froth contains a concentrated amount of bitumen. This oil-enriched product is sent to another plant where it will be upgraded to synthetic crude oil.

Since the bitumen is typically only about 7 to 12% of the total ore mass removed from the mine face, tailings are produced and are transported in massive quantities throughout the process. In conventional recovery operations, these tailings are ultimately transported out of the processing plant by hydro-transport methods and disposed in immense tailing ponds, where the fine suspended solids are allowed to settle by gravity. Over the ensuing years, fine particles in the water settle to a point where water can be removed and the solids sludge from the tailing ponds can be rehandled and mixed with coarse tailings in the manufacture of consolidated tailings. It is only then that tailing ponds can be remediated and eventually reforested. Meanwhile, tailing pond dikes need to be continuously constructed since the process generates waste products faster than the settling rate in the tailings ponds can clarify.

Conventional recovery technologies thus have many drawbacks. One of the major ones is that they require transport of massive quantities of materials such as tailings, tar sand ore and water over very long distances. Tailings ponds also have

a major impact on the environment and are a concern to governments and the public.

Operating a conventional recovery process is very costly because of all the required transport equipment, support facilities, apparatuses, personnel and  
5 energy required to undertake all tasks. As a result, the recovery of bitumen from tar sand ore is a risky venture because profits can be easily offset by the very large fixed and variable operating costs. Projects are viable only when the price of crude oil is relatively high.

Overall, conventional technologies for mining and exploiting deposits of oil-bearing  
10 materials are limited in their applicability, environmental acceptability, cost and therefore, in their overall efficacy.

The present invention is concerned with providing a suitable alternative to conventional technologies and applies to various oil-bearing materials, such as tar sand.

15 The present invention will now be described with references to the appended figures, in which:

FIG. 1 is a schematic diagram showing an example of the process in accordance with a possible embodiment of the present invention.

FIG. 2 is a side elevation view of the exterior of an apparatus in accordance with a  
20 possible embodiment.

FIG.3 is a side elevation view showing the interior of the apparatus of FIG. 2.

FIG. 4 is a top view taken along line 4-4 in FIG. 3.

Referring to FIG. 1, there is shown an example of a process according to a preferred and possible embodiment. It should be noted that the reference numerals in the hexagons refer only to a stream number for Table 1 at the end of the present description. The numerals outside the hexagons are the reference numerals used throughout the present description.

The present invention is used for recovering an oil-enriched product from oil-bearing material or materials, such as tar sand. The oil-enriched product is in particular bitumen. Preferably, the oil-bearing material is extracted using an open pit technique, whereby the material is mined with suitable mining equipment in an opened mine area. The mine area is previously prepared, which involves known tasks such as mine dewatering, muskeg removal and stacking for future use, and overburden stripping and storage for later re-deposition in the mine face (M), whenever appropriate.

The process of FIG. 1 is preferably carried in a mobile or semi-mobile (relocatable) apparatus (10), such as the one shown in FIGS. 2 to 4. This apparatus (10) may comprise one or more supporting platforms (10a), or transporter units, on which are mounted the components required to carry out the recovery process. For example, the crushing and slurring, the separation, the filtration and the tailings stacking segments can each or in combinations be mounted on separate transporter units. The mining can also be done using mining equipment mounted on the apparatus itself, either alone on a separate transporter unit or in combination with other components. However, most of these elements are preferably enclosed in a space above a single platform (10a). It should be noted that the illustrated apparatus (10) is only one possible example and other embodiments are possible. The apparatus (10) can also be fixed.

Once mined, the oil-bearing material is preferably carried inside the apparatus (10) through a material inlet (12) using a first conveyor (14). In the apparatus (10)

illustrated in FIGS. 2 to 10, the first conveyor (14) is preferably a pan conveyor. Other means are also possible as well.

Referring back to FIG. 1, the oil-bearing material is preferably discharged at the end of the first conveyor (14) over a screen (16), preferably a scalping grizzly or any suitable equivalent, in order to remove oversized ore lumps. If necessary, these oversized ore lumps could be fed into a crusher to reduce their size under the maximum limit required for slurring. Alternatively, they can be dropped on the ground beneath the apparatus (10) or even bypassed and added directly to the tailings that are produced at the end of the process. Similarly, the material can be diverted to the tailings using a bypass path, such as a chute, when they are not suitable for processing. This would be the case if, for example, oil is not present in worthwhile quantities.

Also in FIG.1, the oil-bearing material that has passed through the screen (16) preferably falls onto a second conveyor (18), more preferably a pipe conveyor. A pipe conveyor is a conveyor where the sides of the belt are wrapped into an overlapping engagement and the belt forms a pipe enclosing the oil-bearing material until it reaches the discharge end, where the pipe opens into a conventional conveyor shape and the oil-bearing material is discharged thereafter. Preferably, a tramp magnet (20) is held close to the surface of the first conveyor (14) to remove iron debris, if any. The second conveyor (18) preferably discharges the oil-bearing material into a crusher (22) located above a slurry feed tank (30). Alternatively, it can also discharge the oil-bearing material directly into the slurry feed tank (30).

It should be noted that the screen (16) and the crusher (22) may be optional. For instance, the mining equipment (12) may efficiently grind the oil-bearing material on the mine face (M) so that subsequent crushing thereof is not required. However, in most cases, it is desirable to preprocess the raw mined material to

eliminate particles having a size above a maximum limit required for slurring and which may otherwise inflict operating difficulties or damage to the equipment.

The oil-bearing material supplied in the slurry feed tank (30) is mixed with a suitable solvent to form a slurry. The nature of the solvent depends on the kind of oil-bearing material being processed. In the case of tar sand, the solvent could be water and the water is preferably at least of equal weight with the oil-bearing material. The temperature of the supplied water is such that the slurry preferably has a temperature ranging from about 80° to 160° Fahrenheit (26°C to 72°C) in order to promote the separation of the bitumen, or a similar product, from the other constituents in the slurry.

The slurry in the slurry feed tank (30) is preferably agitated continuously using a mixer (32) or any other suitable device to achieve the same purpose.

From the slurry feed tank (30), the slurry is pumped or otherwise conveyed into the inlet of a first hydrocyclone (40). It should be noted that the term «hydrocyclone» also includes the case where two or more hydrocyclones are disposed in parallel. A hydrocyclone is essentially a device wherein the centrifugal force created by the swirling action of the fluid therein is used to separate a lighter portion of its content from a heavier portion thereof. The lighter portion is referred to as the «overflow portion» while the heavier portion is referred to as the «underflow portion». The overflow portion flows through an overflow outlet located at or near the top. The underflow portion flows through an underflow outlet at or near the bottom.

The slurry in the slurry feed tank (30) is preferably brought to the inlet of the first hydrocyclone (40) using a vertical submersible feed pump (34). The pump (34) has an inlet in the slurry feed tank (30) and an outlet in fluid communication with the inlet of the first hydrocyclone (40). The use of this particular kind of pump is preferred since it permits arrangements that eliminate the need for valves which are generally problematic in slurry service.

The overflow portion flowing through the overflow outlet of the first hydrocyclone (40) is oil enriched. This oil-enriched product is then either sent to another separation process in the apparatus(10), or sent directly as such into a product pipeline (36). The product pipeline (36) is preferably used to send the oil-enriched product to another processing plant where it will ultimately be upgraded into synthetic crude oil. Pumps are located at strategic locations to convey the oil-enriched product through the pipeline (36).

In the embodiment illustrated in FIG. 1, the process comprises the step of removing the solvent from the oil-enriched product, thus producing a further concentrated oil-enriched product before the product is sent out of the apparatus (10). One of the advantages of removing solvent from the oil-enriched product is that it can immediately be recycled back into an earlier stage of the process, thereby lowering the amount of fresh or recycled solvent that needs to be supplied to the apparatus (10) and the thermal energy to be furnished. The solvent is removed using a product separator, preferably a decanter (46), as illustrated in FIG. 1. Alternatively, the product separator could be another hydrocyclone in which the overflow portion is the further concentrated oil-enriched product, and the underflow portion contains the solvent to recycle.

The underflow portion of the first hydrocyclone (40) is a dense slurry containing mainly solvent and solids. However, it still contains some amount of kerogen, bitumen or other oil-carrying product which could be recovered by further processing the slurry. If this is not desired, the underflow portion is then directly vacuum filtered in order to remove solvent therefrom.

The vacuum filtering is preferably achieved by a vacuum belt filter system (48) or an equivalent thereof. As illustrated in FIG. 1, the vacuum filter (48) preferably comprises a porous endless conveyor belt (48a) under which is located a vacuum chamber (48b). The vacuum may be provided by a vacuum pump (48c). The slurry to filter is continuously laid on the conveyor belt (48a) at one end and the

solvent is removed therefrom as it is conveyed towards the discharge end. The solvent is brought into the vacuum chamber (48b) and is thereafter sent with the retrieved air into an air/liquid separator (48d) through corresponding lines. The solvent removed from the underflow portion is recycled back into an earlier stage  
5 of the process. The air/liquid separator (48d) preferably comprises an air outlet in fluid communication with the vacuum pump (48c). Preferably, the vacuum pump (48c) comprises an air outlet in fluid communication with a region in the vicinity of the belt (48a) of the vacuum filter (48). This has the advantage of conserving heat when the apparatus (10) operates in cold weather.

10 Substantially dewatered tailings (100) come out of the vacuum filter system (48). These tailings are said to be substantially «dewatered» since most of the solvent is removed therefrom and only enough solvent remains to provide geotechnical strength of the tailings (100) for stability of the deposition. The dewatered tailings (100) preferably fall on a tailings stacker (102), which is for instance a pipe  
15 conveyor arranged as a bridge and which conveys the tailings (100) out of the apparatus (10) for deposit in an adjacent area. The tailings (100) may be used to backfill the mine trenches.

The tailings stacker (102) is preferably in the form of a track-supported bridge-type pipe conveyor. Other variants are also possible.

20 Referring again to FIG. 1, the underflow portion coming out of the first hydrocyclone (40) preferably falls into a corresponding sump (42). A vertical submersible feed pump (44) is preferably located in the sump (42). This pump (44) has an inlet in the sump (42) and an outlet in fluid communication with the inlet of a second hydrocyclone (50). The second hydrocyclone (50) is used to  
25 separate the content of the first sump (42) into an overflow portion and an underflow portion.

In the second hydrocyclone (50), the overflow portion flows out through a corresponding overflow outlet and is preferably sent back to the slurry feed tank (30). The underflow portion of the second hydrocyclone (50) flows out through a corresponding underflow outlet and into a second sump (52).

5 The embodiment illustrated in FIG. 1 further comprises a third hydrocyclone (60). The content of the second sump (52) is then supplied to the inlet of the third hydrocyclone (60), preferably using a corresponding vertical submersible feed pump (54). The third hydrocyclone (60) separates the content of the second sump (52) into an overflow portion and an underflow portion. The overflow portion of the  
10 third hydrocyclone (60) flows out through an overflow outlet which is preferably made in fluid communication with the first sump (42). This allows a countercurrent washing circuit to be created. The underflow portion of the third hydrocyclone (60) flows out of an underflow outlet and goes into a third sump (62).

It is further possible to use a fourth or even more hydrocyclones in the process. If  
15 a fourth hydrocyclone is used, its overflow outlet would be in fluid communication with the inlet of the third hydrocyclone (60). In other words, the overflow portion coming out of a fourth hydrocyclone would be sent to the second sump (52). The general rule is that the overflow portion of an hydrocyclone, beginning with the third hydrocyclone (60), is preferably used to repulp the sump below the  
20 hydrocyclone which is two stages earlier. It is the underflow portion of the last of the hydrocyclones which is sent to the vacuum filter system (48).

If necessary, the content of the second sump (52) or the third sump (62) can be diluted with recycled solvent, for instance solvent coming from the decanter (44) or another source. This may be necessary since the concentration of solids  
25 increases from one hydrocyclone to another.

In the embodiment illustrated in FIG. 1, the third sump (62) is the final station before the vacuum filtering. A flocculant agent is advantageously added into the

third sump (62) before its content is sent to the vacuum filter system (48). The flocculent agent allows fine particles to agglomerate, making the vacuum filtering more effective. The flocculant agent is preferably stored in an agitated tank (64) and supplied into the third sump (62) using a corresponding pump (66). The  
5 content of the third sump (62) is preferably sent to the vacuum filter system (48) using a vertical submersible feed pump (68) having an inlet in the sump (62) and an outlet in fluid communication with the inlet of the vacuum filter system (48).

As can be appreciated, the process only requires the use of a relatively small amount of fresh solvent. Fresh solvent is added into the process to replace  
10 residual solvent in the oil-enriched product coming out of the product pipeline (36) and in the tailings (100). This fresh solvent preferably comes through a fresh solvent supply line (70) connected to a suitable source. Most of the fresh solvent is preferably sent into the slurry feed tank (30) following a network of lines. Some of this solvent can also be combined with recycled solvent. It can further be used  
15 to dilute the contents of some of the sumps. In the embodiment of FIG. 1, some of the fresh solvent could be sent into the second sump (52) if necessary.

The fresh solvent supply line (70) advantageously comprises a hose and a hose reel (72). The hose is preferably in the form of a flexible line to be connected to a service facility outlet. Similarly, the product pipeline (36) advantageously  
20 comprises a flexible hose and a hose reel (72) to be connected to an appropriate outlet. The product hose reel (74) and solvent supply hose reel are preferably mounted on transport crawler tracks and/or wheels, if necessary. Electrical powerlines (not shown) could be mounted the same way. All of these flexible connections provide relocatable umbilical connections for an efficient operation of  
25 the apparatus (10). Of course, other arrangements are possible, including the design of an apparatus having fully independent systems. In that case, the power could be supplied using generators while the fresh solvent and oil-enriched products are stored in corresponding tanks to be serviced from time to time.

A froth skimmer (76) is preferably provided in the slurry feed tank (30) in order to collect a froth which usually forms over the slurry. This primary froth is advantageously oil-enriched and can be directly combined with the stream coming out of the overflow outlet of the first hydrocyclone (40). In the embodiment of FIG. 1, the froth skimmer (76) comprises a pump (78) having an outlet in fluid communication with the inlet of the decanter (44). Similarly, froth skimmers can be employed on each of the hydrocyclone underflow sumps and the froth recovered combined with the overflow outlet of the first hydrocyclone (40).

The apparatus (10), when mobile or semi-mobile, is preferably moved using a ground-engaging undercarriage (80), and is preferably controlled by an operator installed at the front section. This ground-engaging undercarriage (80) supports the apparatus (10) and repositions as required. The undercarriage (80) preferably comprises motorized crawler tracks or wheels. In the embodiment of FIGS. 1 to 4, the undercarriage (80) comprises motorized crawler tracks, which are preferred since they are generally more suitable for moving very large and heavy equipment over unpaved surfaces.

Heat is preferably provided to the system using the fresh solvent. Hence, the fresh solvent is supplied in a heated state so as to provide heat for the slurry in the slurry feed tank (30) or any other suitable location. Alternatively, or in addition to the heated fresh solvent supply, a solvent heater (not shown) can be used in order to increase the temperature of the solvent or the slurry in the process. A further alternative is that the solvent in the oil-enriched product be recovered in a remote processing plant, heated at that location with any available heating media, such as waste heat, and then returned to the apparatus (10) via flexible hoses together with, or separate from, fresh solvent. However, this is essentially a matter for capital and operating cost optimization with the fixed plant infrastructure on a site specific basis.

## EXAMPLE

The following Table 1 is an example of a material balance using a process as illustrated in FIG. 1 for recovering bitumen from tar sand. The various stream numbers are identified with the reference numerals in hexagons.

5 TABLE 1: MATERIAL BALANCE

Stream No.		1	2	3	4	5	6	7
Bitumen	t/h	240	1	124	37	49	34	15
Water	t/h	100	885	2228	669	2194	1536	658
Solids	t/h	1660	91	1919	1688	1903	228	1675
<b>Total</b>	t/h	<b>2000</b>	<b>978</b>	<b>4271</b>	<b>2394</b>	<b>4146</b>	<b>1798</b>	<b>2348</b>
Bitumen	wt%	12.0	.01	2.9	1.9	1.2	1.9	0.6
Water	wt%	5.0	90.6	51.3	27.9	52.9	85.4	28.0
Solids	wt%	83.0	9.3	44.9	70.5	45.9	12.7	71.3
Heat capacity	Btu/lb/F	0.271	0.924	0.629	0.440	0.633	0.886	0.440
Specific gravity		2.24	1.06	1.41	1.83	1.41	1.09	1.84
Total Volume	USGPM	3568	3694	12124	5231	11716	6613	5107
Temp	°F	32	94	78	78	85	85	85

Stream No.	8	9	10	11	12	13	14
Bitumen	16	11	5	5	0	5	87
Water	2179	1525	654	656	2	273	1560
Solids	1792	215	1577	1577	0	1577	230
<b>Total</b>	<b>3987</b>	<b>1752</b>	<b>2235</b>	<b>2237</b>	<b>2</b>	<b>1854</b>	<b>1877</b>
Bitumen	0.4	0.7	0.2	0.2	0.0	0.3	4.6
Water	54.7	87.1	29.2	29.3	100.0	14.7	83.1
Solids	44.9	12.3	70.5	70.5	0.0	85.0	12.3
Heat capacity	0.646	0.897	0.449	0.449	0.997	0.336	0.871
Specific gravity	1.40	1.08	1.81	1.81	1.00	2.18	1.09
Total Volume	11399	6475	4924	4932	8	3394	6900
Temp	90	90	90	90	80	90	78

Stream No.	15	16	17	18	19	20	21
Bitumen	235	0	0	151	0	0	-
Water	109	383	0	293	280	383	-
Solids	83	0	0	61	0	0	-
<b>Total</b>	<b>427</b>	<b>383</b>	<b>0</b>	<b>505</b>	<b>280</b>	<b>383</b>	<b>-</b>
							-
Bitumen	55.0	0.0	0.0	30.0	0.0	0.0	-
Water	25.5	100.0	100.0	58.0	100.0	100.0	-
Solids	19.5	0.0	0.0	12.0	0.0	0.0	-
Heat capacity	0.480	0.997	0.245	.0704	1.003	0.997	-
Specific gravity	1.19	1.00	0.88	1.11	0.96	1.00	-
Total Volume	1429	1538	407	1822	1157	1538	-
Temp	78	90	140	78	195	90	-

Stream No.	22	23	24	26	27	28	30	31
Bitumen	2	238	3	0.00	0.00	0	3	3
Water	1138	1853	1744	0.00	0.00	1	1744	2023
Solids	117	291	207	0.00	0.00	0	207	207
<b>Total</b>	<b>1256</b>	<b>2382</b>	<b>1954</b>	<b>0</b>	<b>0</b>	<b>10</b>	<b>1954</b>	<b>2234</b>
Bitumen	0.4	10.0	.02	0.0		0.0	0.2	.01
Water	84.4	77.8	89.2	100.0		100.0	89.2	90.6
Solids	15.2	12.2	10.5	0.0		0.0	10.5	10.5
Heat capacity	0.924	0.835	0.914	0.245	1		0.914	0.924
Specific gravity	1.06	1.09	1.07	0.96	0.96	0.96	1.07	1.06
Total Volume	4746	8724	7294	373			7294	8440
Temp	94	78	78	90	165	160	78	94

- 5 As can be appreciated, the process allows a very efficient recovery of bitumen, or any other oil-enriched product from tar sand.

As can also be appreciated, the use of the apparatus that is capable of processing oil-bearing materials on-site and depositing the resulting tailings in the mined out area in the immediate vicinity, dramatically reduces the material handling undertaking. The advantages of this apparatus and the corresponding process  
5 over conventional recovery technologies are major. These advantages include:

- much higher energy efficiency and consequent lower carbon dioxide generation;
- much smaller disturbed land footprint;
- no tailings ponds with their attendant need for eventual remediation;
- 10 • possible land reclamation and reforestation on a short term;
- no ore sterilization by tailings ponds because there are none;
- reduced air pollution from equipment because much less equipment is required;
- reduced draw of fresh water resources due to the recycling of process water  
15 when used as a solvent;
- reduced consumption of granular resources;
- increased thermal efficiency due to the recycle of process solvent;
- increased value of the tar sand reserve because of overall cost efficiency; and
- much reduced possibility of environmental impact that could trigger significant  
20 concerns to the public.

Although a preferred and other possible embodiments of the invention have been described in detail herein and illustrated in the accompanying figures, it is to be understood that the invention is not limited to these embodiments since various  
25 changes and modifications may be effected therein without departing from the scope or spirit of the present invention.

**WHAT IS CLAIMED IS :**

1. A process for recovering an oil-enriched product from an oil-bearing material, the process comprising the steps of:
  - (a) mixing the oil-bearing material with a solvent to form a slurry in a slurry feed tank,;
  - (b) pumping the slurry into an hydrocyclone to separate it into an overflow portion and an underflow portion, the overflow portion containing the oil-enriched product;
  - (c) vacuum filtering the underflow portion to remove solvent therefrom and produce substantially dewatered tailings;
  - (d) recycling the solvent removed from the underflow portion back into an earlier stage of the process; and
  - (e) adding fresh solvent into the process to replace residual solvent in the oil-enriched product and in the tailings.
2. The process according to claim 1, wherein the solvent is at least equal in weight with the oil-bearing material.
3. The process according to claim 1 or 2, further comprising conveying the tailings out for deposition in an adjacent area.
4. The process according to any one of claims 1 to 3, wherein the fresh solvent is fed into the slurry feed tank.

5. The process according to any one of claims 1 to 4, further comprising removing some of the solvent from the overflow portion to obtain a further concentrated oil-enriched product, and recycling the solvent removed from the overflow portion back into the slurry feed tank.
6. The process according to claim 5, wherein the step of removing some of the solvent from the overflow portion comprises decanting the same.
7. The process according to any one of claims 1 to 6, wherein the solvent comprises water and the slurry in the slurry feed tank has a temperature substantially ranging from 80 to 160 degrees Fahrenheit.
8. The process according to claim 7, wherein at least a portion of the heat is supplied in the process using the fresh solvent.
9. The process according to any one of claims 1 to 8, further comprising the step of adding flocculant to the underflow portion before vacuum filtering the same.
10. The process according to any one of claims 1 to 9, further comprising the step of skimming a froth formed on the slurry and adding the froth to the overflow portion before the solvent is removed therefrom.
11. The process according to any one of claims 1 to 10, further comprising screening oversize ore lumps from the oil-bearing material and feeding them into a crusher to reduce their size to under a maximum limit required for slurring, the crushed materials being thereafter brought into the slurry feed tank.
12. The process according to claim 11, wherein at least some of the oversize ore lumps are diverted to the tailings.

13. The process according to claim 11 or 12, wherein the oversize ore lumps are dumped onto the ground when not suitable for processing.
14. The process according to any one of claims 11 to 13, wherein the oil-bearing material is diverted to the tailings when not suitable for processing.
15. The process according to any one of claims 1 to 14, wherein the oil-bearing material comprises tar sand.
16. A process for recovering an oil-enriched product from an oil-bearing material, the process comprising:
  - (a) mixing the oil-bearing material with a solvent in a slurry feed tank, the solvent being and the oil-bearing material being agitated to form a primary slurry;
  - (b) pumping the primary slurry into a first hydrocyclone to separate it into a first overflow portion and a first underflow portion;
  - (c) pumping the first underflow portion into a second hydrocyclone to separate it into a second overflow portion and a second underflow portion;
  - (d) pumping the second overflow portion into the slurry feed tank;
  - (e) vacuum filtering the underflow portion of the last of the hydrocyclones to remove solvent therefrom and produce substantially dewatered tailings;
  - (f) conveying the tailings out of the apparatus for deposition in an adjacent area;

- (g) recycling the solvent removed from the underflow portion of the last of the hydrocyclones into an earlier stage of the process; and
  - (h) adding fresh solvent into the process to replace residual solvent in the oil-enriched product and in the tailings.
17. The process according to claim 16, wherein the solvent is at least equal in weight with the oil-bearing material.
18. The process according to claim 16 or 17, further comprising the step of removing some of the solvent from the first overflow portion to obtain a further concentrated oil-enriched product, and recycling the solvent removed from the first overflow portion into an earlier stage of the process.
19. The process according to claim 18, wherein the step of removing some of the solvent from the first overflow portion comprises decanting the same.
20. The process according to any one of claims 16 to 19, wherein at least a portion of the solvent in the oil-enriched product is separated in a remote processing plant, heated therein and then recycled back into the apparatus.
21. The process according to any one of claims 16 to 20, wherein the solvent comprises water and the slurry in the slurry feed tank has a temperature substantially ranging from 80 to 160 degrees Fahrenheit.
22. The process according to claim 21, wherein at least a portion of the heat is supplied in the process using the fresh solvent.

23. The process according to any one of claims 16 to 22, further comprising the step of adding flocculant to the underflow portion of the last hydrocyclone before vacuum filtering the same.
24. The process according to any one of claims 16 to 23, further comprising the step of skimming a froth formed on the primary slurry and adding the froth to the first overflow portion.
25. The process according to any one of claims 16 to 24, further comprising the step of pumping the second underflow portion into a third hydrocyclone to separate it into a third overflow portion and a third underflow portion, the third overflow portion being added to the first underflow portion.
26. The process according to claim 25, further comprising the step of pumping the third underflow portion into a fourth hydrocyclone to separate it into a fourth overflow portion and a fourth underflow portion, the fourth overflow portion being added to the second underflow portion.
27. The process according to any one of claims 16 to 26, further comprising the step of pre-processing the oil-bearing material before mixing it with the solvent to eliminate particles having a size above a maximum limit required for slurring.
28. The process according to claim 27, wherein the step of pre-processing the oil-bearing material comprises screening it to remove oversize ore lumps.
29. The process according to claim 28, wherein at least some of the oversize ore lumps are fed into a crusher to reduce lump size to under the maximum limit for required for slurring.

30. The process according to claim 28, wherein at least some of the oversize ore lumps are by-passed and added to the tailings.
31. The process according to claim 28, wherein the oversize ore lumps are dumped onto the ground when not suitable for processing.
32. The process according to any one of claims 27 to 31, wherein the step of pre-processing the oil-bearing material comprises feeding at least some of it into a crusher before mixing it with the solvent.
33. The process according to any one of claims 16 to 31, wherein the oil-bearing material is diverted to the tailings when not suitable for processing.
34. The process according to any one of claims 16 to 32, wherein the oil-bearing material comprises tar sand.
35. An apparatus for recovering an oil-enriched product from an oil-bearing material, the apparatus comprising:
  - (a) a slurry feed tank in which the oil-bearing material is mixed with a solvent to form a slurry;
  - (b) a hydrocyclone having an inlet in fluid communication with the slurry feed tank, the hydrocyclone comprising an overflow outlet and an underflow outlet;
  - (c) a vacuum filter having an inlet in fluid communication with the underflow outlet of the hydrocyclone, the vacuum filter further having a first outlet that outputs substantially dewatered tailings, and a second outlet that outputs substantially solvent and air; and

- (d) an air/liquid separator having an inlet in fluid communication with the second outlet of the vacuum filter, the separator further having a first outlet that outputs substantially the solvent to be recycled, and a second outlet that outputs substantially air.
36. The apparatus according to claim 35, wherein the solvent comprises water which is supplied in a heated state so as to provide heat to the slurry in the slurry feed tank.
37. The apparatus according to claim 36, wherein the slurry in the slurry feed tank has a temperature substantially ranging from 80° to 160° Fahrenheit.
38. An apparatus according to any one of claims 35 to 37, further comprising a concentrator having an inlet in fluid communication with the overflow outlet of the hydrocyclone, the concentrator further having a first outlet that outputs a further concentrated oil-enriched product, and a second outlet that outputs substantially solvent to be recycled.
39. The apparatus according to any one of claims 35 to 38, further comprising a flocculant tank having an outlet in fluid communication with the inlet of the vacuum filter.
40. The apparatus according to claim 39, further comprising:
- a sump in fluid communication with the underflow outlet of the hydrocyclone and the outlet of the flocculant tank; and
  - a vertical submersible feed pump having an inlet in the sump and an outlet in fluid communication with the inlet of the vacuum filter.

41. The apparatus according to any one of claims 35 to 40, further comprising a froth skimmer having an outlet in fluid communication with the inlet of the concentrator.
42. The apparatus according to claim 41, wherein the froth skimmer comprises a feed pump.
43. The apparatus according to claim 41 or 42, wherein the froth skimmer comprises an overflow weir, collection launders and a feed pump.
44. The apparatus according to any one of claims 35 to 43, further comprising a bypass path by which the oil-bearing material is diverted to a tailings conveyor when not suitable for processing.
45. The apparatus according to any one of claims 35 to 43, further comprising a vertical submersible feed pump having an inlet in the slurry feed tank, and an outlet in fluid communication with the inlet of the hydrocyclone.
46. The apparatus according to any one of claims 35 to 45, wherein the oil-bearing material comprises tar sand.
47. An apparatus for recovering an oil-enriched product from an oil-bearing material, the apparatus comprising a supporting platform on which are mounted:
  - (a) an oil-bearing material inlet;
  - (b) a slurry feed tank in which the oil-bearing material is mixed with a solvent to form a slurry;
  - (c) a first conveyor to carry the oil-bearing material from the oil-bearing material inlet;

- (d) a second conveyor which transports the oil-bearing material from a discharge end of the first conveyor into the slurry feed tank;
- (e) a mixer located in the slurry feed tank;
- (f) a first hydrocyclone having an inlet in fluid communication with the slurry feed tank, the first hydrocyclone comprising an overflow outlet and an underflow outlet;
- (g) a second hydrocyclone having an inlet in fluid communication with the underflow outlet of the first hydrocyclone, the second hydrocyclone comprising an overflow outlet and an underflow outlet, the overflow of the second hydrocyclone being in fluid communication with the slurry feed tank;
- (h) a vacuum filter having an inlet in fluid communication with the underflow outlet of the last of the hydrocyclones, the vacuum filter further having a first outlet that outputs substantially dewatered tailings, and a second outlet that outputs substantially the solvent and air;
- (i) an air/liquid separator having an inlet in fluid communication with the second outlet of the vacuum filter, the separator further having a first outlet that outputs substantially the solvent to be recycled, and a second outlet that outputs substantially air;
- (j) a tailings conveyor to carry the tailings from the first outlet of the vacuum filter out of the apparatus for deposition in an adjacent area;
- (k) a fresh solvent supply being at least partially in fluid communication with the slurry feed tank; and

- (l) a ground-engaging undercarriage to support the apparatus and reposition it.
48. The apparatus according to claim 47, wherein the solvent comprises water supplied in a heated state so as to provide heat for the slurry in the slurry feed tank.
49. The apparatus according to claim 48, wherein the slurry in the slurry feed tank has a temperature substantially ranging from 80° to 160° Fahrenheit.
50. The apparatus according to any one of claims 47 to 49, further comprising a concentrator having an inlet in fluid communication with the overflow outlet of the first hydrocyclone, the concentrator further having a first outlet that outputs a further concentrated oil-enriched product, and a second outlet that outputs substantially the solvent to be recycled at an earlier stage.
51. The apparatus according to claim 50, further comprising a froth skimmer in fluid communication with the inlet of the concentrator.
52. The apparatus according to claim 51, wherein the froth skimmer comprises a feed pump.
53. The apparatus according to claim 51 or 52, wherein the froth skimmer comprises an overflow weir.
54. The apparatus according to any one of claims 47 to 53, further comprising a flocculent tank having an outlet in fluid communication with the inlet of the vacuum filter.

55. The apparatus according to any one of claims 47 to 54, further comprising a by-pass path by which the oil-bearing material is diverted to the tailings when not suitable for processing.
56. The apparatus according to any one of claims 47 to 55, further comprising a screen to remove oversize ore lumps from the oil-bearing material.
57. The apparatus according to claim 56, further comprising a by-pass path by which oversize ore lumps are deviated to the tailings conveyor when not suitable for processing.
58. The apparatus according to claim 56, wherein the by-pass path comprises an exterior outlet so that the oversize ore lumps are dumped onto the ground when not suitable for processing.
59. The apparatus according to any one of claims 47 to 58, further comprising a vertical submersible feed pump having an inlet in the slurry feed tank, and an outlet in fluid communication with the inlet of the first hydrocyclone.
60. The apparatus according to any one of claims 47 to 59, further comprising a third hydrocyclone having an inlet in fluid communication with the underflow outlet of the second hydrocyclone, the third hydrocyclone comprising an overflow outlet and an underflow outlet, the overflow outlet of the third hydrocyclone being in fluid communication with the inlet of the second hydrocyclone.
61. The apparatus according to claim 60, further comprising a fourth hydrocyclone having an inlet in fluid communication with the underflow outlet of the third hydrocyclone, the fourth hydrocyclone comprising an overflow outlet and an underflow outlet, the overflow outlet of the fourth hydrocyclone being in fluid communication with the inlet of the third hydrocyclone.

62. The apparatus according to any one of claims 47 to 61, wherein each hydrocyclone has a corresponding sump and a corresponding vertical submersible feed pump, the three of which form a subset, each sump being in fluid communication with the underflow outlet of the hydrocyclone of its subset, and each feed pump having an inlet in the sump of its subset and an outlet in fluid communication with the inlet of where the underflow outlet of the hydrocyclone of its subset is connected.
63. The apparatus according to any one of claims 47 to 62, wherein the tailings conveyor includes a bridge-type pipe conveyor.
64. The apparatus according to any one of claims 47 to 63, wherein the oil-bearing material comprises tar sand.

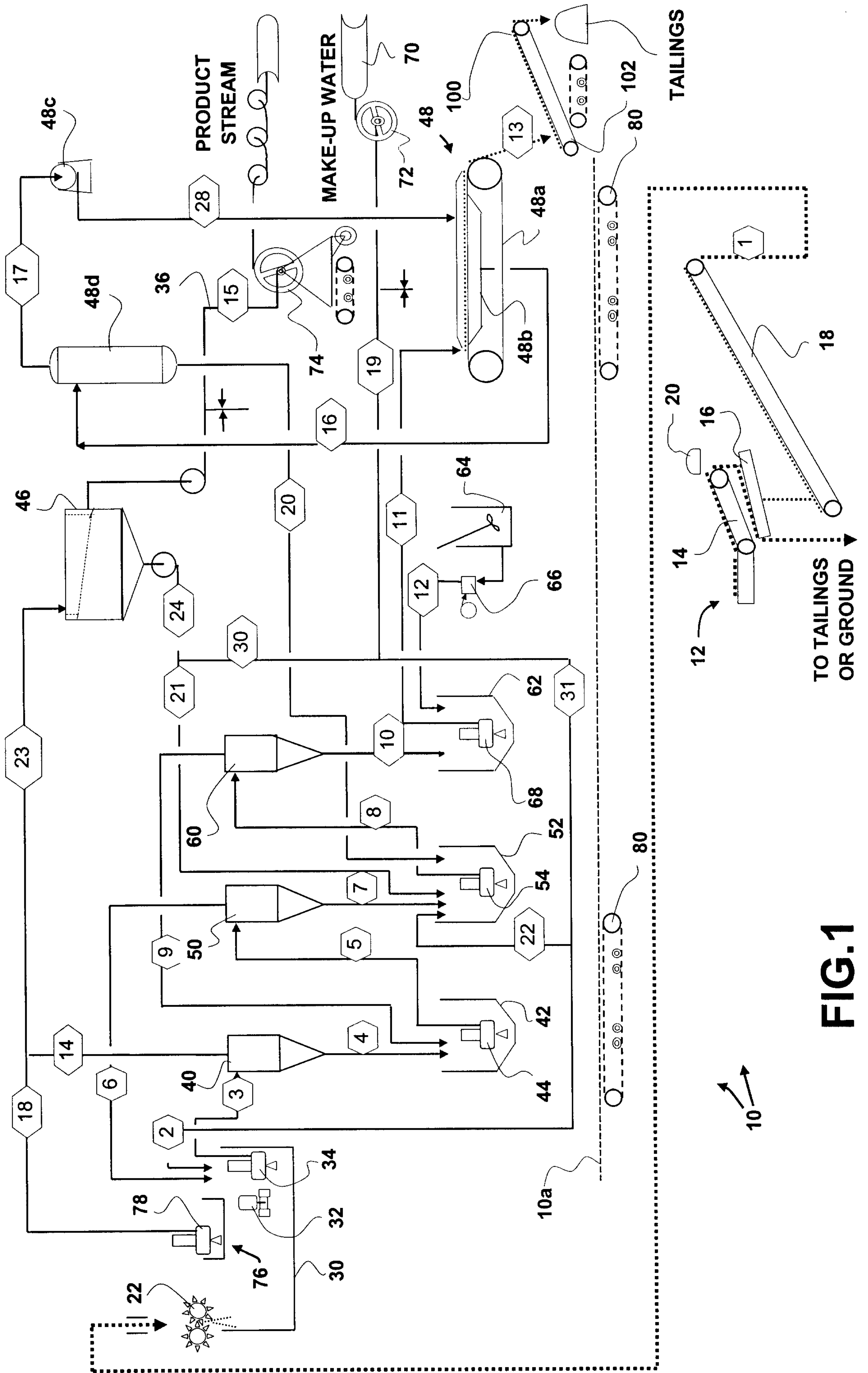

FIG. 1

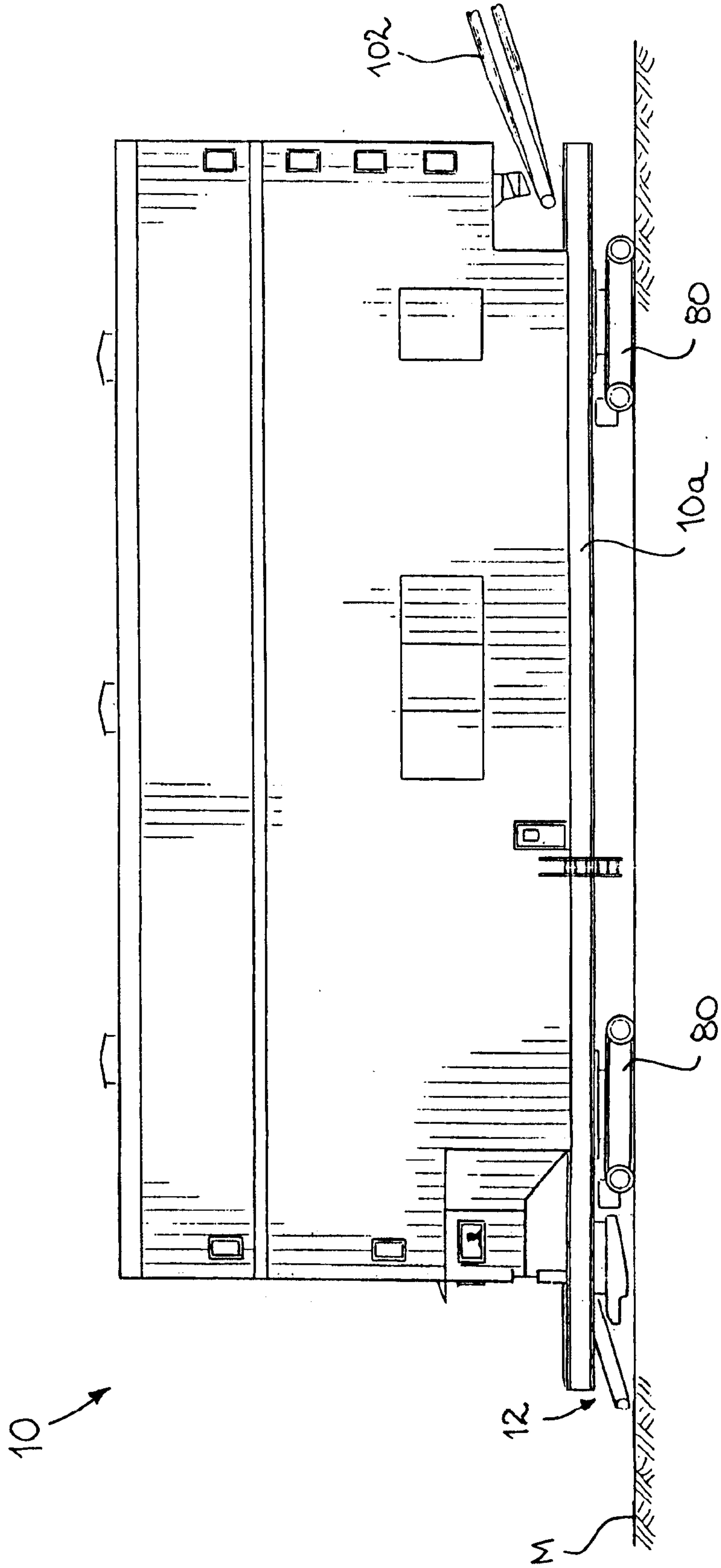

FIG.2

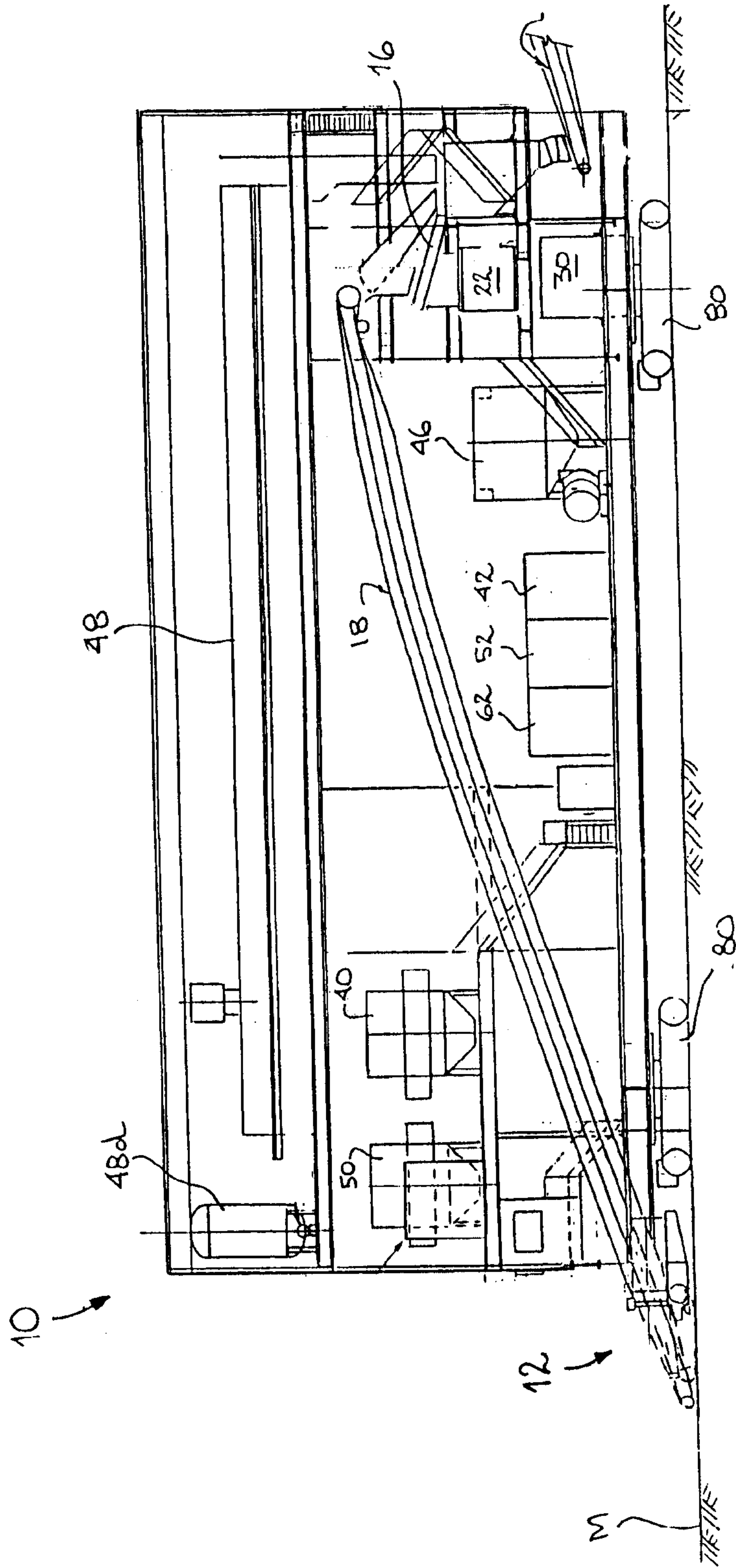
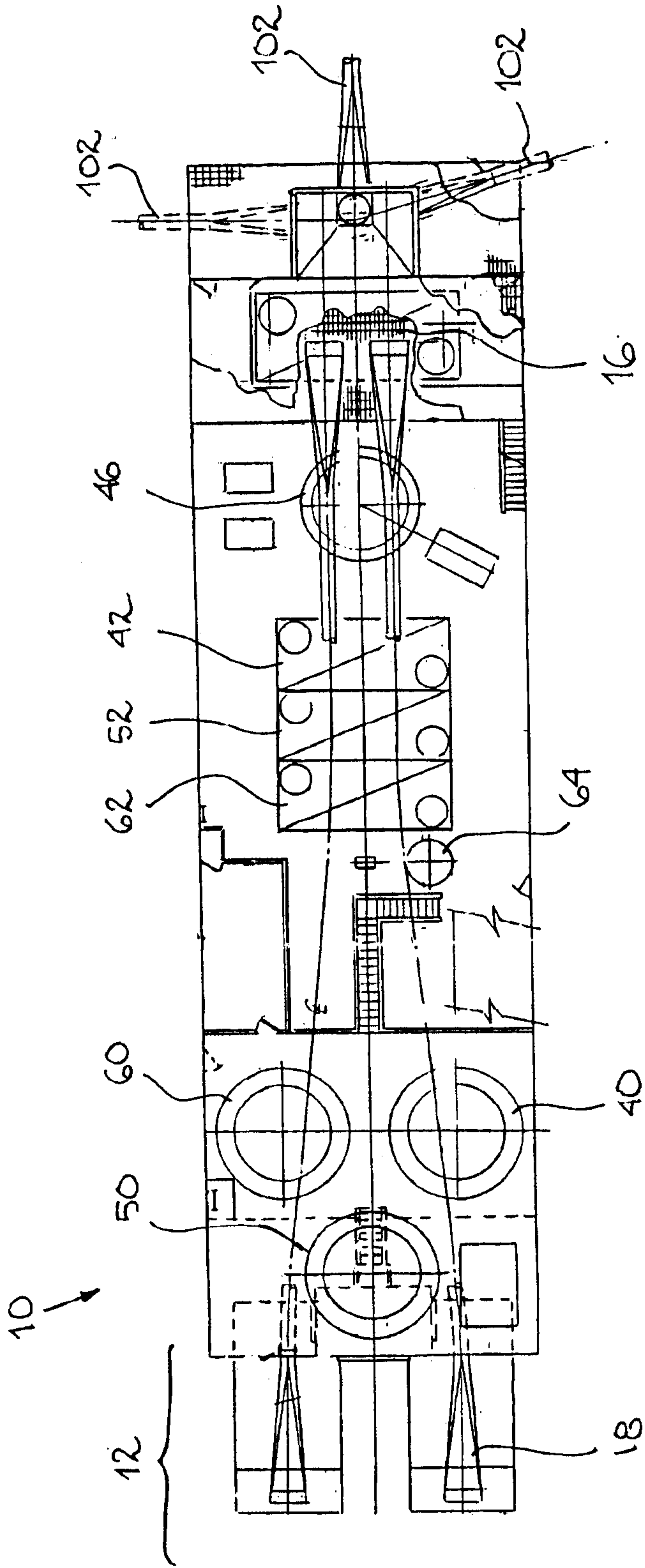

FIG.3



**FIG. 4**

