

(No Model.)

A. COCHRANE.
ELECTRICAL HEATER.

No. 516,152.

Patented Mar. 6, 1894.

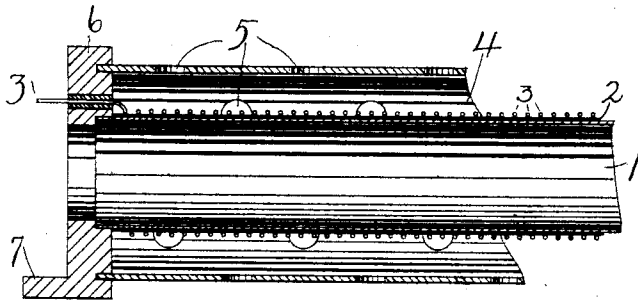

Fig. 2.

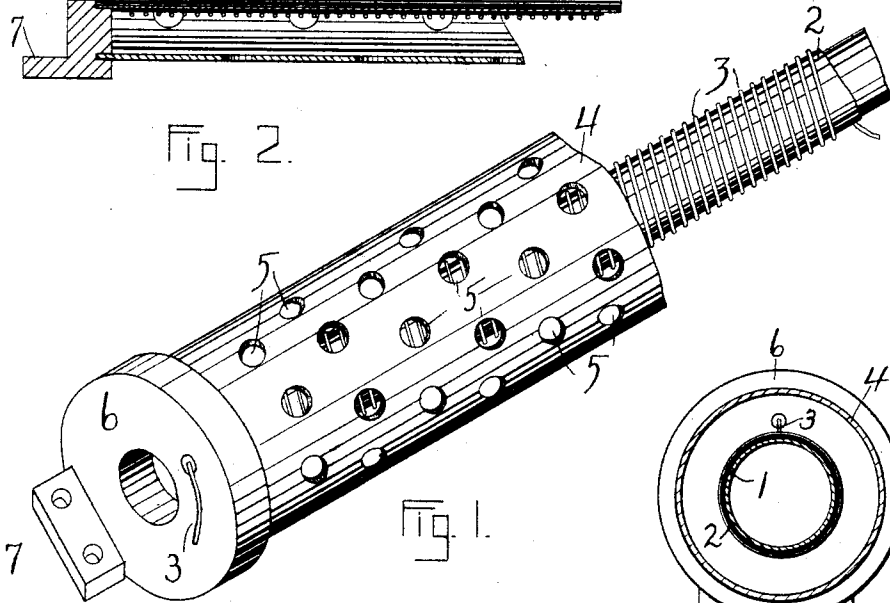

Fig. 1.

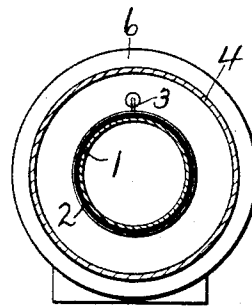

Fig. 3.

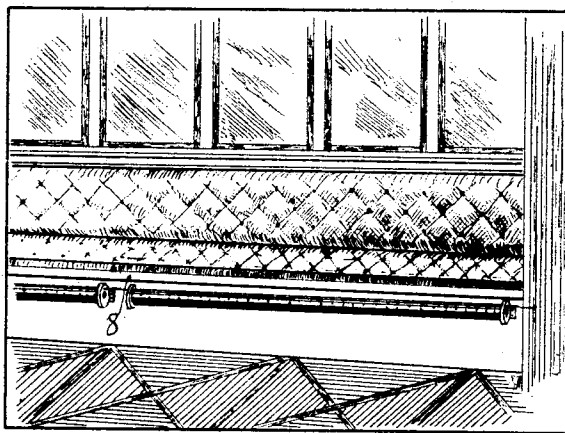

Fig. 4.

Witnesses.

Chas. A. Kellogg.
Chas. F. Hoover.

Inventor.

Adam Cochrane
by his attorney
Abby L. Hayes.

UNITED STATES PATENT OFFICE.

ADAM COCHRANE, OF LOWELL, MASSACHUSETTS.

ELECTRICAL HEATER.

SPECIFICATION forming part of Letters Patent No. 516,152, dated March 6, 1894.

Application filed January 6, 1893. Serial No. 457,518. (No model.)

To all whom it may concern:

Be it known that I, ADAM COCHRANE, a citizen of the United States, residing at Lowell, in the county of Middlesex and State of Massachusetts, have invented a new and useful Improvement in Electrical Heaters, of which the following, taken in connection with the accompanying drawings, is a specification.

The object of this invention is the economical production of heat by means of electricity, and the advantageous utilization of this heat for heating a street railroad car.

To these ends the invention consists, in the combination, substantially as and for the purpose hereinafter more fully set forth, of a tube open at both ends covered externally with asbestos or some similar material which is a non-conductor of heat and electricity; a helix of wire of German silver or other metal of high resistance; a foraminous or perforated tube or cylinder of any suitable material inclosing this helix and tube, but of such diameter that there is a space between the outer and inner tubes; and ring shaped heads in which the ends of the tubes are secured, and by means of which the device can be secured in position.

In the accompanying drawings, Figure 1 is an isometrical view of the heater with a part of the outer tube or cylinder shown as broken away, in order to show the helix and inner tube. Fig. 2 is a longitudinal sectional view of the heater. Fig. 3 is a transverse sectional view of the same. Fig. 4 is a view of part of the interior of a street car and shows the heater in position.

In the several figures the same numerals refer to the same parts.

Referring to the drawings, 1 is a tube of metal or of any other suitable material, preferably about one inch in diameter and four feet long, although it may be larger or smaller as may be desired.

2 is a coating of asbestos or other suitable heat resisting material which is a non-conductor of heat and of electricity.

3 is a helix of German silver wire or wire of any other suitable metal of high resistance, which helix is placed upon the coating and is so connected at each end that a current of electricity can be made to flow through the

helix. The gage of the wire may be such as is found most advantageous for the purpose, but experiment has shown that No. 28 wire gives very good results.

4 is another tube made of tin, thin wood, papier maché or of any other suitable substance, arranged concentrically with the tube 1, and preferably about two inches in diameter, so that there is a space between the two tubes. In this outer tube are a large number of openings, 5, by means of which air is admitted between the two tubes, and from which openings the air after having been heated by contact with the heated helix, passes into the car. A constant circulation of air is thus maintained, and a large volume of air is exposed to the action of the heat.

The ends of the tubes 1 and 4 are properly secured in a head, 6, and in this head is a central opening, a little less in diameter than the diameter of the inner tube, which opening is made in order to permit air to pass freely through the inner tube. The asbestos covering is not sufficiently thick to prevent the heated wire from communicating considerable heat to the air passing through the tube, and thus a volume of heated air is supplied to the car in addition to that which is heated in the space between the tubes 1 and 4, and passes from the openings 5.

It will readily be seen that nearly all the heat generated in the helix by the passage of the current of electricity through the same is utilized, and that by thus passing independent currents of air through the two tubes a greater volume of the air will be more uniformly, moderately, and quickly heated than heretofore in this class of devices.

A bracket, 7, may be fixed to each of the heads, 6, for the purpose of properly securing the heater to the rising board of the seat.

The electrical heaters which have heretofore been used in street railway cars have generally been placed under the car or the car seat, whereby much heat is wasted, but the construction of my heater is such that, without occupying any of the space required for the proper accommodation of passengers, it can be placed inside the car, and thus prevent loss of heat.

I prefer to place my heater on the rising

board of the car seat, and under the flange formed by the projecting cap-board, as shown in Fig. 4.

The heaters are arranged end to end, and are preferably connected in series. Any number of these heaters may be used, and they may be placed one above the other if desired. It has been found that when they are arranged as shown in Fig. 4, sufficient heat will be obtained to comfortably heat a car when the resistance of the heaters is such that, with the ordinary pressure of five hundred volts used in electrical street car service, the volume of the current passing through the heaters will be four ampères, which means an expenditure of less than three horse-power.

I have shown this heater as used for heating a street railway car, but I do not limit its use to this purpose, and it can be used for heating rooms or for other purposes.

Having thus described my invention, what I claim, and desire to secure by Letters Patent of the United States, is—

An electric heater comprising horizontal tubes disposed one within the other, ring-shaped heads at the opposite ends of said tubes, and a helix of high resistance wire disposed adjacent to the inner tube and insulated therefrom, the outer tube being perforated along its periphery and closed at its ends, and the inner tube being open at its ends and closed along its periphery, said heater having independent heating chambers through which air may pass in independent currents at right angles to each other, one of said chambers being within the inner tube and the other between the inner and outer tubes, substantially as set forth.

In testimony whereof I have signed my name to this specification, in the presence of two subscribing witnesses, on this 30th day of December, A. D. 1892.

ADAM COCHRANE.

Witnesses:

THOMAS LEES,
HUGH COCHRANE.