



(51) International Patent Classification:

F16B 21/18 (2006.01) F16B 43/00 (2006.01)

(21) International Application Number:

PCT/GB2023/051603

(22) International Filing Date:

20 June 2023 (20.06.2023)

(25) Filing Language:

English

(26) Publication Language:

English

(30) Priority Data:

2210635.5 20 July 2022 (20.07.2022) GB

(71) Applicant: **CROSS MANUFACTURING COMPANY (1938) LIMITED** [GB/GB]; Midford Road, Combe Down, Bath BA2 5RR (GB).

(72) Inventor: **CROSS, Edward**; c/o Cross Manufacturing Company (1938) Limited, Midford Road, Combe Down, Bath BA2 5RR (GB).

(74) Agent: **WYNNE-JONES IP LIMITED**; Southgate House, Southgate Street, Gloucester GL1 1UB (GB).

(81) Designated States (unless otherwise indicated, for every kind of national protection available): AE, AG, AL, AM, AO, AT, AU, AZ, BA, BB, BG, BH, BN, BR, BW, BY, BZ, CA, CH, CL, CN, CO, CR, CU, CV, CZ, DE, DJ, DK, DM, DO, DZ, EC, EE, EG, ES, FI, GB, GD, GE, GH, GM, GT, HN, HR, HU, ID, IL, IN, IQ, IR, IS, IT, JM, JO, JP, KE, KG, KH, KN, KP, KR, KW, KZ, LA, LC, LK, LR, LS, LU, LY,

MA, MD, MG, MK, MN, MU, MW, MX, MY, MZ, NA, NG, NI, NO, NZ, OM, PA, PE, PG, PH, PL, PT, QA, RO, RS, RU, RW, SA, SC, SD, SE, SG, SK, SL, ST, SV, SY, TH, TJ, TM, TN, TR, TT, TZ, UA, UG, US, UZ, VC, VN, WS, ZA, ZM, ZW.

(84) Designated States (unless otherwise indicated, for every kind of regional protection available): ARIPO (BW, CV, GH, GM, KE, LR, LS, MW, MZ, NA, RW, SC, SD, SL, ST, SZ, TZ, UG, ZM, ZW), Eurasian (AM, AZ, BY, KG, KZ, RU, TJ, TM), European (AL, AT, BE, BG, CH, CY, CZ, DE, DK, EE, ES, FI, FR, GB, GR, HR, HU, IE, IS, IT, LT, LU, LV, MC, ME, MK, MT, NL, NO, PL, PT, RO, RS, SE, SI, SK, SM, TR), OAPI (BF, BJ, CF, CG, CI, CM, GA, GN, GQ, GW, KM, ML, MR, NE, SN, TD, TG).

Published:

- with international search report (Art. 21(3))
- in black and white; the international application as filed contained color or greyscale and is available for download from PATENTSCOPE

(54) Title: RING FASTENER

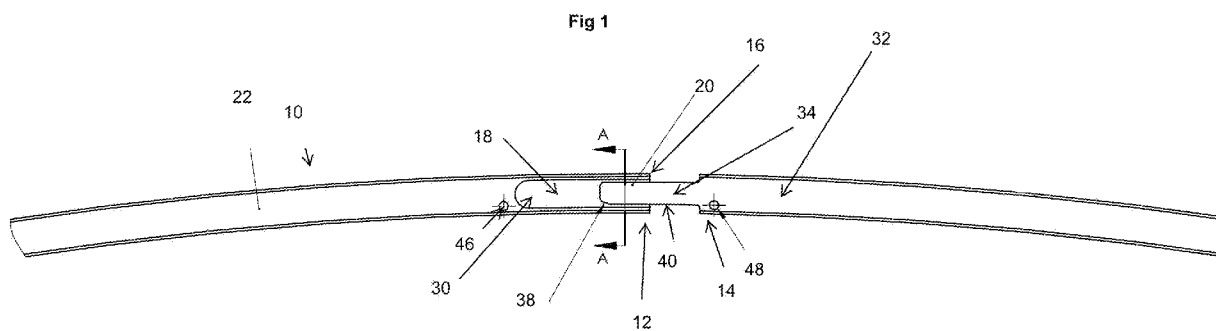

(57) Abstract: A ring fastener comprising a discontinuous band having first and second axial faces on opposite sides, a first end with a first end face and a groove extending from the first end face and opening to the first axial face; a second end with a second end face and a tongue projecting from the second end face; wherein the groove is u-shaped and the second axial face defines the base of the groove, and the tongue is dimensioned to fit in the groove; such that, when the tongue is received in the groove, the first end is located relative to the second end and a continuous ring is formed. A method of assembling the ring fastener into a circumferential groove in a component comprises the steps of feeding the ring fastener into the groove so that the ends are adjacent to each other; distorting the second end axially out of the plane of the groove; bringing the ends towards each other until the tongue overlies the groove; and inserting the tongue into the groove so that the ends are within groove.



RING FASTENER

FIELD OF INVENTION

[0001] This invention relates to a ring fastener, such as a retaining ring, and methods of assembling the ring fastener into a groove of a component.

BACKGROUND TO THE INVENTION

[0002] Retaining rings can have many different applications, but are often used to secure components together, such as to secure two rotating parts together. For example, a retaining ring can be fitted into a groove on an internal surface of a bore to act as a shoulder to mount or secure a component in the bore.

[0003] One example of a retaining ring is a spiral retaining ring, which comprises a single turn band with a gap in the circumference of the ring. When installed, the ends of the ring are brought together and can be in contact. However, during use, any thermal expansion of the ring can cause the ends of the ring to move apart, thus opening up the gap. This type of retaining ring therefore does not provide reliable full circumference support for the components during use.

[0004] Some retaining rings overcome this problem by providing a two or more turn retaining ring. However, the material used to produce such a ring is much thinner than a single turn ring, and as such each ring does not provide sufficient torsional stiffness. This can result in the ring twisting during use, which can reduce the stability of the ring and its ability to effectively secure components together.

[0005] WO2020/234572 describes a ring fastener comprising a discontinuous band having a first end and a second end. The first end comprises a pair of spaced-apart elongate finger members (having a first finger member and a second finger member), and the second end comprises an elongate tongue member. The finger members and the tongue member are interlockable, such that when interlocked, the band comprises a continuous circumference. The ring fastener further comprises a closed configuration wherein the finger members and the tongue member are substantially aligned with a circumferential surface of the band; and an open configuration wherein the first finger member is radially and/or axially deflected from its substantially aligned position, so that it is angled with respect to the circumferential surface of the band.

[0006] The present invention therefore aims to provide reliable full circumference support during use, whilst also maintaining a stable and effective connection between two components with a relatively simple and robust construction.

SUMMARY OF THE INVENTION

[0007] A first aspect of the invention comprises a ring fastener comprising:
a discontinuous band having first and second axial faces on opposite sides,
a first end with a first end face and a groove extending from the first end face and opening to the first axial face;
a second end with a second end face and a tongue projecting from the second end face

wherein the tongue is dimensioned to fit in the groove;

such that, when the tongue is received in the groove, the first end is located relative to the second end and a continuous ring is formed.

[0008] The tongue and groove arrangement is relatively robust and can be assembled and disassembled by simply distorting the ring to engage or disengage the tongue and groove.

[0009] The groove can be u-shaped and the second axial face defines the base of the groove.

[0010] The axial thickness of the tongue can be substantially the same as the axial depth of the groove. In this way, the surface of the tongue can be substantially flush with the first axial face of the ring at the first end. This avoids any part projecting in a way that could catch or interfere with other components in use. The tongue can extend from the first axial face of the second end and can be set back from the second axial face of the second end. Thus, the first and second axial faces of the first and second ends can be aligned and flush.

[0011] The tongue can have parallel radial sides and a terminal end face. The tongue can comprise an angled edge between one of the radial sides of the tongue and the terminal end. This can aid in insertion of the tongue into the groove.

[0012] The length of the groove from the first end face can be greater than the length of the tongue extending from the second end face. This can avoid the end face of the tongue contacting the end of the groove and causing distortion or damage of one and/or the other.

[0013] The first and second end faces can be spaced apart when the tongue is received in the groove. This allows some relative movement of the end faces due to thermal expansion or contraction or other forces.

[0014] Another aspect of the invention comprises a method of assembling a ring fastener into a circumferential groove in a component, the method comprising the steps of:

feeding the ring fastener into the circumferential groove so that the first and second ends are adjacent to each other;

distorting the second end axially out of the plane of the circumferential groove;

bringing the first and second ends towards each other until the tongue overlies the groove; and

inserting the tongue into the groove so that the first and second ends are within the circumferential groove of the component.

BRIEF DESCRIPTION OF THE DRAWINGS

[0015] Fig. 1 shows a portion of an embodiment of a ring fastener in an interlocked position.

[0016] Fig. 2 shows a cross section on the line AA of Fig. 1.

[0017] Fig. 3 shows a perspective view of the portion shown in Fig. 1.

DETAILED DESCRIPTION OF EMBODIMENTS

[0018] The ring fastener shown in the drawings is essentially circular in shape. Only part of the ring is shown in the drawings.

[0019] The ring fastener shown in the drawing is typical of such fasteners used in turbines such as gas turbines for securing components, for example within bores. The fasteners will be made from alloys having suitable high temperature strength and oxidation resistance.

[0020] The fastener is formed from a metal strip 10 having a substantially rectangular cross section with rounded corners. The strip has axial faces and radial faces.

[0021] The strip does not form a complete circle, but instead is discontinuous, having opposed end faces 12, 14.

[0022] A first end 16 of the strip 10 is formed with a groove 18 which extends from an open end 20 at the first end face 12 and opens onto one of the axial surfaces 22. The other axial surface 24 defines the base of the groove 18 which is essentially u-shaped, the radial sides of the strip 26, 28 defining the sides of the groove 18. The closed end 30 of the groove 18 is radiused.

[0023] The second end 32 of the strip 10 is formed with a tongue 34 projecting from the second end face 14. The tongue 34 is substantially straight-sided and has a squared-off terminal end face 36. There is an angled edge 38 between one side 40 and the terminal end face 36. The tongue 34 is narrower than the width of the strip 10 and is dimensioned so as to be able to fit in the groove 18.

[0024] The tongue 34 is offset to one side of the second end 32 so that one face 42 of the tongue is flush with the axial face 22 of the strip 10. The other face 44 of the tongue is set back from the opposite axial face 24 of the strip 10. The thickness of the tongue 34 is about the same as the depth of the

groove 18 so that when the tongue 34 is seated in the groove 18, its face 42 is substantially flush with the axial face 22 of the first end 16.

[0025] In use, one end of the strip 10 will be fed into a groove in a component, such as a circumferential groove (not shown), and the strip 10 fed around the component until the two ends 16, 32 are close to each other. At this point, the second end 32 with the tongue 34 can be bent away from the plane of the circle and forced to lie over the first end 16 with the groove 18. The tongue 34 can then be urged into the groove 18, the angled edge 38 allowing the tongue 34 to clear the side of the groove 18. At this point, part of the tongue 34 will sit in the groove 18 so that the ring fastener presents a complete circumference but with the end faces 12, 14 separated by a small distance. The length of the tongue 34 is such that the terminal end face 36 of the tongue 34 will not contact the closed end 30 of the groove 18 even when the tongue 34 is fully inserted into the groove 18 and the end faces 12, 14 abut each other. The space between the end faces 12, 14 allows expansion or contraction due to temperature changes to be accommodated without displacing the ring from the groove.

[0026] Holes 46, 48 are provided in the face 22 of the strip near each end 16, 32 to allow the use of assembly tools (not shown) to manipulate the ends 16, 32 of the strip 10 so that the tongue 34 can be inserted into or removed from the groove 18.

[0027] The invention has been described above with reference to one specific embodiment. Various changes or modifications can be made without departing from the scope of the invention.

CLAIMS

1. A ring fastener comprising:
 - a discontinuous band having first and second axial faces on opposite sides,
 - a first end with a first end face and a groove extending from the first end face and opening to the first axial face;
 - a second end with a second end face and a tongue projecting from the second end face
 - wherein the tongue is dimensioned to fit in the groove;
 - such that, when the tongue is received in the groove, the first end is located relative to the second end and a continuous ring is formed.
2. A ring fastener as claimed in claim 1, wherein the groove is u-shaped and the second axial face defines the base of the groove.
3. A ring fastener as claimed in claim 1 or 2, wherein the axial thickness of the tongue is substantially the same as the axial depth of the groove.
4. A ring fastener as claimed in any preceding claim, wherein the tongue extends from the first axial face of the second end.
5. A ring fastener as claimed in claim 4, wherein the tongue is set back from the second axial face of the second end.

6. A ring fastener as claimed in any preceding claim, where the tongue has parallel radial sides and a terminal end face.
7. A ring fastener as claimed in any preceding claim, wherein the tongue comprises an angled edge between one of the radial sides of the tongue and the terminal end.
8. A ring fastener as claimed in any preceding claim, wherein the length of the groove from the first end face is greater than the length of the tongue extending from the second end face.
9. A ring fastener as claimed in any preceding claim, wherein the first and second end faces are spaced apart when the tongue is received in the groove.
10. A method of assembling a ring fastener as claimed in any preceding claim into a circumferential groove in a component, the method comprising the steps of:
 - feeding the ring fastener into the circumferential groove so that the first and second ends are adjacent to each other;
 - distorting the second end axially out of the plane of the circumferential groove;
 - bringing the first and second ends towards each other until the tongue overlies the groove; and
 - inserting the tongue into the groove so that the first and second ends are within the circumferential groove of the component.

Fig 1

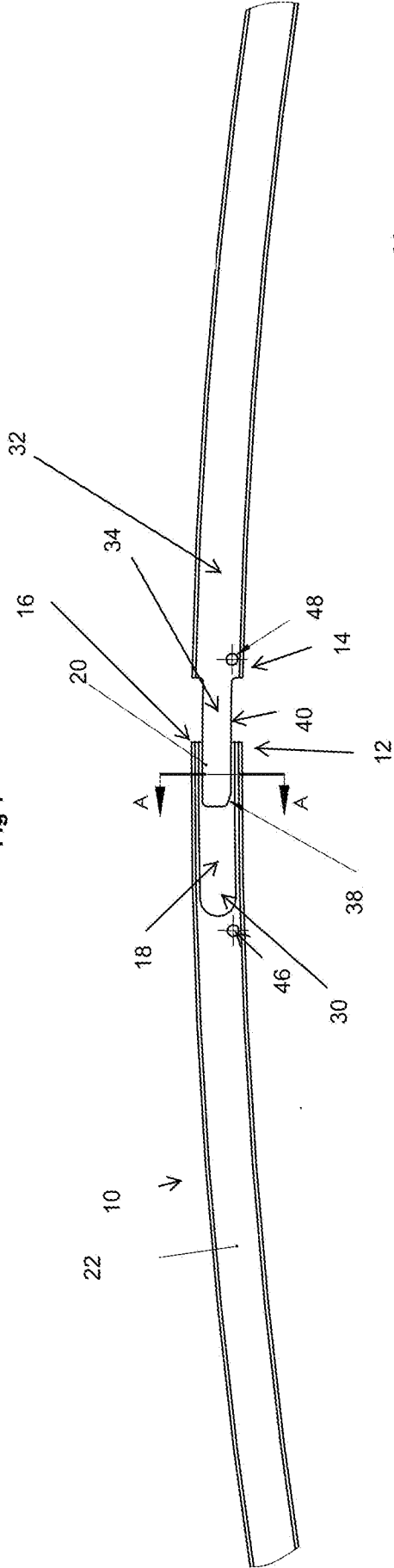

Fig 2

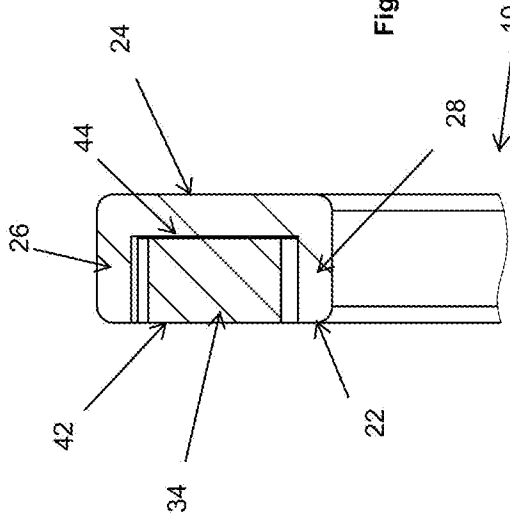
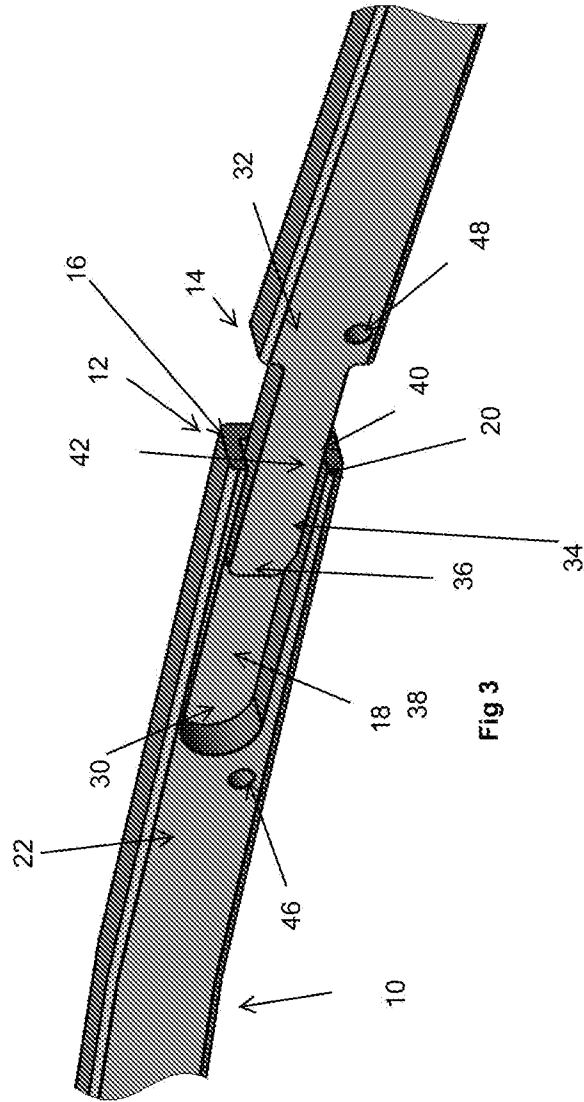

Fig 3



INTERNATIONAL SEARCH REPORT

International application No
PCT/GB2023/051603

A. CLASSIFICATION OF SUBJECT MATTER
INV. F16B21/18 F16B43/00
ADD.

According to International Patent Classification (IPC) or to both national classification and IPC

B. FIELDS SEARCHED

Minimum documentation searched (classification system followed by classification symbols)
F16B

Documentation searched other than minimum documentation to the extent that such documents are included in the fields searched

Electronic data base consulted during the international search (name of data base and, where practicable, search terms used)

EPO-Internal

C. DOCUMENTS CONSIDERED TO BE RELEVANT

Category*	Citation of document, with indication, where appropriate, of the relevant passages	Relevant to claim No.
X	GB 2 584 097 A (CROSS MFG 1938 LIMITED [GB]) 25 November 2020 (2020-11-25)	1, 4-7, 10
A	abstract page 10, line 1 - line 13 figures	2, 3, 8, 9

X	DE 10 2008 008983 A1 (ENERLYT TECHNIK GMBH [DE]) 20 August 2009 (2009-08-20)	1, 4-7, 10
A	abstract paragraphs [0012] - [0014] figures	2, 3, 8, 9

X	GB 515 230 A (WILLIAM ARTHUR OUBRIDGE) 29 November 1939 (1939-11-29)	1, 10
	abstract column 3, line 114 - line 126 figures with groove	

	-/--	

Further documents are listed in the continuation of Box C.

See patent family annex.

* Special categories of cited documents :

- "A" document defining the general state of the art which is not considered to be of particular relevance
- "E" earlier application or patent but published on or after the international filing date
- "L" document which may throw doubts on priority claim(s) or which is cited to establish the publication date of another citation or other special reason (as specified)
- "O" document referring to an oral disclosure, use, exhibition or other means
- "P" document published prior to the international filing date but later than the priority date claimed

- "T" later document published after the international filing date or priority date and not in conflict with the application but cited to understand the principle or theory underlying the invention
- "X" document of particular relevance; the claimed invention cannot be considered novel or cannot be considered to involve an inventive step when the document is taken alone
- "Y" document of particular relevance; the claimed invention cannot be considered to involve an inventive step when the document is combined with one or more other such documents, such combination being obvious to a person skilled in the art
- "&" document member of the same patent family

Date of the actual completion of the international search

22 September 2023

Date of mailing of the international search report

02/10/2023

Name and mailing address of the ISA/
 European Patent Office, P.B. 5818 Patentlaan 2
 NL - 2280 HV Rijswijk
 Tel. (+31-70) 340-2040,
 Fax: (+31-70) 340-3016

Authorized officer

Vermander, Wim

INTERNATIONAL SEARCH REPORT

International application No
PCT/GB2023/051603

C(Continuation). DOCUMENTS CONSIDERED TO BE RELEVANT		
Category*	Citation of document, with indication, where appropriate, of the relevant passages	Relevant to claim No.
X	EP 2 028 398 A1 (CROSS MFG CO 1938 LTD [GB]) 25 February 2009 (2009-02-25) abstract paragraphs [0014] - [0016] figures -----	1, 10
X	GB 744 456 A (SZIGETI ELEMÉR) 8 February 1956 (1956-02-08) the whole document -----	1, 10
X	US 2010/278587 A1 (MASKELL BRUCE W [US]) 4 November 2010 (2010-11-04) abstract paragraph [0048] figures -----	1, 10
X	DE 10 2012 206676 A1 (ZAHNRADFABRIK FRIEDRICHSHAFEN [DE]) 24 October 2013 (2013-10-24) abstract paragraph [0041] figures -----	1, 10
X	US 2022/065280 A1 (ZUBER KENNETH B [US]) 3 March 2022 (2022-03-03) abstract paragraph [0048] figures -----	1, 10

INTERNATIONAL SEARCH REPORT

Information on patent family members

International application No

PCT/GB2023/051603

Patent document cited in search report	Publication date	Patent family member(s)	Publication date	
GB 2584097	A	25-11-2020	CA 3141441 A1	26-11-2020
			EP 3973148 A1	30-03-2022
			GB 2584097 A	25-11-2020
			GB 2584171 A	25-11-2020
			JP 7209870 B2	20-01-2023
			JP 2022530277 A	28-06-2022
			US 2022268163 A1	25-08-2022
			WO 2020234572 A1	26-11-2020

DE 102008008983	A1	20-08-2009	NONE	

GB 515230	A	29-11-1939	NONE	

EP 2028398	A1	25-02-2009	CN 101372923 A	25-02-2009
			EP 2028398 A1	25-02-2009
			JP 2009052543 A	12-03-2009
			US 2009051117 A1	26-02-2009

GB 744456	A	08-02-1956	NONE	

US 2010278587	A1	04-11-2010	CA 2672838 A1	07-10-2009
			US 2010278587 A1	04-11-2010

DE 102012206676	A1	24-10-2013	CN 104246324 A	24-12-2014
			DE 102012206676 A1	24-10-2013
			EP 2841824 A1	04-03-2015
			JP 6246790 B2	13-12-2017
			JP 2015518554 A	02-07-2015
			US 2015048573 A1	19-02-2015
			WO 2013159984 A1	31-10-2013

US 2022065280	A1	03-03-2022	CN 114198371 A	18-03-2022
			US 2022065280 A1	03-03-2022
