



(22) Date de dépôt/Filing Date: 2000/10/27

(41) Mise à la disp. pub./Open to Public Insp.: 2002/04/27

(51) Cl.Int.<sup>7</sup>/Int.Cl.<sup>7</sup> A63C 1/00, A43B 7/32, A43B 5/16

(71) Demandeur/Applicant:  
BLOIS, DAVID A., CA

(72) Inventeur/Inventor:  
BLOIS, DAVID A., CA

(74) Agent: FINLAYSON & SINGLEHURST

(54) Titre : PATINS A GLACE A SUSPENSION

(54) Title: ICE SKATE WITH SUSPENSION

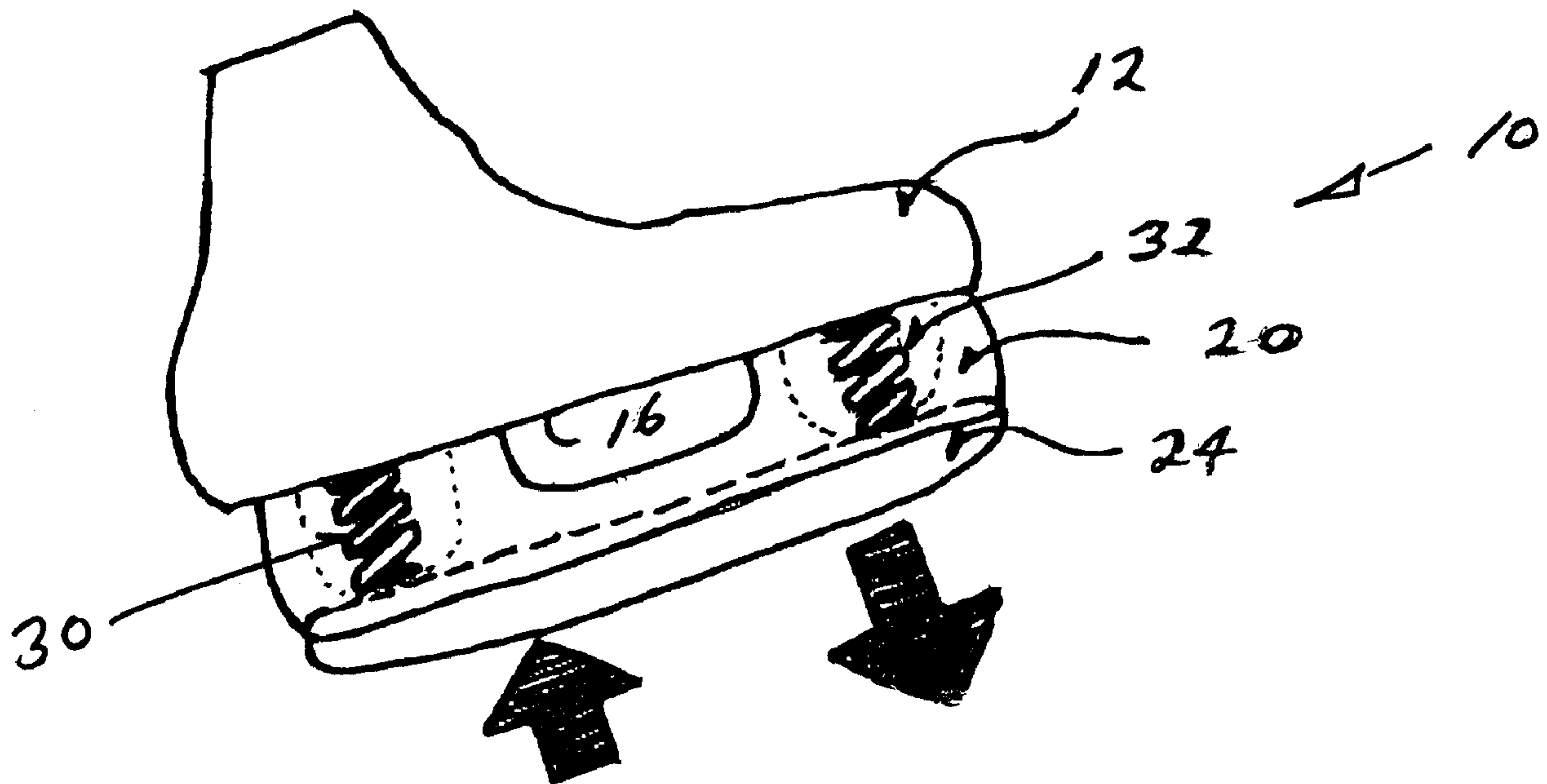

(57) Abrégé/Abstract:

Disclosed is to an improved ice skate with suspension between the skate boot and the blade in a blade runner/holder housing in order to utilize kinetic energy generated during various skating motions to increase the speed of such skating motions and as well to provide more comfort to the wearer of the skates. The suspension is intended to be accomplished with either coil, or leaf type springs mounted between the bottom of the skate boot and the blade runner/ holder and the suspension is to be enclosed in the blade runner/holder housing so as to protect the suspension assembly from damage and to provide for a safe overall skate construction.

## **ICE SKATE WITH SUSPENSION**

### **ABSTRACT OF THE DISCLOSURE**

Disclosed is to an improved ice skate with suspension between the skate boot and the blade in a blade runner/holder housing in order to utilize kinetic energy generated during various skating motions to increase the speed of such skating motions and as well to provide more comfort to the wearer of the skates. The suspension is intended to be accomplished with either coil, or leaf type springs mounted between the bottom of the skate boot and the blade runner/holder and the suspension is to be enclosed in the blade runner/holder housing so as to protect the suspension assembly from damage and to provide for a safe overall skate construction.

## **ICE SKATE WITH SUSPENSION**

### **FIELD OF THE INVENTION**

The invention relates to ice skates and more particularly to ice skates with a suspension for the blade of the skates.

### **BACKGROUND OF THE INVENTION**

Spring loaded blades in association with skates have conceptionally been known since at least as early as 1862, Ansley, U.S. patent No. 36,595. U.S. patent No. 4,993,725, February 19, 1991 to BARNES ET AL discloses a vertical spring assembly for a skate blade.

Nevertheless, generally all ice skates currently in use, including pleasure skates, hockey skates, figure skates and speed skates are very rigid in construction in respect of the connection between the skate boot and blade runner/holder housing, with the exception of the "Clap" or "Slap" style speed skates, which incorporate a spring-hinged mechanism to essentially permit the skate blade to remain in contact with the ice surface for a longer duration, resulting in increased skating speed. The spring component of this unique speed skate is utilized to facilitate the return of the blade runner/holder to the heel of the skater's boot at the completion of each full stride, but it does not provide any suspension between the boot and the blade runner/holder housing.

It would be advantageous to provide an improved suspension system between the blade runner/holder housing for ice skates and the boot portion of the skate.

### **SUMMARY OF THE INVENTION**

My invention relates to an improved ice skate with suspension between the skate boot and the blade in a blade runner/holder housing in order to utilize kinetic energy generated during various skating motions (such as, but not limited to turning and the initial "push off" portion of the skater's stride) to increase the speed of such skating motions, to reduce pressure and tension which can lead to groin, knee, hip flexors and extensor injuries that are often caused by

overuse or extension and as well to provide more comfort to the wearer of the skates. The suspension is intended to be accomplished with either coil, or leaf type springs mounted between the bottom of the skate boot and the blade runner/holder housing. The suspension is preferably enclosed in the blade runner/holder housing so as to protect the suspension assembly from damage and to provide for a safe overall skate construction in order to comply with the current rules for equipment imposed by the National Hockey League, (NHL), the Canadian Hockey Association (CHA) and other skating organizations.

In one broad aspect the invention provides an ice skate having a boot portion with an outer bottom surface, a blade holder housing and a blade, the blade holder housing having an upper portion and a lower portion and the upper housing portion having means for securement of the blade holder housing to the boot bottom surface. The lower blade holder housing portion has an elongate groove substantially the length of the lower blade holder housing portion, which groove is configured and sized to permit limited vertical reciprocal movement of an upper portion of the blade within the groove in the direction of the boot. The blade holder housing portion having longitudinal spaced hollow well means and means are secured to the blade and extend upwardly into the spaced well means, which blade secured means cooperate with lower portions of the well means to limit outward movement of the blade within the groove. Spring means is within the housing and associated with the blade to normally force the blade outwardly and wherein, inward movement of the upper portion of the blade within the groove is against the force of the spring means.

#### **BRIEF DESCRIPTION OF THE DRAWINGS**

Figure 1 is a side view of a skate according to a first embodiment of the invention.

Figure 2 is a side view of another embodiment of the invention.

Figure 3 is an exploded perspective schematic view of the blade runner/holder housing and blade of the first embodiment of the invention.

**DESCRIPTION OF PREFERRED EMBODIMENTS OF THE INVENTION**

Turning to Figure 1 and Figure 2, there are shown a skate 10 with boot 12 having a bottom 16, blade runner/holder housing 20 and blade 24. In the Figure 1 embodiment, there is shown the use of coil springs 30, 32 in the blade runner/holder housing 20. The embodiment of Figure 2 illustrates the use of a leaf spring 40 in the blade runner/holder housing 20.

A minimum of two (2) coil springs 30, 32 or one (1) leaf spring 40 would be mounted between the boot bottom 16 and the blade 24 in the blade runner/holder housing 20, to permit the skate blade 24 to move specifically only vertically up and down, either independently at each end of the skate, or uniformly, depending on the forces applied and the angles of such forces, as it is compressed by the skater's weight and force and released as the skate lifts off the ice surface. The blade runner/holder housing 20 is to be made of strong injection moulded plastic such as "Zytel", or other similar plastics being used in present day runner/blade housings, or any other suitably strong material which can be moulded or formed to create a strong, but light housing.

The compression strength of the coil spring(s) 30, 32 or leaf spring 40 would be matched to a certain weight range and therefore a different spring(s) would be used for each weight range. If more than one (1) spring is used, as in the case of coil springs 30, 32, the compression strength of each spring used in each blade runner/holder housing 20 would be equal, or identical springs would be utilized.

The blade 24 is held in place horizontally along its length by a channel of corresponding width in the blade runner/holder housing 20, with very tight tolerances to negate any side to side or bending movement of the blade.

In a prototype of my invention, I employed a modified holder and blade, (relating to the TUUK blade), as shown in Figure 3 of U.S. patent No. 4,074,909 and reproduced as Figure 3 herein but with revised reference numerals. In my prototype, groove 50 is extended vertically upwards for the entire length of the thermoplastic blade runner/holder housing 20 in order for blade 24 to move up and down in the housing 20. Bolts 54 which, in my prototype, were larger and longer in length than those illustrated in Figure 3 were

welded to blade 24 and are reciprocal in housing bores 50. Larger nuts 56 were threaded down on bolts 54 to limit the downward travelling distance of blade 24 within groove 50. High compression coil springs 32 were mounted over each of the bolts 54 within housing wells 58 such that the springs 32 were held in place at the bottom by the housing 20 about bores 50 for bolts 54 and at the top by the underside of the boot, (not shown in Figure 3). The upward travel of the blade is controlled by the compression strength of the coil springs 32.

It will be appreciated that a modified design can accommodate a leaf spring rather than coil springs. As schematically noted in Figure 2, with bolts 70 welded to blade 24 and extending upwardly through groove 72, internal bores 74 in housing 20, which housing has wells similar to those shown in Figure 3. Leaf spring 40 has apertures through which bolts 70 extend and is held between the top 80 of the groove 72 and the top of blade 24.

This invention is intended for adaptation in all classifications of skating, including pleasure, hockey, figure and speed skating. The construction of this invention can be used in place of the spring-hinged construction in speed skates. The type of blade, its length and construction, would be matched to the classification of skating and the blade runner/holder housing and suspension assembly would be altered accordingly to house the appropriate blade. In the case of speed skating for example, the blade would be of the same length used in present day speed skates.

When a downward force is applied to the skate blade, kinetic energy is stored and the kinetic energy is released as each skate is lifted off the ice. The skates of this invention facilitate faster skating motions utilizing kinetic energy, reduce stress/strain/pressure on legs and associated joints (and thereby may reduce muscle/joint pain and injuries) and generally provide a more comfortable skate, somewhat akin to the feeling of driving in a car with shock absorbers versus in one without shock absorbers.

**CLAIMS:**

1. An ice skate having a boot portion with an outer bottom surface, a blade holder housing and a blade, said blade holder housing having an upper portion and a lower portion, said upper housing portion having means for securement of said blade holder housing to said boot bottom surface, said lower blade holder housing portion having an elongate groove substantially the length of said lower blade holder housing portion, which groove is configured and sized to permit limited vertical reciprocal movement of an upper portion of said blade within said groove in the direction of said boot;

said blade holder housing portion having longitudinal spaced hollow well means and means secured to said blade and extending upwardly into said spaced well means, which cooperate with lower portions of said well means to limit outward movement of said blade within said groove; and

spring means within said housing and associated with said blade to normally force said blade outwardly and wherein, inward movement of the upper portion of said blade within said groove is against the force of said spring means.

2. The ice skate of claim 1 wherein said spring means comprises a compression coil spring within each well means.

3. The ice skate of claim 1 wherein said spring means comprises a leaf spring.

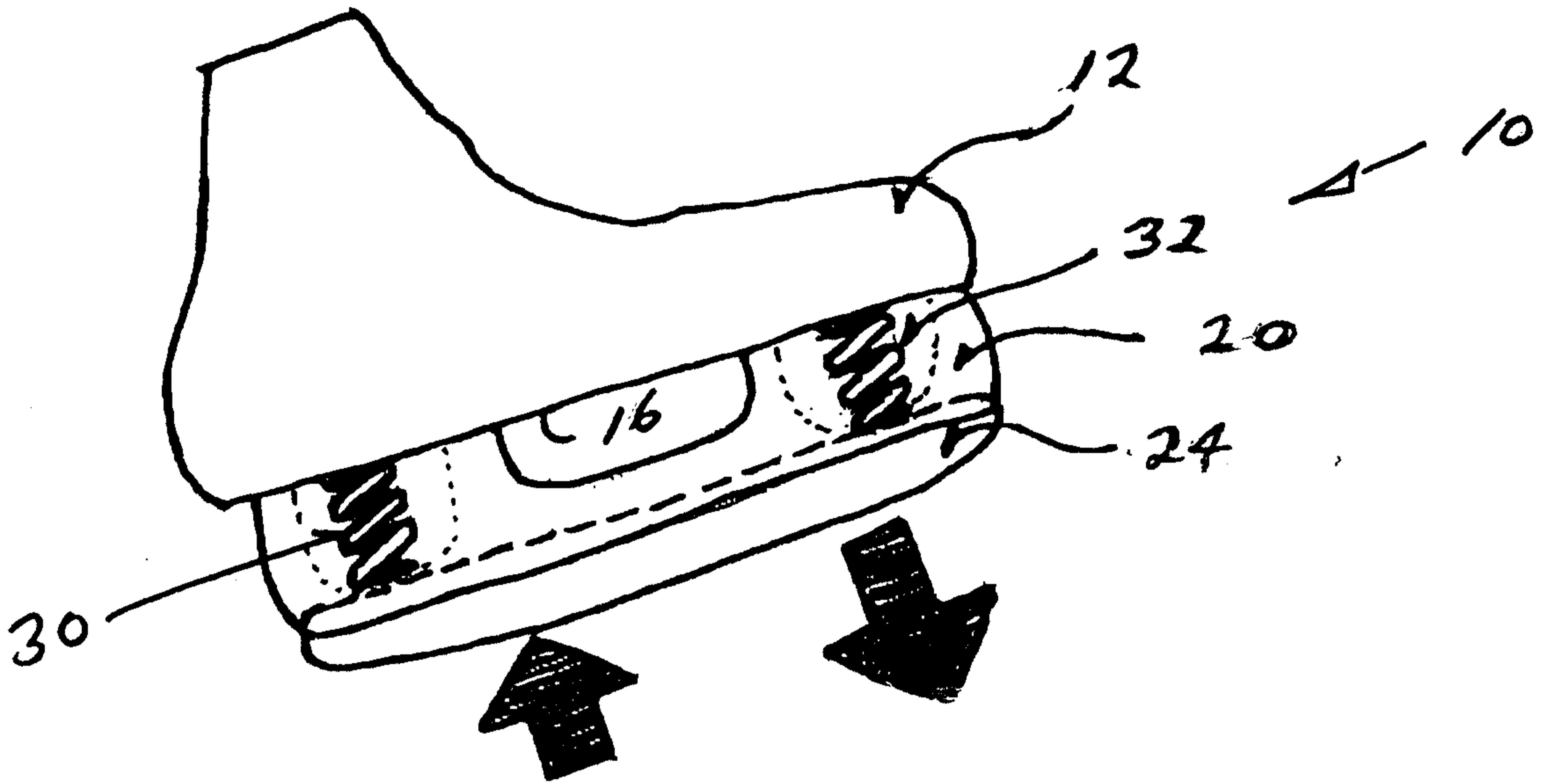

FIG. 1

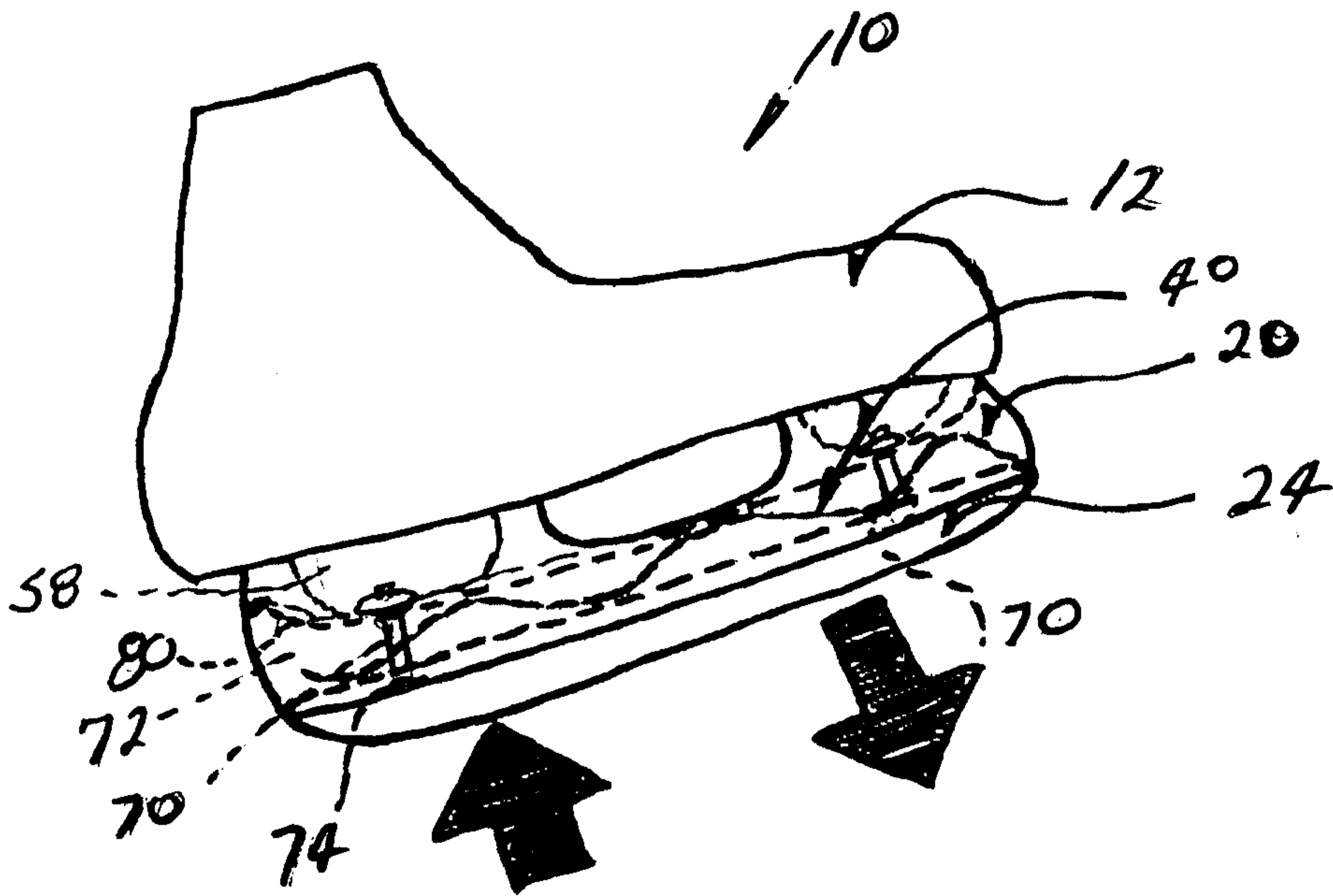
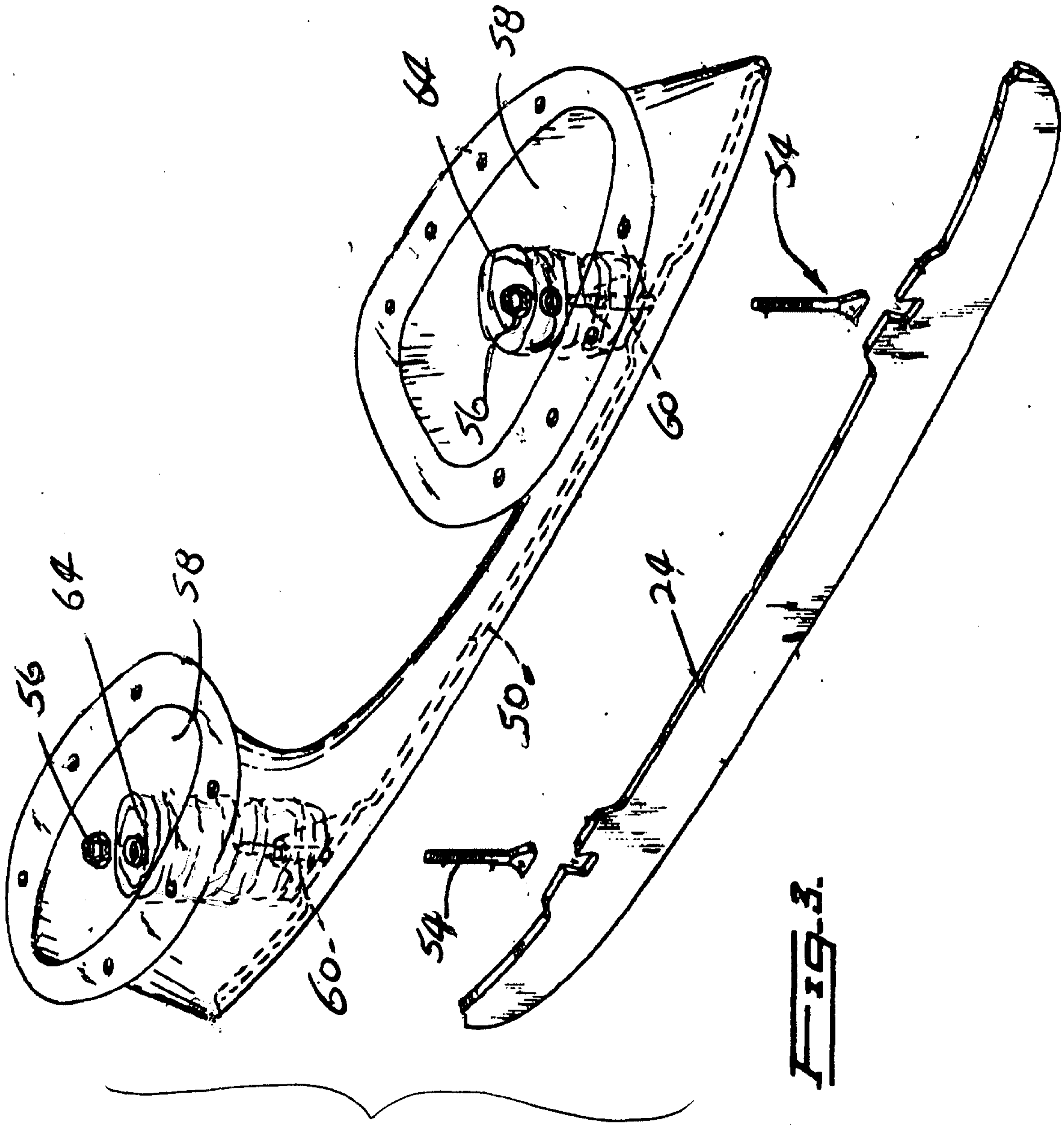

FIG. 2



*Fuller & Co. Inc.*  
PATENT AGENTS

