

(19) World Intellectual Property
Organization
International Bureau



(43) International Publication Date
10 September 2004 (10.09.2004)

PCT

(10) International Publication Number
WO 2004/075791 A1

(51) International Patent Classification⁷: **A61F 2/06**, 2/01

(21) International Application Number:
PCT/US2004/003812

(22) International Filing Date: 9 February 2004 (09.02.2004)

(25) Filing Language: English

(26) Publication Language: English

(30) Priority Data:
10/374,854 26 February 2003 (26.02.2003) US

(71) Applicant (for all designated States except US): **SCIMED LIFE SYSTEMS, INC.** [US/US]; One Scimed Place, Maple Grove, MN 55311-1566 (US).

(72) Inventor: **ELLIOTT, Christopher, J.**; 74 Ash Street, Hopkinton, MA 01748 (US).

(74) Agent: **PRESTIA, Paul, F.**; RatnerPrestia, P.O. Box 980, Valley Forge, PA 19482 (US).

(81) Designated States (unless otherwise indicated, for every kind of national protection available): AE, AG, AL, AM, AT, AU, AZ, BA, BB, BG, BR, BW, BY, BZ, CA, CH, CN, CO, CR, CU, CZ, DE, DK, DM, DZ, EC, EE, EG, ES, FI, GB, GD, GE, GH, GM, HR, HU, ID, IL, IN, IS, JP, KE, KG, KP, KR, KZ, LC, LK, LR, LS, LT, LU, LV, MA, MD, MG, MK, MN, MW, MX, MZ, NA, NI, NO, NZ, OM, PG, PH, PL, PT, RO, RU, SC, SD, SE, SG, SK, SL, SY, TJ, TM, TN, TR, TT, TZ, UA, UG, US, UZ, VC, VN, YU, ZA, ZM, ZW.

(84) Designated States (unless otherwise indicated, for every kind of regional protection available): ARIPO (BW, GH, GM, KE, LS, MW, MZ, SD, SL, SZ, TZ, UG, ZM, ZW), Eurasian (AM, AZ, BY, KG, KZ, MD, RU, TJ, TM), European (AT, BE, BG, CH, CY, CZ, DE, DK, EE, ES, FI, FR, GB, GR, HU, IE, IT, LU, MC, NL, PT, RO, SE, SI, SK, TR), OAPI (BF, BJ, CF, CG, CI, CM, GA, GN, GQ, GW, ML, MR, NE, SN, TD, TG).

Published:
— with international search report

For two-letter codes and other abbreviations, refer to the "Guidance Notes on Codes and Abbreviations" appearing at the beginning of each regular issue of the PCT Gazette.

(54) Title: ENDOLUMINAL DEVICE HAVING ENHANCED AFFIXATION CHARACTERISTICS

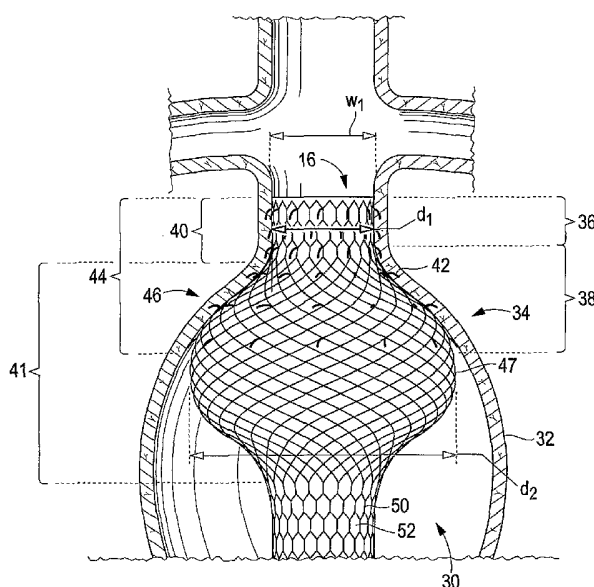

(57) Abstract: An endoluminal device (30) for affixation to a wall of a body lumen (32) having a neck region (36) defined by a relatively narrow width and a shoulder region (38) that diverges from the neck region to a relatively wider width. The device comprises a shoulder portion (46), which may be part of a bulbous portion, having a diameter profile that conforms to the shoulder region, and, in some embodiments, a plurality of affixation members (42) in an area of the device that typically extends from a distal end (16) of the device (30) through the shoulder portion (46). In one embodiment, the device comprises an endograft (52) for repair of an aneurysm, such as an abdominal aortic aneurysm (AAA). Methods of using the endograft (52) to inhibit continued diametric expansion of the aneurysm and to inhibit endoleak formation and migration of the endograft are also described.

WO 2004/075791 A1

- 1 -

ENDOLUMINAL DEVICE HAVING
ENHANCED AFFIXATION CHARACTERISTICS

FIELD OF THE INVENTION

This invention relates generally to endoluminal devices, particularly stents and grafts for placement in an area of a body lumen that has been weakened by damage or disease, such as an aneurysm of the abdominal aorta, and more particularly to devices having characteristics that enhance affixation of the devices to the body lumen.

BACKGROUND OF THE INVENTION

Medical devices for placement in a human or other animal body are well known in the art. One class of medical devices comprises endoluminal devices such as stents, stent-grafts, filters, coils, occlusion baskets, valves, and the like. A stent is an elongated device used to support an intraluminal wall. In the case of a stenosis, a stent provides an unobstructed conduit through a body lumen in the area of the stenosis. Such a stent may also have a prosthetic graft layer of fabric or covering lining the inside and/or outside thereof. A covered stent is commonly referred to in the art as an intraluminal prosthesis, an endoluminal or endovascular graft (EVG), a stent-graft, or endograft.

An endograft may be used, for example, to treat a vascular aneurysm by removing the pressure on a weakened part of an artery so as to reduce the risk of rupture. Typically, an endograft is implanted in a blood vessel at the site of a stenosis or aneurysm endoluminally, i.e. by so-called "minimally invasive techniques" in which the endograft, typically restrained in a radially compressed configuration by a sheath, crocheted or knit web, or catheter, is delivered by a stent delivery system or "introducer" to the site where it is required. The introducer may enter the body from an access location outside the body, such as through the patient's skin, or by a "cut down" technique in which the entry blood vessel is exposed by minor surgical means. The term "proximal" as used herein refers to portions of the stent or delivery system relatively closer to the end outside of the body, whereas the term "distal" is used to refer to portions relatively closer to the end inside the body.

After the introducer is advanced into the body lumen to the endograft deployment location, the introducer is manipulated to cause the endograft to be deployed from its constrained configuration, whereupon the stent is expanded to a predetermined diameter at the deployment location, and the introducer is withdrawn.

- 2 -

Stent expansion is typically effected by spring elasticity, balloon expansion, and/or by the self-expansion of a thermally or stress-induced return of a memory material to a pre-conditioned expanded configuration.

Among the many applications for endografts is that of deployment in lumen for repair of an aneurysm, such as an abdominal aortic aneurysm (AAA). An AAA is an area of increased aortic diameter that generally extends from just below the renal arteries to the aortic bifurcation. AAA generally results from deterioration of the arterial wall, causing a decrease in the structural and elastic properties of the artery. In addition to a loss of elasticity, this deterioration also causes a slow and continuous dilation of the lumen.

The standard surgical repair of AAA is an extensive and invasive procedure typically requiring a weeklong hospital stay and an extended recovery period. To avoid the complications of the surgical procedure, practitioners commonly resort to a minimally invasive procedure using endoluminal endograft to reinforce the weakened vessel wall, as mentioned above. At the site of the aneurysm, the practitioner deploys the endograft, anchoring it above and below the aneurysm to relatively healthy tissue. The anchored endograft diverts blood flow away from the weakened arterial wall, minimizing the exposure of the aneurysm to high pressure.

Intraluminal stents for repairing a damaged or diseased artery or to be used in conjunction with a graft for delivery to an area of a body lumen that has been weakened by disease or damaged, such as an aneurysm of the abdominal aorta, are well established in the art of medical science. Intraluminal stents having barbs, hooks, or other affixation means to secure the stents to the wall of the lumen in which they are to be deployed are also well known in the art. Referring now to Fig. 1, there is shown an exemplary embodiment of an endograft 10 comprising a stent 11 having a graft lining 12 and a plurality of hooks 13 for affixation to the wall 14 of aorta 15 afflicted with an aneurysm. The affixation means, such as hooks 13, are important because subsequent movement (or "migration") of the endograft may cause the aneurysm to become exposed to blood pressure. In particular, if the device migrates proximally over time in the direction of arrow A, as shown in Fig. 1, a leak at distal end 16 of the device, sometimes referred to in the art as a "Type I endoleak," may cause blood to flow undesirably to the aneurysm.

Even with standard affixation means, however, continued progression of the aneurysm may lead to diametric expansion of the aneurysm along arrows B as shown in Fig. 1. In particular, in AAA applications, the portion of the aneurysm closest

- 3 -

to the renal arteries 17, referred to herein as the "renal neck" 18, may undergo this diametric expansion. The "renal neck" is often referred to by practitioners as the "proximal neck" where the term "proximal" means anatomically as closer to the heart. Because this application does not use anatomical definitions of "proximal" and "distal,"
5 the term "renal neck" is used herein avoid confusion. This diametric expansion of the renal neck may result in ineffective engagement of one or more of the hooks around the circumference of the renal neck, and may lead to a Type I endoleak, as illustrated by separation 20 between aorta wall 14 and endograft 10 in Fig. 2, and/or distal migration of the endograft.

10 Accordingly, it can be seen that while the art has advanced the use of barbs to minimize migration of a deployed stent-graft, even the use of such barbs may not be sufficient to prevent endoleaks. Accordingly, there is still a need in the art for endograft designs having enhanced affixation characteristics.

SUMMARY OF THE INVENTION

15 The foregoing general description and subsequent detailed description are representative, not restrictive, of the invention.

One aspect of the invention comprises an endoluminal device for affixation to a wall of a body lumen having a neck region defined by a relatively narrow width and a shoulder region that diverges from the neck region to a relatively wider
20 width. The device comprises a shoulder portion, having a diameter profile that conforms to the shoulder region, such as a shoulder portion having a bulbous geometry, for deployment in the shoulder region. At least part of the shoulder region may further comprise a plurality of affixation members, including but not limited to hooks, barbs, or other members that project radially outward from the device. In one
25 embodiment, the device comprises an endograft comprising a stent that is at least partially covered or lined with a graft material, for example, an endograft adapted to repair an aneurysm such as an AAA. The endoluminal device typically comprises a compressed configuration and a radially expanded configuration, and in at least one
30 embodiment, the device neck has a first radial self-expansion force and the bulbous portion has a second radial self-expansion force less than the first radial expansion force.

Another aspect of the invention comprises an endograft for repair of an AAA. The endograft comprises a stent at least partially lined or covered by a graft material and having enhanced affixation characteristics, the endograft having a first

- 4 -

end comprising a distal neck having a first diameter and a shoulder portion located adjacent the distal neck and having a diverging then converging diameter greater than the first diameter. At least the distal neck and part of the shoulder portion may comprise a plurality of affixation members that project radially outward from the device for affixation to the lumen wall of the AAA. The plurality of affixation members are typically disposed in an area of the endograft that extends axially from the distal end of the endograft to at least an intermediate location in the bulbous portion, and in one embodiment, to a maximum diameter portion of the bulbous portion. In one embodiment, the endograft may further comprise a proximal end comprising at least one proximal neck having a second diameter and a second bulbous portion located distally of the proximal neck and having a distally diverging then converging diameter greater than the second diameter, at least the proximal neck and part of the second bulbous portion comprising a plurality of affixation members that project radially outward from the device for affixation to the lumen wall of the AAA.

Yet another aspect of the invention comprises a method for inhibiting diametric expansion of an aneurysm. The method comprises deploying an endograft in the aneurysm, the endograft having an endograft neck with a diameter approximately equal to the width of the aneurysm neck region and a bulbous portion having at least a distal portion adapted to match a proximally diverging width of the shoulder region of the aneurysm, wherein the endograft neck and the distal portion of the bulbous portion comprise a plurality of affixation members for affixing to the lumen wall of the aneurysm.

Still another aspect of the invention comprises a method of inhibiting endoleak formation and migration of an endograft deployed in a lumen, the lumen having a lumen wall, a lumen neck region having a lumen neck width, and a lumen shoulder region proximal the lumen neck region having a proximally diverging width greater than the lumen neck region width. The method comprises providing the endograft with an endograft neck having a diameter approximately equal to the lumen neck region diameter and a shoulder portion adapted to match the proximally diverging diameter of the lumen shoulder region. The method may further comprise providing the endograft neck and the distal portion of the shoulder portion with a plurality of affixation members for affixing to the lumen wall. The shoulder portion may be provided as part of a bulbous portion.

An additional aspect of the invention comprises a method of repairing a body lumen having a lumen wall, a lumen neck region having a lumen neck width, and a lumen shoulder region proximal the lumen neck region having a proximally diverging

- 5 -

width greater than the lumen neck region width. The method comprises the steps of providing an endograft having the shoulder portion, bulbous portion and affixation members as described herein and having an expanded configuration and a compressed configuration; constraining the endograft in the compressed configuration for
5 introduction into the body lumen; advancing the endograft to a deployment location aligned with the lumen neck region and lumen shoulder region; and deploying the endograft so that one or more of the affixation members attached to the endograft neck affix to the lumen neck region and one or more of the affixation members attached to the shoulder portion affix to at least a portion of the lumen shoulder region.
10 The method may be used for repairing an aneurysm, such as an AAA. Where the endograft comprises a self-expanding stent having at least a partial covering or lining of a graft material, the method may comprise the stent exerting a radial expansion force against the lumen wall in the neck region that is greater than the radial expansion force exerted by the bulbous portion. Where the endograft comprises a modular device
15 having at least two modular components -- a first modular component comprising a distal bulbous region and one or more second modular components each comprising a proximal bulbous region -- the method may comprise deploying the first modular component and deploying the one or more second modular components to mate with the first modular component.

20

BRIEF DESCRIPTION OF THE DRAWING

The invention is best understood when the following detailed description is read with reference to the attached drawing, in which:

25 Fig. 1 is an illustration of a cross-section of an abdominal aortic aneurysm (AAA), showing a plan view of an exemplary endograft of the prior art deployed therein;

Fig. 2 is a cross-sectional illustration of the endograft and aorta of Fig. 1 taken across line 2-2, illustrating a Type I endoleak;

30 Fig. 3 is a plan view of an exemplary endoluminal device having a distal bulbous portion deployed in renal neck and shoulder region of an AAA shown in cross-section;

Fig. 4 is a plan view of another exemplary endoluminal device of the present invention comprising a plurality of proximal bulbous portions deployed in the iliac neck and shoulder regions of an AAA shown in cross-section; and

Fig. 5 is a flowchart depicting an exemplary method of the invention.

- 6 -

DETAILED DESCRIPTION OF THE INVENTION

The invention will next be illustrated with reference to the figures wherein the same numbers indicate similar elements in all figures. Such figures are intended to be illustrative rather than limiting and are included herewith to facilitate the explanation of the apparatus of the present invention.

Referring now to Fig. 3, there is shown an endoluminal device 30 for affixation to the lumen wall 32 of diseased aorta 34 that is afflicted with an aneurysm. Diseased aorta 34 comprises a neck region 36 defined by a relatively narrow width w_1 , and a shoulder region 38 that diverges from the neck region to a relatively wider width greater than w_1 . Device 30 comprises a device neck 40 (also referred to herein as "distal neck" in reference to Fig. 3 and "endograft neck") having a relatively constant diameter d_1 along its length and a bulbous portion 41 having a proximally diverging then converging diameter greater than diameter d_1 along its length. It should be noted that although the term "diameter" is used herein, the invention is not limited to embodiments having a perfectly circular cross-section. Thus, the term "diameter" should be interpreted to refer to the "effective diameter" of non-circular cross-sections, meaning an average of the width across the device at a given axial plane. At least the distal, shoulder portion 46 of bulbous portion 41 conforms to the contour of shoulder region 38. A plurality of affixation members 42 are disposed throughout an affixation area 44 that spans proximally from the distal or upstream end 16 of the device, through neck 40 and through at least distal portion 46 of bulbous portion, preferably to an intermediate location in the bulbous portion, such as to maximum diameter portion 47 having a diameter d_2 . The affixation members typically comprise hooks, barbs, other members that project radially outward from the device, or any type of member known in the art for affixing an endoluminal device to a lumen wall.

Endoluminal device 30 as shown in Fig. 3 is an endograft comprising a stent 50 and a graft 52, which is shown in Fig. 3 as a lining on the radial inside surface of the stent. As is well known in the art, the graft material may also be provided as a covering on the radial outside surface of the stent. In some embodiments, the stent may comprise a self-expanding stent as is known in the art. Because of the weakened structure of the diametrically expanded walls of the aneurysm, in some embodiments it may be particularly advantageous for self-expanding stents to exert a lesser radial self-expansion force at bulbous portion 41 than at distal neck 40. This difference in radial self-expansion force between the two areas may be important to minimize the risk of rupture during device placement.

The difference in radial self-expansion force may be provided by providing different stent geometries or stent architectures in the different portions of the stent. Methods of providing different properties in different portions of a stent are described in U.S. Patent Application Serial No. 09/442,192 ("the '192 Application"),
5 filed November 16, 1999, titled ENDOLUMINAL STENT HAVING A MATCHED STIFFNESS REGION AND/OR A STIFFNESS GRADIENT AND METHODS FOR PROVIDING STENT KINK RESISTANCE and in U.S. Patent Application Serial No. 09/442,165 ("the '165 Application"), filed November 16, 1999, titled MULTI-SECTIONAL FILAMENTARY
10 ENDOLUMINAL STENT, both of which are incorporated herein by reference. For example, as detailed in the '192 Application, different stent geometries and/or architectures may be used to provide portions having different radial strength, which in turn exert different amounts of radial force. Specifically, a wound stent architecture, such as the hexagonal cell architecture shown in Fig. 3, may be provided in neck 40 and a braided architecture may be provided in bulbous portion 41, in accordance with
15 the hybrid wound/braided stents discussed generally in the '165 Application. Exemplary structures and methods for providing affixation members on stents are described in U.S. Patent Application Serial No. 10/153,351, filed on May 22, 2002, by James Weldon and Zarouhi Minasian and titled ENDOLUMINAL DEVICE HAVING BARB ASSEMBLY AND METHOD OF USING SAME, incorporated herein by reference. In
20 particular, the '351 application describes structures for providing affixation members for braided portions of hybrid wound/braided stents and at the intersection of a braided portion and a wound portion.

Fig. 3 shows only a distal portion of endograft 30, which may comprise a trunk section of a bifurcated device that has two proximal legs for repairing an
25 abdominal aortic aneurysm (AAA). The invention is not limited, however, to any particular type of device or application. For example, the proximal portion of endograft 30 (not shown) may not branch into any legs, may have more than two legs or branches, may be a modular design comprising one leg and female member for receiving a second leg, or may have any design known in the art. Furthermore, a
30 bulbous portion with affixation members may be provided as part of any type of endoluminal device in addition to use with endografts, such as but not limited to stents without a graft covering or lining, filters, coils, occlusion baskets, valves, and the like. Although endograft 30 is shown repairing an AAA, an endograft having a bulbous portion with affixation members may also be beneficial for repairing a thoracic aortic
35 aneurysm (TAA) or an aneurysm in any location in the body. The use of a bulbous

portion with affixation members may also prove beneficial in non-aneurysmal applications having a geometry that can benefit from the bulbous geometry.

Deploying an endograft as described herein in an aneurysm may advantageously inhibit diametric expansion of the aneurysm by radially fixturing the marginally diseased tissue in the shoulder region of the aneurysm. By preventing or at least delaying continued diametric expansion of the shoulder region, the endograft may thereby inhibit progression of the disease and better prevent a rupture of the aneurysm. The increase in length of endograft engagement along the aortic wall also inhibits endoleak formation by providing improved migration resistance and better sealing as compared to endografts lacking the bulbous portion. Furthermore, the increased affixation area provides a longer path for Type 1 endoleaks to travel prior to entering and subsequently repressurizing the aneurysmal sac. The longer pathway thus increases the chance of spontaneous endoleak stagnation and thrombosis which may repair the endoleak without need for surgical intervention or other remedial measures. The logic followed by the present invention is that it is more beneficial to minimize the risk of subsequent aneurysmal rupture than to restore the original cylindrical aortic geometry. The exertion of less radial force by bulbous portion 41 of endograft 30 than by neck 40 is consistent with this logic, because the lesser radial force minimizes the risk that the radial force exerted by the stent itself might rupture the aneurysm.

The advantages described above with respect to the embodiment shown in Fig. 3 may also be enjoyed in other locations. Referring now to Fig. 4, there is shown another embodiment of the present invention comprising iliac leg portions 60 and 61 of an endograft 62, each having proximal bulbous portions 64 and a plurality of affixation members 66. Bulbous portions 64 are adapted for deployment in shoulder regions 67 located distally of iliac necks 68 of iliac arteries 70 and 71 at the proximal end of an aneurysm. Like the embodiment shown in Fig. 3, the use of such an embodiment may prevent or delay continued diametric expansion of shoulder region 67, thereby inhibiting progression of aneurysmal disease, and may also inhibit endoleak formation by providing improved migration resistance and better sealing as compared to endografts lacking the bulbous portion.

Leg portions 60 and 61 may be part of a modular or non-modular AAA prosthesis comprising a distal bulbous portion 41 as depicted in Fig. 3, or may be part of a modular or non-modular AAA prosthesis comprising a standard, non-bulbous trunk portion known in the art. The connections between leg portions 60 and 61 and prosthesis 30 may comprise any connection for modular or non-modular prostheses

known in the art, including embodiments in which distal bulbous portion 41 and one of proximal bulbous portions leg portions 60 and 61 are part of a single modular component, and the other leg comprises a mating modular component. Embodiments in which both leg portions are modular components or both legs are integral components may also be provided. Leg portions 60 and 61 may be deployed by any method known in the art.

Although depicted as two leg members 60 and 61 for deployment in iliac arteries 70 and 71, respectively, it should be understood that a prosthesis may comprise more than two dependent members of any type, and that such a prosthesis having dependent members may be adapted for deployment in any type of body lumen. Furthermore, although both leg members are shown with bulbous portions in Fig. 4, embodiments may also be provided in which less than all of the multiple dependent members have bulbous portions.

Thus, the endograft embodiments of the present invention may be used for performing a method of repairing a body lumen, as depicted in the flowchart shown in Fig. 5. The method first comprises step 100 of providing an endograft having an expanded configuration as shown in Fig. 3 and a compressed configuration (not shown), similar to the compressed configuration known in the art for any endoluminal device. In the expanded configuration, the endograft has a neck 40 with diameter d_1 approximately equal to the lumen neck region width w_1 and a bulbous portion 41 having at least a distal, shoulder portion 46 adapted to match the diverging width of lumen shoulder region 38. Endograft 30 comprises a plurality of affixation members 42 for affixing to lumen wall 32, the affixation members disposed along an axial portion 44 of endograft 30 including at least neck 40 and distal portion 46 of bulbous portion 41. The method then comprises step 110 of constraining the endograft in its compressed configuration for introduction into the body lumen. Next, in step 120, the compressed and constrained endograft 30 is advanced to a deployment location aligned with the lumen neck region and lumen shoulder region, such as the region shown in Fig. 3. Finally, in step 130, endograft 30 is deployed so that one or more of affixation members 42 in endograft neck 40 affix to lumen neck region 36 and one or more of the affixation members in bulbous portion 41 affix to at least a portion of lumen shoulder region 38. As shown in Fig. 3, where stent 50 is a self-expanding stent, the stent in the area of neck 40 exerts a radial expansion force that is greater than the radial expansion force exerted in the area of bulbous portion 41.

For a modular endograft with multiple bulbous regions, such as an endograft comprising bulbous portion 41 at its distal end, as shown in Fig. 3, and iliac

- 10 -

leg portions 60 and 61 at its proximal end, as shown in Fig. 4, it may be desirable to first deploy bulbous portion 41 as described above, and then reverse-deploy the leg portions to assure desired placement of the bulbous portions 64. Exemplary reverse deployment methods are described generally in U.S. Application Serial No. 10/080,791, filed February 22, 2002, by Haverkost et al., titled METHOD AND SYSTEM FOR DEPLOYING MULTI-PART ENDOLUMINAL DEVICES, incorporated herein by reference.

The devices as well as any graft linings or coatings used with the devices of the present invention may comprise any suitable materials of construction known in the art, including any type of surface modification known in the art. For example, it may be desirable to provide the device with a coating of a biologically or pharmacologically active substance for enhancing the effectiveness of the device generally, or of the shoulder or bulbous portion specifically. The term "biologically or pharmacologically active substance" refers to any substance, whether synthetic or natural, that has a pharmacological, chemical, or biological effect on the body or a portion thereof. Suitable biologically or pharmacologically active materials that can be used in this invention include without limitation glucocorticoids (e.g. dexamethasone, betamethasone), antithrombotic agents such as heparin, cell growth inhibitors, hirudin, angiopeptin, aspirin, growth factors such as VEGF, antisense agents, anti-cancer agents, anti-proliferative agents, oligonucleotides, antibiotics, and, more generally, antiplatelet agents, anti-coagulant agents, antimitotic agents, antioxidants, antimetabolite agents, and anti-inflammatory agents may be used. Antiplatelet agents can include drugs such as aspirin and dipyridamole. Aspirin is classified as an analgesic, antipyretic, anti-inflammatory and antiplatelet drug. Dipyridamole is a drug similar to aspirin in that it has anti-platelet characteristics. Dipyridamole is also classified as a coronary vasodilator. Anticoagulant agents may include drugs such as heparin, protamine, hirudin and tick anticoagulant protein. Anti-cancer agents may include drugs such as taxol and its analogs or derivatives. Taxol is also classified as a cell-growth inhibitor. Antioxidant agents may include probucol. Anti-proliferative agents may include drugs such as amlodipine and doxazosin. Antimitotic agents and antimetabolite agents may include drugs such as methotrexate, azathioprine, vincristine, vinblastine, 5-fluorouracil, adriamycin and mutamycin. Antibiotic agents can include penicillin, cefoxitin, oxacillin, tobramycin, and gentamicin. Suitable antioxidants include probucol. Also, genes or nucleic acids, or portions thereof may be used. Such genes or nucleic acids can first be packaged in liposomes or nanoparticles. Furthermore, collagen-synthesis inhibitors, such as tranilast, may be used.

- 11 -

Additional biologically or pharmacologically active substances and carriers for these substances are listed in U.S. Patents No. 6,364,856; No. 6,358,556; and No. 6,258,121; all of which are incorporated herein by reference. In addition to disclosing additional active substances, these patent references disclose polymer materials impregnated with active substances for use as coatings on the outside of medical devices to provide controlled delivery of the active substances. Devices of the present invention may also comprise such impregnated polymer materials.

Although the aorta illustrated in Fig. 3 has a generally regular shape, aneurysms with irregular shapes are not uncommon. Therefore, it may be additionally desirable to provide the device with one or more portions, particularly the shoulder or bulbous portion, with the ability to conform to an irregular shape. This may be accomplished using a balloon-expandable stent framework having plastically-deformable materials of construction, such as but not limited to gold, platinum, tantalum, titanium, stainless steel, tungsten, a cobalt alloy, a nickel or titanium alloy, such as a plastically deformable grade of nitinol or deformable core nitinol composite, or a combination of any of the above. A combination self-expanding, balloon-expandable stent framework may also be used, comprising a combination of superelastic and plastically deformable materials, such as is described, for example, in U.S. Patent Application Serial No. 09/702,226, to Steven E. Walak, titled COMBINATION SELF-EXPANDABLE, BALLOON-EXPANDABLE ENDOLUMINAL DEVICE, filed October 31, 2000, and incorporated herein by reference. Methods of using such devices include deploying the device initially by self-expansion, followed by modeling the plastically deformable sections to conform to the lumen geometry using an inflatable balloon or other modeling device

Although the bulbous portions disclosed in the present invention are shown at or near the ends of the devices, it should be understood that a bulbous portion may be provided at any location on a device. Furthermore, although a bulbous configuration has been generally described herein, it should be understood that the important characteristic of the device is that the shoulder portion have a diameter profile that conforms to the contour of the shoulder region of the lumen. By "diameter profile that conforms to the contour" it is meant that if the lumen shoulder region diameter diverges from a neck region having a first diameter to a relatively wider second diameter along a given length with a given slope, the shoulder portion of the device similarly diverges from approximately the first diameter to approximately the second diameter along approximately the same given length with approximately the same given slope. Thus, if lines plotting the diameter versus length were graphed for

- 12 -

the shoulder region of the device and the shoulder region of the lumen, the line corresponding to the shoulder portion of the device would have a similar slope the line for the shoulder region of the lumen. While it is important that shoulder portion 46 of device 30 shown in Fig. 3 has a configuration that conforms to shoulder region 38 of the lumen, the device proximal of shoulder portion may have any configuration, such as a configuration with a tapering diameter or even a step-change back to diameter d_1 rather than the bulbous configuration shown.

Finally, providing a bulbous portion or other defined shoulder portion having a diameter profile that conforms to the contour of the shoulder region of the lumen in which the device is implanted is advantageous both by itself and in conjunction with providing affixation members in the bulbous or shoulder portion. Although the figures shown herein depict bulbous or shoulder portions with affixation members, it should be recognized that devices having such portions without affixation members may also be provided.

Although illustrated and described herein with reference to certain specific embodiments, the present invention is nevertheless not intended to be limited to the details shown. Rather, various modifications may be made in the details within the scope and range of equivalents of the claims and without departing from the spirit of the invention. In particular, for example, although some embodiments have been described herein having elements labeled with "distal" or "proximal" directional descriptors, it should be understood that one equivalent embodiment may comprise the same elements with the directional descriptors reversed.

What is claimed is:

1 1. An endoluminal device for affixation to a wall of a body lumen, the
2 body lumen having a neck region defined by a relatively narrow width and a shoulder
3 region that diverges from the neck region to a relatively wider width, the device
4 comprising a shoulder portion having a device diameter profile that conforms to a
5 lumen diameter profile of the shoulder region for deployment in the shoulder region.

1 2. The device of claim 1, wherein the shoulder portion comprises
2 part of a bulbous portion.

1 3. The endoluminal device of claim 2, wherein the device comprises
2 a device neck located adjacent the bulbous portion, the device neck having a first
3 diameter, and the bulbous portion having a length characterized by a diverging and
4 converging diameter greater than the first diameter along the bulbous portion length.

1 4. The endoluminal device of claim 3, wherein the device comprises
2 a compressed configuration and a radially expanded configuration, the device neck
3 having a first radial self-expansion force and the shoulder portion having a second
4 radial self-expansion force less than the first radial expansion force.

1 5. The device of claim 2, wherein the bulbous portion of the device
2 comprises a stent having at least one superelastic section and at least one plastically
3 deformable section.

1 6. The device of claim 1 further comprising a plurality of affixation
2 members at least on part of the shoulder portion.

1 7. The endoluminal device of claim 6, wherein the affixation
2 members comprise hooks, barbs, or other members that project radially outward from
3 the device.

1 8. The endoluminal device of claim 6, wherein the device has a distal
2 end adapted to be positioned in an upstream portion of the lumen and the plurality of
3 affixation members are disposed in an area of the device extending proximally from the
4 distal end of the device through the shoulder portion.

1 9. The endograft of claim 8, wherein the area in which the plurality
2 of affixation members are disposed extends axially to a maximum diameter portion of
3 the shoulder portion.

1 10. The endoluminal device of claim 1, wherein the device comprises
2 a stent.

3 11. The device of claim 10, wherein the stent comprises at least one
4 superelastic section and at least one plastically deformable section.

1 12. The device of claim 1, wherein the shoulder portion of the device
2 comprises a stent having at least one superelastic section and at least one plastically
3 deformable section.

1 13. The endoluminal device of claim 1, wherein the device comprises
2 an endograft comprising a stent that is at least partially covered or lined with a graft
3 material.

1 14. The endoluminal device of claim 13, wherein the endograft is
2 adapted to repair an aneurysm.

1 15. The endoluminal device of claim 14, wherein the endograft is
2 adapted to repair an abdominal aortic aneurysm (AAA).

1 16. The endoluminal device of claim 15, wherein the neck region
2 includes a renal neck at a distal end of the aneurysm and the shoulder portion is
3 positioned proximal the renal neck at the shoulder region.

1 17. The endoluminal device of claim 15, wherein the neck region
2 includes an iliac neck at a proximal end of the aneurysm and the shoulder portion is
3 positioned distally of the iliac neck.

1 18. An endoluminal device adapted to repair an abdominal aortic
2 aneurysm (AAA) for affixation to a wall of a body lumen, the body lumen having a renal
3 neck region, defined by a relatively narrow width, and a renal shoulder region that
4 diverges from the renal neck region at a distal end of the aneurysm and an iliac neck
5 region, defined by a relatively narrow width, and an iliac shoulder region that diverges
6 from the iliac neck region at a proximal end of the aneurysm, the device comprising a
7 distal shoulder portion having a diameter profile that conforms to the renal shoulder
8 region for deployment in the renal shoulder region; and one or more proximal shoulder
9 portions each for deployment in the iliac shoulder region, each proximal shoulder
10 portion having a diameter profile that conforms to the corresponding iliac shoulder
11 region.

1 19. The device of claim 18 further comprising a plurality of affixation
2 members at least on part of the distal shoulder portion and on part of the one or more
3 proximal shoulder portions.

1 20. The device of claim 19 wherein the distal shoulder portion is part
2 of a distal bulbous portion and each of the one or more proximal shoulder portions are
3 part of a corresponding proximal bulbous portion.

1 21. The endoluminal device of claim 18, wherein the distal shoulder
2 portion and the one or more proximal shoulder portions comprise a non-modular
3 device.

1 22. The endoluminal device of claim 18, wherein the distal shoulder
2 portion and the one or more proximal shoulder portions comprise a modular device.

1 23. The endoluminal device of claim 22, wherein a first modular
2 component comprises the distal shoulder portion and a first proximal shoulder portion,
3 and a second modular component comprises a second proximal shoulder portion.

1 24. An endograft for repair of an abdominal aortic aneurysm (AAA)
2 having a lumen wall, the endograft comprising a stent at least partially lined or covered
3 by a graft material and having a distal end comprising a distal neck having a first
4 diameter and a first bulbous portion located proximally of the distal neck and having a
5 proximally diverging then converging diameter greater than the first diameter, at least
6 the distal neck and part of the first bulbous portion comprising a plurality of affixation
7 members that project radially outward from the device for affixation to the lumen wall
8 of the AAA.

9 25. The endograft of claim 24, wherein the plurality of affixation
10 members are disposed in an area that extends axially from a distal end of the
11 endograft to at least an intermediate location in the first bulbous portion.

1 26. The endograft of claim 25, wherein the area in which the plurality
2 of affixation members are disposed extends axially to a maximum diameter portion of
3 the first bulbous portion.

1 27. The endograft of claim 24 having a compressed configuration and
2 a radially expanded configuration, the device neck having a first radial self-expansion
3 force and the first bulbous portion having a second radial self-expansion force less than
4 the first radial self-expansion force.

1 28. The endograft of claim 24 further comprising a proximal end
2 comprising at least one proximal neck having a second diameter and an additional
3 corresponding bulbous portion located distally of the proximal neck and having a
4 distally diverging then converging diameter greater than the second diameter, at least
5 the proximal neck and part of the additional corresponding bulbous portion comprising

6 a plurality of affixation members that project radially outward from the device for
7 affixation to the lumen wall of the AAA.

1 29. The endograft of claim 28 comprising two proximal necks and two
2 additional corresponding bulbous portions; each proximal neck and additional
3 corresponding bulbous portion for deployment adjacent an iliac neck region of the AAA.

1 30. The endograft of claim 28, wherein the distal neck and first
2 bulbous portion comprise a first modular component and the proximal neck and
3 additional corresponding bulbous portion comprises a second modular component.

1 31. The endograft of claim 29, wherein the distal neck and first
2 bulbous portion comprise a first modular component, and each proximal neck and
3 additional corresponding bulbous portion comprise additional modular components.

1 32. The endograft of claim 29, wherein the distal neck, first bulbous
2 portion, one proximal neck, and one additional corresponding bulbous portion comprise
3 a first modular component, and another proximal neck and additional corresponding
4 bulbous portion comprise a second modular component.

1 33. A method of inhibiting diametric expansion of an aneurysm having
2 a lumen wall, the aneurysm having an aneurysm neck region at one end having a width
3 and a shoulder region adjacent the neck region having a diverging width greater than
4 the width of the aneurysm neck region, the method comprising deploying an endograft
5 in the aneurysm, the endograft having an endograft neck with a diameter
6 approximately equal to the width of the aneurysm neck region and a shoulder portion
7 having a device diameter profile that conforms to a lumen diameter profile of the
8 shoulder region of the aneurysm, the endograft neck and the shoulder portion
9 comprising a plurality of affixation members for affixing to the lumen wall of the
10 aneurysm.

1 34. A method of inhibiting endoleak formation and migration of an
2 endograft deployed in a lumen having a lumen wall, a lumen neck region having a
3 lumen neck width, and a lumen shoulder region adjacent the lumen neck region having
4 a diverging width greater than the lumen neck region width, the method comprising:
5 providing the endograft with an endograft neck having a diameter
6 approximately equal to the lumen neck region diameter and a shoulder portion adapted
7 to match the diverging width of the lumen shoulder region.

1 35. The method of claim 34 further comprising providing the
2 endograft neck and the shoulder portion with a plurality of affixation members for
3 affixing to the lumen wall.

1 36. The method of claim 34 further comprising providing the shoulder
2 portion as part of a bulbous portion.

1 37. The method of claim 35 further comprising providing the shoulder
2 portion as part of a bulbous portion.

1 38. A method of repairing a body lumen having a lumen wall, a lumen
2 neck region having a lumen neck width, and a lumen shoulder region proximal the
3 lumen neck region having a diverging width greater than the lumen neck region width,
4 the method comprising the steps of:

5 (a) providing an endograft having an expanded configuration and a
6 compressed configuration, the endograft comprising in the expanded configuration an
7 endograft neck with a diameter approximately equal to the lumen neck region width
8 and a bulbous portion having a shoulder portion adapted to match the diverging width
9 of the lumen shoulder region; and the endograft comprising a plurality of affixation
10 members for affixing to the lumen wall, the affixation members disposed along an axial
11 region of the endograft including at least the endograft neck and the shoulder portion
12 of the bulbous portion;

13 (b) constraining the endograft in the compressed configuration for
14 introduction into the body lumen;

15 (c) advancing the endograft to a deployment location; and

16 (d) deploying the endograft so that the endograft shoulder portion is
17 aligned with the lumen shoulder region and one or more of the affixation members in
18 the endograft neck affix to the lumen neck region and one or more of the affixation
19 members in the endograft shoulder portion affix to at least a portion of the lumen
20 shoulder region.

1 39. The method of claim 38, wherein the method comprises repairing
2 an aneurysm.

1 40. The method of claim 38, wherein the method comprises repairing
2 an abdominal aortic aneurysm.

1 41. The method of claim 39, wherein the endograft comprises a self-
2 expanding stent having at least a partial covering or lining of a graft material, the step

3 of deploying the endograft comprising releasing the endograft from a radial constraint
4 that confines it in the compressed configuration so that the self-expanding stent self-
5 expands from the compressed configuration to the expanded configuration.

1 42. The method of claim 41, wherein, after deploying the stent, the
2 stent exerts a radial expansion force against the lumen wall, wherein the radial
3 expansion force exerted by the endograft neck is greater than the radial expansion
4 force exerted by the bulbous portion.

1 43. The method of claim 41, wherein the endograft comprises a
2 combination self-expanding/plastically-deformable stent and the step of deploying the
3 endograft further comprising, after the self-expansion of the stent, modeling the stent
4 the conform the stent to the lumen wall.

1 44. A method of repairing an abdominal aortic aneurysm (AAA) in a
2 body lumen having a lumen wall, the body lumen having, at a distal end of the AAA, a
3 renal neck region, defined by a relatively narrow width, and a renal shoulder region
4 that diverges from the renal neck region; and, at a proximal end of the AAA, one or
5 more iliac neck regions defined by a relatively narrow width, and one or more iliac
6 shoulder regions, each of which diverges from the corresponding iliac neck region, the
7 method comprising the steps of:

8 (a) providing an endograft having an expanded configuration and a
9 compressed configuration, the endograft comprising a modular device having a first
10 modular component comprising a distal bulbous region and one or more additional
11 modular components each comprising a proximal bulbous region, wherein, in the
12 expanded configuration, the endograft comprises (i) a first endograft neck with a
13 diameter approximately equal to the renal neck region width with the distal bulbous
14 portion having at least a shoulder portion adapted to match the diverging width of the
15 renal shoulder region and (ii) an additional endograft neck with a diameter
16 approximately equal to the iliac neck region width with the proximal bulbous portion
17 having at least a shoulder portion adapted to match the diverging width of the iliac
18 shoulder region; and the endograft comprises a plurality of affixation members for
19 affixing to the lumen wall, the affixation members disposed along an axial region of the
20 endograft including at least the first and additional endograft necks and the shoulder
21 portion of the distal bulbous portion and the shoulder portion of the proximal bulbous
22 portion;

23 (b) constraining the endograft in the compressed configuration for
24 introduction into the body lumen;

- 19 -

25 (c) advancing the endograft to a deployment location;

26 (d) deploying the first modular component of the endograft so that
27 the shoulder portion of the distal bulbous portion is aligned with the renal shoulder
28 region and one or more of the affixation members in the first endograft neck affix to
29 the renal neck region and one or more of the affixation members in the distal bulbous
30 portion affix to at least a portion of the renal shoulder region; and

31 (e) then deploying the one or more additional modular components of
32 the endograft so that the shoulder portion of each proximal bulbous portion is aligned
33 with a corresponding iliac shoulder region and one or more of the affixation members in
34 each additional endograft neck affix to the corresponding iliac neck region and one or
35 more of the affixation members in each proximal bulbous portion affix to at least a
36 portion of the corresponding iliac shoulder region, each of the one or more additional
37 modular components mating with the first modular component such that a distal end of
38 each additional modular component connects to a proximal end of the first modular
39 component.

1 45. The method of claim 44, comprising reverse-deploying the one or
2 more additional modular components.

1 / 3

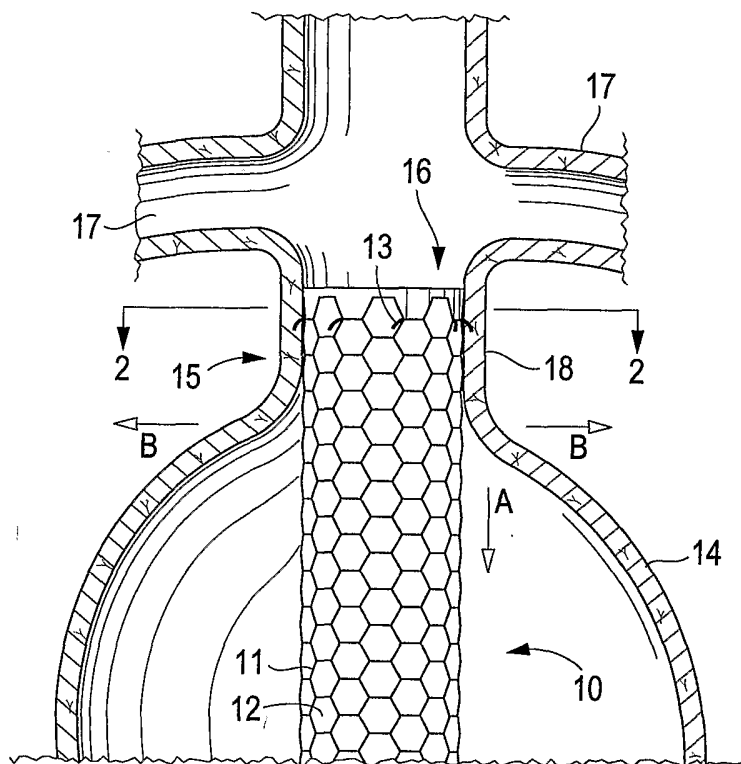

FIG. 1
PRIOR ART

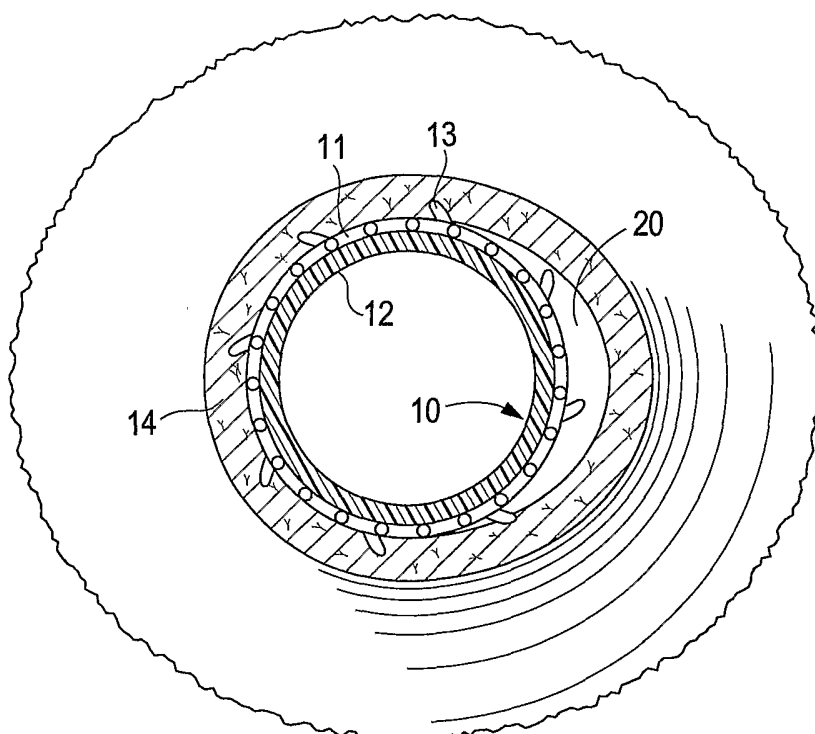

FIG. 2
PRIOR ART

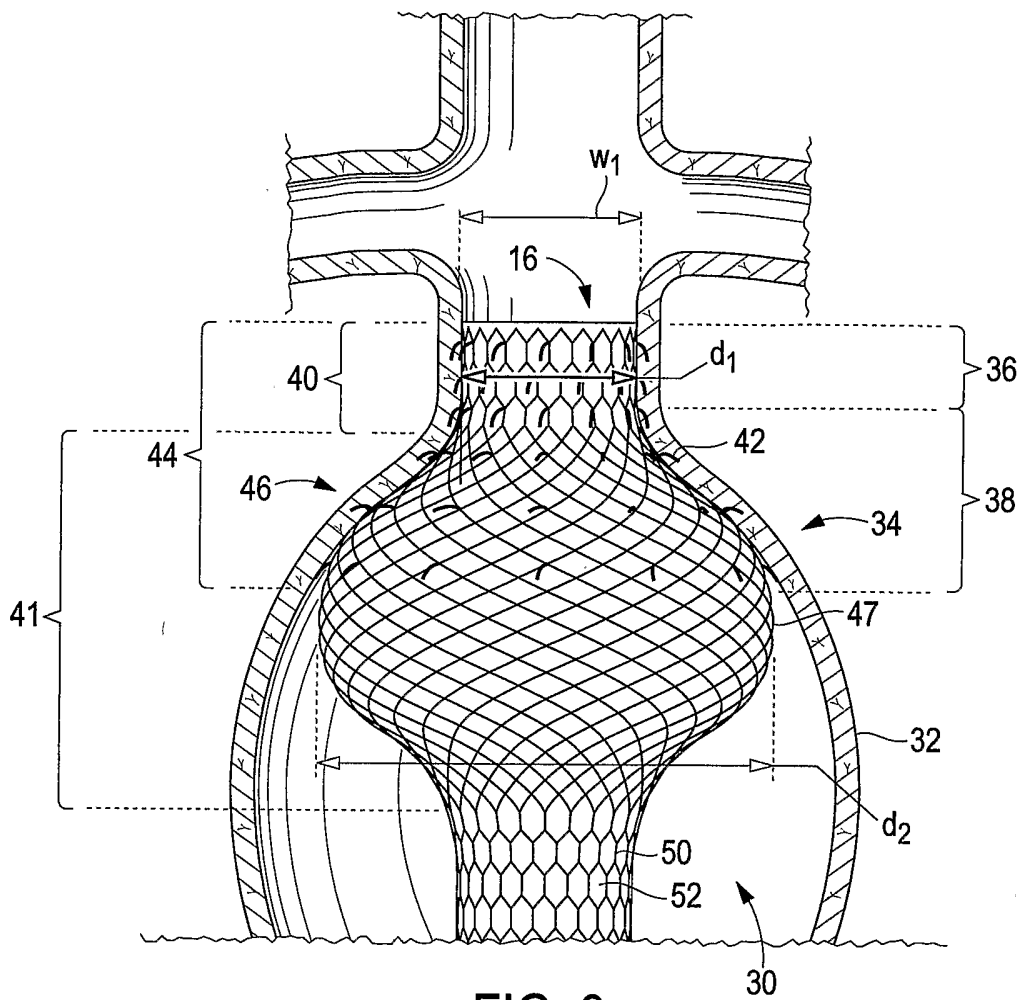

FIG. 3

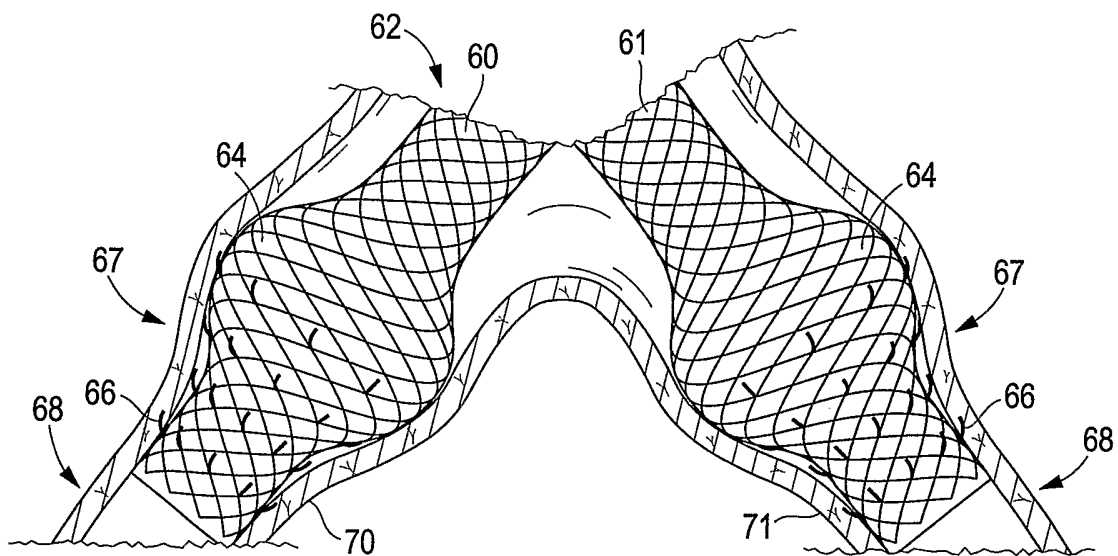

FIG. 4

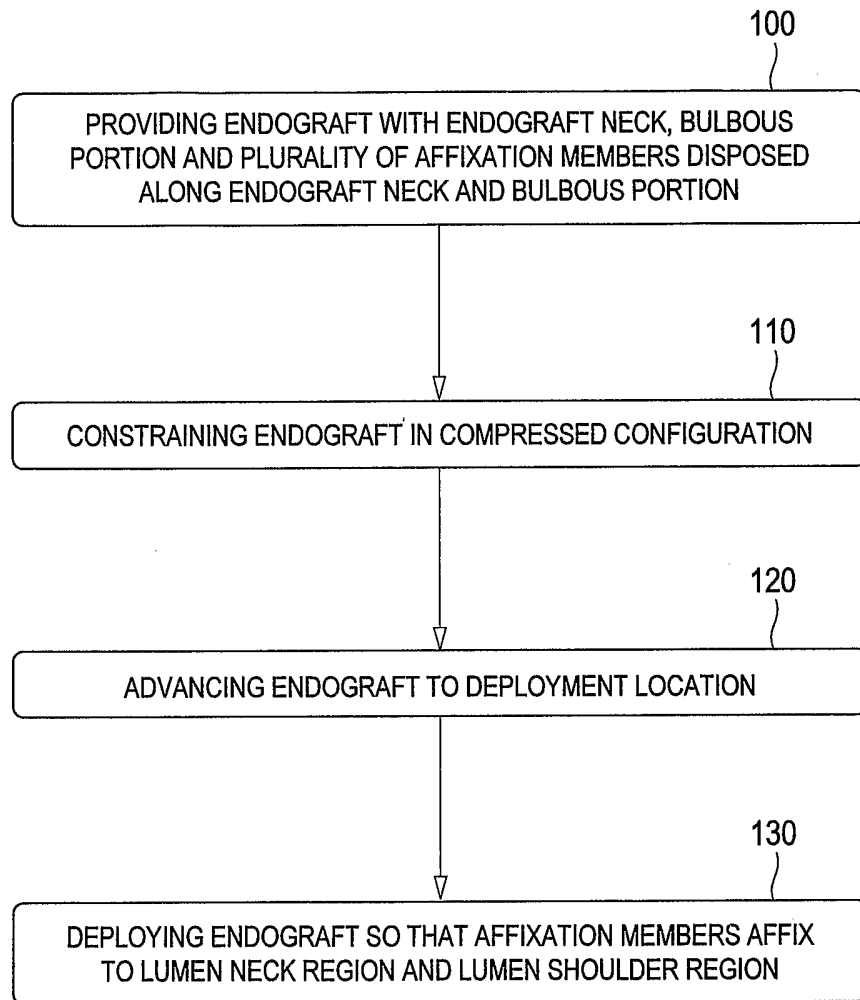

FIG. 5

INTERNATIONAL SEARCH REPORT

International Application No
PCT/US2004/003812

A. CLASSIFICATION OF SUBJECT MATTER
IPC 7 A61F2/06 A61F2/01

According to International Patent Classification (IPC) or to both national classification and IPC

B. FIELDS SEARCHED

Minimum documentation searched (classification system followed by classification symbols)
IPC 7 A61F

Documentation searched other than minimum documentation to the extent that such documents are included in the fields searched

Electronic data base consulted during the international search (name of data base and, where practical, search terms used)
EPO-Internal

C. DOCUMENTS CONSIDERED TO BE RELEVANT

Category °	Citation of document, with indication, where appropriate, of the relevant passages	Relevant to claim No.
X	WO 02/36045 A (SCIMED LIFE SYSTEMS INC) 10 May 2002 (2002-05-10) page 17, line 20 - line 32; figure 9 -----	1, 2, 5, 10-12, 14-17, 22, 23, 30-32, 36, 37
X	WO 01/72239 A (SHALEV ILAN ;DARVISH NISSIM (IL); TSEHORI JONATHAN (IL); NEOVASC I) 4 October 2001 (2001-10-04) page 15, line 8 - line 10; figures 9A,9B -----	1-3, 6, 7, 18, 20, 21, 24, 34-37
X	US 6 162 244 A (KLEPETKO WALTER ET AL) 19 December 2000 (2000-12-19) column 1, line 31 - line 38; figure 8 -----	1, 13, 18, 24, 34

Further documents are listed in the continuation of box C.

Patent family members are listed in annex.

° Special categories of cited documents :

- *A* document defining the general state of the art which is not considered to be of particular relevance
- *E* earlier document but published on or after the international filing date
- *L* document which may throw doubts on priority claim(s) or which is cited to establish the publication date of another citation or other special reason (as specified)
- *O* document referring to an oral disclosure, use, exhibition or other means
- *P* document published prior to the international filing date but later than the priority date claimed

- *T* later document published after the international filing date or priority date and not in conflict with the application but cited to understand the principle or theory underlying the invention
- *X* document of particular relevance; the claimed invention cannot be considered novel or cannot be considered to involve an inventive step when the document is taken alone
- *Y* document of particular relevance; the claimed invention cannot be considered to involve an inventive step when the document is combined with one or more other such documents, such combination being obvious to a person skilled in the art.
- *&* document member of the same patent family

Date of the actual completion of the international search

15 June 2004

Date of mailing of the international search report

22/06/2004

Name and mailing address of the ISA

European Patent Office, P.B. 5818 Patentlaan 2
 NL - 2280 HV Rijswijk
 Tel. (+31-70) 340-2040, Tx. 31 651 epo nl,
 Fax: (+31-70) 340-3016

Authorized officer

Newman, B

INTERNATIONAL SEARCH REPORT

Information on patent family members

International Application No
PCT/US2004/003812

Patent document cited in search report	A	Publication date		Patent family member(s)	Publication date
WO 0236045	A	10-05-2002		AU 9473801 A	15-05-2002
				EP 1337198 A2	27-08-2003
				WO 0236045 A2	10-05-2002
WO 0172239	A	04-10-2001		AU 4678101 A	08-10-2001
				CA 2404330 A1	04-10-2001
				CN 1430490 T	16-07-2003
				EP 1276437 A2	22-01-2003
				WO 0172239 A2	04-10-2001
				JP 2003527924 T	24-09-2003
				US 2003097172 A1	22-05-2003
US 6162244	A	19-12-2000		DE 19707642 A1	02-10-1997
				AT 202915 T	15-07-2001
				WO 9736556 A1	09-10-1997
				DE 59704024 D1	16-08-2001
				EP 0901353 A1	17-03-1999
				ES 2159862 T3	16-10-2001
				JP 2001502192 T	20-02-2001

INTERNATIONAL SEARCH REPORT

International application No.
PCT/US2004/003812

Box II Observations where certain claims were found unsearchable (Continuation of item 2 of first sheet)

This International Search Report has not been established in respect of certain claims under Article 17(2)(a) for the following reasons:

1. Claims Nos.: 33, 38 - 45
because they relate to subject matter not required to be searched by this Authority, namely:
Rule 39.1(iv) PCT - Method for treatment of the human or animal body by surgery
2. Claims Nos.:
because they relate to parts of the International Application that do not comply with the prescribed requirements to such an extent that no meaningful International Search can be carried out, specifically:
3. Claims Nos.:
because they are dependent claims and are not drafted in accordance with the second and third sentences of Rule 6.4(a).

Box III Observations where unity of invention is lacking (Continuation of item 3 of first sheet)

This International Searching Authority found multiple inventions in this international application, as follows:

1. As all required additional search fees were timely paid by the applicant, this International Search Report covers all searchable claims.
2. As all searchable claims could be searched without effort justifying an additional fee, this Authority did not invite payment of any additional fee.
3. As only some of the required additional search fees were timely paid by the applicant, this International Search Report covers only those claims for which fees were paid, specifically claims Nos.:
4. No required additional search fees were timely paid by the applicant. Consequently, this International Search Report is restricted to the invention first mentioned in the claims; it is covered by claims Nos.:

Remark on Protest

- The additional search fees were accompanied by the applicant's protest.
- No protest accompanied the payment of additional search fees.