

Jan. 8, 1935.

L. J. VETRANO

1,987,353

WRENCH

Filed Feb. 28, 1933

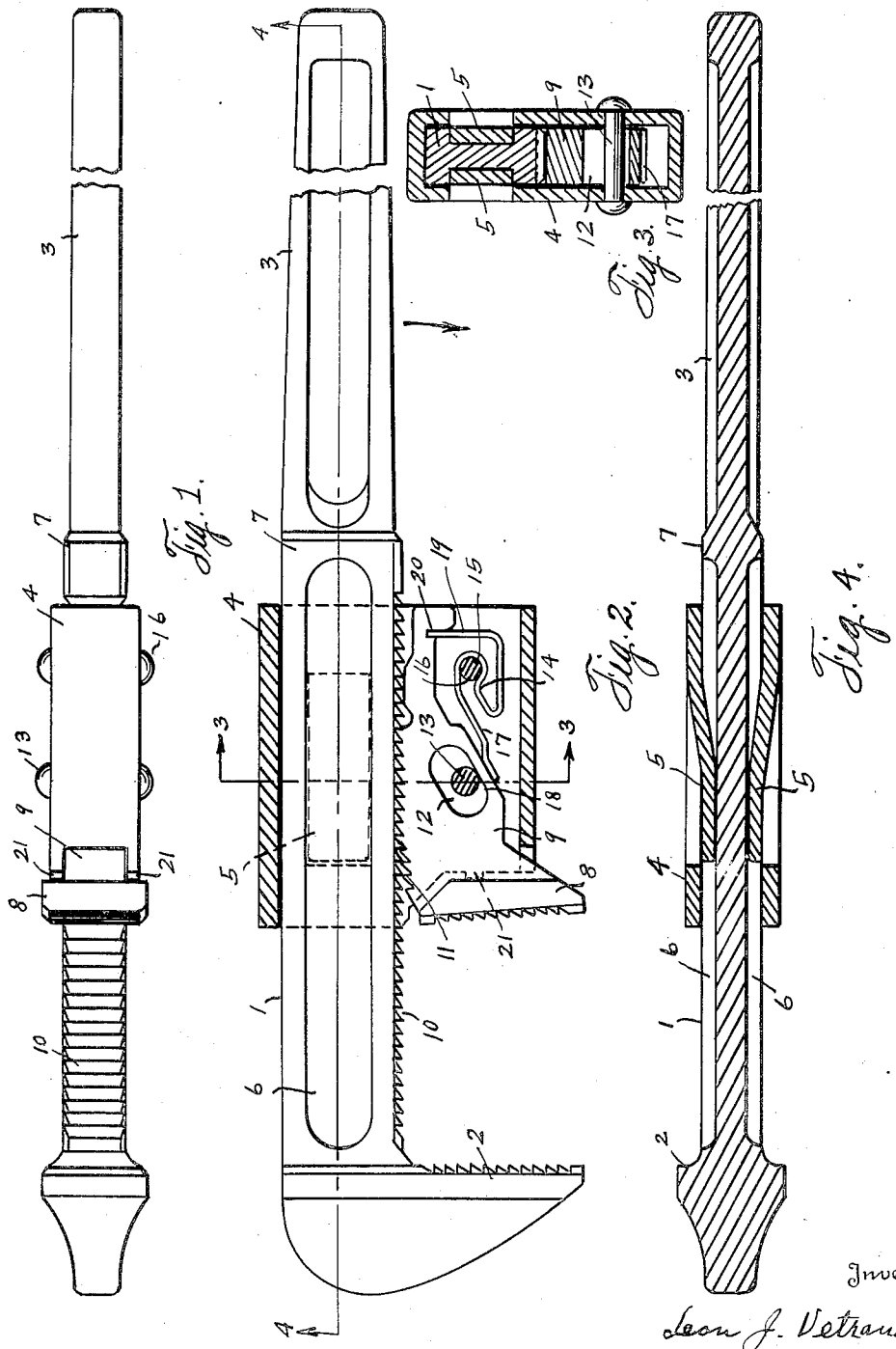

Fig. 1.

Fig. 2.

Fig. 3.

Fig. 4.

Inventor

Leon J. Vetrano

Hardway Kather

Attorneys

324

UNITED STATES PATENT OFFICE

1,987,353

WRENCH

Leon J. Vetrano, Houston, Tex.

Application February 28, 1933, Serial No. 658,953

3 Claims. (Cl. 81—154)

This invention relates to a wrench.

An object of the invention is to provide a wrench of the character described having a handle provided with a fixed jaw and a movable jaw arranged to co-act with the fixed jaw to grip either round, polygonal or irregular objects, said movable jaw being mounted in such novel manner that it will be securely maintained in gripping position, or may be adjusted to objects of different sizes, or to released position.

Another object is to provide a wrench of the character described having an adjustable frame on the handle with a jaw mounted therein, said jaw and the handle having interengaging means with novel means for normally holding said interengaging means in interengaged relation.

Another object is to provide novel means for maintaining the frame against detachment from the handle.

With the above and other objects in view this invention relates to certain novel features of construction, operation and arrangement of parts, an example of which is given in this specification and illustrated in the accompanying drawing, wherein:—

Figure 1 shows a front view of the wrench.

Figure 2 shows a side view, partly in section.

Figure 3 shows a cross sectional view, taken on the line 3—3 of Figure 2, and

Figure 4 shows a longitudinal sectional view taken on the line 4—4 of Figure 2.

Referring now more particularly to the drawing, wherein like numerals of reference designate similar parts in each of the figures, the numeral 1 designates the handle of the wrench whose operative end is formed with a fixed jaw 2 and whose other end forms the grip 3.

Slidably mounted on the handle there is the frame 4, sleeve-like in form, and approximately rectangular in cross sectional contour. This frame has the side gripping fingers 5, 5 integral therewith and having their free ends offset inwardly to grip the handle and run in the side grooves 6, 6 thereof.

The movement of the frame along the handle is limited by the engagement of said fingers with the jaw 2 on one side and the stop 7 on the other.

Confronting the fixed jaw and mounted in said frame there is a movable jaw 8 which has a flat shank 9 which is extended into said frame. The adjacent margins of the handle 1 and shank 9 have the intermeshing ratchet teeth 10, 11, respectively, the latter of which are arcuately arranged. The shank 9 has an approximately elliptical slot 12, whose major axis diverges for-

wardly relative to the longitudinal axis of the handle and there is a bearing pin 13 extending through said slot and whose ends are anchored to the sides of the frame. There is a flat spring 14 within the frame 4 and which is shaped with a grip 15 which is gripped around the cross pin 16 whose ends are anchored to the sides of said frame. One end 17, of this spring bears against the outer margin of the shank 9 and normally tends to hold the teeth 10, 11 in engagement with the outer sloping side 18, of the slot 12, bearing against the pin 16. The other end 19, of this spring is inwardly turned and engaged in a notch 20 at the outer end of said shank 9 and the spring is under tension so that the resistance of the two ends of the spring against said shank will tend to force the shank inwardly, relative to the frame, to maintain the teeth 10, 11, in engagement.

The jaw 8 is extended laterally, on each side beyond the frame 4 and is of approximately the same width as that of the jaw 2 and the confronting faces of said jaws are toothed.

The forward end of the frame 4 has the projections 21, 21 extending forwardly to abut the jaw 8 to minimize the friction between the frame and the jaw 8 to conduce to the free movement of the latter.

When the wrench is applied to an object to be turned and the handle then manipulated in a direction indicated by the arrow in Figure 2 the jaws 2 and 8 will grip said object and as the power is increased, the jaw 8 will move inwardly relative to the handle and the coacting teeth 11, 10, will successively come into engagement forwardly, and the teeth 10 and 11 are so pitched that said movable jaw 8 will be securely held against slippage relative to the handle.

When it is desired to adjust the movable jaw the handle may be held and the frame 4 grasped and pulled outwardly toward the grip 3 and as the pin 13 rides upon the face 18 the shank 9 and jaw 8 will be moved outwardly or away from the handle and the teeth 11 will be disengaged from the teeth 10 to permit such adjustment; or the wrench may be held vertically, with its grip end downwardly, and tapped on a stationary object with a like result.

The frame may be mounted on the handle by inserting the grip end of the handle through the frame and forcing the free ends of the fingers 5, 5 apart and moving the frame along the handle until said fingers snap into the grooves 6, 6, and said fingers will hold the frame in place during the ordinary use of the wrench.

The drawing and description disclose what is now considered to be a preferred form of the invention by way of illustration only while the broad principle of the invention will be defined by the appended claims.

5 What I claim is:

1. A wrench comprising a handle having a fixed gripping jaw, a frame slidable on the handle, a movable gripping jaw confronting the fixed jaw and having an extended shank in the frame, said movable jaw and shank being movable relative to the frame, interengaging teeth on said handle and shank, a spring anchored to and housed within the frame and whose ends are free and operate against the shank to normally maintain said teeth engaged, said shank and frame having cooperating parts effective to cause the disengagement of said teeth upon movement of the frame along the handle from the fixed jaw.

20 2. A wrench comprising a handle having a fixed gripping jaw, a frame slidable on the handle, a movable gripping jaw confronting the fixed jaw and having a shank extended into the frame and whose outer end is provided with a notch, said movable jaw and shank being movable relative to the frame, interengaging teeth on the handle

and shank, a cross pin in the frame, a flat spring within the frame, shaped with a grip which engages around said cross pin, one end of said spring bearing against the shank and the other end of the spring engaging in said notch, said spring being maintained under tension and acting on said shank to normally maintain said teeth interengaging.

3. A wrench comprising a handle having a fixed gripping jaw, a frame slidable on the handle, a movable gripping jaw confronting the fixed jaw and having a shank extended into the frame, interengaging teeth on said handle and shank, said shank having a bearing face which diverges, relative to the longitudinal axis of the handle, toward the fixed jaw, a bearing pin anchored to the frame and bearing against said face, a flexible spring anchored to the frame and having one end connected to said shank and normally under tension and tending to move said face outwardly toward the grip end of the handle and the other end of the spring bearing against the shank and tending to force the shank inwardly to maintain the teeth interengaged.

LEON J. VETRANO.

5

10

15

20

25