

(19) **DANMARK**

(10) **DK/EP 2990653 T3**



Patent- og
Varemærkestyrelsen

(12) **Oversættelse af
europæisk patentskrift**

-
- (51) Int.Cl.: **F 04 D 15/02 (2006.01)** **F 16 K 17/08 (2006.01)** **F 16 K 17/30 (2006.01)**
- (45) Oversættelsen bekendtgjort den: **2017-03-13**
- (80) Dato for Den Europæiske Patentmyndigheds bekendtgørelse om meddelelse af patentet: **2016-12-07**
- (86) Europæisk ansøgning nr.: **15169153.2**
- (86) Europæisk indleveringsdag: **2015-05-26**
- (87) Den europæiske ansøgnings publiceringsdag: **2016-03-02**
- (30) Prioritet: **2014-08-29 IT VR20140217**
- (84) Designerede stater: **AL AT BE BG CH CY CZ DE DK EE ES FI FR GB GR HR HU IE IS IT LI LT LU LV MC MK MT NL NO PL PT RO RS SE SI SK SM TR**
- (73) Patenthaver: **Pedrollo S.p.a., Via Enrico Fermi, 7, 37047 San Bonifacio (Verona), Italien**
- (72) Opfinder: **PEDROLLO, Silvano, Via 4 Spade, 18, 37100 Verona, Italien**
- (74) Fuldmægtig i Danmark: **Plougmann Vingtoft A/S, Rued Langgaards Vej 8, 2300 København S, Danmark**
- (54) Benævnelse: **EN INDRETNING TIL AT STYRE EN START OG ET STOP AF EN ELEKTROMOTOR AF EN MOTORDREVEN PUMPE**
- (56) Fremdragne publikationer:
EP-A1- 1 074 745
EP-A1- 1 775 476
EP-A2- 0 459 434
EP-A2- 0 819 851

DESCRIPTION

[0001] The present invention relates to an apparatus for controlling the starting and stopping of an electric motor of a motor-driven pump.

[0002] The invention concerns the technical sector of motor-driven pumps configured for collecting and sending fluids, typically liquids, such as for example water, oils and fuels and other liquids for civic or industrial use. In particular, the invention is advantageously applicable in the sector of submersible motor-driven pumps.

[0003] An example of the water-submersible electric pump is disclosed, for example, in document WO 2014/042630.

[0004] Further examples of the claimed device are also known from EP0459434A, EP1775476A, EP1074745A or EP0819851 A.

[0005] Typically, a motor-driven pump comprises a pump body, which houses the electric motor and one or more impellers that collect water from a drawing basin, for example a well, a tank, a tank and the like, for sending to a user device; generally, the impellers are directly keyed on the drive shaft of the electric motor. More in detail, the electric motor is protected by a watertight liner, so as to prevent the electrical parts of the motor from entering into contact with the water. The motor-driven pump further comprises a delivery body connected to the pump body; in greater detail, a delivery conduit is located internally of the delivery body and is in fluid communication with the impellers.

[0006] According to the prior art, the motor-driven pumps are provided with an automatic start and stop electronic system for the electric motor, as a function of the request for liquid (for example, water) by the user or as a protection for preventing the "dry" operation of the motor-driven pump, that is to say, the operation of the electric motor in the absence of liquid in the drawing basin.

[0007] The electronic automatic start and stop systems comprise an electronic control unit, for example a PLC (Program Logic Control), which controls starting and stopping of the electric motor, as a function of electrical signals coming from a flow rate probe and from a pressure probe. The electronic control unit is housed in a watertight container, for preventing contact between the liquid and the electronic components of the control unit. The flow rate probe is positioned in the delivery conduit so as to be struck by the flow of fluid created by the impellers on request by the user.

[0008] The pressure probe has a side directly interfaced with the electronic control unit and a side equipped with a pressure detector configured for entering into contact with the liquid. In particular, the pressure probe is physically coupled to the electronic control unit and faces the delivery conduit via a pressure detector surrounded by a seal gasket, which guarantees the watertight state of the container in which the electronic control unit is housed.

[0009] In the prior art, the electronic automatic start and stop systems have some important drawbacks.

[0010] Firstly, if the pressure probe breaks, the fluid comes into contact with the components of the electronic control unit, the unit being directly coupled to the pressure probe.

[0011] Secondly, maintenance of the electronic system is particularly complex, as it is necessary to access and demount two different probes. Moreover, it is disadvantageously necessary to take special attention in removing the pressure probe, so as to prevent residues of liquid from penetrating inside the watertight container, and coming into contact with the components of the electronic control unit. To access the pressure probe, in fact, it has to be decoupled from the electronic control unit, leaving an opening in the watertight container.

[0012] Further, the electronic systems of known type disadvantageously have a complex architecture, which requires a sufficient space for positioning both the probes, with consequent complications at the technical design stage of the electric pump and the dimensions thereof.

[0013] In this context, the technical purpose which forms the basis of the invention is to provide an apparatus for controlling starting and stopping of an electric motor of a motor-driven pump, which obviates the above mentioned drawbacks of the prior art. More specifically, the aim of the invention is to provide an apparatus that has no direct physical interface between liquid and electrical/electronic components of the apparatus.

[0014] A further aim of the invention is to disclose an apparatus exhibiting a small number of components and a simple architecture.

[0015] A further aim of the this invention is to disclose an apparatus for controlling the starting and stopping of an electric motor of a motor-driven pump, which is able to simplify the maintenance and cleaning operations.

[0016] Another aim of the invention is to disclose an apparatus for controlling the starting and stopping of an electric motor of a motor-driven pump, able to prevent "dry" operation of the electric pump.

[0017] The set technical purpose and the specified aims are substantially attained by an apparatus for controlling the starting and stopping of an electric motor of a motor-driven pump comprising the technical characteristics described in one or more of the appended claims. The dependent claims correspond to further embodiments of a method according to the invention.

[0018] Further characteristics and advantages of this invention will become more apparent in the detailed description that follows, with reference to a preferred and non-exclusive embodiment of an electric motor of a motor-driven pump as illustrated in the accompanying drawings, in which:

- figure 1 is a perspective overall view in cross section of a motor-driven pump equipped with an apparatus for controlling starting and stopping of an electric motor, in accordance with the invention;
- figure 2 is a front view of a first embodiment of a component of the apparatus, in accordance with the invention;
- figure 3 shows a front view in cross section of the valve shown in figure 2;
- figures 2A, 3A illustrate the component shown in figures 2 and 3 in two different operating configurations;
- figure 4 is a front view of a second embodiment of a component of the apparatus, in accordance with the invention;
- figure 5 is a front view in cross section of the component illustrated in figure 4;
- figures 4A, 5A illustrate the component shown in figures 4 and 5 in two different operating configurations;
- figure 6 is a front view of a third embodiment of a component of the apparatus, in accordance with the invention;
- figure 7 is a front view in cross section of the component illustrated in figure 6;
- figures 6A, 7A illustrate the component shown in figures 6 and 7 in two different operating configurations.

[0019] With reference to the figures, reference numeral 1 indicates in its entirety a motor-driven pump, in particular of a type that is submersible in a liquid, preferably in water.

[0020] The motor-driven pump 1 comprises a pump body 2, which houses an electric motor 3 and at least an impeller 4, preferably three or more impellers in the illustrated example, which draws water to be drained from a drawing basin, for example a well, a tank, a tank and the like, for sending to a user. In the illustrated example, but without constituting a limitation, the impellers 4 are directly keyed on a drive shaft 3a of the electric motor 3.

[0021] The electric motor 3 is protected by a watertight liner 3b, so as to prevent the electrical parts of the motor from entering into contact with the water.

[0022] The motor-driven pump 1 also comprises a delivery body 5 connected to the pump body 2; in more detail, a delivery conduit 5a is located inside the delivery body 5 which is in fluid communication with the impellers 4.

[0023] The motor-driven pump 1 is equipped with an apparatus 100 for controlling the starting and stopping of the electric motor 3. In greater detail, the apparatus comprises a flow rate detector 101 configured such as to be immersed in a fluid and to be movable between a home position, corresponding to the absence of fluid flow condition, and an operating position, corresponding to the presence of a fluid flow; a pressure detector 102 configured so as to interact with a fluid and movable between at least two positions depending on a pressure applied by the fluid;

- a control apparatus 103 designed to detect a movement of the flow rate detector 101 and a movement of the pressure detector 102; in more detail, the control apparatus commands the starting and stopping of the electric motor 3 depending on the movements detected.

[0024] In particular with reference to figures 2A, 3A, 4A, and 5A, the pressure detector 102 is at least partly housed in a chamber 104 made in the flow rate detector 101, in such a way as to form a single integrated flow rate and pressure probe 200 able to be housed in the delivery conduit 5a of the electric pump 1; in more detail, the chamber 104 is configured so as to place the

pressure detector 102 in fluid communication with the delivery conduit 5a, as explained in the following of the present description.

[0025] With reference in particular to figures 2, 3, 4, 5, 6 and 7 the flow rate detector 101 comprises a containment body 105, internally of which the chamber 104 is fashioned, destined to house the pressure detector 102. Further, a closing element 106 is present, coupled to the containment body 105 for keeping the pressure detector 102 stably housed internally of the chamber 104, the closing element 106 comprising an opening 107a for placing the pressure detector 102 in fluid communication with a delivery conduit 5a of a motor-driven pump 1.

[0026] The closing element 106 has an expansion 106a, preferably with a vertical extension, designed to support an elastic element 107 (visible in figure 1), preferably a helical spring. In more detail, the elastic element 107 is inserted coaxially on the expansion 106a so as to act between a base portion 106b of the closing element and a contact portion 5b (visible in figure 1) of the delivery conduit 5a of the motor-driven pump 1, in such a way as to keep or return the integrated probe 200 into the rest position, when the flow rate detector 101 detects no flow, that is to say, when it verifies the absence of the fluid flow condition. The presence of the elastic element 107 advantageously enables the integrated probe 200 also to operate in a horizontal direction.

[0027] In accordance with the preferred and illustrated variant embodiment, the containment body 105 and the closing element 106 are connected by reversible fixing means, preferably by three or more screws 110. In accordance with embodiments that are not illustrated, it is possible for the containment body 105 and the closing element 106 to be welded together, for example by ultrasound welding.

[0028] With reference in particular to the variant embodiment illustrated in figures 6A and 7A, the pressure detector 102 comprises a slider 108 slidably movable inside the chamber 104 by effect of the pressure applied by the fluid; in more detail, the slider moves between at least a home position (figure 6a), in the absence of fluid pressure, and a switched position (figure 7a), in the presence of fluid pressure. In addition, the slider 108 is equipped with at least a seal ring 108a, for confining the fluid inside the chamber 104.

[0029] With reference in particular to the variant embodiment illustrated in figures 2A, 3A, 4A and 5A, the pressure detector may also comprise a membrane 112 forming a cavity 102a for receiving the fluid; in more detail, the membrane 112 deforms under the action of the pressure applied by the fluid and varies its shape between a substantially non-deformed home configuration (figures 2A and 4A), corresponding to the absence of fluid pressure, and a deformed operating configuration (figures 3A and 5A), corresponding to the presence of fluid pressure. In more detail, the slider 108 is maintained in contact with the membrane 112, so that the slider moves by effect of the deformation of the membrane, as a function of the fluid pressure.

[0030] With reference in particular to figures 2A-7A, the movement of the slider 8 is preferably opposed by a helical spring 118 inserted in the chamber 104, in such a way as to develop a pre-loading by the effect of a squeezing action designed to position it in stably between a bottom portion of the chamber 104 and a portion of the slider 8.

[0031] The control apparatus 103 comprises:

a first signal emitter 113a, preferably for a signal of a magnetic and/or electrical type, associated with the flow rate detector 101;

- a second signal emitter 123a, preferably for a signal of the magnetic and/or electric type, associated with the pressure detector 102;
- a processing unit 133 (figure 1) comprising a first sensor 113b designed to receive the signal emitted by the first emitter 113a and a second sensor 123b designed to receive the signal emitted by the second emitter 123a, said sensors 113b, 123b interpreting the signals received as being representative of physical parameters of movement of the flow rate detector 101 and of movement of the pressure detector 102;
- a control unit 143 (figure 1) for controlling the starting and stopping of an electric motor 3 of a motor-driven pump 1 according to instructions received from the processing unit 133, depending on the signals received by the sensors 113b, 123b. For the sake of simplicity, reference will be made in the following to the first sensor 113b with the term "flow rate sensor", whilst the second sensor 123b will be called the "pressure sensor".

[0032] Even more preferably, each of the emitters 113a, 123a of a signal comprises a permanent magnet, whilst each of the sensors 113b, 123b is of the Hall effect type.

[0033] With reference to figure 1, the processing unit 133 and the control unit 143 are housed in a box-shaped watertight body 153, which is isolated from the delivery conduit 5a of the motor-driven pump 1; more specifically, the box-shaped body 153 is

physically distinct and separated from the integrated flow-rate and pressure probe 200 defined by the flow rate detector 101 and from the pressure detector 102, according to the general architecture described in the foregoing.

[0034] In more detail and in accordance with figures, the first signal emitter 113a is fixed on the containment body 105, while the second signal emitter 123a is installed on the slider 108 slidably movable internally of the chamber 104.

[0035] In accordance with the variant embodiment illustrated in figures 4, 4A, 5e 5A, the containment body 105 has an opening 107b for fluid communication located on the side opposite an opening 102b (figures 3A, 5A) affording access to the cavity 102a defined by the membrane. More specifically, the opening 107b for fluid communication is afforded at a sliding zone of the slider 108 inside the chamber 104. The communication opening 107b advantageously reduces the pumping effect induced by the motion of the slider 108, significantly increasing the operating precision of the control apparatus.

[0036] In accordance with the variant embodiment illustrated in figures 6A and 7A, the containment body 105 has an opening 107b for fluid communication located on the opposite side to an opening 112b affording access to the chamber 104. More specifically, the opening 107b for fluid communication is afforded at a sliding zone of the slider 108 inside the chamber 104. Similarly to what is described with reference to the variant embodiment shown in figures 4, 4A, 5 and 5A, the communication opening 107b advantageously reduces the pumping effect induced by the motion of the slider 108, significantly increasing the operating precision of the control apparatus.

[0037] As will become clearer in the detailed description of the operation of the invention, the processing unit 113 is designed in such a way as to perform one or more of the following operations:

- with the electric motor of the motor-driven pump operating, sending the control unit 123 the instruction to keep the electric motor 3 active, at least until the first sensor 113b receives the signal arriving from the first emitter 113a associated with the flow rate detector 101;
- with the electric motor of the motor-driven pump operating, sending the control unit 123 the instruction to stop the electric motor 3 when, respectively, the first sensor 113b receives the signal arriving from the first emitter 113a associated with the flow rate detector 101 and the second sensor 123b receives, within a predetermined period of time, the signal arriving from the second emitter 123a associated with the pressure detector 102;
- with the electric motor of the motor-driven pump switched off, sending the control unit 123 the instruction to switch on the electric motor 3, when the first sensor 113b receives the signal arriving from the first emitter 113a associated with the flow rate detector 101 and the second sensor 123b, after previously having received the signal arriving from the second emitter 123a, no longer receives any signal;
- with the electric motor of the motor-driven pump operating, sending the control unit 123 the instruction to stop the electric motor 3 when, respectively, the first sensor 113b receives the signal arriving from the first emitter 113a associated with the flow rate detector 101 and the second sensor 123b does not receive, within a predetermined period of time, the signal arriving from the second emitter 123a associated with the pressure detector 102, in that configuration, the processing unit 113 preventing a new switching-on of the electric motor for a predetermined subsequent period of time.

[0038] In greater detail, the invention operates as follows.

[0039] In operating conditions of the with water being dispensing to a user, the impellers 4 set up a continuous flow of fluid (water) which imparts an upwards movement of the integrated probe 200, that is to say, a movement towards an outlet opening 5c of the delivery conduit 5a. In this condition (figures 2A, 4A), the first emitter 113a associated with the flow rate detector 101 distances from the flow rate sensor 113b, which therefore does not receive any signal; the second emitter 123a associated with the pressure detector 102 (the membrane of which is still in the home configuration and thus not deformed) also distances from the pressure sensor 123b, which therefore does not receive any signal. In these conditions, the processing unit sends an instruction to the control unit to keep the electric motor 3 switched on, as it recognises that the user requires water, that there is a flow of liquid and that it is correctly flowing.

[0040] When there is a block in the dispensing of the water, typically when the user closes a valve or dispensing stopcock, the flow of fluid (water) stops and the integrated probe 200 returns into the rest configuration corresponding to the home configuration of the flow rate detector 101. In other words, by action of the recall force applied by the elastic element 107, and also the force of gravity (if installed vertically), the integrated probe 200 moves downwards, away from the outlet opening 5c of the delivery conduit 5a. Following closure of the valve or dispensing stopcock, after a certain passage of time a pressure is established in the remaining liquid (water) in the delivery conduit 5a and in the cavity 102a of the membrane of the pressure

detector 102 which, as explained in the foregoing, is in fluid communication with the delivery conduit 5a through by means of the access opening 102b and of the opening 107a made on the closing element 106. The pressure of the liquid determines a deformation of the membrane 102, which causes a downwards movement of the slider 108, that is to say, distancingly from the delivery conduit 5a. In this condition (figures 3A, 5A), the first emitter 113a associated with the flow rate detector 101 is positioned at the flow rate sensor 113b, which therefore receives a signal; the second emitter 123a associated with the pressure detector 102 (the membrane of which is in operating configuration and therefore deformed) is positioned, after a predetermined passage of time, at the pressure sensor 123b, which therefore receives a signal. In these conditions, the processing unit sends an instruction to the control unit to switch the electric motor 3 off, as it recognises that the user has blocked dispensing of water and that the flow of liquid in the delivery conduit 5a has therefore stopped. When the user re-opens the valve or the stopcock for activating a new dispensing of liquid (water), there is a pressure drop inside the delivery conduit 5a and therefore in the cavity 102a of the membrane of the pressure detector 102; the drop in pressure of the liquid determines a return of the membrane 102 into the non-deformed home configuration, which causes an upwards movement of the slider 108, i.e. towards the delivery conduit 5a. In this condition (figures 3A, 5A), the first emitter 113a associated with the flow rate detector 101 is positioned at the flow rate sensor 113b, which therefore receives a signal; in the meantime, the second emitter 123a associated with the pressure detector 102 (the membrane of which has returned into the non-deformed home position) distances from the pressure sensor 123b, which therefore does not receive a signal. In these conditions, the processing unit sends an instruction to the control unit to newly switch on the electric motor 3, as it recognises that the user has newly activated the water dispensing and that water is available to be dispensed.

[0041] The control apparatus 103 is advantageously able to prevent "dry" operation of the electric pump 1. In fact, in a case where the electric motor 3 is switched on, but there is no fluid flow inside the delivery conduit 5a, the integrated probe 200 does not displace from the rest configuration corresponding to the home configuration of the flow rate detector 101. In these conditions, the first signal emitter 113a is at the flow rate sensor 113b, which therefore receives a signal; in the meantime, the second signal 123a emitter is distanced from the pressure sensor 123b, which therefore does not receive a signal, nor has it received a signal in an immediately-preceding time interval. In these conditions, the processing unit sends an instruction to the control unit to switch off the electric motor 3, as it recognises that no fluid flow has been established, notwithstanding the operating of the motor-driven pump 3, and that there is therefore no availability of liquid to dispense.

[0042] In the initial transitory conditions which correspond to the first motor-driven pump connection to the electricity mains, the control apparatus 103 switches on the electric motor 3 and, according to whether the user valve is open or closed, implements the predetermined checks and the adjustments, respectively for the liquid dispensing condition or the blocked dispensing condition, in the above-illustrated way.

[0043] The invention offers the following advantages.

[0044] First of all, the apparatus for controlling the starting and stopping of the electric motor in accordance with the invention prevents any contact between the fluid and the electronic components of the apparatus, including in the event of failure of any of the flow rate or pressure detectors. The integrated probe 200, in effect, does not have any direct physical interface or other material coupling with the processing unit and the monitoring control unit, unlike in the prior art. In particular, the interaction between the integrated probe 200 and the processing and command unit is achieved only by means of remote interaction, preferably of a magnetic type.

[0045] The presence of a single integrated probe 200 for detecting pressure and flow rate advantageously considerably simplifies the architecture of the apparatus for controlling the starting and stopping of the electric motor. Still more advantageously, the presence of a single integrated probe 200 for detecting pressure and flow rate simplifies maintenance and cleaning operations, as an operator has to demount and/or clean one part only.

[0046] A further advantage is that pump functioning is guaranteed, even in the presence of faults in the integrated probe 200. In fact, given the high level of integration between the flow rate detector and the pressure detector, in the case of a malfunction the integrated probe can be easily removed without compromising the other pump members, the pump therefore being able to operate as usual; in this case, the control carried out by the integrated probe will be missing, but - in emergency conditions - the delivery of the fluid to a user is advantageously not interrupted, for example supply to an irrigation plant.

[0047] It has been found in practice that an apparatus for controlling the starting and stopping of an electric motor of a motor-driven pump, according to the invention, attains the specified aims.

REFERENCES CITED IN THE DESCRIPTION

This list of references cited by the applicant is for the reader's convenience only. It does not form part of the European patent document. Even though great care has been taken in compiling the references, errors or omissions cannot be excluded and the EPO disclaims all liability in this regard.

Patent documents cited in the description

- WO2014042630A [0003]
- EP0459434A [0004]
- EP1775476A [0004]
- EP1074745A [0004]
- EP0819851A [0004]

Patentkrav

1. Indretning (100) til at styre starten og stoppet af en elektromotor (3) af en motordreven pumpe (1), hvilken indretning (100) omfatter:

5 en strømningsmængdedetektor (101) designet til at blive nedsænket i en fluid og til at være bevægelig mellem en startposition, svarende til fraværet af fluidstrømningsstilstand, og en driftsposition, svarende til tilstedeværelsen af fluidstrømningsstilstand;

10 en trykdetektor (102) designet til at indvirke med en fluid og bevægelig mellem mindst to positioner afhængigt af et tryk påført af fluiden;

15 et styringsapparat (103) designet til at detektere en bevægelse af strømningsmængdedetektoren (101) og en bevægelse af trykdetektoren (102), hvilket styringsapparat (103) styrer starten og stoppet af en elektromotor (3) af en motordreven pumpe (1) afhængigt af de detekterede bevægelser,

20 **kendetegnet ved at** trykdetektoren (102) er mindst delvist huset i et kammer (104) lavet i strømningsmængdedetektoren (101) på sådan en måde for at danne en integreret strømningsmængde- og trykføler (200) der kan huses i en leveringsledning (5a) af en motordreven pumpe (1), hvor kammeret (104) er designet til at sætte trykdetektoren (102) i fluidforbindelse med leveringsledningen (5a).

25 **2.** Indretningen ifølge det foregående krav, hvor trykdetektoren (102) omfatter en glider (108) glidbart bevægelig inden i kammeret (104) på grund af trykket påført af fluiden, hvilken glider bevæger sig mellem mindst en startposition, i fraværet af fluidtryk, og en skiftet position, i tilstedeværelsen af fluidtryk.

30 **3.** Indretningen ifølge krav 2, hvor glideren (108) omfatter mindst en fluidtætningsring (108a) til at holde fluiden inden i kammeret (104).

4. Indretningen ifølge krav 2, hvor trykdetektoren (102) omfatter en membran, der danner et hulrum (102a) til at modtage fluiden, hvilken membran deformeres under påvirkningen af trykket påført af fluiden og varierer sin form mellem en i alt væsentligt ikke-deformeret startkonfiguration, svarende til fraværet af fluidtryk, 5 og en deformeret driftskonfiguration, svarende til tilstedeværelsen af fluidtryk, hvor glideren holdes i forbindelse med membranen, hvorved glideren (108) bevæger sig på grund af deformationen af membranen.

5. Indretningen ifølge et hvilket som helst af de foregående krav, hvor 10 styringsapparatet (103) omfatter:

en første signaludsender (113a), fortrinsvis for et signal af den magnetiske og/eller elektriske type, associeret med strømningsmængdedetektoren (101);

15 en anden signaludsender (123a), fortrinsvis for et signal af den magnetiske og/eller elektriske type, associeret med trykdetektoren (102);

en behandlingsenhed (133) omfattende en første sensor (113b) designet til at modtage signalet udsendt af den første udsender (113a) og en anden sensor (123b) designet til at modtage signalet udsendt af den anden udsender (123a), hvilke sensorer (113b, 123b) fortolker de modtagne 20 signaler som værende repræsentative for fysiske parametre for bevægelse af strømningsmængdedetektoren (101) og bevægelse af trykdetektoren (102);

25 en styreenhed (143) til at styre starten og stoppet af en elektromotor (3) af en motordreven pumpe (1) i henhold til instruktioner modtaget fra behandlingsenheden (133), afhængigt af signalerne modtaget af sensorerne (113b, 123b).

6. Indretningen ifølge krav 5, hvor den første signaludsender (113a) er fastgjort på et beholderlegeme (105) af strømningsmængdedetektoren (101) og den anden 30 signaludsender (123a) er installeret på glideren (108)

7. Indretningen ifølge et hvilket som helst af de foregående krav, hvor strømningmængdedetektoren (101) omfatter:

et beholderlegeme (105) i hvilket kammeret (104) er lavet for at huse trykdetektoren (102);

5 et lukkeelement (106) koblet til beholderlegemet (105) for at holde trykdetektoren (102) stabilt huset i kammeret (104), hvilket lukkeelement (106) omfatter en åbning (107a) til at sætte trykdetektoren (102) i fluidforbindelse med en leveringsledning (5a) af en motordreven pumpe (1);

10 et elastisk tilbagetrækningselement (107) fastgjort på en forlængelse (106a) af lukkeelementet (106) og der virker mellem en del (106b) af lukkeelementet (106) og en del (5b) af en leveringsledning (5a) af en motordreven pumpe (1), for at holde eller trække den integrerede føler (200) tilbage i startpositionen, når fluidstrømningen er fraværende.

15

8. Indretningen ifølge krav 7, hvor beholderlegemet (105) og lukkeelementet (106) er forbundet ved hjælp af reversibelt fastgørelsesorgan, fortrinsvis af mindst en skrue (110).

20 **9.** Indretningen ifølge krav 7, når afhængigt af krav 2, hvor beholderlegemet (105) omfatter en fluidforbindelsesåbning (107b) lokaliseret på den modstående side af en adgangsåbning (112b) af kammeret (104), hvor fluidforbindelsesåbningen (107b) er lavet ved en glidezone af glideren (108) inden i kammeret (104).

25

10. Indretningen ifølge krav 7, når afhængigt af krav 4, hvor beholderlegemet (105) omfatter en fluidforbindelsesåbning (107b) lokaliseret på den modstående side til en adgangsåbning (102b) af hulrummet (104) dannet af membranen, hvor fluidforbindelsesåbningen (107b) er lavet ved en glidezone af glideren (108) inden
30 i kammeret (104).

- 11.** Indretningen ifølge krav 5 eller 6, hvor hver af signaludsenderne (113a, 123a) omfatter en permanent magnet.
- 12.** Indretningen ifølge krav 5 eller 6, hvor hver af sensorerne (113b, 123b) er af
5 Hall effekt-typen.
- 13.** Indretningen ifølge et hvilket som helst af kravene 5 til 12, hvor behandlingsenheden (133) er designet på sådan en måde at den udfører en eller flere af de følgende handlinger:
- 10 - med elektromotoren (3) af en motordreven pumpe (1) i drift, at sende til styreenheden (123) instruktionen at holde elektromotoren (3) aktiv, mindst indtil den første sensor (113b) modtager signalet, der kommer fra den første udsender (113a) associeret med strømningsmængdedektoren (101);
- 15 - med elektromotoren (3) af en motordreven pumpe (1) i drift, at sende til styreenheden (123) instruktionen at stoppe elektromotoren (3) når, henholdsvis, den første sensor (113b) modtager signalet, der kommer fra den første udsender (113a) associeret med strømningsmængdedektoren (101), og den anden sensor (123b) modtager, inden for en forudindstillet
20 tidsperiode, signalet, der kommer fra den anden udsender (123a) associeret med trykdetektoren (102);
- med elektromotoren (3) af en motordreven pumpe (1) slukket, at sende til styreenheden (123) instruktionen at tænde elektromotoren (3), når den
25 første sensor (113b) modtager signalet, der kommer fra den første udsender (113a) associeret med strømningsmængdedektoren (101), og den anden sensor (123b), efter tidligere at have modtaget signalet, der kommer fra den anden udsender (123a), ikke længere modtager noget signal;
- 30 - med elektromotoren (3) af en motordreven pumpe (1) i drift, at sende til styreenheden (123) instruktionen at stoppe elektromotoren (3) når, henholdsvis, den første sensor (113b) modtager signalet, der kommer fra

den første udsender (113a) associeret med strømningsmængdedetektoren, (101) og den anden sensor (123b) ikke modtager, inden for en forudindstillet tidsperiode, signalet, der kommer fra den anden udsender (123a) associeret med trykdetektoren (102), i den konfiguration, 5
behandlingsenheden (113) forhindrer en ny tænding af elektromotoren i en forudbestemt efterfølgende tidsperiode.

14. Indretningen ifølge et hvilket som helst af kravene 5 til 13, hvor behandlingsenheden (133) og styreenheden (143) er huset i et fluidtæt 10
kasseformet legeme (153), isoleret fra en leveringsledning (5a) af en motordreven pumpe (1), hvor det kasseformede legeme (153) er fysisk separat fra den integrerede strømningsmængde- og trykføler (200).

15. Motordreven pumpe (1) med en elektromotor, **kendetegnet ved at** den 15
omfatter en indretning (100) til at styre starten og stoppet af elektromotoren (3), ifølge et hvilket som helst af de foregående krav.

DRAWINGS

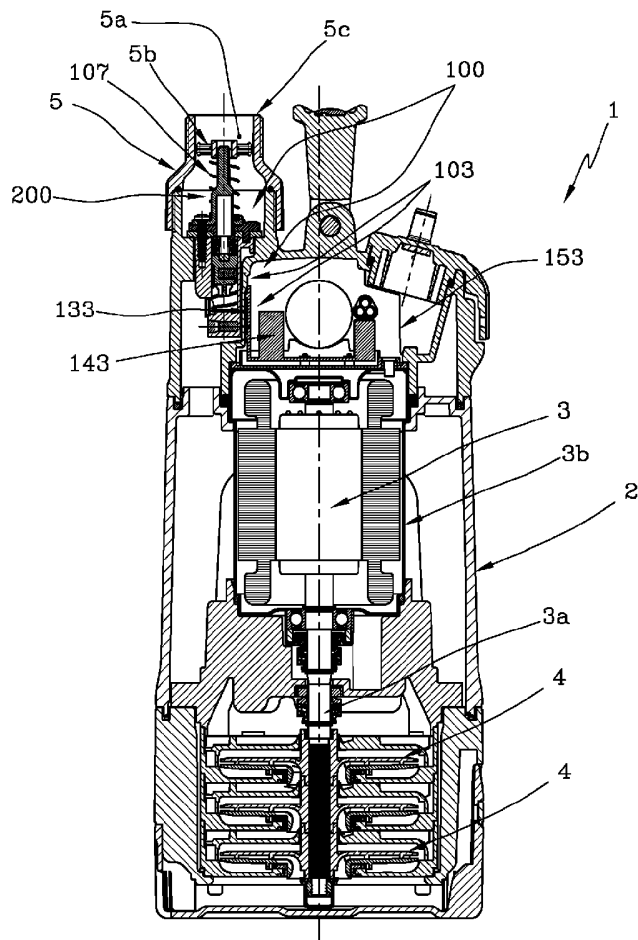

FIG. 1

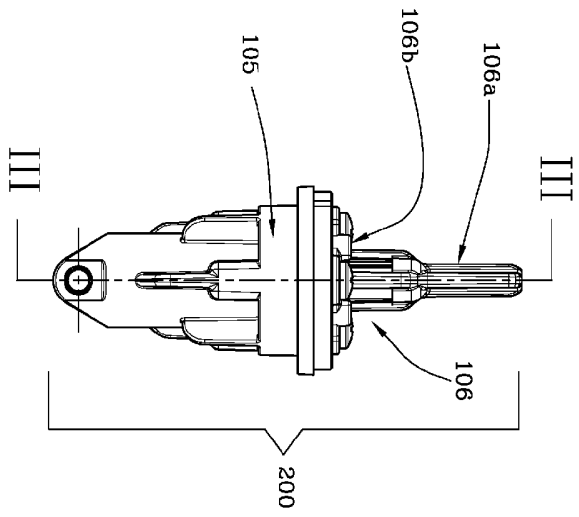

FIG. 2

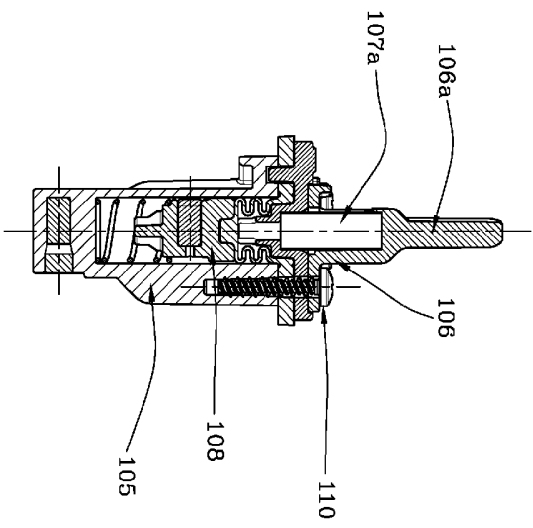

FIG. 3

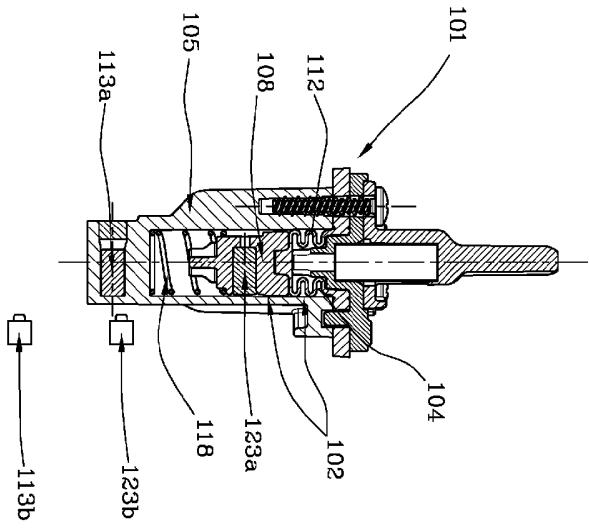

FIG. 2A

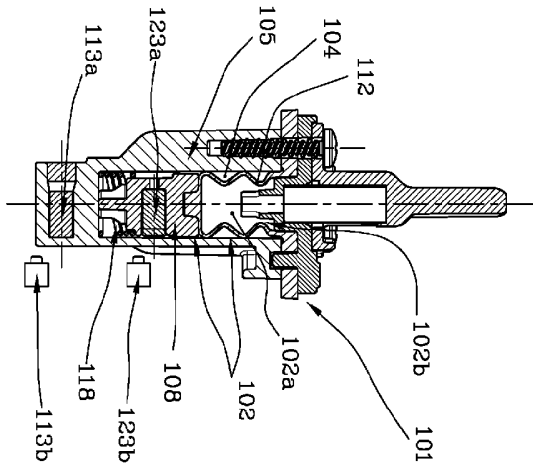

FIG. 3A

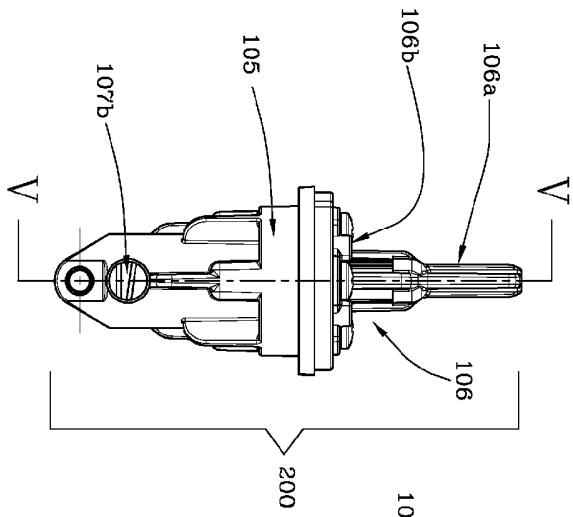

FIG. 4

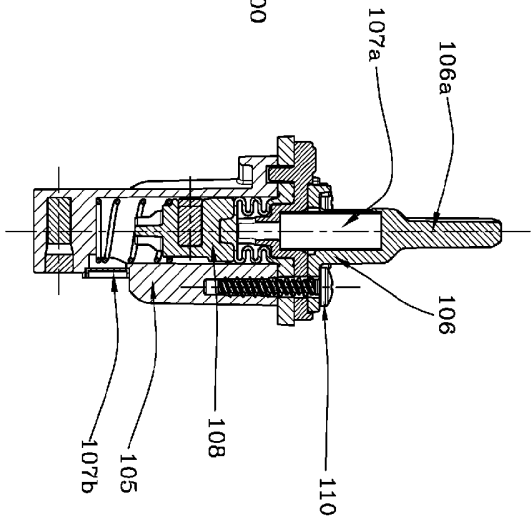

FIG. 5

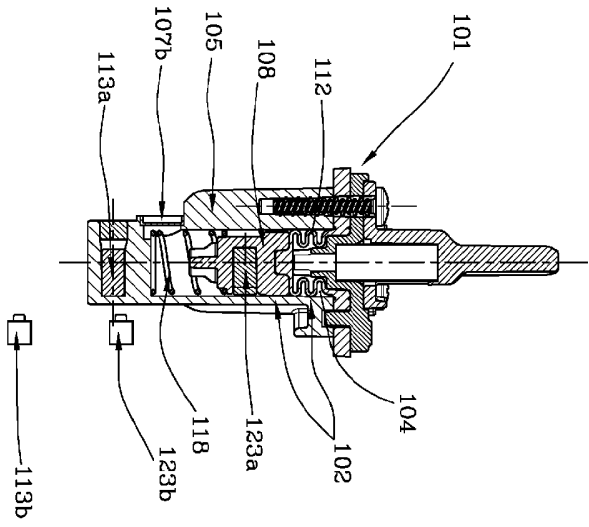

FIG. 4A

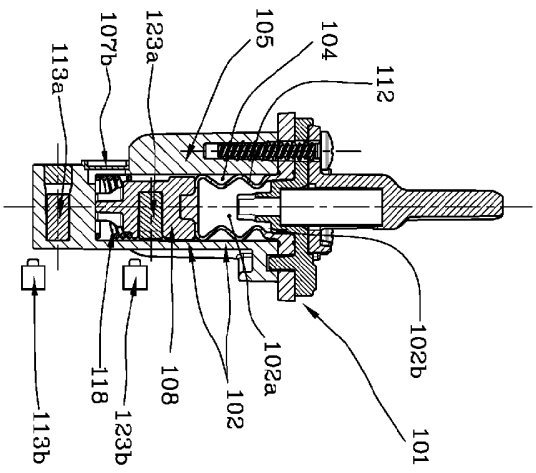

FIG. 5A

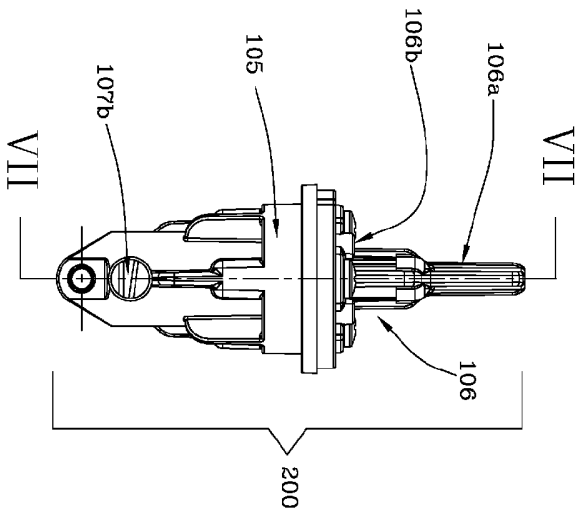

FIG. 6

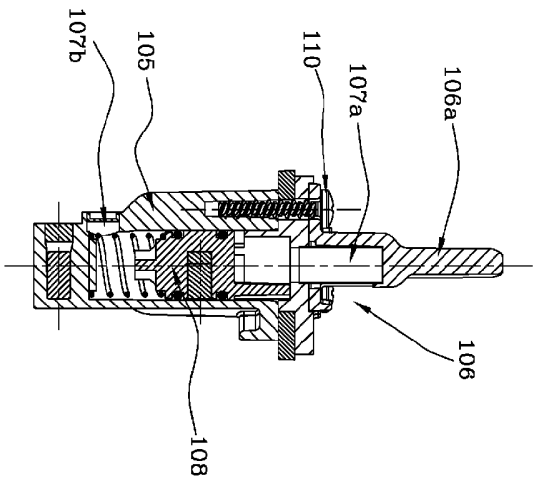

FIG. 7

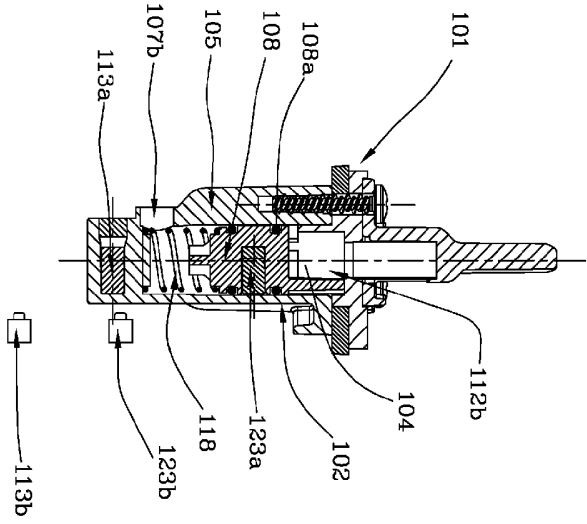

FIG. 6A

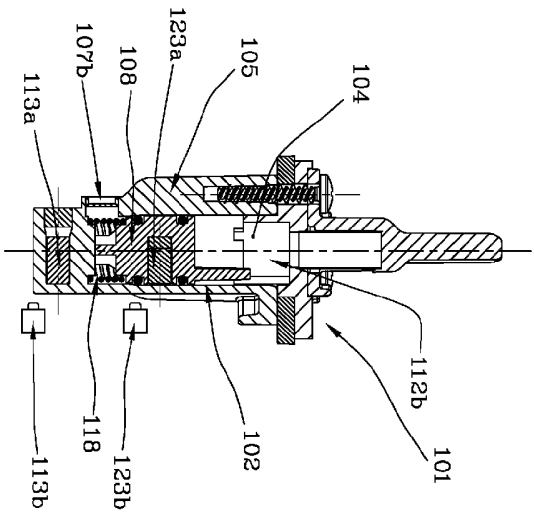

FIG. 7A