



- (51) **International Patent Classification:**
A45D 34/04 (2006.01) A45D 40/26 (2006.01)
- (21) **International Application Number:**
PCT/IB2010/051062
- (22) **International Filing Date:**
11 March 2010 (11.03.2010)
- (25) **Filing Language:** English
- (26) **Publication Language:** English
- (30) **Priority Data:**
09 51510 11 March 2009 (11.03.2009) FR
61/169,746 16 April 2009 (16.04.2009) US
- (71) **Applicant (for all designated States except US):** L'OREAL [FR/FR]; 14 rue Royale, F-75008 Paris (FR).
- (72) **Inventor; and**
- (75) **Inventor/Applicant (for US only):** GUERET, Jean-Louis [FR/FR]; 27 avenue Raymond Poincaré, F-75016 Paris (FR).
- (74) **Agent:** TANTY, François; Nony, 3 rue de Penthièvre, F-75008 Paris (FR).

- (81) **Designated States (unless otherwise indicated, for every kind of national protection available):** AE, AG, AL, AM, AO, AT, AU, AZ, BA, BB, BG, BH, BR, BW, BY, BZ, CA, CH, CL, CN, CO, CR, CU, CZ, DE, DK, DM, DO, DZ, EC, EE, EG, ES, FI, GB, GD, GE, GH, GM, GT, HN, HR, HU, ID, IL, IN, IS, JP, KE, KG, KM, KN, KP, KR, KZ, LA, LC, LK, LR, LS, LT, LU, LY, MA, MD, ME, MG, MK, MN, MW, MX, MY, MZ, NA, NG, NI, NO, NZ, OM, PE, PG, PH, PL, PT, RO, RS, RU, SC, SD, SE, SG, SK, SL, SM, ST, SV, SY, TH, TJ, TM, TN, TR, TT, TZ, UA, UG, US, UZ, VC, VN, ZA, ZM, ZW.
- (84) **Designated States (unless otherwise indicated, for every kind of regional protection available):** ARIPO (BW, GH, GM, KE, LS, MW, MZ, NA, SD, SL, SZ, TZ, UG, ZM, ZW), Eurasian (AM, AZ, BY, KG, KZ, MD, RU, TJ, TM), European (AT, BE, BG, CH, CY, CZ, DE, DK, EE, ES, FI, FR, GB, GR, HR, HU, IE, IS, IT, LT, LU, LV, MC, MK, MT, NL, NO, PL, PT, RO, SE, SI, SK, SM, TR), OAPI (BF, BJ, CF, CG, CI, CM, GA, GN, GQ, GW, ML, MR, NE, SN, TD, TG).

Published:

— with international search report (Art. 21(3))

(54) **Title:** AN APPLICATOR DEVICE INCLUDING A VIBRATION SOURCE

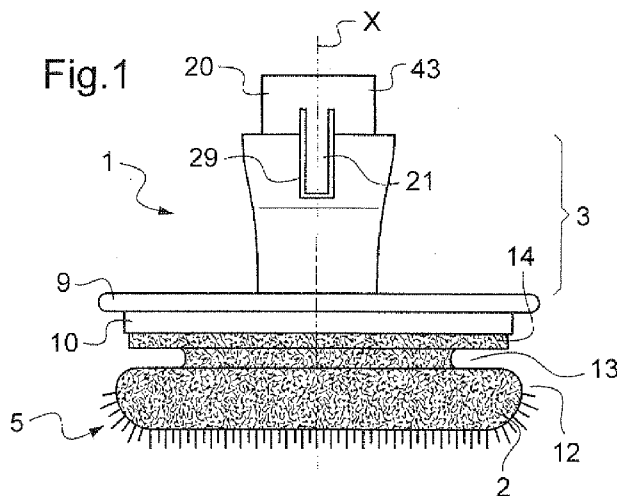

(57) **Abstract:** The present invention relates to an applicator device (1) for applying a composition to the skin, the device comprising: • a vibration source (20); • a handle portion (3); and • an applicator member (2) that is secured to the handle portion, at least during application; the applicator member presenting a distal face (5) for contacting the skin, the applicator member (2) including, in at least one region of the distal face (5) that comes into contact with the skin: • a flocked felt; • a flocked sintered element; • a foam covered in fibers that are formed of flocking of different lengths and/or of different shapes; • a foam that includes fibers that are formed of burst foam cell walls; and/or • portions in relief of height lying in the range 0.1 mm to 2 mm, which portions are not associated with the intrinsic structure of a material defining the distal face.

WO 2010/103485 A1

AN APPLICATOR DEVICE INCLUDING A VIBRATION SOURCE

The present invention relates to applicator devices for applying a cosmetic or dermatological composition to the skin.

5 Devices are known including an applicator member that is secured to a handle portion and that has a distal face that is relatively large for coming into contact with the skin. Such devices are suitable in particular for applying a composition to the body or the face.

10 US patents Nos. 7 156 752 B2 and 6 773 187 B2 describe devices of that type in which the distal face presents a central concave shape, or portions in relief such as beads or ribs.

 Devices are also known having an application surface
15 that is defined by a membrane that is smooth, or even flocked.

 A problem that may arise with known applicators is excessive adhesion to the skin in the presence of composition, thereby braking the movement of the
20 applicator member over the skin and/or creating a suction effect.

 Thus, the composition might not be as comfortable to apply as desired.

 Publication WO 2006/090343 teaches associating a
25 vibration source with an applicator device for applying a composition to the skin.

 There exists a need to improve still further applicator devices for applying a composition to the skin, in particular in order to obtain increased comfort
30 in application.

 Exemplary embodiments of the invention provide an applicator device for applying a composition to the skin, the device comprising:

- a vibration source;
- 35 • a handle portion; and
- an applicator member that is secured to the handle portion, at least during application;

the applicator member presenting a distal face for contacting the skin, the applicator member including, in at least one region of the distal face that comes into contact with the skin:

- 5 • a flocked felt;
- a flocked sintered element;
- a foam covered in fibers that are formed of flocking of different lengths and/or of different shapes, i.e. a mixture of at least two kinds of flocking;
- 10 • a foam that includes fibers that are formed of burst foam cell walls; and/or
- portions in relief of height lying in the range 0.1 millimeters (mm) to 2 mm, which portions are not associated with the intrinsic structure of a material
- 15 defining the distal face.

The applicator member may present a distal face for contacting the skin, with a contact area of at least 0.5 square centimeters (cm²), better at least 1 cm². In preferred embodiments, the applicator member includes, in

20 at least one region of the distal face coming into contact with the skin, fibers that are formed of flocking of different lengths and/or of different shapes, or fibers that are formed of burst foam cell walls. The flocking may come from a mixture of flocking comprising

25 at least two kinds of flocking having respective mean lengths that are different.

The term "felt" signifies a non-woven structure comprising agglomerated fibers.

The term "sintered element" should be understood to

30 mean a ceramic or a metal sintered element or a material made from plastics material, e.g. by sintering grains made of plastics material, possibly elastomer.

The term "portion in relief that is not associated with the intrinsic structure of a material" should be

35 understood to mean a portion in relief other than the microrelief that is naturally present on the surface of said material. For example, when the material is a foam,

the portion in relief is other than the microrelief formed by the cells of the foam in the section plane of said material.

By means of the invention, with other things being equal and in the presence of vibration, the irregular surface thus created on the distal face enables the applicator member to slide over the skin more easily and to convey more composition. For a felt and for a sintered element, the surface on which the flocking is deposited is irregular because of the agglomeration of the particles of the sintered element or of the fibers of the felt.

A more uniform coverage of composition may be obtained.

The applicator member may comprise a foam, e.g. having cells that are open, half open, or closed, preferably made out of a material that is elastically deformable. US patent No. 7 083 351 B2 describes an applicator including fibers that are formed of burst foam cell walls. The term "foam" means a cellular material that may be obtained by foaming synthetic material, for example.

For example, the foam includes between 30 to 120 pores per inch (ppi), preferably between 30 to 90 pores per inch.

Preferably, the density of the foam lies in the range 1.5 to 3.5 pounds per cubic foot (lbs/cu.ft).

The thickness of the foam may be greater than 2 mm, or even greater than 5 mm. The distal face may generally be plane in its region for contacting the skin, in particular when including fibers as described above.

The distal face may include flocking having a length that lies in the range 0.1 mm to 0.5 mm, for example.

The distal face may include a mixture of flocking of different lengths, in particular short first flocking and longer second flocking, the difference between the respective mean lengths of the two kinds of flocking

being at least 0.5 mm, for example, better at least 1 mm, better still at least 2 mm. By way of example, the relative number proportions between two kinds of flocking lies in the range 30/70 to 70/30, e.g. 50/50.

5 On its distal face, the applicator member may include portions in relief that project by a distance lying in the range 0.1 mm to 2 mm, e.g. lying in the range 0.5 mm to 2 mm, relative to an adjacent recessed zone of the distal face. An irregular surface is thus
10 obtained that also favors sliding under the effect of vibration.

 The contact area of the distal face for contacting the skin while the device is being used may lie in the range 0.5 cm² to 15 cm², better in the range 1 cm² to
15 15 cm², better still in the range 3 cm² to 15 cm², preferably being greater than or equal to 5 cm², or even greater than or equal to 10 cm². The contact area is measured while the applicator member is pressing against the skin in order to obtain maximum contact.

20 The vibration source may be fastened in removable manner on the device. This makes it possible to use it on another device.

 In particular when it comprises a foam body, the applicator member may include an annular groove between
25 the distal face and the handle portion, and/or it may be internally hollow. This may impart more flexibility to the applicator member.

 The vibration source may be housed in the handle portion.

30 The handle portion may be fastened on a container when not in use, and it may be separable therefrom during use.

 Vibration may be oriented in various ways relative to the longitudinal axis X of the device, in particular
35 it may be oriented parallel to the longitudinal axis X or transversally relative thereto, e.g. perpendicularly to the longitudinal axis X, depending on the treatment being

performed and the kind of keratinous material being treated.

The distal face may extend perpendicularly to the longitudinal axis of the device. The distal face may be generally circularly symmetrical about the longitudinal axis.

Very satisfactory results are obtained when the vibration is parallel, at least in part, to the longitudinal axis of the device, and perpendicular to its distal face.

The device may include the composition for application, said composition being in liquid, powder, or solid form, e.g. a cream, a gel, a loose powder, a compacted powder, or a cast block.

The supply of composition may optionally be secured to the applicator member when said member comes into contact with keratinous material for applying the composition thereon. The composition may be a makeup or care product composition, e.g. a foundation.

When not in use, the applicator member may be received in a housing that contains the composition for application or that is separated from a reservoir containing the composition by a wall that is permeable to the composition and that is optionally permanently open. By way of example, the wall is a wall made of thermoplastic material having one or more composition delivery orifices passing therethrough. When the applicator member is received in the housing, it may optionally be in its compressed state. The housing may be supplied with composition by a pump or a valve, by composition flowing by gravity, or by composition being pressurized, e.g. by means of a piston or by reducing the internal volume of the reservoir containing the composition.

In exemplary embodiments, when not in use, the applicator member is received in a housing, and comes to bear at one end against a surface loaded with

composition. By way of example, the surface is defined by a face of a block of said composition, said composition being a compacted or molded powder, for example.

5 The invention can be better understood on reading the following detailed description of non-limiting embodiments thereof, and on examining the accompanying drawings, in which:

• Figure 1 is a diagrammatic view in elevation
10 showing an example of an applicator device made in accordance with the invention;

• Figures 2A to 2E show different possibilities, amongst others, for creating an application surface that is not smooth;

15 • Figures 3A and 3B show two examples, amongst others, of vibration sources that are suitable for being used; and

• Figures 4 to 12 show other examples of applicator devices made in accordance with the invention.

20 The applicator device 1 shown in Figure 1 includes an applicator member 2 that is secured to a handle portion 3 making it possible to manipulate the device so as to bring the distal face 5 of the applicator member into contact with the skin.

25 The handle portion 3 carries a vibration source 20 that, by way of example, is received in removable manner in a housing of the handle portion, so as to be able to be used on other applicator devices.

30 The handle portion 3 is connected at its base to a sole plate 9. The sole plate may support the applicator member 2, on its side opposite from the handle portion 3.

The applicator member 2 may comprise a body formed of a foam made of synthetic material.

35 A mounting skirt 10 that is connected to the sole plate 9 may define a housing for receiving the top portion 14 of the applicator member 2. Where appropriate, an annular groove 13 may be made between the

distal face 5 and the top portion 14, so as to impart more flexibility to the applicator member 2.

The vibration source 20 transmits its vibration to the distal face 5 while the device 1 is being used.

5 The device 1 may be used independently of a container containing the composition for application, or, in a variant, it may be arranged so as to be fastened, when not in use, on the container containing the composition for application, and, by way of example, it
10 may be configured to close said container in leaktight manner.

Vibration source

The vibration source is configured so as to generate
15 vibration, e.g. sinusoidal vibration, e.g. of frequency lying in the range 0.5 hertz (Hz) to 1000 Hz, or even in the range 1 Hz to 500 Hz, better in the range 10 Hz to 300 Hz, e.g. in the range 50 Hz to 200 Hz.

Vibration may be produced intermittently or
20 continuously.

The vibration source may include a vibration generator comprising a motor, e.g. a disk-shaped motor, driving an off-center fly-weight in rotation. The speed of rotation of the motor may lie in the range 2000
25 revolutions per minute (rpm) to 15000 rpm, e.g. lying in the range 4500 rpm to 10000 rpm.

The vibration generator may be of some other kind, e.g. piezoelectric, electromechanical, or eccentric. The vibration generator may also comprise a motor that
30 rotates a toothed wheel in contact with an elastically-deformable blade like a rattle.

The voltage used may lie in the range 1.5 volts (V) to 9 V, for example. The vibration source may include an electricity source, such as a 1.5 V button battery.

35 The use of a button battery may turn out to be advantageous for reducing the bulkiness of the device. When using a button battery and a disk-shaped motor, the

battery and the motor may be face-to-face, side-by-side, or the face of one may face the edge of the other.

The vibration source may include a control member for controlling its operation. The control member may be triggered by pressing it. The control member may be disposed in such a manner that it is pressed when the user takes hold of the device, in particular the container or the applicator. The control member may optionally present momentary contact, the operation of the vibration source ceasing as soon as the control member is released, for example.

The device may be configured so as to enable the vibration source to be actuated automatically when said vibration source is put into place on the remainder of the device. In a variant, actuation of the vibration source may be triggered by the user acting on a contactor while said vibration source is in place.

The vibration produced may be oriented substantially parallel to the longitudinal axis of the device. In a variant, the vibration may be oriented substantially perpendicularly to the longitudinal axis of the device. All or some of the vibration may be oriented perpendicularly to the distal face.

Where appropriate, the orientation of the vibration may be modified by changing the position of the vibration source. By way of example, the orientation of the motor relative to the applicator member may be modified when the vibration source is moved in its housing.

The vibration source may optionally be removable. As shown, the vibration source 20 may include a control surface 21, e.g. defined by a contactor that is triggered by pressing it.

On its side and starting from its proximal end, the handle portion 3 may present a slot 29 that passes a lever 41 defining the control surface 21.

As shown in Figures 3A and 3B, the casing 43 of the vibration source 20 may include a finger 25 or any other

projection capable of channeling vibration from the vibration source 20 towards the applicator member 2, the finger 25 coming into contact with the sole plate 9, for example, so as to transmit the vibration to the applicator member 2.

As can be seen in Figure 3A, the casing 43 of the vibration source 20 may be made with two half-shells 51 and 52 that are interconnected via a film hinge 54, or that are assembled together in some other way, e.g. the two half-shells 51 and 52 being molded as a single piece out of thermoplastic material, or, in a variant, out of another material, e.g. metal, providing care is taken to ensure that the casing does not create a short-circuit.

By way of example, the half-shell 51 carries the finger 25, while the other half-shell presents a semi-circular opening 56 that is adapted to engage on the finger 25 when the casing is closed. Assembly pins 60, e.g. two in number, are formed on one of the half-shells, e.g. the half-shell carrying the lever 41, and may engage in corresponding housings 62 of the other half-shell that are situated on the edge remote from the hinge 54, so as to hold the casing 43 in its closed position.

In the embodiment shown, the lever 41 is integrally molded with the half-shell 52.

When the casing 43 is closed, the user may press on the control surface 21 so as to make the electrical circuit connecting a battery 80 to a motor 70, thereby starting said motor. The motor 70 rotates a fly-weight having a center of inertia that is not situated on the axis of rotation.

The fly-weight may be situated inside the casing of the motor 70, as in the embodiment in Figure 3A, or it may be external to the motor, as in the embodiment in Figure 3B, and having the reference 71 in said figure.

The oscillations produced on the applicator member 2 may also encourage: sliding of the applicator member over the skin; organizing and/or anchoring the composition

being applied to the skin; or cleansing the skin when the composition exerts a cleansing action, e.g. with foam being generated.

When the device includes the vibration source 20 shown in Figure 3A, the vibration generated by the vibration source 20 is oriented longitudinally. In contrast, the vibration source shown in Figure 3B generates vibration that is oriented transversally relative to the longitudinal axis of the vibration source.

The frequency of the oscillation, its orientation, and its amplitude could be adapted to each type of application depending on the desired result, e.g. modifying the rheology of the composition, and/or improving the deposition of the composition or generally improving cleansing or the application of makeup.

The vibration source may be proposed to the user pre-mounted on the container or on the applicator within a package, e.g. a presentation case, a bag, a blister pack, a box. In a variant, the vibration source may be in the non-assembled state together with the applicator or the container within the package. The vibration source may be proposed with at least two different containers or two different applicator members within a single package.

In exemplary embodiments of the invention, the distal face 5 presents a surface that is not smooth, so as to facilitate sliding of the device 1 over the skin, while the composition is being applied, under the effect of vibration generated by the vibration source 20.

By way of example, the non-smooth surface may cover all of the distal face 5 of the applicator member 2, as shown in Figure 1, and in particular it may extend over at least a fraction of the side surface 12 of the applicator member 2.

The non-smooth surface may be obtained in various ways, e.g. by a mixture of flocking, as shown in Figures 1 and 2A.

5 Mixture of flocking

The flocking may be non-uniform. In these exemplary embodiments of the invention, the flocking is constituted by different kinds of fibers, e.g. fibers of shapes and/or dimensions that are different. The difference in
10 shape and/or the difference in length makes it possible to create interstices making the distal face irregular.

In particular, the mixture may include fibers of different lengths, diameters, and/or sections. The term "diameter" should be understood to mean the diameter of
15 the circle when the section is circular, or else the diameter of the circle that circumscribes the section when it is not circular.

The fibers are selected from fibers of length lying in the range 0.02 mm to 3 mm, for example, and of
20 diameter lying in the range 0.01 mm to 0.6 mm, for example. The fibers may have a cross-section that is: circular; oval; polygonal; cross-shaped; three-lobed; four-lobed; C, E, F, H, I, L, N, S, T, V, W, X, Y, or Z shaped; star shaped; or crescent shaped. The fibers may
25 be made of: polyamide, e.g. nylon®; polyacrylic; polyester; cotton; or cellulose, e.g. viscose or rayon. The fibers may be selected from fibers of any color.

The mixture of flocking may comprise straight fibers and curved fibers.

30 The fibers may be treated or may include additives such as for example: slip additives; absorbent agents; anti-UV agents; magnetic or magnetizable particles; bactericidal agents; etc...

In an implementation of the invention, the distal
35 face 5 is covered by a flocked coating that is constituted by a mixture of two different kinds of flocking 19a and 19b, e.g. with about 75% by weight of

the first type of fibers, e.g. the longer flocking 19a, and about 25% by weight of the second type of fibers. By way of example, the fibers 19a are rayon fibers and have a length of about 1.2 mm and a diameter of about 0.1 mm.

5 By way of example, the fibers 19b are polyester fibers and have a length of about 0.5 mm and a diameter of about 0.2 mm. The shorter fibers of greater diameter 19b make it possible to space apart the fibers of smaller diameter 19a and leave gaps between them. Spaces are thus
10 obtained between the short fibers and the longer fibers.

In other exemplary embodiments, the distal face 5 is covered by a coating formed by a mixture of polyamide fibers of 0.5 mm in length and of 1.7 decitex (dtex) in diameter, and of polyamide fibers of 1.3 mm in length and
15 of 2/100 dtex in diameter.

In other exemplary embodiments, the flocked coating comprises two type of fibers of circular section, the two types of fibers having the same length, e.g. approximately equal to 1 mm, and the same diameter, e.g. approximately equal to 0.1 mm. The fibers of the first
20 flocking may be made of cotton and curved, and the fibers of the second flocking may be made of polyester and straight. By way of example, the mixture may comprise 25% by weight of curved fibers and 75% by weight of
25 straight fibers. Thus, the surface of the flocked coating includes relief irregularities in relief resulting from the presence of spaces formed between the straight fibers and the curved fibers.

The above examples relate to mixtures of two types
30 of fiber. The flocked coating may be obtained by mixing together a greater number of types of fiber, in particular as a function of the desired result.

Furthermore, the surface of the applicator member may be covered in various mixtures of different types.

35 The flocking used may be of any type, including natural types. The flocking may be magnetizable and/or electrically conductive.

In other exemplary embodiments of the invention, the flocking may be uniform, i.e. constituted by fibers that are all identical.

The applicator member may include a uniform surface
5 that is covered by flocking that is not uniform, or, in other exemplary embodiments, a non-uniform surface, e.g. a foam including portions in relief, and covered by flocking that is uniform.

10 Burst cells

The non-smooth surface of the distal face of the applicator member may also be obtained by treating a foam that is used to make the body of the applicator member, as shown in diagrammatic manner in Figure 2B.

15 In these exemplary embodiments, the fibers are formed out of the same material as the portion of the applicator member to which they are connected.

The term "fiber" should be understood in a broad sense and encompasses structures that might not be
20 totally filamentary, e.g. presenting one or more free ends and one or more zones, e.g. two or three zones, that are connected to the remainder of the applicator member. A fiber may thus include branches, for example. A fiber may include one or more filamentary extensions having
25 free ends, and it may be connected in flexible manner to the remainder of the applicator member.

In its surface, the foam may have craters that may, for example, have a depth that is greater than or equal to 0.4 mm, possibly greater than or equal to 0.7 mm, e.g.
30 greater than or equal to 1.3 mm, or even greater than or equal to 1.5 mm.

Such craters may be obtained by removing the walls of a group of cells, said group comprising between 5 to 15 cells, for example.

35 The fibers may extend around each crater.

The foam may comprise a network of filamentary walls, e.g. being made out of a material selected from

the following list: polyurethane, polyether, polyester, polyvinyl chloride, ethyl vinyl acetate (EVA), this list not being limiting. The foam may present hydrophilic properties, in particular it may incorporate at least one
5 water-absorbent compound, e.g. a polyacrylate.

When the foam presents hydrophilic properties and possibly contains water-absorbent compounds, the fact that the foam presents a surface state as defined above may further enhance its affinity for compositions
10 containing water.

For a majority of the fibers for example, the distance measured between a free end of the fiber and an end for connecting to the remainder of the applicator member (i.e. the unaltered structure), may be greater
15 than the mean length of a wall of a cell.

By way of example, the depth of a crater may be determined by an optical method as described in US 7 083 351 B2, which method consists in using a microscope, firstly to focus on the walls bordering the
20 crater, and secondly to focus on the walls that constitute the bottom of the crater, and then to take a reading relating to the movement of the microscope therebetween.

Using this method, it is possible to measure a mean
25 crater depth that may be greater than 0.7 mm, for example.

The number and the depth of the above-mentioned craters and the length of the fibers formed depends on the abrasive treatment to be performed, and in particular
30 on the pressure exerted on the foam during abrasion, and on the surface state of the tool that is used to treat the foam, e.g. its roughness. Reference can usefully be made to US patent No. 7 083 351 B1, the contents of which are incorporated herein by reference.

35 By way of example, the depth of the craters may thus be deeper or shallower, e.g. lying in the range about 0.4 mm to about 2 mm.

The fibers created by the abrasion may extend substantially around each crater.

Portions in relief

5 The non-smooth surface of the distal face of the applicator member may also be obtained by means of portions in relief that are formed at the surface of the applicator member, on the distal face 5, e.g. portions in relief such as those shown in Figures 2C and 2D
10 comprising a succession of hollows 16 and beads 17 that may present any shape, e.g. the shape of studs or ribs, said beads possibly being rectilinear, annular, or criss-crossed, for example, amongst other possibilities.

 The shape of a bead 17 may be flat, as shown in
15 Figure 2C, or rounded or even tapered, as shown in Figure 2D.

 The vertex of a bead 17 may project by a distance \underline{d} , e.g. lying in the range 0.1 mm to 2 mm, relative to the adjacent recessed zone. The distance \underline{d} may be
20 substantially the same for all of the hollows and beads of the distal face 5, or, in a variant, may vary as a function of the position on the distal face 5.

 Where appropriate, as shown in Figure 2E, the portions in relief 17 formed on the distal face 5 may be
25 flocked, and not necessarily by a mixture of flocking, e.g. by uniform flocking, so that the envelope surface defined by the free ends of the fibers of the flocking follows the outline of the underlying portions in relief.

30 Other examples of devices

 The device 100 shown in Figure 4 includes a container 110 containing the composition for application. The applicator member 2 is mounted in removable manner on the container 110, being received in a housing 112 when
35 not in use. The applicator member 2 may be supplied with composition via a hollow rod 115 of a pump or a valve that may be actuated by moving a head 120 carrying the

device 1, relative to the container 110. By way of example, the composition is dispensed in the bottom of the housing 112, at the center of the distal face 5.

In the variant in Figure 5, when not in use, the device 1 may be mounted on the container 110 containing the composition.

The applicator member 2 is received in a housing 132 into which no composition supply orifice opens out. By way of example, the housing 132 is defined by a cap 140 that is suitable for being fastened on the container 110, e.g. screw-fastened or snap-fastened on a neck 143 of the container. By way of example, the container 110 is fitted with a pushbutton 146 for dispensing the composition onto the surface to be treated.

As shown in Figure 6, when not in use, the device 1 may close the container 110 containing the composition P.

In these exemplary embodiments, the applicator member 2 is received in a housing 112 that is separated from a reservoir 150 containing the composition P, by a perforated wall 153. The distal face 5 may optionally come to bear against the wall 153.

Figure 7 shows the possibility of packaging the device 1 and the composition P separately within a box 160. By way of example, a plurality of different compositions P are contained in respective dishes 161.

The device in Figure 8 differs from the device in Figure 5 by the fact that the cap 140 is configured so as to close a dispenser endpiece 163 of the container 110.

In the embodiment in Figure 9, the applicator member 2 is secured to the container during application.

By way of example, the vibration source 20 is received in a housing of the container 110, which housing is situated remote from the applicator member 2. By way of example, the applicator member is a flocked membrane having one or more composition supply orifices passing therethrough.

The invention is not limited to the embodiments shown. The foam applicator member may be replaced by a membrane that is impermeable to the composition, said membrane having a surface defining the distal face 5 that may be flocked with a mixture of flocking, as shown in Figure 10, and/or that may be provided with portions in relief.

The foam may be replaced by a flocked sintered element or by a flocked felt, as shown in Figures 11 and 12.

In Figure 11, the applicator member is constituted by a flocked sintered element, e.g. a sintered element made of polyethylene (PE).

In Figure 12, the applicator member is constituted by a flocked felt.

The expression "comprising a" should be understood as being synonymous with "comprising at least one" unless specified to the contrary.

Comparative tests have been performed with a flocked and non-flocked foam. The table below gives the characteristics of such a foam before flocking.

The comparative tests demonstrate that sliding was improved considerably with a flocked foam.

	Value	Method
Foam grade	CF-88	
Color	Skin tone	
Cell count (pores per inch)	47.5 ± 7.5 ppi	
Reticulation	Not reticulated	
Density	2.5 ± 0.25 pounds per cubic foot (lbs/cu.ft.)	ASTM D 3574-91
25% CFD	1.8 ± 0.18	ASTM D 3574-91
Compression set @ 50% deflection	15% maximum	ASTM D 3574-91
Autoclave loss		

Tensile strength	17 pounds per square inch (psi) minimum	ASTM D 3574
Elongation @ break	100% minimum	ASTM D 3574
Resilience	40% minimum	FMVSS-302
Volume swell in water	< 40%	
Germicide	None	
Holes	One 1 mm maximum diameter hole per 2 × 2 blank. No more than two holes per blank of any size	

CLAIMS

1. An applicator device (1) for applying a composition to the skin, the device comprising:
- a vibration source (20);
 - 5 • a handle portion (3); and
 - an applicator member (2) that is secured to the handle portion, at least during application;
- the applicator member presenting a distal face (5) for contacting the skin, the applicator member (2) including, in at least one region of the distal face
- 10 (5) that comes into contact with the skin:
- a flocked felt;
 - a flocked sintered element;
 - a foam covered in fibers that are formed of flocking of different lengths and/or of different
- 15 shapes;
- a foam that includes fibers that are formed of burst foam cell walls; and/or
 - portions in relief (16, 17) of height lying in the
- 20 range 0.1 mm to 2 mm, which portions are not associated with the intrinsic structure of a material defining the distal face.
2. A device according to claim 1, the applicator member including a foam of thickness that is greater than
- 25 2 mm, better greater than 5 mm.
3. A device according to claim 1, the applicator member including a membrane that carries said portions in
- 30 relief.
4. A device according to any one of claims 1 to 3, the distal face (5) generally being plane in its region for contacting the skin.
- 35
5. A device according to any preceding claim, the distal face (5) including a mixture of flocking of different

lengths, in particular with a difference of respective mean lengths of at least 0.5 mm, better at least 1 mm.

- 5 6. A device according to claim 2, including said portions in relief (17).
- 10 7. A device according to any preceding claim, the contact area of the distal face for contacting the skin while the device is being used lying in the range 0.5 cm² to 15 cm², better in the range 1 cm² to 15 cm², better still in the range 3 cm² to 15 cm².
- 15 8. A device according to any preceding claim, the vibration source (20) being fastened in removable manner on the device.
- 20 9. A device according to any preceding claim, including the composition (P) for application.
- 20 10. A device according to any preceding claim, the applicator member (2) including an annular groove (13) between the distal face (5) and the handle portion (3), and/or being internally hollow.
- 25 11. A device according to any one of claims 1 to 10, the vibration source (20) being housed in the handle portion (3).
- 30 12. A device according to any one of claims 1 to 11, the handle portion being suitable, when not in use, for fastening on a container containing the composition, and being separable therefrom during use.
- 35 13. A device according to any one of claims 1 to 11, the vibration source (20) being secured to a container containing the composition, while the applicator member is being used.

Fig.1

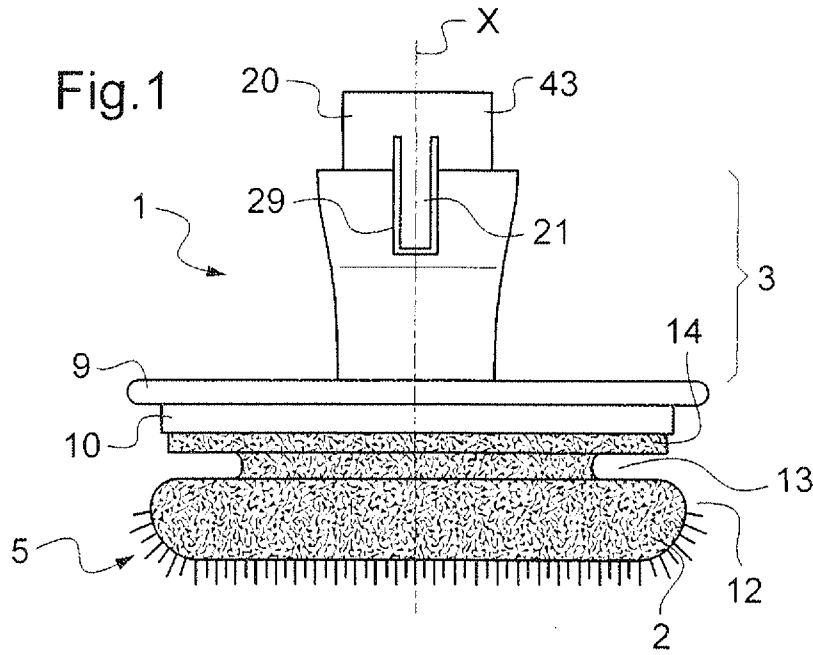

Fig.2A

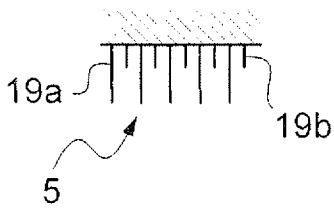

Fig.2B

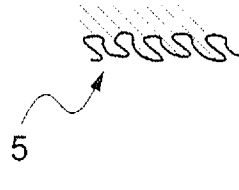

Fig.2C

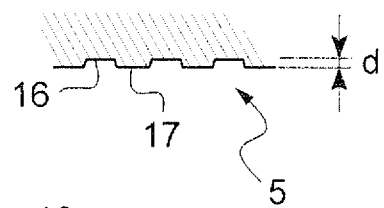

Fig.2B

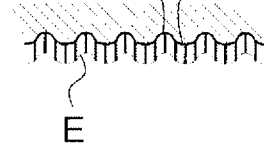
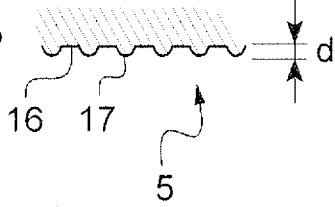

Fig.2B

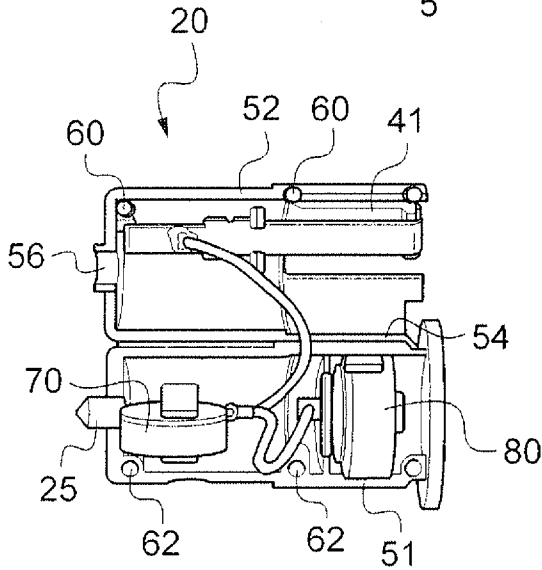

Fig.3A

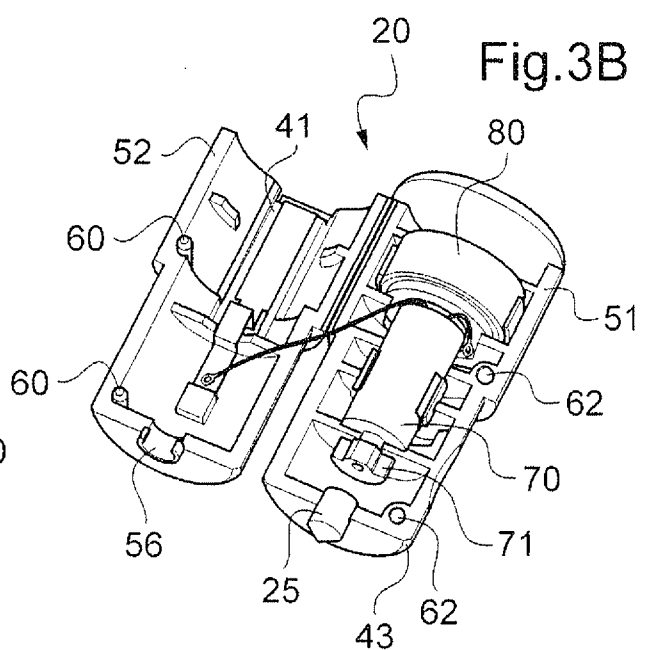

Fig.3B

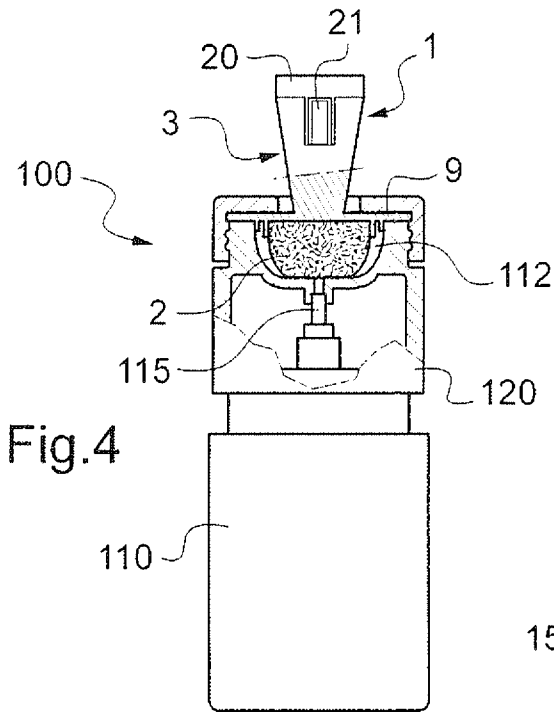

Fig. 4

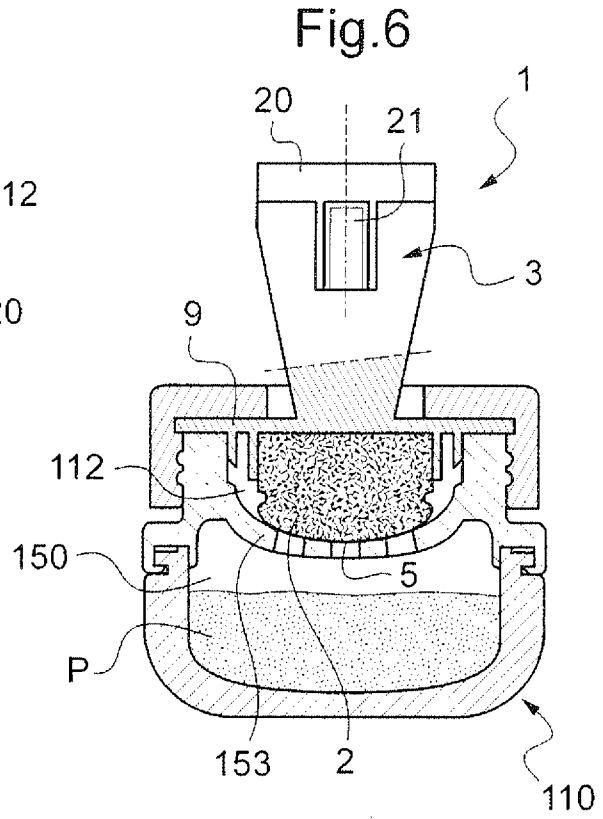

Fig. 6

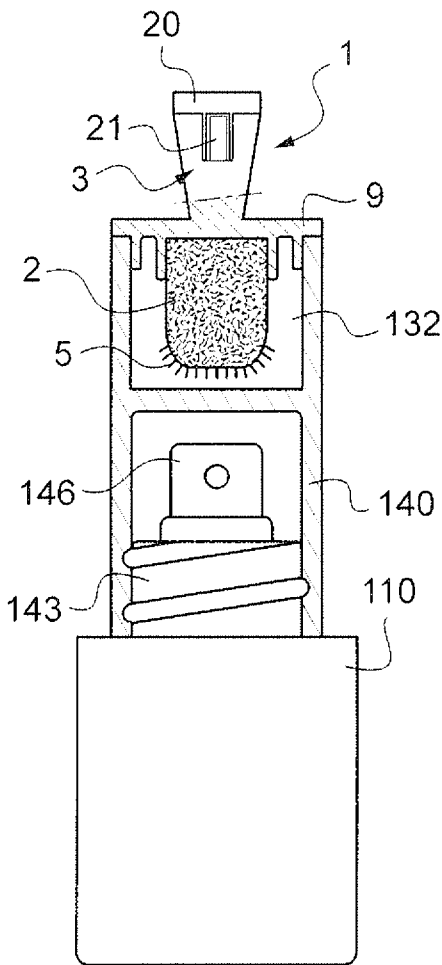

Fig. 5

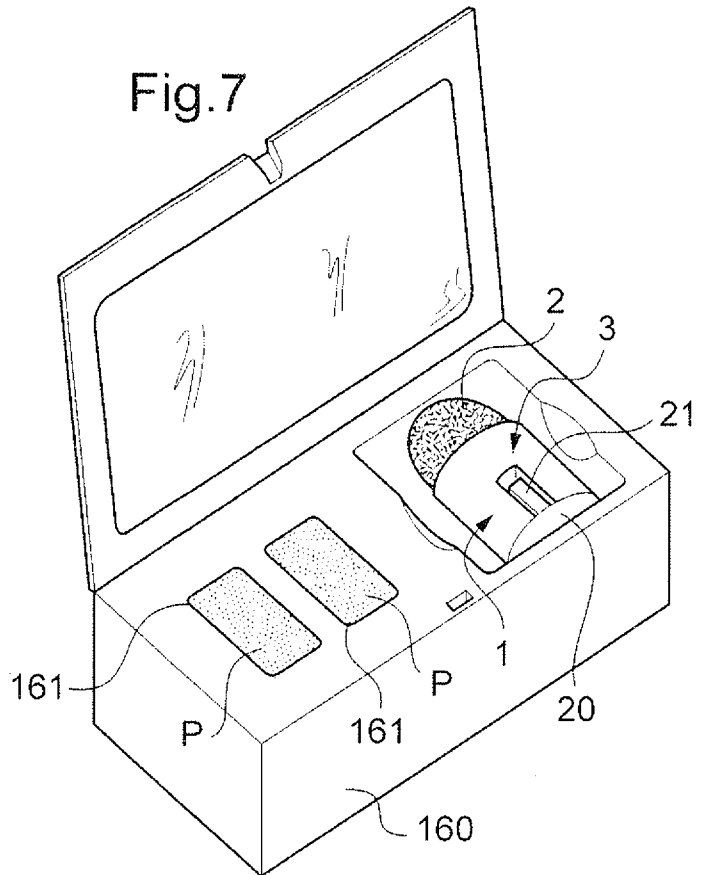
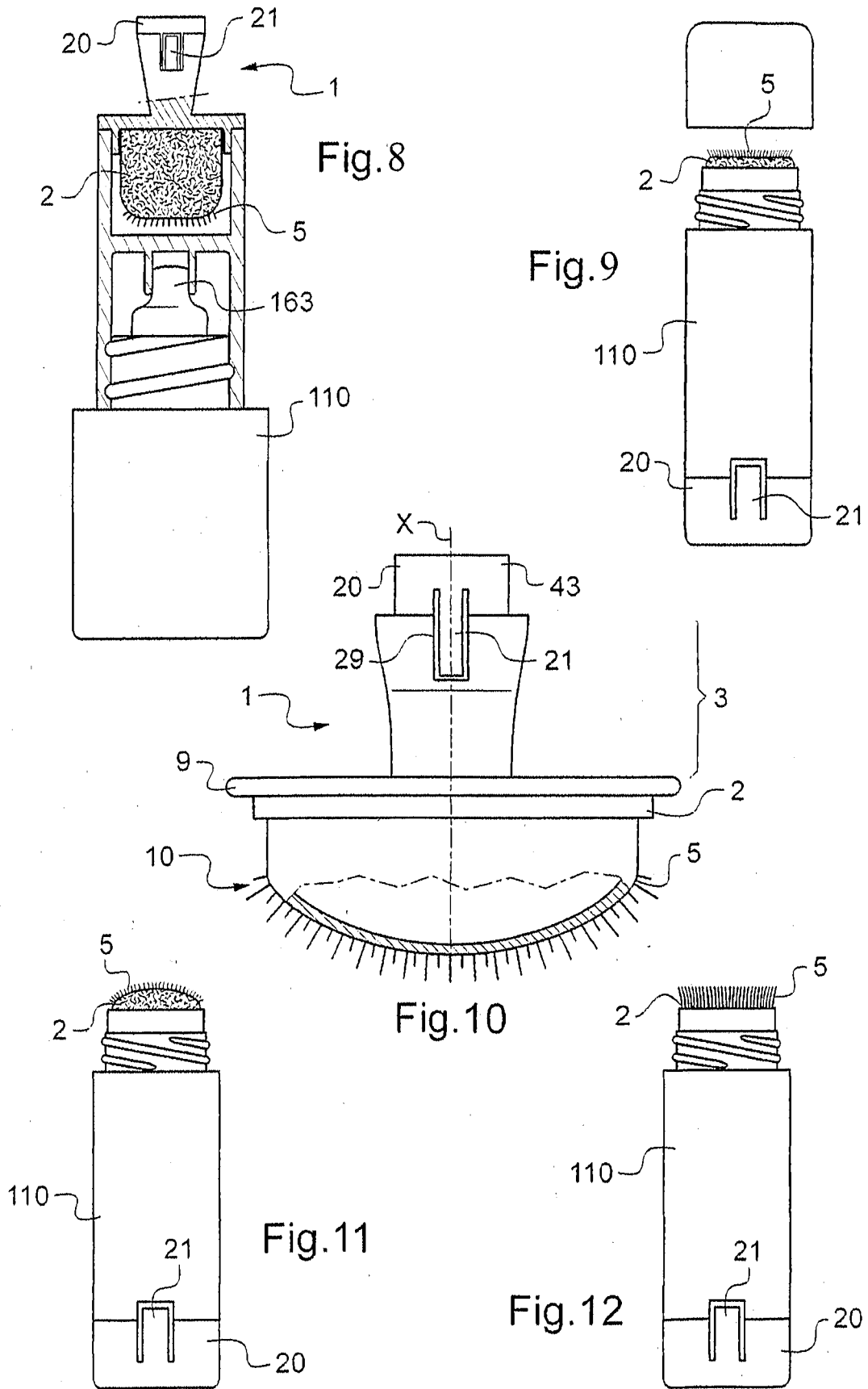

Fig. 7



INTERNATIONAL SEARCH REPORT

International application No
PCT/IB2010/051062

A. CLASSIFICATION OF SUBJECT MATTER
INV. A45D34/04 A45D40/26
ADD.

According to International Patent Classification (IPC) or to both national classification and IPC

B. FIELDS SEARCHED

Minimum documentation searched (classification system followed by classification symbols)
A45D

Documentation searched other than minimum documentation to the extent that such documents are included in the fields searched

Electronic data base consulted during the international search (name of data base and, where practical, search terms used)
EPO-Internal, WPI Data

C. DOCUMENTS CONSIDERED TO BE RELEVANT

Category*	Citation of document, with indication, where appropriate, of the relevant passages	Relevant to claim No.
X	GB 846 639 A (ANTIONE FRANCOIS REGIS PEYRON) 31 August 1960 (1960-08-31) page 1, line 8 - line 59 page 2, line 43 - line 62 page 5, line 99 - page 6, line 28; claims; figures	1-13
X	WO 2007/138287 A2 (BALL BURNISHING MACH- TOOLS [GB]; LINZELL GEOFFREY ROBERT [GB]) 6 December 2007 (2007-12-06) page 1, paragraph 2 page 8, paragraph 4 - page 10, paragraph 6 page 12, paragraph 2 page 14, paragraph 3 - paragraph 4; claims; figures	1-13

Further documents are listed in the continuation of Box C.

See patent family annex.

* Special categories of cited documents :

- "A" document defining the general state of the art which is not considered to be of particular relevance
- "E" earlier document but published on or after the international filing date
- "L" document which may throw doubts on priority claim(s) or which is cited to establish the publication date of another citation or other special reason (as specified)
- "O" document referring to an oral disclosure, use, exhibition or other means
- "P" document published prior to the international filing date but later than the priority date claimed

- "T" later document published after the international filing date or priority date and not in conflict with the application but cited to understand the principle or theory underlying the invention
- "X" document of particular relevance; the claimed invention cannot be considered novel or cannot be considered to involve an inventive step when the document is taken alone
- "Y" document of particular relevance; the claimed invention cannot be considered to involve an inventive step when the document is combined with one or more other such documents, such combination being obvious to a person skilled in the art.
- "&" document member of the same patent family

Date of the actual completion of the international search

15 June 2010

Date of mailing of the international search report

24/06/2010

Name and mailing address of the ISA/

European Patent Office, P.B. 5818 Patentlaan 2
NL - 2280 HV Rijswijk
Tel. (+31-70) 340-2040,
Fax: (+31-70) 340-3016

Authorized officer

Acerbis, Giorgio

INTERNATIONAL SEARCH REPORT

International application No
PCT/IB2010/051062

C(Continuation). DOCUMENTS CONSIDERED TO BE RELEVANT

Category*	Citation of document, with indication, where appropriate, of the relevant passages	Relevant to claim No.
Y	US 2004/047673 A1 (GUERET JEAN-LOUIS [FR]) 11 March 2004 (2004-03-11) paragraphs [0001], [0004], [0007], [0012], [0013], [0017], [0029]; claims; figures 1,14-16 -----	1-13
Y	US 7 481 592 B2 (GUERET JEAN-LOUIS [FR]) 27 January 2009 (2009-01-27) cited in the application column 2, line 39 - line 53; claims; figures -----	1-13

INTERNATIONAL SEARCH REPORT

Information on patent family members

International application No
PCT/IB2010/051062

Patent document cited in search report	Publication date	Patent family member(s)	Publication date
GB 846639	A	31-08-1960	
		BE 569995 A	14-07-1961
		CH 351374 A	15-01-1961
		DE 1078296 B	24-03-1960
		FR 73607 E	05-09-1960
<hr/>			
WO 2007138287	A2	06-12-2007	
		WO 2007138280 A2	06-12-2007
<hr/>			
US 2004047673	A1	11-03-2004	NONE
<hr/>			
US 7481592	B2	27-01-2009	
		EP 1858366 A1	28-11-2007
		FR 2882506 A1	01-09-2006
		WO 2006090343 A1	31-08-2006
		US 2009071501 A1	19-03-2009
		US 2008138138 A1	12-06-2008