

(19) World Intellectual Property Organization
International Bureau



(43) International Publication Date
21 February 2008 (21.02.2008)

PCT

(10) International Publication Number
WO 2008/021934 A2

(51) International Patent Classification:
F16L 21/00 (2006.01)

(21) International Application Number:
PCT/US2007/075551

(22) International Filing Date: 9 August 2007 (09.08.2007)

(25) Filing Language: English

(26) Publication Language: English

(30) Priority Data:
11/502,075 10 August 2006 (10.08.2006) US

(71) Applicant (for all designated States except US): **WEBER-STEPHEN PRODUCTS CO.** [US/US]; 200 E. Daniels Road, Palatine, IL 60067 (US).

(72) Inventor (for US only): **ZELEK, Leonard**; 3650 N. Sawyer Avenue, Chicago, IL 60618 (US).

(74) Agent: **ROCHE, David, I.**; Baker & Mckenzie Llp, 130 E. Randolph Drive, Chicago, IL 60601 (US).

(81) Designated States (unless otherwise indicated, for every kind of national protection available): AE, AG, AL, AM, AT, AU, AZ, BA, BB, BG, BH, BR, BW, BY, BZ, CA, CH, CN, CO, CR, CU, CZ, DE, DK, DM, DO, DZ, EC, EE, EG, ES, FI, GB, GD, GE, GH, GM, GT, HN, HR, HU, ID, IL, IN, IS, JP, KE, KG, KM, KN, KP, KR, KZ, LA, LC, LK, LR, LS, LT, LU, LY, MA, MD, ME, MG, MK, MN, MW, MX, MY, MZ, NA, NG, NI, NO, NZ, OM, PG, PH, PL, PT, RO, RS, RU, SC, SD, SE, SG, SK, SL, SM, SV, SY, TJ, TM, TN, TR, TT, TZ, UA, UG, US, UZ, VC, VN, ZA, ZM, ZW.

(84) Designated States (unless otherwise indicated, for every kind of regional protection available): ARIPO (BW, GH, GM, KE, LS, MW, MZ, NA, SD, SL, SZ, TZ, UG, ZM, ZW), Eurasian (AM, AZ, BY, KG, KZ, MD, RU, TJ, TM), European (AT, BE, BG, CH, CY, CZ, DE, DK, EE, ES, FI, FR, GB, GR, HU, IE, IS, IT, LT, LU, LV, MC, MT, NL, PL, PT, RO, SE, SI, SK, TR), OAPI (BF, BJ, CF, CG, CI, CM, GA, GN, GQ, GW, ML, MR, NE, SN, TD, TG).

Published:
— without international search report and to be republished upon receipt of that report

(54) Title: BAYONET CONNECTION

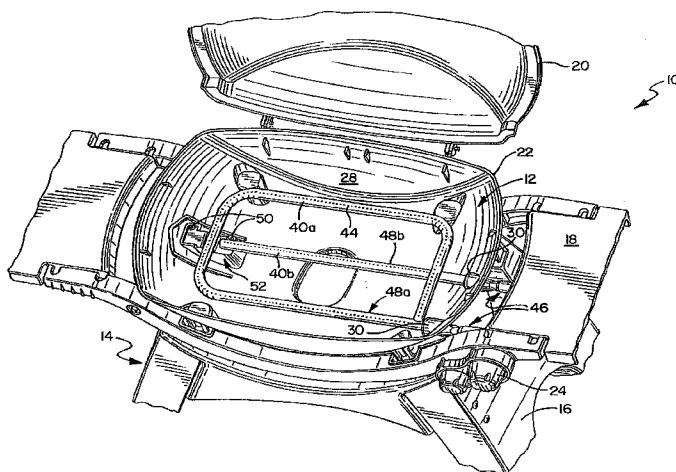

(57) Abstract: The inventions disclosed herein relate to a quick-connect fitting for connecting a burner tube to a barbecue grill. It is believed that the preferred quick-connect of the present invention reduces the time required to assemble a barbecue grill by providing for a simple two step assembly. The quick-connect generally comprises a female connector and a male connector wherein the female connector is preferably attached to the burner tube and the male connector is preferably connected upstream of the fuel supply. The female connector preferably has an inwardly directed protrusion while the male connector has a corresponding longitudinal entry portion and circumferential groove. In the first step of assembly, the female connector is mated with the male connector by aligning the protrusion with the entry portion and urging the connectors together. In the second step of assembly, the female connector is rotated relative to the male connector such that the protrusion enters the groove to effectively prevent relative axial movement between the connectors.



WO 2008/021934 A2

APPLICATION
FOR
UNITED STATES PATENT

TO ALL WHOM IT MAY CONCERN:

Be it known that I

Leonard ZELEK

have invented a

BAYONET CONNECTION FOR BURNER TUBE

of which the following is a description.

TITLE

BAYONET CONNECTION FOR BURNER TUBE

BACKGROUND AND SUMMARY OF THE INVENTIONS

5 The inventions described and claimed herein relate generally to gas burner tubes for
barbecue grills. More specifically, the inventions relate to quick-connects for connecting a
barbecue grill burner tube downstream from a gas supply. In particular, the preferred
embodiment of the quick-connect can be characterized as an improved version of a bayonet
connection which is less expensive to manufacture than traditional bayonet connections and
10 allows easier, faster, and more efficient installation of a gas burner tube in a barbecue grill.

The preferred embodiment of the present inventions is comprised generally of a female
connector and a male connector which are adapted to mate. The female connector and the male
connector are preferably cylindrical to allow one to be rotated relative to the other when in
mating configuration. The male connector is preferably integral with the gas supply control
15 valve (i.e. typically formed or attached to the downstream distal end of a gas supply tube) and
the female connector is preferably integral with the burner tube (i.e. typically formed or attached
to the upstream distal end of the burner tube). It is contemplated, however, that the male
connector could be integral with the burner tube and the female connector could be integral with
the gas supply control valve.

20 The female connector is preferably cylindrical and preferably has an inwardly directed
protrusion which is adapted to engage with the male connector and to lock the female connector

to the male connector. The protrusion can be formed by any means known in the art; but is preferably formed by punching the wall of the female connector to form an inwardly directed bridge. The male connector comprises an entry portion and a groove. The entry portion is preferably adapted to allow the male connector to mate with the female connector and is characterized as a pathway for receiving the protrusion into the groove. The entry portion is preferably longitudinally aligned but could be both circumferentially and longitudinally aligned (i.e. spiral). The groove is preferably aligned circumferentially and extends for at least a portion of the circumference of the male connector, although the groove preferably extends for the entire circumference of the male connector. As an alternative, the groove could be characterized as a detent. Even further, the groove could terminate in a detent. When the female connector is rotated relative to the male connector while in mating engagement, the groove receives the protrusion which effectively prevents the female connector from moving axially relative to the male connector. A tight fit is preferable, although there may be some play in the connection. It is contemplated that instead of the aforementioned configuration, the male connector could comprise an outwardly directed protrusion and the female connector could comprise the entry portion and groove.

The preferred embodiment of the present inventions is characterized by a simple two move assembly; i.e., the preferred embodiment of the quick-connect fitting provides a means for installing burner tubes in a barbecue grill with two simple steps, reducing the time and cost of assembling a barbecue grill. In the first step, the burner tube is placed into assembly orientation and pushed axially such that the female connector and male connector are urged into mating

engagement. In the assembly orientation, the protrusion on the female connector is aligned with the entry portion on the male connector, such that the female connector can receive the male connector. In the second step, the female connector is rotated into working orientation, wherein the protrusion is received into the groove, effectively preventing the female connector from axially disengaging the male connector. In the working orientation, the orifices on the burner tube are properly aligned for operation, preferably in the upward direction.

BRIEF DESCRIPTION OF THE DRAWINGS

These and other features, aspects, objects, and advantages of the inventions described and claimed herein will become better understood upon consideration of the following detailed description, appended claims, and accompanying drawings where:

Figure 1 is a perspective view of an exemplary barbecue grill with a preferred embodiment of the burner tube quick-connect;

Figure 2 is a rear partial sectional view of a preferred embodiment of the burner tube quick-connect with one burner tube in assembly orientation prior to mating engagement of the female connector with the male connector and another burner tube in working orientation;

Figure 3 is a right side view of a burner tube (in the assembly orientation) which is integral with a preferred embodiment of the female connector;

Figure 4 is a left side view of a preferred embodiment of the male connector; and

Figure 5 is a rear partial sectional view of a preferred embodiment of the burner tube quick-connect with a burner tube in working orientation.

It should be understood that the drawings are not necessarily to scale and that the

embodiments are sometimes illustrated by graphic symbols, phantom lines, diagrammatic representations and fragmentary views. In certain instances, details which are not necessary for an understanding of the inventions described and claimed herein or which render other details difficult to perceive may have been omitted. It should be understood, of course, that the inventions described herein are not necessarily limited to the particular embodiments illustrated herein.

Like reference numerals will be used to refer to like or similar parts from Figure to Figure in the following description of the drawings.

DETAILED DESCRIPTION OF THE DRAWINGS

Several of the figures attached hereto and the description below depict and/or discuss the connections of the present invention with reference to a P-shaped tube 40a. Nevertheless, it is contemplated that the connection (or quick-connect fitting) of the present invention could be used with a straight tube 40b or any other shaped tube (not shown).

Referring first to Figure 1, a barbecue grill 10 is depicted which includes a preferred embodiment of the present invention. The barbecue grill 10 is generally comprised of a cooking chamber 12 and a frame 14. In the particular style of grill shown in Figure 1, the frame 14 has side shelves 18 and is adapted to engage with a grill cart 16. The cooking chamber 12 as shown is comprised of a lower member 22 and an upper member 20, the upper member 20 being typically hingedly connected to the lower member 22. The present inventions are preferably directed to gas barbecue grills 10, which are typically fueled by either natural gas or liquefied propane gas ("LPG").

Fuel is typically directed to the cooking chamber 12 through a series of tubes 26, valves 24,

and regulators (not shown). The fuel is ultimately directed through these components to a gas burner tube 40a, 40b which is housed in the cooking chamber 12, but often extends through an opening 30 in the wall 28 of the lower member 22 to an exterior of the cooking chamber 12. It is at this point that the burner tube 40a, 40b is connected to a fuel supply tube 26.

5 The burner tubes 40a and 40b, having a plurality of orifices or ports 44, serve to distribute the fuel source in a generally even manner in the cooking chamber. As shown in Figure 1, when the burner tubes are installed properly, the orifices 44 are preferably upwardly directed, although the orifices 44 are not required to be directed as such.

 There are two general shapes of burner tubes 40a, 40b which are discussed herein with
10 reference to the present invention. However, it is contemplated that the present invention can be utilized with other shapes of burner tubes. The first is a "P" shaped burner tube 40a ("P-tube") and the second is a straight burner tube 40b ("straight tube"). Both the P-tube 40a and the straight tube 40b have first portions 46 and second portions 48a, 48b. The first portions 46 are adapted to extend
15 through an opening 30 in the wall 28 of the lower member 22, for connecting to the fuel supply lines. The second portions 48a, 48b are provided with orifices 44 from which flames emanate when the fuel source is ignited. The second portion 48a of the P-tube 40a is characterized as a loop while the second portion 48b of the straight tube 40b is straight. The burner tubes 40a, 40b, as depicted, each include a bracket 50 which extends from the second portion 48a, 48b for securing the burner tubes 40a, 40b, to the lower member 22.

20

 With reference to Figure 2, the connection of the present invention generally comprises a

male connector 60 and a female connector 80. In this Figure, both a P-tube 40a and a straight tube 40b are depicted, both of which have a female connector 80. However, the P-tube 40a is depicted in assembly orientation whereas the straight tube 40b is depicted in working orientation.

5 For both of the tubes 40a, 40b, the corresponding male connector 60 is connected to a tube 26 downstream of the control valve 24 and the female connector 80 is integral with the burner tube 40a, 40b and forms a part of the first portion 46 of the tube 40a. When installed on the grill 10, the male connector 60 is preferably aligned with an opening 30 in a side wall 28 of the lower member 22. It is contemplated that the female connector 80 could be an independent
10 component that is attached to the burner tube 40a, 40b by any appropriate fastening means or could be formed into a distal end of the burner tube 40a, 40b. Also, as discussed above, it is contemplated that the female connector 80 could be connected to the supply tubing 26 and the male connector could be connected to the burner tube 40a.

As better shown in Figure 3, the female connector 80 is preferably comprised of a tubular
15 member having an inwardly directed protrusion 82. The protrusion 82 can be formed by any means known in the art, such as by welding a protrusion 82 to the inside of the female connector 80. However, the protrusion 82 is preferably mechanically formed into the female connector 80 by a punching means. In this manner, an inwardly directed, chordal bridge is formed, as depicted. The protrusion 82 is preferably circumferential in orientation and is formed by two
20 circumferential slits 84. During the forming process, the material between the two slits 84 is preferably forced inwardly into a triangular shape, wherein the apex 86 of the protrusion 82 is

adapted to project into the groove 64 of the male connector 60 when the burner tube is in the working orientation. The apex 86 of the protrusion 82 is also dimensioned such that it can be received into the entry portion 62 of the male connector 60, as best shown in Figure 4.

The male connector 60 is comprised of a generally cylindrical body, wherein an entry
5 portion 62 and a groove 64 are formed into the generally cylindrical body. It is contemplated that under certain conditions, the male connector 60 may not be visible to the assembler during installation of the burner tube 40a. Consequently, the male connector 60 preferably comprises a chamfered leading edge 72 to facilitate the blind alignment of the female connector 80 with the male connector 60. It is believed that the chamfered front edge will further reduce the time
10 required to assemble the grill 10.

The entry portion 62 of the male connector 60 can be characterized as a flat surface 66 which is formed along a chord line. Alternatively, the entry portion 62 can be embodied as a channel. The entry portion 62 is generally axially oriented to allow the female connector 80 to mate with the male connector 60. The entry portion 62 of the male connector 60 is
15 interconnected with and preferably terminates at the groove 64 such that the protrusion 82 of the female connector 80 can be received by the groove 64 when the female connector 80 and the male connector 60 are in mating configuration, as is best shown in Figure 5.

The groove 64 is preferably characterized as a circumferential channel. The groove 64 preferably extends for the entire circumference of the male connector 60, although it is
20 contemplated that the groove 64 can extend for only a portion of the circumference of the male connector 60. Given the nature of the groove 64, the entry portion 62 preferably terminates at a

wall 68, such that when the female connector 80 is matingly engaged with the male connector 60 (i.e., pushed axially toward the male connector 60), the wall 68 defines a stop for the protrusion 82 of the female connector 60. When the protrusion 82 contacts the stop, axial movement of the female connector 60 is stopped and the protrusion 82 is appropriately aligned with the groove 64.

5 At this point, the female connector 80 (or the burner tube 40a, 40b) is twisted or rotated such that the protrusion 82 is received into the groove 64, as depicted in Figure 5. As an alternative or in combination with the wall 68, an additional stop can be formed by a second wall 70 which is adapted to contact a distal end 88 of the female connector 80 when the protrusion 82 is aligned with the groove 64.

10 Referring again to Figure 2, the P-tube 40a is shown in the assembly orientation wherein the female connector 80 is aligned for axial engagement with the male connector 60. That is, the protrusion 82 is circumferentially aligned with the entry portion 62. In the assembly orientation, the loop of the P-tube 40a is preferably vertically oriented, which facilitates insertion of the first portion 46 of the burner tube 40a into the opening 30 in the wall 28 of the lower member 22.

15 The orientation of the P-tube in the assembly orientation is dependent upon the relative location of the protrusion 82 to the burner tube orifices 44 and the relative location of the entry portion 82 to horizontal. As depicted, the entry portion 62 is horizontally aligned and is directed towards the back of the grill (referenced herein as the 270° position) whereas the protrusion 82 is offset from the burner tube orifices 44 by 180°. As such, when the burner tube 40a is in the assembly

20 orientation, the protrusion 82 is positioned at 270° (in alignment with the entry portion 62) while the orifices are pointed towards the 90° position (towards the front of the grill).

Turning now to Figure 1, the burner tube 40a, 40b is shown in the working orientation wherein the female connector 80 is locked into engagement with the male connector 62; i.e., the female connector 80 cannot be moved axially relative to the male connector 60. This positive connection between the connectors 60, 80 is enabled by engagement between the protrusion 82 and the groove 84, as is better shown in Figure 5. To reach this position, the burner tube 40a is first moved into mating engagement with the male connector 60 such that the protrusion 82 is aligned with the groove 64. Then, the burner tube 40a is rotated relative to the male connector 60 such that the protrusion 82 enters the groove 84. In the configuration depicted in the Figures, the burner tube is rotated 90° counterclockwise (i.e., when facing the leading edge 72 of the male connector 60). As such, in the working condition, the orifices 44 are preferably directed towards the 0° position and the protrusion 82 is preferably positioned at 180°. Note that the assembly and working positions of the protrusion 82 and the orifices 44 depend upon the chosen orientation of the entry portion 62 of the male connector 60 and the relative angle between the protrusion 82 and the orifices 44; i.e., the assembly and working positions of the protrusion 82 and the orifices 44 can infinitely vary. Consequently, the angles described herein are included for example purposes and are not intended to limit the breadth of the claims in any manner.

When the burner tube 40a is rotated into the working orientation, the orifices 44 are preferably upwardly directed for proper operation of the grill 10. Furthermore, the quick-connect fitting (i.e. the male and female connectors 60, 80) serve to secure the burner tube 40a to the grill 10 at the first portion 46 of the burner tube 40a. To more securely attach the burner tube 40a to the grill, the burner tube 40a is preferably provided with a bracket 50 for attaching to the

lower member 22, as shown in Figure 1. The bracket 50 can be attached directly or indirectly to the lower member 22 by any means known in the art. In the preferred embodiment, the lower member is provided with a mount 52 which is adapted to align with the bracket 50 when the burner tube 40a is rotated into the working orientation. The bracket 50 is preferably attached to
5 the mount 52 by bolting means.

Although the inventions described and claimed herein have been described in considerable detail with reference to certain preferred embodiments, one skilled in the art will appreciate that the inventions described and claimed herein can be practiced by other than the preferred embodiments, which have been presented for purposes of illustration and not of
10 limitation. Therefore, the spirit and scope of the appended claims should not be limited to the description of the preferred embodiments contained herein.

WE CLAIM:

1. A quick-connect fitting for connecting a burner tube to a fuel supply on a barbecue grill comprising:

a female connector and a male connector, wherein the female connector and the male connector are adapted to mate;

the female connector comprising a tubular body having an inwardly directed bridge formed therein, wherein the bridge defines a protrusion;

the male connector being generally cylindrical and having an entry portion and a groove;

the entry portion defining a pathway for receiving the protrusion; and,

the groove extending for at least a portion of a circumference of the male connector and being adapted to receive the protrusion after it is received by the entry portion and to lock the female connector to the male connector.

2. The quick-connect fitting of claim 1 wherein the bridge is chordal.

3. The quick-connect fitting of claim 1 wherein the male connector has a chamfered leading edge.

4. The quick-connect fitting of claim 1 wherein the male connector comprises a stop which is adapted to stop the female connector during axial engagement when the protrusion is aligned with the groove.

5. The quick-connect fitting of claim 1 wherein the male connector is aligned with an opening in the side of the grill.

6. The quick-connect fitting of claim 1 wherein the female connector is attached to the burner tube and the male connector is attached to a control valve of the grill.

7. The quick-connect fitting of claim 1 wherein the female connector is attached to a control valve of the grill and the male connector is attached to the burner tube.

8. A quick-connect fitting for connecting a burner tube to a fuel supply on a barbecue grill comprising:

a female connector and a male connector, wherein the female connector and the male connector are in mating engagement;

the male connector being generally cylindrical and having an entry portion and a groove; and,

the female connector comprising a tubular body having an inwardly directed protrusion which extends into the groove.

9. The quick-connect fitting of claim 8 wherein the male connector is attached to a valve of the grill, the female connector is attached to the burner tube, and a plurality of orifices on the burner tube are aligned in a working orientation.

10. The quick-connect fitting of claim 9 wherein the female connector is attached to a first portion of the burner tube, the male connector is disposed outside of a cooking chamber of the grill in alignment with an opening in the lower member of the cooking chamber, the first portion of the burner tube extends through the opening in the lower member, and a second portion of the burner tube is disposed inside of the cooking chamber.

11. The quick-connect fitting of claim 10 wherein the second portion of the burner tube comprises orifices which are upwardly directed.

12. The quick-connect fitting of claim 11 wherein the burner tube comprises a bracket which is aligned with a mount on the grill.

13. The quick-connect fitting of claim 12 wherein the inwardly directed protrusion is a chordal bridge.

14. The quick-connect fitting of claim 11 wherein the burner tube is P-shaped.

15. The quick-connect fitting of claim 9 wherein the plurality of orifices are upwardly directed.

16. The quick-connect fitting of claim 9 wherein the burner tube comprises a bracket which is aligned with a mount on the grill.

17. The quick-connect fitting of claim 9 wherein the male connector comprises a chamfered leading edge.

18. The quick-connect fitting of claim 9 wherein the male connector comprises a stop for aligning the protrusion with the groove.

19. A quick-connect fitting for connecting a burner tube to a fuel supply on a barbecue grill comprising:

a female connector and a male connector, wherein the female connector and the male connector are adapted to mate;

the female connector comprising a tubular body having an inwardly directed protrusion;

the male connector being generally cylindrical and having an entry portion and a groove;

the entry portion defining a substantially axial pathway being adapted to receive the protrusion;

the groove extending for at least a portion of a circumference of the male connector;

the groove being adapted to receive the protrusion after the protrusion is received by the entry portion; and,

the burner tube having an assembly orientation and a working orientation, wherein the protrusion and the entry portion are in alignment when the burner tube is in the assembly orientation and the protrusion is received by the groove when the burner tube is in the working orientation.

20. A quick-connect fitting for connecting a burner tube to a fuel supply on a barbecue grill comprising:

a female connector and a male connector, wherein the female connector and the male connector are adapted to mate;

the female connector having an inwardly directed protrusion and the male connector having an entry portion and a groove;

the entry portion defining a substantially axial pathway being adapted to receive the protrusion;

the groove extending for at least a portion of a circumference of the male

connector;

the groove being adapted to receive the protrusion after it is received by the entry portion; and,

the burner tube having an assembly orientation and a working orientation, wherein the burner tube is moved from the assembly orientation to the working orientation by rotational displacement, the protrusion and the entry portion are in alignment when the burner tube is in the assembly orientation, and the protrusion is received by the groove when the burner tube is in the working orientation.

21. A quick-connect fitting for connecting a burner tube to a fuel supply on a barbecue grill comprising:

a female connector and a male connector, wherein the female connector and the male connector are adapted to mate;

the male connector having an outwardly directed protrusion and the female connector having an entry portion and a groove;

the entry portion defining a substantially axial pathway being adapted to receive the protrusion;

the groove extending for at least a portion of a circumference of the female connector;

the groove being adapted to receive the protrusion after it is received by the entry portion; and,

the burner tube having an assembly orientation and a working orientation,

wherein the protrusion and the entry portion are in alignment when the burner tube is in the assembly orientation, and the protrusion is received by the groove when the burner tube is in the working orientation.

22. A quick-connect fitting for connecting a burner tube to a fuel supply on a barbecue grill comprising:

a female connector and a male connector, the female connector depending from the burner tube and the male connector depending from the fuel supply;

the female connector and the male connector defining a 90° locking interface, wherein the female connector and the male connector are adapted to be connected by a two step assembly;

in the first step, the male connector is received by the female connector in axial alignment, wherein the burner tube is in an assembly orientation; and,

in the second step, the male connector is rotated approximately 90°, wherein the burner tube is in a working orientation.

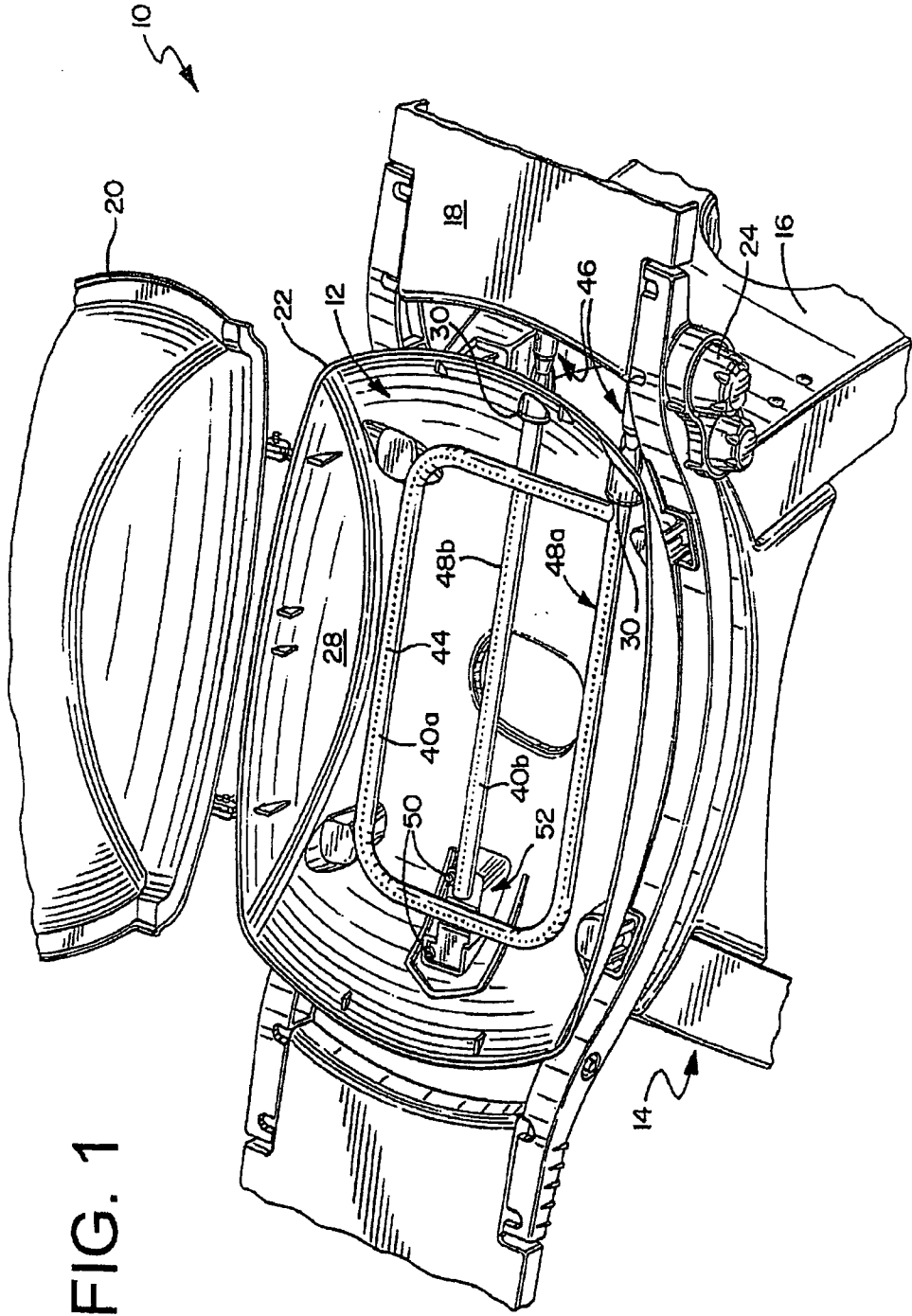

FIG. 1

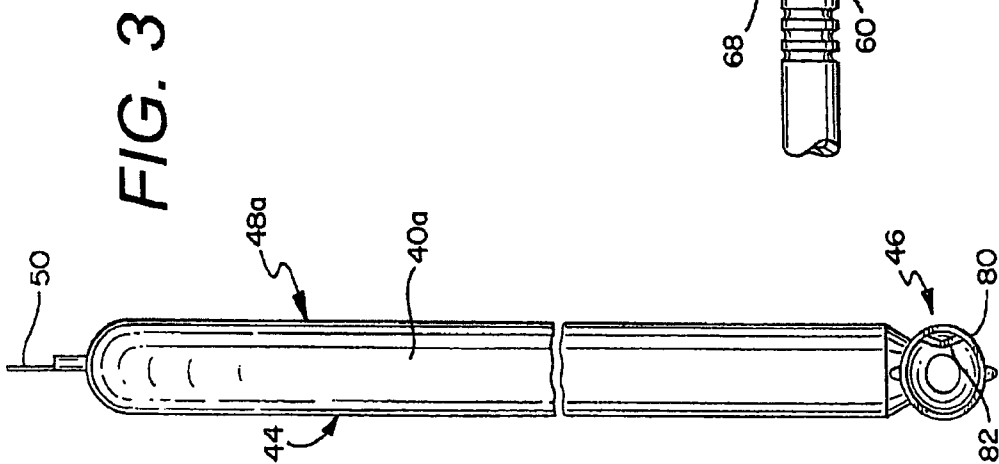

FIG. 3

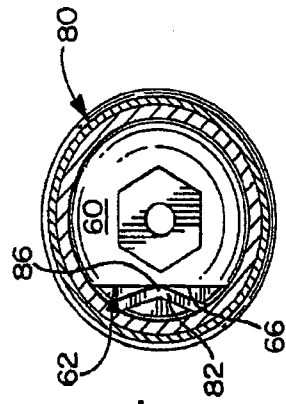

FIG. 4

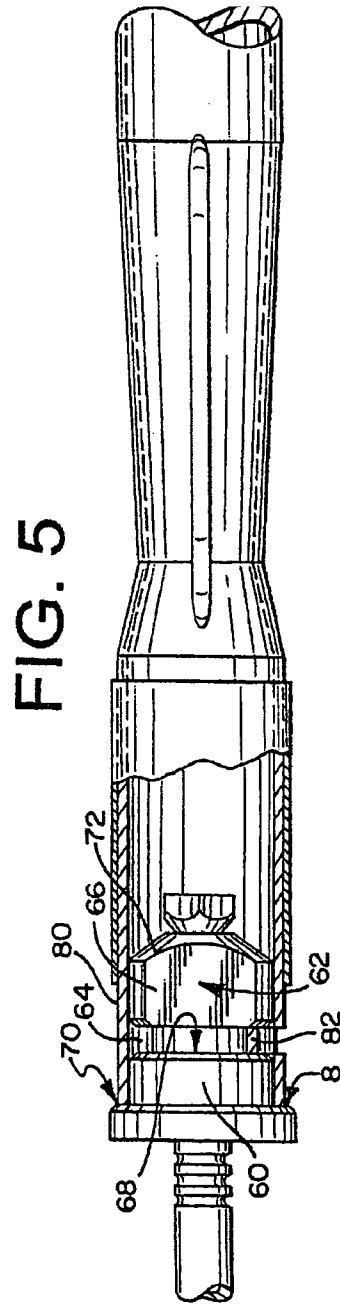

FIG. 5