

A. CASEY.
CASTING APPARATUS.
APPLICATION FILED OCT. 22, 1908.

940,302.

Patented Nov. 16, 1909.
2 SHEETS—SHEET 1.

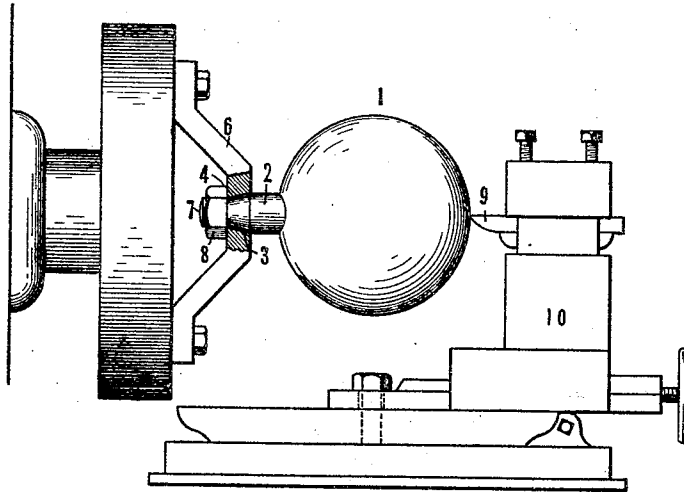
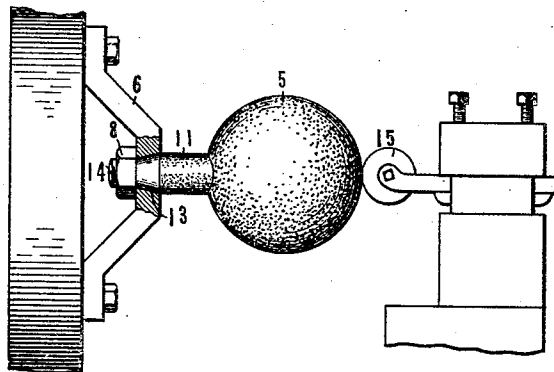

Fig. 1.

Fig. 2.



WITNESSES
Norman Perry
Paul Wolff

INVENTOR
Aubron Casey
BY
Wm. Casfield & Wm. ...
ATTORNEYS

A. CASEY,
 CASTING APPARATUS.
 APPLICATION FILED OCT. 22, 1908.

940,302.

Patented Nov. 16, 1909.
 2 SHEETS—SHEET 2.

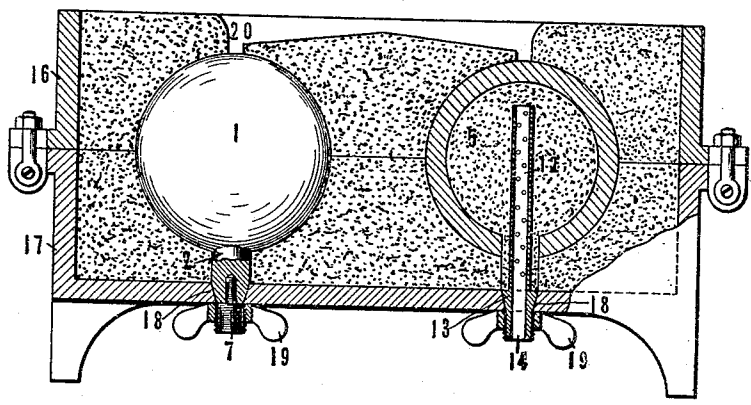

Fig. 3.

Fig. 4.

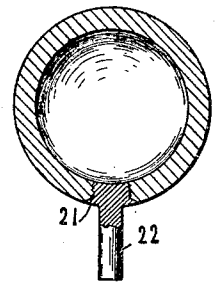
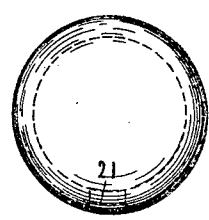

Fig. 5.



WITNESSES
Horatio Perry
Paul Aboeff

INVENTOR
Aubrey Casey
 BY
Duell, Waffley & Duell
 ATTORNEYS

UNITED STATES PATENT OFFICE.

AMBROSE CASEY, OF SENECA FALLS, NEW YORK, ASSIGNOR TO THE GOULDS MANUFACTURING COMPANY, OF SENECA FALLS, NEW YORK, A CORPORATION OF NEW YORK.

CASTING APPARATUS.

940,302.

Specification of Letters Patent.

Patented Nov. 16, 1909.

Application filed October 22, 1908. Serial No. 459,071.

To all whom it may concern:

Be it known that I, AMBROSE CASEY, a citizen of the United States, residing at Seneca Falls, in the county of Seneca and State of New York, have invented certain new and useful Improvements in Casting Apparatus, of which the following is a full, clear, and exact description, such as will enable others skilled in the art to which it appertains to make and use the same.

My invention relates to casting apparatus, and more particularly to a device of this character by means of which hollow articles may be formed.

One of the objects of my invention is to provide a device in which a hollow article may be formed which will have the same thickness throughout its area.

Another object of my invention is to provide a device of this character in which the pattern and the core may be easily and with certainty positioned within the molding flask in such a manner that the core will be centrally positioned within the mold formed by the pattern.

The invention accordingly consists in the features of construction, combinations of elements and arrangement of parts which will be exemplified in the construction hereinafter set forth, and the scope of the application of which will be indicated in the following claims.

In the accompanying drawing, wherein is shown one of various possible embodiments of this invention, Figure 1 is a side elevation of a portion of a lathe, illustrating the manner of constructing the pattern; Fig. 2 is a similar view illustrating the manner of constructing the core; Fig. 3 is a view of a flask showing two molds, one containing the pattern and the other containing the cast shell and the core, parts being shown in section for the sake of clearness; Fig. 4 is a sectional view of the hollow shell showing the method of filling the opening formed by the stem of the core; and Fig. 5 is an elevation of the finished article.

For the purpose of illustration, I have shown my device as adapted for the manufacture of hollow spherical metal shells.

Referring to the drawings, 1 indicates a pattern formed of wood or other suitable material and provided with a stem 2 having a tapering end portion 3 adapted to fit

closely within the tapering socket 4 formed in the face-plate 6 of the lathe. The stem is also provided with a threaded extension 7 adapted to be engaged by a nut 8 whereby the pattern is securely held in position. After the pattern has been secured, as described, it is turned or trued up to the desired dimensions and form by means of a suitable cutting tool 9 mounted upon a rotatable carriage 10 operated in the usual manner. I preferably so construct the pattern that it will have approximately the dimensions of the outer surface of the finished article in order that the casting may be finished or trued up to the exact size required, but, of course, if desired, I may make the pattern of the exact size of the finished article without in any way departing from the spirit of my invention. I next construct a destructible core 5 of sand or other suitable material, which is provided with a stem 11 and contains a centrally extending perforated tube 12 which projects through the stem and is provided with a tapering portion 13 corresponding in shape and size to the tapering portion 3 of the stem of the pattern. The core is also provided with a threaded extension 14 adapted to be engaged by the nut 8 whereby it may be held in position upon the face-plate of the lathe. The core is then turned or trued up to the exact form and dimensions of the interior of the hollow article required, said truing up being preferably accomplished by means of a grinding or abrading wheel 15 which may be substituted for the cutting tool 9 shown in Fig. 1. In carrying out this operation care must be taken that the grinding wheel is so located with respect to the core that when the core is finished the center of the spherical portion thereof will be exactly the same distance from its tapered end as the center of the pattern is distant from its tapered end.

Referring to Fig. 3 there is shown a molding flask or box consisting of upper and lower sections 16 and 17 which may be detachably secured together in any suitable manner. This box has formed in its lower portion one or more tapering sockets 18 corresponding in size and form with the tapering socket 4 in the face-plate of the lathe. When the sections of the flask have been separated the pattern is placed therein with its

tapering portion exactly coinciding with the tapering socket in the flask and it is retained in position by means of a thumb screw 19 or other suitable device which is adapted to engage with the threaded extension 7. After the pattern is so positioned, the sections of the flask are reassembled and sand is tamped or packed around the pattern in the usual manner and a gate-way or passage 20 is provided to receive the molten metal, as is usual in the art. The sections of the box are then separated and the pattern removed after which the core is inserted with its tapering portion fitting the tapering socket in which the pattern was previously held and the core is secured in position by means of the thumb screw engaging its threaded extension.

When the core is positioned, as described, the flask is reassembled and molten metal is poured through the gateway or passage until the intervening space is completely filled. As the center of the core is exactly the same distance from its tapering end portion as the center of the pattern is distant from its tapering end portion, it follows that the center of the core will be coincident with the center of the mold formed by said pattern, thus providing an intervening space of uniform thickness between said core and said mold. After the casting has become cooled the flask is again taken apart and the casting having the core therein is removed, after which the core is broken up in any suitable way and removed through the opening previously occupied by its stem. The opening in the casting may then be filled up by means of a suitable plug 21 which may be secured therein in any suitable manner, preferably by threading the shell and plug, as shown in Fig. 4. A stem 22 is preferably provided upon the plug by means of which the article may be supported in a lathe when it is desired to true up the same, after which the stem is cut off and the outer surface of the plug is smoothed to exactly correspond with the outer surface of the finished article, as shown in Fig. 5. It will thus be seen that I have provided a device in which the core may be easily and with certainty so arranged within the mold that there will be an intervening space of uniform thickness between it and the mold.

As many changes could be made in the above construction and many apparently widely different embodiments of this invention could be made without departing from the scope thereof, it is intended that all matter contained in the above description or shown in the accompanying drawing shall be interpreted as illustrative and not in a limiting sense. It is also to be understood that the language used in the following claims is intended to cover all of the generic and specific features of the invention herein

described, and all statements of the scope of the invention which, as a matter of language, might be said to fall therebetween.

Having described my invention, what I claim as new and desire to secure by Letters Patent is:—

1. An apparatus of the nature disclosed for casting spherical shells comprising in combination, a mold box comprising two sections separable in a divisional line coincidental with a diameter of the spherical shell to be cast, one of said sections having a wall substantially in parallelism with said divisional line and provided with a socket, a spherical pattern having a stem adapted to directly interfit in said socket and of such length that a diameter of said spherical pattern will coincide with the divisional line of said section, and a spherical core of less diameter than said pattern and having a stem adapted to directly interfit in said socket and of such length as to position said core concentrically within the space formed by said pattern.

2. An apparatus of the nature disclosed for casting spherical shells comprising in combination, a mold box comprising two sections separable in a divisional line coincidental with a diameter of the spherical shell to be cast, one of said sections having a wall substantially in parallelism with said divisional line and provided with a socket, a spherical pattern having a stem provided with a tapered end adapted to directly interfit in said socket and of such length that a diameter of said spherical pattern will coincide with the divisional line of said section, and a spherical core of less diameter than said pattern and having a stem provided with a tapered end adapted to directly interfit in said socket and of such length as to position said core concentrically within the space formed by said pattern.

3. In a device of the class described, in combination, a sectional mold box provided with a tapering socket, a pattern and a core each of which is provided with a stem having a tapering portion adapted to directly fit within said socket.

4. In a device of the class described, in combination, a sectional mold box provided with a tapering socket, a pattern and a core each of which is provided with a stem having a tapering portion adapted to directly fit within said socket, the stem of said core being longer than the stem of said pattern.

5. In a device of the class described, in combination, a sectional mold box provided with a tapering socket, a pattern and a core each having a tapering stem adapted to directly engage said socket, and means removably engaging said stems whereby the pattern and core may be held in position within said box.

6. In a device of the class described, in

combination a sectional mold box provided with a tapering socket, a pattern and a core each having a tapering stem adapted to engage said socket, each of said stems being provided with a threaded extension, and a thumb screw having a threaded opening adapted to engage said threaded extension.

7. In a device of the class described, in combination, a sectional mold box provided with a tapering socket, a pattern and a core each of which is provided with a stem having a tapering portion adapted to fit within said socket, the tapering portion of the stem of said pattern being of the same size and shape as the tapering portion of the stem of said core.

8. In a device of the class described, in combination, a mold box comprising a plurality of sections one of which is provided with a socket, a one-piece pattern having a stem adapted to engage said socket and a core having a stem adapted to directly engage said socket, the stem of said core being longer than the stem of said pattern.

9. In a device of the class described, in combination, a mold-box comprising a plurality of sections one of which is provided with a plurality of sockets, a one-piece pattern having a stem adapted to engage either of said sockets, and a core having a stem longer than the stem on said pattern to directly engage either of said sockets after the pattern has been removed whereby a plurality of hollow, spherical bodies may be cast simultaneously.

10. In a device of the class described, in combination, a mold-box comprising a plurality of sections one of which is provided with a tapered socket, a pattern having a stem adapted to engage said socket, and a core having a stem longer than the stem of said pattern adapted to directly engage said socket after the pattern is removed whereby a hollow spherical body may be cast having a wall of uniform thickness throughout.

11. An apparatus of the nature disclosed, for casting spherical shells comprising in combination, a mold-box composed of a plurality of sections, one of said sections having a tapering socket arranged to flare toward the interior of said mold-box, a pattern having the shape of a complete

sphere and provided with a protruding short stem integrally terminating in a taper adapted to exactly interfit with said socket and detachable therefrom whereby said spherical pattern may be precisely positioned relative to said section, and a core of friable material having the shape of a complete sphere of less diameter than said pattern-sphere and provided with a protruding stem integrally terminating in a taper exactly counterpart to the taper of said pattern-stem, said protruding core-stem exceeding the pattern-stem in length a distance equal to one-half the difference between the diameters of the pattern and the core respectively.

12. An apparatus of the nature disclosed, for casting spherical shells comprising in combination, a mold-box composed of a plurality of sections, one of said sections comprising side walls having a bottom wall positively secured thereto, said bottom wall having a tapering socket, a one-piece pattern having the shape of a complete sphere and provided with a protruding short-stem integrally terminating in a taper adapted to exactly interfit with said socket and detachable therefrom, whereby said spherical pattern may be precisely positioned relatively to said bottom wall and at a distance therefrom, and a core having the shape of a complete sphere of less diameter than said spherical pattern and provided with a protruding stem integrally terminating in a taper exactly interfitting with said taper socket, the length of said protruding core-stem exceeding the pattern stem a distance equal to one-half the difference of the diameters of the pattern and core respectively, and the portion of said core-stem intervening between the bottom wall of said mold-section and the part of the spherical pattern nearest said bottom being the counterpart in cross-section of the corresponding portion of the pattern stem.

In testimony whereof I affix my signature, in the presence of two witnesses.

AMBROSE CASEY.

Witnesses:

WM. D. PAUENY,
C. J. COONS.