

May 6, 1958

J. H. PHILLIPS
EXPANSION SHELL HOLDER

2,833,519

Filed July 8, 1953

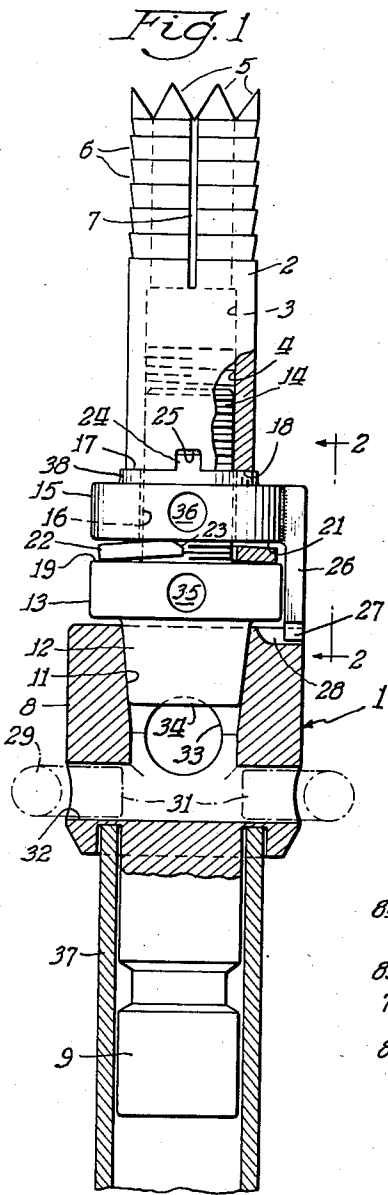

Fig. 2

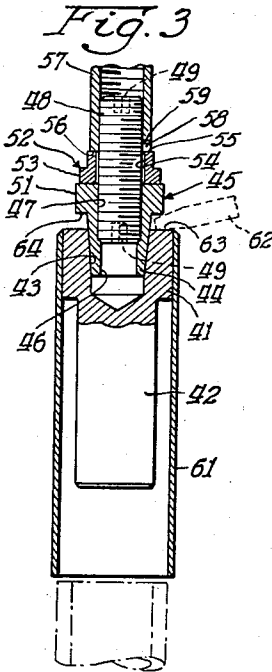
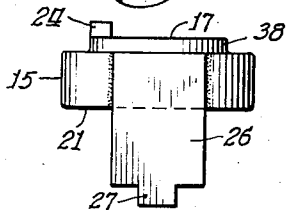

Fig. 5

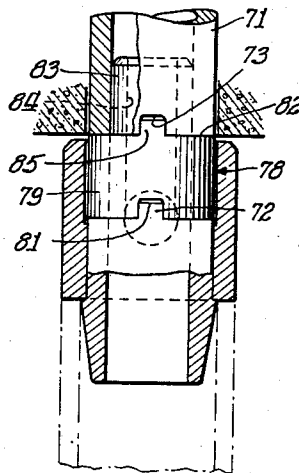

Fig. 6

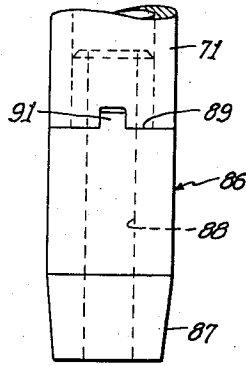
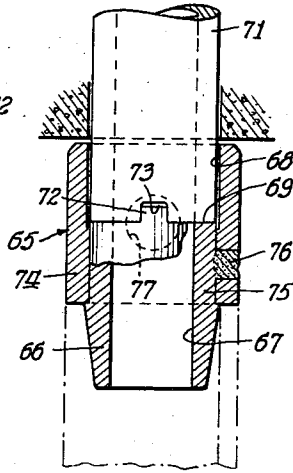

Fig. 4



Inventor:
John H. Phillips
By: *Shee & Shee*

Attys.

1

2

2,833,519

EXPANSION SHELL HOLDER

John H. Phillips, Chicago, Ill., assignor to Phillips Drill Company, a corporation of Illinois

Application July 8, 1953, Serial No. 366,834

5 Claims. (Cl. 255—72)

The invention relates to tool holders, and more particularly to holders adapted for holding self-drilling expansion shells and similar devices.

The present invention is of particular use in connection with the installation of expansion shells and the like, wherein the shell is adapted to be mounted flush with the surface of the object to which it is applied and may embody some of the features illustrated in my co-pending application, Serial No. 366,833, filed July 8, 1953, now Patent No. 2,794,622, issued June 4, 1957 which discloses the use of a resilient structure in connection with the mounting of the shell on the holder.

The present invention has among its objects the production of a holder structure particularly suitable for use with flush type self-drilling expansion shells and the like, wherein the shell may be non-rotatably locked with respect to the holder structure and to a shell and holder having cooperable means thereon for effecting such results.

Another object of the invention is the production of such a holder construction which is especially adapted for use with flush type, self-drilling expansion shells and the like where the latter are to be mounted, and thus the holes to be drilled, in an overhead surface, as for example, a ceiling or the like, the construction providing means for the passage of chips and shavings through the holder structure, thus eliminating the necessity of periodically withdrawing the shell from the object during the drilling operation.

A further object of the invention is the production of a novel holder structure having the above advantages which is so designed that shells of different sizes may be accommodated thereby, including novel means for interchanging the adapter elements employed with different sized shells, as well as novel means by which the holder may be manually rotated in use.

Another object of the invention is the production of a novel holder structure having a threaded stem adapted to receive the threaded portion of an expansion shell or the like, the holder being so designed that such threaded stem may be readily removed from the holder structure and replaced when desired.

Many other objects and advantages of the construction herein shown and described will be obvious to those skilled in the art from the disclosure herein given.

To this end my invention consists in the novel construction, arrangement and combination of parts herein shown and described, and more particularly pointed out in the claims.

In the drawings, wherein like reference characters indicate like or corresponding parts:

Fig. 1 is a side elevational view of a holder having an expansion shell mounted thereon, portions of the holder being shown in section to disclose the details thereof;

Fig. 2 is a side elevation view of the locking member employed in the holder illustrated in Fig. 1, taken approximately on the line 2—2 of Fig. 1;

Fig. 3 is a sectional view of a holder structure and portion of a shell illustrating novel means for manually rotating the holder structure;

Fig. 4 is an axial sectional view of an adapter structure for use with holder structures such as illustrated in Figs. 1 and 3, and designed for use in mounting shells or the like in overhead objects;

Fig. 5 is a view similar to Fig. 4 illustrating the use of an insert in conjunction with the structure illustrated in Fig. 4; and

Fig. 6 is a side elevational view of an adapter embodying the features of the insert and adapter illustrated in Fig. 5.

The present invention contemplates the use of a holder having means adapted to receive and support an expansion shell or other similar tool or device, the holder and the expansion shell being provided with cooperable means for preventing relative rotation between the shell and the holder structure. In the embodiment of the invention illustrated, the holder is provided with a lug or projection adapted to be positioned in a cooperable notch in the shell, thereby effecting a mechanical interlock therebetween which assures rotation of the shell with the holder structure during drilling operations, which for most efficient results requires the rotation of the drill member relative to the material being drilled during the cutting operation. In one form of the invention, the holder is provided with a threaded stem adapted to enter the threaded bore of an expansion shell or the like, and in another form of the invention, the holder structure is of hollow construction adapted to provide a socket or the like in which the shell is supported, such hollow construction permitting passage and discharge of chips and shavings from the shell during drilling operations in overhead surfaces.

The construction illustrated in Figs. 1 and 2 presents the application of the present invention to a holder structure which includes features disclosed and covered in my co-pending application, Serial No. 366,833. Mounted on the holder structure indicated generally by the numeral 1, is a self-drilling expansion shell 2 having a hollow bore 3 therethrough which is threaded adjacent one end as indicated at 4 and provided with cutting teeth 5 at its opposite free end. The shell 2 may also be provided with a plurality of annular-shaped grooves 6 and longitudinally extending fracture grooves 7 which are commonly employed in shells of this type.

The holder 1 in the embodiment of the invention illustrated in Fig. 1 comprises a generally cylindrically shaped body member 8, having an axially extending shank 9 at one end thereof for engagement with a suitable power tool, the opposite end of the body member having a tapered bore 11. Seated in the bore 11 is a complementally shaped tapered shank 12 of an adapter member 13, the latter having an outwardly directed axially extending threaded stem 14 of a size to operatively engage the threaded portion 4 of the shell with which it is to be employed. Encircling the stem 14 is a collar 15 having a bore 16 therein of a size to permit free axial movement of the collar 15 along the stem 14, the collar 15 having an end face 17 adapted to engage the adjacent end face 18 of the shell 2. Interposed between the face 19 of the adapter member 13 and the adjacent face 21 of the collar 15 is a resilient expansion member 22, the latter being generally similar in shape to a split type of lock washer but having its free ends, only one of which is illustrated in Fig. 1, rounded or otherwise suitably shaped as indicated at 23 to eliminate the typical locking action associated with common lock washers.

Extending axially outwardly from the face 17 of the collar 15 is a generally rectangular-shaped lug or projection 24 cooperable with a generally similarly shaped

3

notch 25 in the end face 18 of the shell 2, whereby rotation of the shell relative to the collar 15 is restricted. Means is also provided for restricting rotation of the collar 15 relative to the body member 8, which means, in the embodiment of the invention illustrated, comprises a projection or arm 26 extending generally parallel to the axis of the device toward the body 8, with the free end of the projection 26 terminating in a tongue 27 adapted to be positioned in a suitably sized notch 28 in the end face of the body member 8. Thus relative rotation of the shell with respect to the collar 15 is restricted by the projection 24, on the collar 15, and notch 25 in the shell, while rotation of the collar relative to the body member is restricted by engagement of the tongue 27, carried by the collar 15, with the notch 28 in the body member, whereby the shell 2 and body member 1 are operatively locked together.

Suitable means may be provided for effecting rotation of the holder 1 relative to the power tool with which it is to be employed, as for example, a bale 29 indicated in dotted lines, which may be of generally U-shaped construction having opposed, aligned end portions 31 positioned in a transversely extending bore 32 in the body member, this construction being very similar to that previously employed in connection with the other types of rotatable holder devices. The body member 8 may also be provided with a transversely extending bore or hole 33 adapted to intersect the inner end 34 of the adapter 13 and providing means for the insertion of a suitable pry-bar or the like which may be engaged with the inner end 34 of the adapter 13 and axially directed force exerted thereon to disengage the adapter from the body member.

In use, the shell 2 may be manually rotated on the stem 14, engaging the projection 24 on the collar 15 with the notch 25 of the shell as the latter advances on the stem 14 and when the shell 2 and collar 15 have reached the end of hand rotation, the collar and adapter may be engaged with respective tools inserted in radially directed bores 35 and 36 in the adapter and collar. If desired, the adapter and collar may be provided with suitably shaped portions for engagement with suitable wrenches in place of the bores 35 and 36. Thus the shell may be advanced on the stem 14 by rotating the collar 15 relative to the adapter 13, this action being continued until the respective elements have partially compressed the resilient member 22. Upon completion of the assembly of the shell on the adapter 13, the latter may be engaged with the body member 8, with the tongue 27 positioned in the notch 28 of the body member. The shank 9 of the holder may then be inserted in the chuck 37 of the power tool with which it is to be used and the teeth 5 of the shell engaged with the surface to be drilled.

As the drilling operation continues, the body member 8 and with it the collar 15 and shell 2 may be rotated by means of the bale or handle 29. Where a power hammer is being used, the bale 29 provides means for manually rotating member 8 simultaneously. Where a rotary power tool is employed, the bale 29 may be removed. Upon completion of the hole, the shell 2 is withdrawn therefrom, and the chips and shavings knocked out of the bore 3. A tapered plug or wedge is then placed in the toothed end of the shell, following which the plug and shell are again driven into the drilled hole until the end of the shell is flush with the mounting surface, this action resulting in driving of the plug or wedge into the shell which will fracture along the grooves 7, permitting the segments to expand and rigidly lock the shell in the hole. The collar 15 may be provided with a boss 38 adjacent the end face 17 thereof which boss may be approximately the same or slightly larger in diameter than that of the shell with which it is to be used, similar to the construction shown and described in my co-pending application heretofore referred to. It will be noted that the collar 15 provides

4

means by which the shell 2 may be positively rotated relative to the stem 14. As the shell is necessarily hardened to withstand the cutting operations, it will be very difficult to forcibly rotate the shell relative to the stem 14 by means of a wrench or tool applied directly to the shell. However, by means of the present construction such rotation may be readily accomplished. The resilient member 22 prevents a wedging or jamming action between the collar 15 and adapter 13 which would tend to make disengagement of the shell difficult, as well as providing a cushioning action between the shell and the adapter 13 and body member 8.

After the hole has been drilled and the shell mounted therein, the holder structure may be disconnected from the shell by disconnecting the adapter 13 from the body member 8 in the manner heretofore described, and then rotating the adapter 13 relative to the shell 2 and collar 15 in a direction to withdraw the stem 14 from the shell.

The construction illustrated in Fig. 3 discloses a holder structure which is of particular advantage in connection with the utilization of relatively small sized shells and includes novel means for manually rotating the holder structure. In this construction the body member 41 is provided with a shank 42 of a size to operatively engage the tool with which it is to be employed and is provided at its opposite end with a tapered bore 43 of a size to receive the tapered shank 44 of the adapter member 45. The latter is provided with an axially extending bore 46 therethrough which is provided with internal threads as indicated at 47 adjacent the free or outer end of the adapter, such threads, however, terminating intermediate the ends of the adapter. Engaged with the threaded portion 47 of the adapter is an externally threaded stem 48, the latter having a tool-engaging recess 49 in either or both ends, providing means for operatively engaging a suitable wrench or tool with the stem 48, as for example, the recesses 49 may be of square, hexagonal or other cross section, adapted to receive a complementally shaped tool. The peripheral portions 51 of the adapter 45 are preferably formed in the shape of a hex or other suitable shape which will provide means for engagement with a suitable wrench so that the stem 48 may be readily inserted in the bore 46 and rotated until the inner end of the stem engages or wedges with the unthreaded portion of the bore, thus firmly locking the two elements together, encircling the stem 48 is a collar 52 having its peripheral portions 53 suitably formed for engagement with a wrench or other tool, the collar 52 having a bore 54 of a size to permit free axial movement of the collar relative to the stem 48.

Extending outwardly from the end face 55 of the collar 52, which is adapted to engage the adjacent end face 56 of the shell 57, is a suitable projection 58 adapted to enter the notch 59 in the shell 57, the notch 59 corresponding to the notch 25 of the shell 2. In this construction, the collar 56 is illustrated as engaging the adapter member 51 and functions primarily to provide means for effecting positive rotation of the shell 57 relative to the stem 48 and adapter member 45. However, if desired, a suitable resilient element similar to the element 22 illustrated in Fig. 1 could be inserted between the adapter member 45 and the collar 52. Extending from the body member 41 in concentric relation with respect to the shank 42 thereof is a tubular handle or gripping element 61 which is adapted to encircle the chuck of the usual power tool with which the device is to be employed, a portion of such chuck being indicated in broken lines in Fig. 3. Thus in use the shell may be rotated through the body member 41 by manually grasping the tubular member 61 and thereby rotating the holder structure. In this embodiment of the invention, the adapter 52 may be removed from the body member 41 by inserting a pry-bar 62 indicated in dotted lines between the end faces 63 of the body member 41 and the annular shoulder 64 of the adapter.

The constructions illustrated in Figs. 4, 5, and 6 are directed to adapters particularly designed for supporting flush type shells during drilling and expanding operations in overhead objects or surfaces such as ceilings and the like. Referring to Fig. 4, the adapter indicated generally by numeral 65 is provided with a tapered shank 66 adapted to engage a suitable body member of a holder structure such as the body member 8 of Fig. 1 or body member 41 of Fig. 3, and is provided with an axially extending bore 67 which is counterbored, as indicated at 68, adjacent the end thereof opposite the shank portion 66, thus forming an annular shoulder 69 on which the inner end of a shell 71 is adapted to seat. Extending outwardly from the shoulder 69 is a generally rectangularly-shaped projection 72 corresponding to the projection 24 of the projection 58 which is adapted to enter the notch 73 in the adjacent end of the shell 71. The adapter 65 may be fabricated in any suitable manner, as for example, as two separate elements consisting of a shank 66 and a sleeve 74 which is adapted to encircle the upper portion 75 of the shank, with the shoulder 69 formed by the top edge of the shank. The sleeve 74 may be rigidly secured to the shank by any suitable means, as for example, by drilling a hole in the side wall of the sleeve 74 and welding the two elements together thereat as indicated generally by the numeral 76. To facilitate engagement of the notch 73 in the shell with the projection 72, the sleeve 74, prior to its securement with the shank, may be provided with an opening 77 in the side wall thereof adjacent the projection 72, and notch 73.

The adapter 65 may be engaged with the shell and utilized in the drilling operation until the adapter approaches the surface of the object being drilled, following which an insert member is assembled therewith to permit drilling until the shell end is flush with the mounting surface.

Such an insert member 78 is illustrated in Fig. 5, and comprises a cylindrical body member 79 of approximately the same diameter as the shell 71, thus permitting its insertion in the adapter 65. The inner end of the body member 79 is provided with a notch 81 therein of a size to receive the projection 72, thereby locking the insert to the adapter. Extending axially outward from the opposite end face 82 of the insert 78, is an unthreaded stem 83 of a diameter to enter the threaded portion of the shell and support the latter thereon, the body 79 and stem 83 having an axial bore 84 therethrough. Also extending outwardly from the end face 82 is a projector or lug 85 corresponding to the lug 72 and adapted to engage the notch 73 of the shell in the same manner as the lug 72.

In use, the adapter 65 is initially utilized with the shell as illustrated in Fig. 4, and following drilling to the extent permitted by the adapter during which operation chips and cuttings may pass through the shell and adapter, the shell is removed therefrom, the insert 78 added, and the shell replaced on the insert as illustrated in Fig. 5. The drilling may then be completed, any additional cuttings or chips resulting therefrom accumulating in the shell or passing through the bore 85 and thus rendering removal of the shell unnecessary during the final drilling operation. After the hole is completed, the shell is removed, any chips discharged therefrom, the shell reinserted in the hole with the usual expansion plug or wedge, and expanded by means of the adapter insert assembly.

Figure 6 illustrates an adapter for performing the functions of the structure illustrated in Fig. 5, the adapter 86 having a tapered shank portion 87 corresponding to the shank 66 and an axially extending unthreaded stem 90 at the opposite end corresponding to the stem 83. The adapter 86 is also provided with an axial bore 88 therethrough and the end face 89 of the adapter is also provided with a projection 91 corresponding to the pro-

jection 85 of the insert. Thus the adapter 86 comprises in an integral structure the functional features of the adapter and insert assembly or combination, and functions in the same manner. When using this structure, following initial drilling with the construction illustrated in Fig. 4, the adapter 65 is removed from the holder and the adapter 86 substituted therefor.

It will be noted that in all of the constructions illustrated, means is provided for restricting rotation of the shell relative to the holder structure whereby the shell may be rotated during the drilling operation and that novel cooperable means is provided on both the shell and the holder for accomplishing these results.

Likewise I have provided a novel holder structure for use on ceiling and other overhead applications. The holders illustrated are simple in construction, inexpensive to manufacture and very efficient for the purposes intended. Likewise by providing removable adapters, a single holder may be utilized for a number of different sized shells, eliminating the necessity of procuring a number of relatively costly holder structures, each of which may accommodate only a single size of shell.

Having thus described my invention, it is obvious that various immaterial modifications may be made in the same without departing from the spirit of my invention; hence, I do not wish to be understood as limiting myself to the exact form, construction, arrangement and combination of parts herein shown and described or uses mentioned.

What I claim as new and desire to secure by Letters Patent is:

1. In a holder for drill members and the like, having a threaded mounting bore, the combination of a body member having a threaded stem extending from a face therein of a size to engage the threaded bore of such a drill member, a collar having a passageway therein through which said stem extends, the diameter of the passageway being greater than the diameter of the stem, said collar having integral reduced dimension projection means thereon engageable with such a drill member to prevent relative rotation therebetween, a spring compression member interposed between said collar and said face of the body member having said stem freely passed therethrough, said collar being freely rotatable on said stem relative to the body member to enable the drill member to be drawn down on the stem with the compression ring compressed between the collar and body member.

2. In a holder for drill members and the like, having a threaded mounting bore, the combination of a body member having a threaded stem extending from a face therein of a size to engage the threaded bore of such a drill member, a collar having a bore therein of a size to permit the free axial passage of said stem therethrough, said collar having integral projecting lug means engageable with such a drill member to restrict relative rotation therebetween, and resilient ring means interposed between said collar and said face of the body member arranged to be compressed when the stem is threadedly engaged entirely in said drill member bore.

3. In a holder for drill members and the like, having a threaded mounting bore, the combination of a generally cylindrical body member, an adapter member, the latter and said body member having cooperable means integral therewith for connecting the same in axially aligned relation, said adapter member having a threaded stem extend from a face thereof of a size to engage the threaded bore of a drill member, a collar having a bore therein through which said stem extends, said collar having rigid projection means thereon engageable with such a drill member to restrict relative rotation therebetween, a spring compression member interposed between said collar and said face of the adapter member, said collar and drill member being rotatable together relative said adapter for rotating such a drill member to draw the latter down on said stem and to compress said compression member.

4. In a holder for drill members and the like, having

a threaded mounting bore, the combination of a generally cylindrical body member, an adapter member, the latter and said body member having cooperable means for connecting the same in axially aligned relation, said adapter member having a threaded stem extending from a face thereof of a size to engage the threaded bore of a drill member, a collar having a bore therein through which said stem extends, said collar and drill member having a tongue and slot connection one with the other to restrict relative rotation therebetween, said collar providing means for rotating such a drill member to draw the latter down on said stem, and cooperable interlocking means on said collar and said body member for restricting relative rotation therebetween.

5. In a holder for drill members and the like, having a threaded mounting bore, the combination of a generally cylindrical body member, an adapter member, the latter and said body member having cooperable means for connecting the same in axially aligned relation, said adapter member having a threaded stem extending from a face thereof of a size to engage the threaded bore of a drill member, a collar having a bore therein through which said stem extends, said collar and drill member

having a tongue and slot connection one with the other to restrict relative rotation therebetween, said collar providing means for rotating such a drill member to draw the latter down on said stem, and a longitudinally extending projection rigidly carried by said collar, said projection extending toward said body member, the latter having a recess therein in which said projection may be positioned when the adapter member is operatively engaged with said holder, said notch and projection being operative to prevent relative rotation between said collar and the holder.

References Cited in the file of this patent

UNITED STATES PATENTS

161,082	Wiser	Mar. 23, 1875
448,165	Robison	Mar. 10, 1891
1,392,702	Phillips	Oct. 4, 1921
1,408,947	Johnson	Mar. 7, 1922
1,996,121	Phillips	Apr. 2, 1935
2,365,835	Paget	Dec. 26, 1944
2,419,901	Lake	Apr. 29, 1947
2,572,307	Brown et al.	Oct. 23, 1951