

(19) World Intellectual Property Organization
International Bureau



(43) International Publication Date
28 March 2002 (28.03.2002)

PCT

(10) International Publication Number
WO 02/25630 A2

- (51) International Patent Classification⁷: **G10K**
- (21) International Application Number: PCT/US01/29487
- (22) International Filing Date:
20 September 2001 (20.09.2001)
- (25) Filing Language: English
- (26) Publication Language: English
- (30) Priority Data:
60/233,961 20 September 2000 (20.09.2000) US
09/845,521 26 April 2001 (26.04.2001) US
- (71) Applicant (for all designated States except US): **MOLECULAR REFLECTIONS** [US/US]; Suite 102, 6310 Nancy Ridge Drive, San Diego, CA 92121 (US).
- (72) Inventors; and
- (75) Inventors/Applicants (for US only): **NERENBERG, Michael, I.** [US/US]; 8178 Gilman Court, La Jolla, CA 92037 (US). **LIU, Kelvin, J.** [US/US]; 5275 Toscana Way, #117, San Diego, CA 92122 (US).
- (74) Agents: **WILSON, Barry, S.** et al.; Foley & Lardner, P.O. Box 80278, San Diego, CA 92138-0278 (US).
- (81) Designated States (national): AE, AG, AL, AM, AT, AU, AZ, BA, BB, BG, BR, BY, BZ, CA, CH, CN, CO, CR, CU, CZ, DE, DK, DM, DZ, EE, ES, FI, GB, GD, GE, GH, GM, HR, HU, ID, IL, IN, IS, JP, KE, KG, KP, KR, KZ, LC, LK, LR, LS, LT, LU, LV, MA, MD, MG, MK, MN, MW, MX, MZ, NO, NZ, PL, PT, RO, RU, SD, SE, SG, SI, SK, SL, TJ, TM, TR, TT, TZ, UA, UG, US, UZ, VN, YU, ZA, ZW.
- (84) Designated States (regional): ARIPO patent (GH, GM, KE, LS, MW, MZ, SD, SL, SZ, TZ, UG, ZW), Eurasian patent (AM, AZ, BY, KG, KZ, MD, RU, TJ, TM), European patent (AT, BE, CH, CY, DE, DK, ES, FI, FR, GB, GR, IE, IT, LU, MC, NL, PT, SE, TR), OAPI patent (BF, BJ, CF, CG, CI, CM, GA, GN, GQ, GW, ML, MR, NE, SN, TD, TG).
- Published:**
— without international search report and to be republished upon receipt of that report
- For two-letter codes and other abbreviations, refer to the "Guidance Notes on Codes and Abbreviations" appearing at the beginning of each regular issue of the PCT Gazette.

(54) Title: MICROFABRICATED ULTRASOUND ARRAY FOR USE AS RESONANT SENSORS

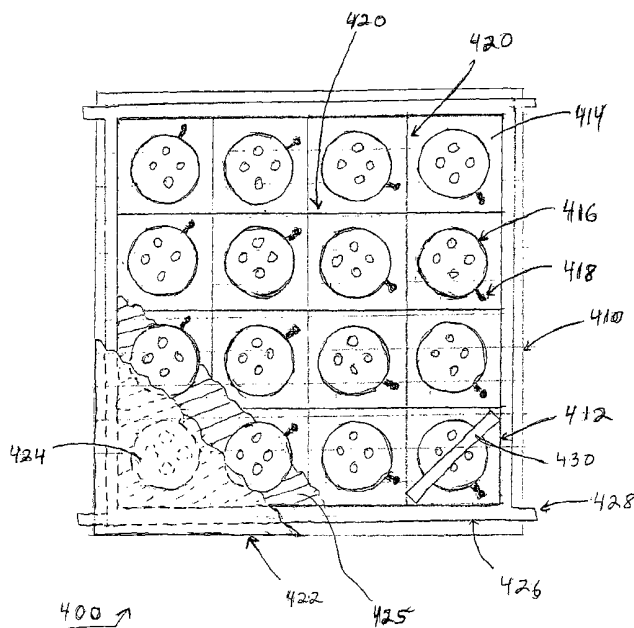

(57) Abstract: Apparatus and methods are provided for microfabricated sensors for use as resonant sensors. In one embodiment, an array of sensors is formed by having an electrically common membrane, an insulative spacer and a base including a driving element. Optionally, electrostatic drive forces cause the membrane to resonate, and a binding event is detected. Detection may be capacitive, piezoelectrical, piezoresistive or optical. Optional vents permit equilibration to atmosphere. Detection circuitry including phase lock loop circuitry or tunable oscillator circuitry may be utilized. High throughput screening, such as for drug discovery can be achieved.



WO 02/25630 A2

Microfabricated Ultrasound Array For Use As Resonant Sensors

FIELD OF THE INVENTION

The present invention relates to sensors for monitoring a change in force as
5 applied to a surface membrane or a change in the surface properties of the sensor
membrane. More particularly, the invention relates to a microfabricated mechanical
resonant sensor that individually or in an array may be used for the characterization of
molecular binding interactions.

RELATED APPLICATION INFORMATION

10 This application is related to U.S. Provisional Application Serial No.
60/233,961, entitled "Methods and Apparatus for Synthesis and Detection of Biological
Molecules", filed on September 20, 2000, and a continuation of U.S. Application Serial
No. 09/845,521, entitled "Microfabricated Ultrasound Array For Use As Resonant
Sensors", filed April 26, 2001, both of which are incorporated by reference herein
15 including any figures and drawings.

BACKGROUND

This invention relates to the fabrication and use of acoustic resonant micro-
sensors individually or in combination as an array in screening assays to determine the
presence or amount of an analyte. The sensors of the invention are useful in detecting
20 analytes in both aqueous and gas environments.

The following description is provided to assist the understanding of the reader.
None of the information provided or references cited is admitted to be prior art to the
present invention.

Technological advances in combinatorial chemistry, genomics, and proteomics
25 have fostered an increased need for rapid high throughput (HTP) screening methods
able to monitor and/or detect the reaction between one or more target species and
binding partners or potential binding partners of such targets. Various systems have
been, and are being, explored to detect analytes. Systems such as affinity chemical
sensing, arrayed sensors, and acoustic sensors are being investigated for their respective
30 usefulness in detecting analytes in clinical and non-clinical settings.

Affinity Chemical Sensing

Affinity chemical sensing systems attempt to detect interactions between a target analyte and an appropriate binding partner. Such systems generally rely on the production or use of a detectable signal. Affinity chemical sensing systems employ
5 binding partners which can be discrete molecular species to which the target analyte specifically binds, or a phase, such as an organic polymer, into which the target partitions. Covalently attached labels such as, fluorescent, electrochemical, radioactive, or mass based-probes are typically employed in such systems. Methods for
10 determining the presence analytes by using systems that detect the inherent optical, electrochemical, or physical properties of a target species or changes in the properties of the layer containing the binding partner to which a target species binds, have been employed to detect and/or monitor un-labeled analytes.

Charych, *et al.*, US Patent 6,022,748, filed August 29, 1997, describe an example of a sensor employing an optically active sensor coating that changes color
15 upon binding of the target. Further example of affinity sensing methods are described by W. Lukosz, "Principles and sensitivities of integrated optical and surface plasmon sensors for direct affinity sensing and immunosensing", *Biosensors & Bioelectronics* 6, 1991, pp. 215-225. Utilization of surface plasmon resonance in sensing applications is also described by Hanning in US patent 5,641,640, filed December 29, 1994. A
20 Chemically Selective Field Effect Transistor (CHEMFET) that determines target binding by monitoring a signal change on the sensor surface in response to target binding to the said surface, is described by Shimada in US Patent 4,218,298, filed November 3, 1978. Ribi *et al.*, in US Patents 5,427,915 and 5,491,097, filed August 9, 1993 and February 28, 1994 respectively, describe affinity-based microfabricated
25 sensors in which a measurable change in conductivity of a bio-electric sensor layer is used to determine binding of a target species.

Arrayed Sensors

Arrayed sensors have multiple individually addressable sites on the device surface which are modified to contain binding partners for a target molecule to be
30 detected. An example of such a detection system can be found in US Patent 6,197,503, filed November 26, 1997 by in Vo-Dinh *et al.* The patent describes a device employing multiple optical sensing elements and microelectronics on a single

integrated chip combined with one or more nucleic acid-based bioreceptors designed to detect optically labeled, sequence specific genetic constituents in complex samples.

Other examples of arrayed sensors include: Pinkel *et al.*, US Patent 6,146,593 filed July 24, 1997, describe a method for fabricating biosensors using functionalized optical fibers to create a high density array of uniquely addressable biological binding partners; Fodor *et al.*, US Patent 6,124,102 filed April 21, 1998 describe an optical sensor array having a planar surface derivatized with ligands of an optically active target species immobilized at known locations such that each location comprises a “pixel” of an optical read out device. These and similar devices can be successful for arrayed detection and therefore useful for parallel screening of multiple interactions where the analyte is either labeled or inherently optically, electrically, or specifically chemically active.

Acoustic Sensors

Another field of technology having combine arrayed sensors is that of sensors based on bulk or microfabricated resonant devices. Such sensors have been demonstrated in systems used to determine 3-dimensional acceleration, speed, and position, as transducers for monitoring environmental conditions such as pressure, fluid flow, temperature, and as gravimetrically sensitive elements in chemical affinity sensors.

Acoustic sensors for chemical sensing have been demonstrated in low-density arrays in for example Ballato US Patent 4,596,697 filed September 4, 1984 which describes surface acoustic wave (SAW) devices. Arrays of cantilever sensors for gas phase sensing of multiple analytes are described by Lang et al (Lang, H.P.; Baller, M.K.; Berger, R.; Gerber, Ch.; Gimzewski, J.K.; Battiston, F.M.; Fornano, P.; Ramseyer, J.P.; Meyer, E.; Guntherodt, H.J.; IBM Research Report, RZ 3068 (#93114), 10/19/98), and Britton et al (Britton, C.L.; Jones, R.L.; Oden, P.I.; Hu, Z.; Warmack, R.J.; Smith, S.F.; Bryan, W.L.; Rochelle, J.M.; Ultramicroscopy, 82, 2000, p. 17-21).

SUMMARY OF THE INVENTION

The invention described herein relates to microfabricated resonant sensors that can be used individually or as an interconnected yet electrically isolated grouping in microarrays. The invention relates to an electromechanical sensor for monitoring a

change in surface properties of a sensor membrane. The change in surface properties results from a binding event that changes the physical characteristics of the membrane surface, such as surface mass, viscous coupling, membrane stiffness, and the like. The sensors of the invention can also be used to determine a change in force on the surface of a sensor membrane, such as results from a binding event or application of pressure. A sensor can be part of an array of sensors which can be fabricated to high density. The sensors of the invention have many applications including, for example, to determine the presence or amount of an analyte in a sample from a clinical, research or natural environment. In this case, a binding partner of the analyte can be immobilized to the resonant sensor membrane surface and the binding of analyte to the binding partner on the membrane can be identified through a shift in the resonant characteristics of the sensor membrane.

The term "sensor" as used herein relates to an apparatus or device that can respond to an external stimulus such as, a change in mass on a surface, pressure, force, or a particular motion, where the apparatus can transmit a resulting signal to be measured and/or detected.

The term "binding event" refers to an interaction or association between a minimum of two molecular structures, such as an analyte and a binding partner. The interaction may occur when the two molecular structures are in direct or indirect physical contact. Examples of binding events of interest in the present context include, but are not limited to, ligand/receptor, antigen/antibody, enzyme/substrate, DNA/DNA, DNA/RNA, RNA/RNA, nucleic acid mismatches, complementary nucleic acids, nucleic acid/proteins, and the like.

As used herein "microfabricated" refers to the procedures and/or methods, such as bulk and surface micromachining, used to etch, deposit, pattern, dope, form and/or fabricate structures using substrates such as silicon and the like. Microfabrication procedures are known in the art and have been used to prepare microsystems such as computer processor chips, acoustic sensors, micro-circuits and other devices requiring micron and nanomolecular scale portions used in fields such as microengineering.

In one aspect, the present invention provides a micromechanical sensor for detecting a change in force at a membrane surface or a change in the surface properties of the sensor membrane. The apparatus or sensor of the invention comprises a substrate and one or more layers formed on or in the substrate. The substrate and/or

layers form a cavity comprising one or more side walls and a membrane that covers the top of the cavity. The cavity side walls can be flat, angled, sloped or curved. In preferred embodiments, the membrane provides a substantial barrier to liquid entry through the top of the cavity. The cavity also comprises at least two electrodes, which
5 include an upper electrode and a lower electrode. The upper electrode can be the membrane itself or the upper electrode can be fabricated on, within or below the membrane. The lower electrode is below the membrane. The composition and dimension of the membrane are chosen so that it can vibrate or resonate in response to changes in electrical signal from the lower and/or upper electrode. Preferably, the
10 membrane is responsive to a change in resonant frequency and/or a harmonically varied electrical current. More preferably, the membrane is harmonically responsive to a change in force on the membrane surface or surface properties of the membrane, for example a binding event near and/or on the membrane surface. Preferably the diameter or width of a sensor of the invention is between at least 5 and up to 200 microns. More
15 preferably the diameter or width of a sensor is between 10 to 100 microns.

“Liquid free” as used herein refers to the micromachined or naturally occurring cavity of the sensor being substantially free of any fluid or fluid-like material, for example water or gelatinous materials.

The term "analyte" or "target" refers to any molecule being detected by the
20 sensor. The analyte (or target) is detected by immobilizing one or more binding partners (or “probes”) or presumed binding partners specific for the analyte or target to a sensor membrane. Thus, when it is desired to use the sensor to determine if a gas or solution contains an analyte, the surface of the sensor membrane that is to contact the gas or solution is immobilized with a binding partner for that analyte. Analyte and its
25 binding partner represent a binding pair of molecules, which interact with each other through any of a variety of molecular forces including, for example, ionic, covalent, hydrophobic, van der waals, and hydrogen bonding, so that the pair have the property of binding specifically to each other. Specific binding means that the binding pair exhibit binding with each other under conditions where they do not bind to another
30 molecule. Examples of types of specific binding pairs are antigen-antibody, biotin-avidin, hormone-receptor, receptor-ligand, enzyme-substrate, IgG-protein A, and the like.

Preferred binding partners and/or analytes of the present invention include, but are not limited to, antibodies, antigens, nucleic acids (e.g. natural or synthetic DNA, RNA, gDNA, cDNA, mRNA, tRNA, etc.), lectins, sugars, oligosaccharides, glycoproteins, receptors, growth factors, cytokines, small molecules such as drug candidates (from, for example, a random peptide library, a natural products library, a legacy library, a combinatorial library, an oligosaccharide library and a phage display library), metabolites, drugs of abuse and their metabolic by-products, enzyme substrates, enzyme inhibitors, enzyme co-factors such as vitamins, lipids, steroids, metals, oxygen and other gases found in physiologic fluids, cells, cellular constituents, cell membranes and associated structures, cell adhesion molecules, natural products found in plant and animal sources, tumor markers (i.e., molecules associated with tumors), other partially or completely synthetic products, and the like.

Analytes or binding partners may be naturally occurring or synthetically prepared. A "natural analyte" is an analyte which occurs in nature and specifically binds to a particular site(s) on a particular binding partner such as a protein. Examples by way of illustration and not limitation include a receptor and a ligand specific for the receptor (e.g., an agonist or antagonist), an enzyme and an inhibitor, substrate or cofactor; and an antibody and an antigen.

The terms "isolated," "purified," or "biologically pure" mean an object species is the predominant species present (i.e., on a molar basis it is more abundant than any other individual species in the composition), and preferably a substantially purified fraction in a composition wherein the object species comprises at least about 50 percent (on a molar basis) of all macromolecular species present. Generally, a substantially pure composition will comprise more than about 80 to 90 percent of all macromolecular species present in the composition. Most preferably, the object species is purified to essential homogeneity (contaminant species cannot be detected in the composition by conventional detection methods) wherein the composition consists essentially of a single macromolecular species.

The term "nucleic acid" refers to a deoxyribonucleotide or ribonucleotide polymer in either single- or double-stranded form, and also encompasses known analogs of natural nucleotides that can function in a similar manner as naturally occurring nucleotides.

"Polypeptide", "peptide," "protein" and "protein target" are used interchangeably to refer to a polymer of amino acid residues. The terms apply to amino acid polymers in which one or more amino acid residue is an artificial chemical analogue of a corresponding naturally occurring amino acid, as well as to naturally occurring amino acid polymers. An analyte and/or its binding partner can be a protein. The protein or protein target to which ligands are being screened in drug discovery methods is essentially any type capable of binding some type of ligand including, by way of example and not limitation, for example, enzymes, receptors, antibodies and fragments thereof, hormones, and nucleic acid binding proteins. A protein or peptide may include a particular site, this site is the site at which a ligand and the protein or peptide form a binding complex. For an enzyme, the particular site can be the active site or an allosteric site; in the instance of a receptor, the particular site is the site at which a natural ligand binds.

The term "antibody" refers to a protein consisting of one or more polypeptides substantially encoded by immunoglobulin genes or fragments of immunoglobulin genes. The recognized immunoglobulin genes include the kappa, lambda, alpha, gamma, delta, epsilon and mu constant region genes, as well as myriad immunoglobulin variable region genes. Light chains are classified as either kappa or lambda. Heavy chains are classified as gamma, mu, alpha, delta, or epsilon, which in turn define the immunoglobulin classes, IgG, IgM, IgA, IgD and IgE, respectively.

A typical immunoglobulin (antibody) structural unit is known to comprise a tetramer. Each tetramer is composed of two identical pairs of polypeptide chains, each pair having one "light" (about 25 kD) and one "heavy" chain (about 50-70 kD). The N-terminus of each chain defines a variable region of about 100 to 110 or more amino acids primarily responsible for antigen recognition. The terms variable light chain (VL) and variable heavy chain (VH) refer to these light and heavy chains respectively. An antibody can be specific for a particular antigen. The antibody or its antigen can be either an analyte or a binding partner.

Antibodies exist as intact immunoglobulins or as a number of well-characterized fragments produced by digestion with various peptidases. Thus, for example, pepsin digests an antibody below the disulfide linkages in the hinge region to produce $F(ab)_2$, a dimer of Fab which itself is a light chain joined to VH-CH1 by a disulfide bond. The $F(ab)_2$ may be reduced under mild conditions to break the

disulfide linkage in the hinge region thereby converting the (Fab')₂ dimer into an Fab' monomer. The Fab' monomer is essentially an Fab with part of the hinge region (see, Fundamental Immunology, W. E. Paul, ed., Raven Press, N.Y. (1993), for a more detailed description of other antibody fragments). While various antibody fragments are defined in terms of the digestion of an intact antibody, one of skill will appreciate that such Fab' fragments may be synthesized *de novo* either chemically or by utilizing recombinant DNA methodology. Thus, the term antibody, as used herein also includes antibody fragments either produced by the modification of whole antibodies or synthesized *de novo* using recombinant DNA methodologies. Preferred antibodies include single chain antibodies, more preferably single chain Fv (scFv) antibodies in which a variable heavy and a variable light chain are joined together (directly or through a peptide linker) to form a continuous polypeptide.

A single chain Fv ("scFv") polypeptide is a covalently linked VH::VL heterodimer which may be expressed from a nucleic acid including VH- and VL- encoding sequences either joined directly or joined by a peptide-encoding linker. Huston, et al. (1988) Proc. Nat. Acad. Sci. USA, 85:5879-5883. A number of structures for converting the naturally aggregated--but chemically separated light and heavy polypeptide chains from an antibody V region into an scFv molecule which will fold into a three dimensional structure substantially similar to the structure of an antigen-binding site. See, e.g. U.S. Pat. Nos. 5,091,513 and 5,132,405 and 4,956,778.

An "antigen-binding site" or "binding portion" refers to the part of an immunoglobulin molecule that participates in antigen binding. The antigen binding site is formed by amino acid residues of the N-terminal variable ("V") regions of the heavy ("H") and light ("L") chains. Three highly divergent stretches within the V regions of the heavy and light chains are referred to as "hypervariable regions" which are interposed between more conserved flanking stretches known as "framework regions" or "FRs". Thus, the term "FR" refers to amino acid sequences that are naturally found between and adjacent to hypervariable regions in immunoglobulins. In an antibody molecule, the three hypervariable regions of a light chain and the three hypervariable regions of a heavy chain are disposed relative to each other in three dimensional space to form an antigen binding "surface". This surface mediates recognition and binding of the target antigen. The three hypervariable regions of each of the heavy and light chains are referred to as "complimentarily determining regions" or "CDRs" and are

characterized, for example by Kabat et al. Sequences of proteins of immunological interest, 4th ed. U.S. Dept. Health and Human Services, Public Health Services, Bethesda, Md. (1987). An epitope is that portion of an antigen that interacts with an antibody.

5 "Sample" refers to essentially any source from which an analyte can be obtained. A sample may be acquired from essentially any organism, including animals and plants, as well as cell cultures, recombinant cells, cell components and can also be acquired from environmental sources. Samples can be from a biological tissue, fluid or specimen and may be obtained from a diseased or healthy organism. Samples may
10 include, but are not limited to, sputum, amniotic fluid, blood, blood cells (e.g., white cells), urine, semen, peritoneal fluid, pleural fluid, tissue or fine needle biopsy samples, and tissue homogenates. Samples may also include sections of tissues such as frozen sections taken for histological purposes. Typically, samples are taken from a human. However, samples can be obtained from other mammals also, including by way of
15 example and not limitation, dogs, cats, sheep, cattle, and pigs. The sample may be pretreated as necessary by dilution in an appropriate buffer solution or concentrated, if desired. Any of a number of standard aqueous buffer solutions, employing one of a variety of buffers, such as phosphate, Tris, or the like, preferably at physiological pH can be used. A sample also may be artificially prepared such as a control sample that
20 contains a known amount of an analyte.

By "environmental sources" it is meant potentially any place in the natural and/or man-made environment from which a sample can be taken. Environmental sources include: water sources such as oceans, lakes, ponds, rivers and streams; earthen sources such as soil, sand, interior or exterior dust; gas sources such as air, such as
25 polluted and/or non-polluted air from our general surroundings or from industrial plants or automotive exhaust and the like.

Biological samples can be derived from patients using well known techniques such as venipuncture, lumbar puncture, fluid sample such as saliva or urine, or tissue biopsy and the like. Biological samples also include exhaled air samples as taken with
30 a breathalyzer or from a cough or sneeze. A biological sample may be obtained from a cell or blood bank where tissue and/or blood are stored, or from an in vitro source, such as a culture of cells. Techniques for establishing a culture of cells for use as a source for biological materials are well known to those of skill in the art. Freshney, Culture of

Animal Cells, a Manual of Basic Technique, Third Edition, Wiley-Liss, N.Y. (1994) provides a general introduction to cell culture.

As used herein the term “membrane response” relates to the vibration or resonance of the membrane layer that is extended over, or placed on, and roughly covers, in a sealed liquid impermeable, manner a cavity of the invention sensor. Upon the introduction of a current or formation of an electrostatic potential, the membrane of the invention can move, vibrate or oscillate in a manner that can be measured, for example, acoustically, electronically by electromechanical transduction such as by electrostatics/capacitance, piezoresistance or piezoelectricity, or optically by interferometry, such as laser-Doppler vibrometry. The extent of vibration or oscillation of the membrane depends, for example, on the physical properties of the membrane and its relation to another electrode in the cavity or the effect of mass or force on the membrane surface.

The term “substrate” is used herein to refer to the starting material from which the sensor of the invention is fabricated. The substrate can comprise single crystal silicon, glass, gallium arsenide, silicon insulator, silicon-on-sapphire, and indium phosphate, and the like. Also, combinations of these materials can be used. Preferably, the substrate has a high electrical resistance, such as a P or N-type silicon wafer rated up to $15,000\Omega \cdot \text{cm}$. In a particular embodiment, the substrate comprises a silicon wafer, double side polished, P or N-type substrate having a resistance between 5 and $15,000\Omega \cdot \text{cm}$. More preferably, the substrate is a double side polished, silicon wafer, P or N-type having a resistance of roughly $10,000\Omega \cdot \text{cm}$. The substrate of the sensor can comprise one or more dopants, for example boron and/or phosphorus, to be patterned as one or more electrodes, and any vents, passages or holes within the cavity can extend through the substrate.

Sensor layers that are added to the substrate during sensor fabrication can comprise single crystal silicon, polysilicon, silicon nitride, silicon dioxide, phosphosilicate glass, borophosphosilicate glass, aluminum nitride, zinc oxide, polyvinylidene fluoride, lead zirconate, metal, and the like. Combinations of these materials also can be used. The layers can have different electrical properties from the substrate. For example, some layers of a sensor can be used to aid in electrically isolating one region, the upper region for example, of a sensor from a lower region, or

in another example, can provide electrical isolation of the membrane and the electrode(s). Layers also may be used to form electrodes and/or electrode leads. For example, a sensor layer having a cavity, can have a via, or a channel etched in the most planar surface, the XY horizontal surface of the substrate, connecting an electrode to a side wall, or the base of the cavity. This channel can be lined with a passivating layer and filled with a doped polysilicon, or a metal, such as titanium, metal alloy, titanium, gold, platinum, tungsten, aluminum, and the like, and then an additional layer having a different resistance can be placed on top of the now filled channel. In forming such layers, and in preparing electrodes and leads of the present invention it would be recognized that the area of the sensor that carries an electrical charge from an electrical power source should be electrically isolated from other regions of the sensor in order to avoid a failure of conductivity, or a short, of the electrodes and leads.

In another embodiment, the sensor layers and electrodes can be arranged by taking a substrate and applying a passivating layer, for example oxide or nitride, to provide an insulating layer between the substrate and any electrodes. Electrodes can be formed by depositing and patterning metal on the surface of the passivating layer. Another layer, a patterned spacer layer can be added with an area of the spacer layer being defined as the sensor cavity. The cavity of the sensor can be formed by etching away the defined area in the spacer layer and preferably the cavity is formed above the electrode. A membrane layer is then placed over and sealed on top of the cavity.

As used herein, "electrically isolate," "electrical isolation," and like terms when used in reference to electrodes, leads, arrays and sensors of the invention, refer to arranging sensors and components of sensors in a manner that insulates the array, sensor, electrode or lead that transports or carries a current of electricity from surrounding layers, sensors, electrodes or leads. For example an array having more than one sensor in close proximity to other sensors that are electrically isolated can have essentially all of a current applied to at least one sensor in the array. Electrical isolation of sensor elements in an array can be accomplished by forming a p/n-junction between the conducting paths and the substrate. A p-n junction can be formed by doping the two halves of a single piece of a semiconductor, or two opposing layers, so that they become, respectively, p-type and n-type material, by doing this an interface is formed between the two halves creating a p-n junction. Such p-n junctions have the property that it does not allow current will flow and the junction is said to be backward

biased. In another embodiment, the sensor, array, lead or electrode can be insulated by ensuring that materials used to surround the component are incapable of conducting an electrical current. Electrical isolation could also be obtained by physically separating sensors in an array, by arranging the sensors in a manner in which they do not
5 substantially contact another sensor yet are present on the same array.

The membrane of the sensor can be polygonal or elliptical. In a preferred embodiment, is rectangular or square having sides of 5 to 100 microns in length. More preferably, the membrane is circular having a radius of 2 and up to 100 microns, 2 to 30 or 2.5 to 50 microns in length. The membrane of the invention covers a prepared,
10 micromachined, microfabricated or naturally occurring cavity in the substrate and can cover the cavity in a manner that prevents a liquid from entering the cavity. Preferably the membrane is up to .5 microns thick. More preferably the membrane is at least .05 and up to .5 microns thick.

The membrane or membrane layer of the sensor can be fabricated from an
15 electrically conductive material, such as doped single crystal silicon, doped polysilicon, metal or any composite thereof, and can serve as a connection to ground. In alternative embodiments, the membrane can be fabricated out of non-conductive materials such as silicon nitride, silicon dioxide, phosphosilicate glass, borophosphosilicate glass. In this case, the membrane is not an electrode but can have an electrode fabricated within, on,
20 above or below the surface. As discussed herein, the membrane covers roughly the entire opening of the cavity in a substantially sealed manner. The membrane of the sensor can also serve to conduct an electrical signal. In another embodiment the membrane layer can be fabricated to contain one or more secondary structures that can conduct a current of electricity such as piezoelectric or piezoresistive materials. In
25 selecting a material to serve as a membrane for the invention sensor, certain mechanical characteristics such as Young's Modulus, which refers to the stiffness of the membrane, the density, the intrinsic stress, and internal damping are considered. In a preferred embodiment of the present invention the membrane is prepared or fabricated in a manner that allows the membrane to vibrate and/or resonate. The membrane can also
30 be fabricated to either serve as an electrode for conducting electricity, or as a connection to ground. The membrane can serve as part of a capacitive or electrostatic pair. Within this embodiment, the membrane and the other electrode of the pair are

separated by the space of the cavity and/or materials within the cavity, and act as a capacitor like structure.

In another embodiment the present invention provides a sensor comprising a cavity that is preferably 0.1 to 2 microns deep and sealed with an addressable,
5 conductive membrane. In a preferred embodiment the membrane is preferably 0.1 to 0.5 microns in thickness. The sensor membrane resonate or vibrate and can be used as a chemical affinity sensor. For example, the topmost surface of the membrane can be derivatized to comprise at least one member of a binding pair. In following, upon
10 exposure to a solution or gas phase that contains a second member of the binding pair, binding occurs between the two molecules and an increase in mass relative to the mass of the single membrane bound member occurs on the membrane. This change in mass at the surface of the membrane can alter the resonant characteristics of the membrane and/or the fundamental frequency of vibration or the phase of a vibration relative to a driving signal of the membrane can be said to change and/or shift.

By the term "addressable" when describing the electrical potential of the sensor, membrane, electrode or an array, is meant that the described layer, sensor, substrate and/or membrane can accept an electron, have an electric potential or voltage
15 assignment. The electric potential can be the assignment of having a ground voltage, such as for example the membrane can be held at ground voltage when a sensor operates using an AC, alternating current, power source, or the assignment can be a
20 lower or higher electric potential within the membrane in reference to an opposing electrode if using a DC, direct current, electrode power source. The term "addressable" when used to describe a sensor when placed in an array, combines the concept of assigning an electric potential or voltage and relates to each sensor being capable of
25 being given a specific locator and/or identifier, allowing a particular sensor in an array to be separately identifiable from surrounding sensors when used in methods such as high through put screening.

As discussed above, the present invention sensor comprises a cavity that is covered by a membrane as described herein. Preferably, the cavity comprises one or
30 more walls that are .1 to 2 microns in height. More preferably, the cavity walls are .3 to 1 micron in height, creating a cavity or a well that is roughly .3 to 1 micron deep. It is the distance between the upper electrode and lower electrode that determines the height of the cavity. Thus, the distance from the lower to upper electrode is roughly .3 to 1.

In a preferred embodiment, the cavity is completely covered in a sealed, liquid free manner by the membrane. In another embodiment, the membrane that completely covers the cavity comprises one or more holes on its surface.

5 Within an aspect of the present invention, it is the cavity that serves as the dielectric space between the electrode in the bottom of the cavity and the upper electrode. It would be understood by one of ordinary skill in the art that combination of the lower and upper electrode comprise a capacitor system where the cavity is, as stated, the dielectric space through which an electrostatic field can be formed.

10 In another embodiment, the cavity of the sensor has passages, or vents, which are holes in the substrate that connect the exterior of the sensor to the cavity. In a preferred embodiment, the cavity can be vented, having holes, tunnels or pores which allow the cavity to be vented to the external atmosphere of the sensor. Vents in the cavity of the sensor function to eliminate and/or relieve the effects of barometric pressure variation and pressurization in the cavity during operation of the device. The
15 passages or vents can be in the base, the sidewalls of the cavity, or in the membrane which covers the cavity. Thus, in a particular aspect, the sensor of the invention has a sealed cavity being covered by a membrane having vents. The cavity can be partially filled, or filled with a dielectric or multiple dielectric materials or gases, such as tantalum, polypropylene film, polymer-aluminum, polyester, metalized polyester,
20 plastic foam sheet, transformer oils such as paraffin, gasses such as argon, oxygen, chlorine, and any mixture of the like. Preferably, the cavity comprises at least one passage or vent which passes in the Z or perpendicular dimension, through the substrate and to the exterior and/or ambient surroundings of the sensor. The vents and/or passages can extend in a horizontal or planar manner from the cavity through the walls
25 of the cavity well or in another embodiment the vents and/or passages can extend through the floor of the cavity leading in a perpendicular manner to the exterior of the sensor.

 The sensor of the present invention can comprise at least two electrodes as mentioned above. Electrodes in the sensor cavity are preferably planar. The electrodes
30 of the sensor can be created by etching vias or channels into the substrate, providing a passivating insulating layer and implanting or sputtering a metal, for example titanium, gold, platinum, tungsten, a metal alloy and/or other like metals. It is also an aspect of the invention to dope the substrate with an impurity which depending on the type of

substrate chosen, p-type or n-type, can indicate either a substance such as boron, P-type, or phosphorus, N-type, to act as leads and/or electrodes. In another embodiment, the electrodes of the sensor can be formed of one or more metal or diffused dopant electrode layers in the bottom of the cavity.

5 Leads are used to connect electrodes to a power source or ground. The leads can be prepared by fabricating holes or tunnels through the substrate cavity which lead away from the cavity in a perpendicular manner. Such perpendicular leads can be prepared to extend through the substrate to the exterior of the sensor in order to be connected to an electrical current source, or the leads can extend from the substrate
10 cavity floor and be configured to exit the sensor at an angle, through one or more sides of the sensor itself.

 In another embodiment, the electrodes can be part of, or reside on or within the membrane of the sensor. One of ordinary skill in the art would recognize that preparation of electrodes on, within or under the membrane should not interfere with
15 either the acoustics of the cavity, nor should they interfere with the resonance, oscillation or vibrations of the membrane itself. It is within this aspect of the invention that one or more electrodes are prepared on, within or under the membrane to serve as actuating electrodes and/or sensing electrodes, and it is also within aspects of the invention to have electrodes on, within or under the membrane and have additional
20 electrodes as described above.

 Resonation or vibration of the membrane can be initiated electrostatically through use of electrodes in the sensor base, the membrane, the cavity wall, the cavity floor and/or membrane where the electrodes are connected in a manner that allows the initiation or creation of an electric current and/or potential. Resonation or vibration of
25 the membrane of the sensor can be monitored using electrodes that can be located in and around the sensor as described and illustrated herein, and which can be part of a monitor apparatus, or monitoring can occur, for example, either acoustically, electronically by electromechanical transduction such as by electrostatics/capacitance, piezoresistance or piezoelectricity, or optically by interferometry, such as laser-Doppler
30 vibrometry..

 In another aspect of the present invention, the above described sensor(s) can be arranged in an array from as few as a handful of sensor sites to as many as 500,000 individual sensors per cm^2 . High density arrays can comprises between 256 to 150,000

individual sensors/ cm,² and more preferably between 5,000 to 100,000 sensors/cm.² Each sensor in the array can be fabricated to generally function similarly. However, in some embodiments, individual sensor sites may have different types of sensors, which differ in their mode of operation. It is preferred that individual sensors sites are
5 arranged in the array in a manner that allows for electrical isolation of each sensor. In some embodiments, the individual sensor sites can be individually addressed. In other embodiments, multiple sensor sites may be linked so that they can be actuated and detected simultaneously.

In another embodiment, the present invention provides high density arrays
10 having multiple sensors where individual sensors of the array have a cavity differing in width, depth and shape. The individual sensors of an array can also comprise membranes of different width and composition. For example, one or more sensors of an array can comprise membranes with or without holes on their surfaces. In a preferred embodiment, the individual sensors of high density arrays comprise the same
15 cavity shape and depth and further comprise membranes and substrates of the same width and composition. More preferably, the individual sensors of an array are essentially identical in shape and composition, and are individually addressable. Within this aspect of the invention a high density array can also comprise sensors that are grouped together to detect the same analyte.

20 Arrays of the present invention can be used in multi-plexed assays which can be considered assays where more than one analyte is detected in a sample. For example an array can be prepared with multiple sensors each having different binding partners. A sample believed to contain any of the multiple analytes of interest can be placed in contact with the sensor array and various individual sensors can be monitored, based on
25 the membrane response, to determine which analytes are present in the sample. It would be understood by those of skill in the art that more than one sensor site in the array can be used as a control or reference sensor to determine reference values for the assay, such as the baseline response for the membranes. It would also be recognized by those skilled in the art that due to the size of the arrays, multiple arrays with probes for
30 multiple targets can be used simultaneously.

In another aspect of the present invention, a micromechanical sensor for the detection of a change in mass at a membrane surface of the sensor is provided. Preferably the change in mass is directly related to a binding event on or near the

surface of the membrane. As discussed above, the binding event can be between biological or chemical molecules and can be obtained from a variety of samples. Within this aspect of the invention, various assays that rely on the binding of one molecule to another can be utilized. Fields such as immunology, pharmacology, 5 biology, medicine, chemistry, molecular biology and other like fields of science have long utilized assays involving molecular and chemical binding events. Such assays including ELISA, DNA hybridization, immunoassay, competitive binding assays, sensitivity assays, affinity and rate binding assays and the like, rely on detection of optically or chemically detectable marker such as fluorescent marker which is bound to 10 the analyte of a binding pair. The present sensor or sensor arrays can perform these same assays and use the same marker labeled reagents, but in this case, the labeled reagents are detected through their increased mass, which is detected due to sensor related detectable changes in membrane resonance or vibration. Thus, while the invention described herein has been discussed in terms of comprising sensors and 15 arrays that can be used with or without detectable labels, it is important to understand that the term 'detectable labels' refers to labels as normally used in the art to detect a bound analyte through the use of chemical, radioactive and/or optical means. However, the present invention can use detectable labels which relate to aspects of the present invention. With regard to the present invention, a detectable label can be a molecule or 20 substance that is attached to a binding partner for an analyte of interest, or a binding partner which binds to an analyte of interest that adds a certain amount of additional mass to make the detection readily detected. Thus, a detectable label of the invention can be a label that adds a particular amount of additional molecular mass to a bound pair, or deposits, upon enzymatic reaction, a detectable amount of molecular 25 material to the surface of the substrate in response to a probe or a target that is bound thereon.

Sensor or sensor arrays of the present invention also can be used to determine known or unknown analytes in a sample using direct and indirect binding, competitive inhibition, sensitivity testing, specificity testing, affinity determination, and the like. 30 For example, indirect binding may be used when the amount of analyte that binds to the sensor membrane surface is too low for the sensor to detect. In this case, the sensor can be contacted with a sample containing a binding partner specific for the analyte bound to the sensor membrane. The sample-containing binding partner is preferably specific

for site on the analyte that is separate and non overlapping from the site bound by the membrane immobilized binding partner such that the two binding partners can be bound simultaneously to a single analyte molecule. Thus, indirect detection is achieved when the additional mass attributed to binding of the sample-containing binding partner to analyte on the membrane becomes detectable. Competitive inhibition may be used with a sensor or sensor array of the invention when an inhibitor analyte of lower mass inhibits binding of a larger mass analyte to the membrane.

In another aspect of the present invention, a method is provided for determining the presence or amount of an analyte in a sample. Exemplary steps of the method comprise; acquiring a sample presumed to contain an analyte to be detected, contacting the sample with a sensor or sensor array having a membrane that has a binding partner for the analyte immobilized on the surface, and determining the presence of the analyte in the sample based on a measured detectable change in membrane resonance or vibration. In a preferred embodiment the analyte to be detected and/or the binding partner of the analyte are not labeled and the sample is a liquid or gas.

In another aspect, the present invention provides a method for determining the rate of binding of a known amount of analyte in a sample to one more binding partners immobilized on separate sensor membranes of a sensor array. The method comprises contacting a sensor array of the invention with the sample and detecting a change in the membrane response over a period of time. In preferred embodiments, the rate of binding which occurs over time correlates to the rate constant of reaction between the analyte and its binding partner

In another aspect, the present invention provides a method for determining the affinity between an analyte and its binding partner, comprising contacting a sample containing a known concentration of the analyte with a sensor array of the invention wherein the sensor array comprises one or more sensor sites each with a membrane comprising a binding partner for the analyte. A change in the membrane response over a period of time is then detected. The bound analyte is then removed and the step of contacting and detecting with a sample repeated with a different concentration of the analyte. This cycle of removal, contacting with a different analyte concentration and measuring membrane response over time may be repeated multiple times, each with a different analyte concentration. The binding affinity between the analyte and its

binding partner can be derived by relating binding rate to analyte concentration in a manner well known to those of skill in the art.

While aspects and embodiments of the present invention are described herein, it would be understood that such descriptions are exemplary of uses and aspects of the presently described sensors and arrays and should not limiting in content.

DESCRIPTION OF DRAWINGS

FIG. 1a is perspective view of an embodiment of individual resonant micromechanical membrane sensor based on electrostatic capacitance.

FIG. 1b is a vertical cross-section of the sensor of FIG. 1 taken substantially along the line 1b – 1b of FIG 1.

FIG. 2 is a vertical cross-section of an embodiment of an individual resonant micromechanical membrane sensor based on electrostatic capacitance.

FIG. 3 is a vertical cross-section of an embodiment of an individual resonant micromechanical membrane sensor based on electrostatic capacitance.

FIG. 4 is a perspective view of the lower portion of an embodiment of a resonant micromechanical membrane sensor showing discrete concentric and sense electrodes (“dual port”).

FIG. 5a is a perspective view of an individual resonant micromechanical membrane sensor with electrostatic drive and piezoresistive sense.

FIG. 5b is a cross-section of the sensor of FIG 5a, taken substantially along the lines of 5b – 5b.

FIG. 6a is a perspective view of an individual resonant micromechanical membrane sensor with electrostatic drive and piezoelectric sense.

FIG. 6b is a cross-section of the sensor of FIG 6a, taken substantially along the lines of 6b – 6b.

FIG. 7 is a cross-section of an individual resonant micromechanical membrane sensor showing placement of a vertical lead from the planar electrode to the outside of the sensor.

FIG. 8 is a cross-section of an individual resonant micromechanical membrane sensor showing placement of a horizontal lead from the planar electrode to the outside of the sensor.

FIG. 9a is plan view of a resonant micromechanical membrane sensor array showing membrane, spacer layer and drive elements.

FIG. 9b is the underside of the resonant micromechanical membrane sensor array shown in FIG. 9a.

5 FIG. 10a is a graph of membrane sensitivity vs. thickness for 10-micron membrane in air.

FIG. 10b is a graph of membrane sensitivity vs. thickness for 10-micron membrane in water.

10 FIG. 11a is a graph of resonant membrane frequency in air as a function of membrane thickness and radius.

FIG. 11b is a graph of resonant membrane frequency in water as a function of membrane thickness and radius.

FIG. 12A-E depicts an approach for fabricating an individual micromachined resonant membrane sensor.

15 FIG. 13 is a schematic of a white noise/fft (Fast Fourier Transform) scheme.

FIG. 14 is a schematic of a phase locked loop.

FIG. 15a is a diagram of probes bound to an array.

FIG. 15b is a diagram of probes bound to single membrane of an individual micromachined resonant membrane sensor.

20 DETAILED DESCRIPTION

Individual Sensor Embodiments

The present invention provides a resonant micromechanical membrane sensor in both single and array formats that is sensitive to changes in the surface properties of the membrane surface such as density, inertia, viscous drag, or force. Measurement of a mass change using the sensors of the present invention is particularly suited for the detection of molecular interactions in a gas or liquid phase environment at the membrane surface of the sensor. A feature of the sensor is a drum-like cavity comprising a membrane at the top which contacts the environment to be sensed, or more walls that support the membrane, and a base with at least one electrode. The harmonic response of the device is sensitive to the surface properties of the membrane. The membrane also protects the drive elements within the cavity from direct contact

with the environment. The cavity also has other elements and various sensor embodiments will now be described in detail.

A resonant membrane sensor based on capacitive sensing is shown in FIGS. 1a and 1b. Referring to the figures, the single resonant membrane sensor 10 comprises a silicon wafer substrate 12, a membrane 18, a circular planar electrode 14 located within the substrate surface, and a spacer layer 16. The sensor cavity 22 comprises the resonating portion 28 of membrane 18, a circular sidewall 20 that is formed as an opening in spacer layer 16, and a base comprising the substrate 12 with planar electrode 14 formed thereon.

The spacer layer 16 can be made of any electrically insulating material with sufficient rigidity to maintain spacing between the membrane and planar electrode during membrane movement. The spacer layer can be prepared from silicon nitride, silicon dioxide, and the like.

Circular planar electrode 14 is formed within wafer 12 by diffusion or ion implantation. The sensor cavity 22 will generally have an air dielectric, although other dielectrics may also be utilized as application and design dictate. Lead 26 connects planar electrode 14 to a voltage source (not shown).

Membrane 18 (and resonating portion 28) can be prepared from electrically conductive material or non-conductive material. The membrane 18 is a continuous sheet formed across the entire surface of the sensor 10, the resonating portion 28 of membrane 18 is circular in shape. This occurs because the membrane is supported by a circular wall 20. The circular geometry of sensor membrane 18 distributes stress evenly and radially about the entire membrane eliminating points of high intrinsic stress and can offer preferably modes of oscillation as discussed herein. Choosing the proper mode of excitation involves designating a mode spaced sufficiently far from its neighbors such that cross mode interference does not occur, that sufficient amplitude is obtained and in which minimal damping occurs. Rectangular, square, or any other geometry may be used as fabrication or application dictates

Membrane 28 opposes planar electrode 14, form the opposing conducting plates or electrodes of a capacitor, separated by the cavity dialectic 22. Membrane 28 can be driven into resonance electrostatically by charging the planar electrode 14 with a variety of input functions such as sinusoids, square waves, saw tooth waves, triangle

waves, impulses, chirps, white noise, and the like. A dc-bias voltage also may be simultaneously applied to tune the mechanical and/or electrical response of the device. Membrane 18 and its resonating portion 28 can be grounded, preventing unwanted electrochemical interaction between charges at the sensor surface and the salts and biomolecules that may be present in test solutions. In an alternative, membrane 18 does not have to be grounded.

Decreasing nominal separation between planar electrode 14 and membrane 28 increases both the strength of electrostatic actuation and the output signal (i.e., increased capacitance). This increases sensitivity and decreases drive voltage requirements. In a preferred embodiment, the separation is between about 0.25 to 2 microns. Contact of membrane 28 to planar electrode 14 results in device failure, thus imposing a lower limit on separation.

The interior of cavity 22 is vented to outside atmosphere by passageway or holes 24 traversing electrode 14 and substrate 12. Venting eliminates pressure-related signal drift, such as long timescale barometric effects, by equilibrating internal cavity pressure with the outside atmosphere. Venting also minimizes short timescale pressure gradients across the membrane due to acoustic waves in the cavity. Vent surface area should be large enough to allow adequate airflow into and out of the cavity during operation yet must not compromise overall device performance (e.g., by impacting the area of the planar electrode 14). Although four holes are shown in FIG. 1, the number of holes and their diameter may vary with the characteristics of the sensor and its intended application. Venting may be eliminated entirely for some applications.

Resonant micromechanical membrane sensor 50 in FIG. 2 is similar overall to FIG. 1 but has a resonating membrane 56 that does not extend to the sides of the sensor, the figure showing minimal overlap with spacer layer 52 as compared to FIG. 1 where membrane 18 extends fully over the spacer layer 16.

Microfabricated resonant membrane sensor 60 in FIG. 3, is also similar to FIG. 1, but differs in having a layer 62 and having side walls 66 formed of the same material as the membrane 64, due to the conformal deposition of the membrane and the subsequent removal of a sacrificial layer from underneath the membrane resonating portion 68 compared to FIG. 1.

Capacitive detection of a resonating structure has advantages over approaches using piezoelectricity or piezoresistivity. For example, the simplest one-port device

for capacitive requires only a single electrode (see FIG. 1), while the simplest piezoelectric and piezoresistive devices require a minimum of two and three electrodes respectively and additional structures such as piezoresistors and piezoelectric transducers. Capacitive is more thermally stable than other transduction methods including piezoresistivity and piezoelectricity. It is less affected by temperature change than is piezoresistivity and piezoelectricity. The temperature coefficients of resistivity of common micromachining materials and pyroelectric constants of common piezoelectric materials can be quite high. Capacitors, however, exhibit extremely low temperature coefficients, are less noisy and more sensitive than piezoelectric and piezoresistive devices

Detection may also be accomplished through alternative means such as piezoelectricity, piezoresistivity, or optically when capacitive means are not optimal. One example for optical detection is provided in U.S. Patent Application Serial No. 09/812,111, filed March 15, 2001, entitled "Method for Monitoring the Oscillatory Characteristics of a Microfabricated Resonant Mass Sensor," and incorporated herein by reference as if fully set forth herein.

The present resonant micromechanical membrane sensor can be designed with a dedicated drive and sense electrode, separate from the resonating membrane. In reference to FIG. 4, the lower portion of the sensor 140 comprises substrate 142 with dual electrodes in a concentric design. In a non-limiting example the outer electrode 144 can provide actuation and inner electrode 146 can provide detection. Outer electrode 146 meets external voltage source at contact 156 via lead 154. Inner electrode 146 goes to detection circuitry via lead 148 and contact 150.

The concentric design of drive and sense electrodes in FIG. 4 provides optimal force and signal transduction. In operation, for example, a drive signal, such as a harmonically varying sinusoid with dc-offset, is applied through outer electrode 144. Magnitude of induced charge acquired at inner electrode 146 is affected by the displacement of the conductive resonating membrane of the sensor. Electrode geometry can also be varied to excite other modes of oscillation as desired. Separation between the concentric electrodes must be sufficient (and/or appropriate shielding used) to minimize stray fields and induced currents between the electrodes.

The present micromechanical sensor can be designed with electromechanical sense elements. In reference to FIG. 5, resonant membrane force sensor 160, overall

similar to the sensor in FIG. 1, comprises a “circular – shaped” piezoresistive sense element 166 that conforms to the outside border of circular-shaped resonating membrane 164, where maximum stress occurs during membrane oscillation.. The piezoresistive sense element 166 can be layered above the membrane 164 or fabricated within the membrane as shown. Sense element 166 can be prepared from doped silicon which has piezoresistive qualities. In this embodiment, membrane 166 is driven by electrostatic actuation (see discussion of FIG. 1) and membrane displacement measured through the changes in the resistance of the piezoresistive element 166. Change in resistance can be determined by incorporating 166 via connections 168 and 170 into a Wheatstone bridge assembly.

In reference to FIGS. 6a and 6b, substrate 202 with lower planar electrode 208 is the base of cavity 212 bounded on top by electrode 210 directly affixed below resonating membrane 204 and circular side wall 214. A thin ring of piezoelectric material 206, such as PVDF, PZT, or ZnO, deposited locally above and around the edges of the membrane 204 generates voltage when mechanically stressed by movement of membrane 206 during electrostatic actuation. By locating piezo-material 206 to the outside resonating edge of membrane 204 where stress is greatest, sensitivity loss from piezo-material mass and internal damping displacement is reduced and signal acquisition maximized.

A metal upper counter electrode 210 together with the doped lower electrode 208 provides the charged plates for electrostatic actuation. Membrane 206 can be surface micromachined from almost any material, including polysilicon, silicon nitride, silicon dioxide, and the like. The metal upper counter electrode 210 may be deposited on a sacrificial layer prior to deposition of membrane 204. Piezoelectric voltage may be measured using amplification and other techniques well known in the art. In the alternative a piezoelectric ring can be used for actuation of the sensor with capacitive detection.

Many approaches are possible for connecting the lower planar electrode to a voltage source or ground. In FIG. 7, micromachined resonant membrane sensor 280, planar electrode 284 connects at 288 to lead 286 which extend vertically through substrate 282 to emerge at contact 290. Alternatively, in FIG. 8, micromachined resonant membrane sensor 300, planar electrode 304 connects at 308 to lead 306 which extend horizontally through substrate 302 to emerge at contact 310.

To further simplify fabrication and operation, an alternative embodiment of the device utilizes electrostatic drive transducers and an external optical detection system. For example, the detection circuitry can be eliminated from the sensor and replaced with an optical sensor such as a laser Doppler vibrometer ("LDV"). LDV measures the oscillatory characteristics of the resonating membrane by the effect of the membrane on the laser beam. U.S. Patent Application Serial No. 09/812,111, filed March 15, 2001, entitled "Method for Monitoring the Oscillatory Characteristics of a Microfabricated Resonant Mass Sensor," and incorporated herein by reference as if fully set forth herein, exemplifies the details of using a Laser Doppler Vibrometer as a detection scheme in resonant mass sensors. Other interferometers such as Michelson or stroboscopic interferometers may also be used for this purpose.

Sensor Array Embodiments

The present invention includes a micromechanical resonant membrane sensor array, which has various features of the individual sensor embodiments described above. The sensors are microfabricated to have nominally similar resonant frequencies and performance characteristics except possibly in the case where the sensor unit is used as a reference. Each sensor in the array needs to be spaced an appropriate distance from its nearest neighbors or appropriately isolated so that mechanical, acoustical, and electrical cross-talk do not substantially propagate to the adjacent sensor sites.

In one embodiment, sensor array 400 shown in FIGS. 9a and 9b comprises 12 separate sensor sites or units 414 similar in design to the individual sensor unit shown in FIG. 1. Sensor array 400 comprises a silicon substrate 410 into which the individual planar electrodes 416 are formed. Membrane 422 shown at the lower left in FIG. 9a covers the entire substrate 412. The resonating membrane 424, above the sensor cavity (not shown), is part of membrane 422. Spacer layer 425 shown at lower left is situated below membrane 422 and above substrate 412. The membrane 422 functions as both a resonant element 424 and a barrier to isolate sample fluid from contacting the drive elements 414. Membrane layer 422 is fabricated of electrically conductive material and preferably as a single continuous layer covering all the sensors in the array:

The resonating membrane for each sensor 424 is grounded by membrane 422 contacting grounding strip 426 which has connecting leads 428. Grounding of the exposed membrane surface 422 prevents unwanted electrochemical interaction between

charges at the sensor surface and the salts and biomolecules in test solutions. A common ground also reduces the number of discrete interconnects necessary to address each sensor, which increases the number of channels available for parallel actuation and detection the entire array. In another embodiment discrete grounds may be used or
5 the membranes may not be grounded..

In sensor array 410, each sensor can be separately interrogated by having a separate drive lead electrically isolated from the other sensors. As seen in FIG. 9a, electrical isolation of each sensor unit is accomplished 420, which represents a non-conducting border material or a channel. FIGS. 9a and 9b together show how the
10 individual sensors can have separate drive connections allowing individual sensor actuation and sensing. In this regard, FIG. 9a shows planar electrode 416 having lead 418, which extends downwards into the substrate, emerging on the substrate 410 bottom side (418 in FIG. 9b). The unique position of each contact point 418 allows for a separate connection to a voltage source. Instead of individual sensor interrogation,
15 one skilled in the art would understand that groups of sensors can be multiplexed such that a discrete number of individual sensors may be simultaneously interrogated and the response simultaneously measured.

Specific sensors sites in the array can be designed or designated as a reference site. A reference site is a sensor in the array that generates a control value to which
20 sensors that measure unknown are compared and extraneous variables, such as temperature, fluctuations in pressure, environmental vibrations can be eliminated. Sensitivity can be increased by using reference sensor sites. Various types of reference sensors are contemplated. For example, a reference sensor may be a sensor where the membrane is fixed in position as a fixed plate capacitor such as when a non-conductive
25 dielectric support 430 is inserted into an otherwise functioning sensor cavity. Support 430 may be prepared from silicon dioxide, silicon nitride and the like. Other approaches also would be apparent to one of ordinary skill in the art. In the case of detecting chemical or biological compounds from a gas or liquid environment, reference sites may also include be mechanically active sensors that are chemically
30 inactive, for example the sensor does not bind a compound of interest. Other reference sensor sites are possible and known to those of skill in the art.

Determining Membrane Dimensions

Membrane dimensions are dictated by a number of parameters, primarily the desire to decrease damping, increase device sensitivity, and the practical limits of fabrication.

5 Damping in acoustical MEMS-based sensors is present in four major forms: internal material damping, assembly damping, viscous damping and acoustic damping. The effects of damping are to decrease device Q, decrease efficiency, and ultimately decrease sensitivity. Among the four main contributors of damping, acoustic damping is the dominant form of energy dissipation. Thus, membrane size is driven primarily by
10 the need to reduce acoustic radiation.

 When a resonating membrane sensor contacts a fluid environment, the amount of acoustic propagation into the fluid and the degree of acoustic coupling between the fluid and the membrane relates to the acoustic wavelength of the surrounding medium at the operating frequency and the membrane size. While acoustic propagation can
15 occur normal to the membrane surface, acoustic damping may still be minimized by ensuring that membrane diameter is always significantly smaller than the acoustic wavelength of the immersion fluid at the operating frequency. Driving a membrane in its fundamental mode will result in maximal signal amplitude and minimal damping because the lower order modes have larger displacements, lower resonant frequencies,
20 and hence longer acoustic wavelengths. Optimal membrane radii range from 2.5 to 50 microns. For these radii, the acoustic wavelength is smaller than the membrane radius while operating in the fundamental mode.

 Other modes of resonance may also be utilized. In some cases, the higher order modes may increase device Q by offsetting inertial effects and creating balanced modes
25 of oscillation and/or by reducing acoustic propagation by self-canceling of the acoustic waves generated in the medium.

 Internal material damping and assembly damping may be minimized by proper material choice and device design. Single crystal silicon is an excellent mechanical material due to its high Young's modulus, low internal damping, zero residual stress,
30 and low coefficient of thermal expansion. This leads to devices with high mechanical Q's and reliable operation. By eliminating features such as contacting or friction

surfaces, assembly damping may also be minimized. Viscous damping is a small contributor of damping in relatively inviscid fluids such as water.

Since membrane resonant frequency is highly dependant on the membrane radius, membrane size is also limited by the desired operating frequencies. The optimal
 5 operating frequencies from mechanical and electrical standpoints lie in the kHz to low MHz range. Above the low MHz range, signal processing components become increasingly costly and complex and acoustic damping becomes a major factor. At low frequencies, electrical 1/f noise dominates and frequency shifts become difficult to detect.

10 Resonant membrane thickness is controlled by the desired device sensitivity and fabrication limits. The membrane behaves in a manner similar to a simple harmonic oscillator. Mass loading of membrane surface increases the effective mass of the oscillator and decreases the resonant frequency of the membrane. Device sensitivity can be defined as the fractional change in resonant frequency divided by the
 15 incremental increase in surface mass. Algebraic rearrangement gives

$$S_m = \frac{\Delta f / F_o}{\Delta m} = -\frac{1}{2M} = -\frac{1}{2\rho t}$$

where Δf is the mass-loaded resonant frequency shift, F_o is the unloaded resonant frequency, Δm is the mass per unit area of the added mass, M is the areal mass density, ρ is the membrane density, and t is the membrane thickness 25. Thinner membranes
 20 give rise to increased sensitivity but practical fabrication limitations sets membrane thickness to a minimum of 0.1-0.5 microns.

In the presence of fluid, an additional mass must be added to compensate for mass loading due to the presence of fluid. This mass of water can be approximated as a sphere with a radius equal to that of the membrane. The sensitivity then becomes

$$25 \quad S_m = \frac{\Delta f / F_o}{\Delta m} = -\frac{1}{2(\rho t + \frac{4}{3}\pi r \rho_w)}$$

where r is the radius, ρ_w is the density of the fluid and $M=\rho t$. Sensitivity shows a direct correlation to thickness. This is due to the inertia of the plate. In fluid, thickness of the membrane has a decreased effect since the mass-loading effect of the fluid dominates.

FIGS. 10a and 10b graphically illustrate the relationship between sensitivity and

thickness for a 10-micron radius Si membrane in air and water, respectively. FIGS. 11a and 11b graphically illustrate resonant frequency achieved in air and water, respectively, as a function of membrane thickness and membrane radius. The results indicate that small and thin membranes minimize damping and inertia. A membrane thickness of about 0.1 to 0.5 microns and a membrane radius of about 2.5 to 50 microns is preferred.

Fabrication of Preferred Embodiments

Various approaches may be used for to fabricate a resonant micromachine membrane sensor of the invention. One approach is shown in FIG. 12a – 12f. A p-type, FZ silicon wafer with a resistivity of $>10,000$ ohm cm is used as the substrate 82 and electrode 84 and lead 86 are ion implanted at high energy and high dose to a depth of 0.5 μm and surface concentration of 1×10^{16} ions/cm². A 1 micron wet thermal [silicon dioxide] oxide layer 84 is grown and then patterned with a wet etch to define the spacer layer 88 of about 1 micron in thickness 2000Å of silicon dioxide is left un-etched as a subsequent etch stop. A backside align, pattern, and DRIE (deep reactive ion etching) is used to form vent holes 90 extending entirely through the material substrate 82 and electrode 84. The sensor membrane is formed using a silicon-on-insulator (“SOI”) wafer 92, which comprises a silicon “handle” layer 94, an intermediate layer of silicon dioxide or “box oxide” 96 and a layer of silicon 98. The silicon layer 98 side of SOI wafer 92 is fusion bonded to patterned spacer layer 88. The handle wafer 94 and the “box” oxide layer 96 are removed by a wet etch, leaving a membrane layer 100 (shown in exaggerated size). Finally, vias are etched in the remaining oxide and metal is patterned to form the final leads to the electrodes and contact pads (not shown). Trenches or channels can also be etched to physically and electrically separate the membrane or to separate the sensors from each other in an array. Other types of silicon wafers can be used in this process including a double polished p-type silicon wafer.

In another approach, a 4” Si, DSP thin silicon wafer, either p- or n-type is used as the substrate. 1 μm of wet thermal oxide is grown to passivate the wafer. 2000Å of a high temperature metal such as titanium, tungsten or a titanium-tungsten composite is deposited onto the surface and patterned to form electrodes and leads. Vias are then etched into both the metal and oxide layers straight down to the substrate. Next a 1.5 μm layer of LTO or phosphosilicate glass (PSG) is deposited by low pressure chemical

vapor deposition ("LPCVD"). A subsequent backside align, pattern, and DRIE is used to form the vent holes. A CMP step is used to planarize the LTO surface and reduce the surface roughness to a magnitude favorable to bonding. After CMP, the oxide layer is patterned with a wet etch to define the spacer layer and the membrane formed from an SOI wafer as described in the first approach.

Fabrication of a surface micromachined silicon nitride membrane sensor is detailed as follows. Electrodes and lead lines are diffused into a double-sided polished thin wafer using either thermal diffusion or ion implantation. A thermal oxide layer is then grown to act as an insulator and etch stop. A polysilicon sacrificial layer is deposited using LPCVD or similar technique such as PECVD. A second conformal tungsten electrode is then deposited over the polysilicon layer and over vias to the lead lines formed earlier. The membrane is formed by depositing low temperature oxide (LTO) and/or low stress nitride (LSN) over the tungsten electrode and polysilicon spacer layer. Vents are etched from the backside of the wafer using DRIE. Finally, the sacrificial polysilicon is removed, and the membrane released by a vapor phase XeF_2 etch process that isotropically removes silicon but is extremely selective to silicon dioxide and certain metals, such as for example aluminum.

The planar electrode may be fabricated by diffusion or ion implantation of silicon doped with either boron or phosphorus. A doped electrode of high impurity concentrations is useful to minimize electrical resistance. In alternative embodiments, electrodes may be patterned by metal deposition using techniques such as evaporation, sputtering, or electroplating. Diffused electrodes can withstand higher processing temperatures and harsher processing conditions than their metal counterparts and are preferred in many applications. However, they typically have significantly higher electrical impedance's that can lead to increased parasitic capacitance and signal degradation. In applications where high sensitivity is required, metal electrodes and leads may be preferred.

The above processes serve merely as examples of fabrication that are among the many methods of microfabrication that can be used to form devices of the invention. Further details can be found among membrane-based pressure sensors and accelerometers. Due to the parallel nature of microfabrication processes, these techniques can be readily extended to microfabricate an array having many sensors as described herein.

Modes of Operation of Preferred Embodiments

With reference to FIG. 13, in a preferred embodiment, electrostatic actuation and capacitive detection are employed. Each site in the sensor 111 is driven into resonance by white noise source 110 applied through the lower electrode. As a result, the membrane oscillates primarily in its fundamental mode. Applying a constant voltage induces current in the electrode that is proportional to the membrane impedance. At mechanical resonance, the current component of the oscillation signal should be a maximum. A band-pass filter 111 can be used to limit bandwidth. Fast Fourier analysis 113 of the current signal produces peaks that can be used to identify the resonant response of the system. A constant current can also be applied to the membrane, and the resultant voltages that are developed can be measured. Differential measurements performed between derivatized sites and chemically inactive sites can be used to compensate for temperature-induced drift, non-specific adsorption, or noise due to external vibrations, etc.

With reference to FIG. 14, in an alternative mode of excitation and detection, the sensor 120 is incorporated as part of a phase-locked loop (PLL) 126. A feedback-loop circuit 126 incorporating a phase comparator 123 sustains resonance of the device 120 by locking on to the frequency at which a 90-degree phase shift is maintained between the drive signal and the output signal. The output signal passes through a low-pass filter 121 to an amplifier 122 and then a phase comparator 123. The phase comparator 123 adjusts the frequency of the voltage-controlled oscillator 124 such that the frequencies of the input and output signals match. Monitoring the frequency at which the PLL 126 is locked with a frequency counter 125 provides a method a continuously monitoring the resonant frequency.

In a yet alternative mode of excitation and detection, harmonic sweeps of the excitation signal through frequencies nominally bounding the resonant frequency are performed. Ratiometric analysis of voltage division between a test site and a fixed plate reference capacitor can be used to perform differential measurements to decrease the effects of parasitic capacitances, electronic noise, and drift. Phase information can also be utilized to identify resonant peaks.

In a further embodiment, the prior device is integrated as part of a tunable oscillator circuit. The electrical characteristics of the circuit can be monitored to obtain

gain-phase information and device impedance data. Tunable oscillator circuits provide a simple, inexpensive means of maintaining resonant oscillations and when combined with further circuitry such as sustaining amplifiers or automatic gain control loops, can act as means for accurately exciting and monitoring resonant elements.

5 The previous descriptions are meant to illustrate but not limit the multiple modes of operation that can be utilized with a single device. For example, similar variations of the above schemes, with the proper adjustments, can be applied to alternative devices with any combination electrostatic, piezoelectric, or acoustic excitation and capacitive, piezoelectric, piezoresistive, or optical detection.

10 Applications of Preferred Embodiments

 The array of sensors is designed to operate with a parallel array of molecular probes. Each site within the array can be derivatized with a different molecular probe such that the device becomes potentially chemically responsive to sample solutions. A binding event between a substance in a sample solution and a molecular probe results in
15 an increase of the surface mass of the membrane and a corresponding decrease in resonant frequency or vibration. Screening is designed to be performed under wet conditions and does not necessitate drying of the chip. Doing so could alter the chemical reactivity of the involved species, cause denaturing, conformational changes, or instabilities in the substances, and create problems such as the precipitation of salt
20 from solution. For further application details, refer to U.S. Patent No. 5,912,181 entitled "Method for Molecular Detection Utilizing Digital Micromirror Technology." Chemical binding constants and affinity can be determined by titration of the sample solution over the device and real-time monitoring of resonant frequency shifts as a function of concentration. The chip is also robust enough to be reusable such that
25 multiple samples can be serially flowed over the chip and screened in sequence.

 With reference to FIG. 15, an application where such an array would be useful is in pharmaceutical high throughput screening (HTS). Activity of a molecule such as a receptor or enzyme against an entire combinatorial library 130 can be performed in parallel. Each member of the library 131 would be chemical bound to an individual
30 membrane 132. A solution containing the molecule is passed over the entire chip. "Hits" are identified by locating the sites that displayed mass-induced resonant frequency shifts. Multiple screenings of various molecules against the same library 131

can be performed on a single derivatized chip by sequentially flowing various test solutions containing the desired molecules and wash solutions over the chip. Binding constants of hits can also be measured by titration of samples.

Both individual sensors and sensor arrays can be used for a variety of applications. This includes immobilizing a binding partner such as a peptide, small molecule drug on the sensor and testing for binding to a protein source such as human serum, or immobilizing an array of binding partners and screening a phage display library in solution. Another use is to immobilize nucleic acid on the sensor membrane and then screen a solution analytes that might be transcriptional factors such as activators or repressors. Alternatively, transcription factors may be immobilized to a sensor and evaluated for their ability to bind DNA or small molecules. The sensors also can be used to identify and characterize protein – protein interactions. This may include specificity and affinity determination and involve screening antibodies, drugs, determining binding between intracellular mediators, lectin-lectin interactions, cell substrate interactions, virus life cycle relevant interactions such as integrase – nucleic acid binding, capsid protein – capsid protein binding (i.e., viral assembly) and mRNA – protein binding (i.e., viral translational regulation). In another approach, small molecule compounds such as drugs, mimetics, peptides can be immobilized to the membrane and the sensor tested for binding to a natural ligand.

While preferred embodiments and methods have been shown and described, it will be apparent to one of ordinary skill in the art that numerous alterations may be made without departing from the spirit or scope of the invention. Therefore, the invention is not limited except in accordance with the following claims.

We Claim:

1. A micromechanical sensor comprising a membrane for detecting a change in the force or membrane surface properties, said sensor comprising:
 - a substrate; and
 - 5 one or more layers on or in said substrate, said one or more layers forming a cavity or said substrate and said one or more layers forming a cavity,
 - said cavity comprising:
 - one or more side walls;
 - 10 a membrane covering the top of said cavity, said membrane providing a substantial barrier to liquid entry through the top of said cavity; and
 - at least two electrodes, wherein an upper electrode is the membrane or is fabricated on, within or below the membrane and a lower electrode below the membrane, wherein said membrane composition and
 - 15 dimension enables said membrane to vibrate or resonate in response to changes in electrical signal in said lower electrode, and wherein said change in force or membrane surface properties are detected by the sensor as an alteration of the membrane response.
2. The sensor of claim 1, wherein said cavity is substantially liquid free
- 20 3. The sensor of claim 1, wherein said force is pressure.
4. The sensor of claim 1, wherein said membrane surface property change is an increase in mass associated with the membrane.
5. The sensor of claim 4, wherein said increase in mass results from a binding event on said membrane.
- 25 6. The sensor of claim 5, wherein said binding event is between an analyte in solution or in a gas and a binding partner immobilized on the sensor membrane.
7. The sensor of claim 1, wherein said substrate comprises one or more materials selected from the group consisting of; single crystal silicon, glass, gallium arsenide, silicon-on-insulator, silicon-on-sapphire, and indium phosphate.
- 30 8. The sensor of claim 1, wherein said one or more layers comprise one or more materials selected from the group consisting of: single crystal silicon, polysilicon,

silicon nitride, silicon dioxide, phosphosilicate glass, borophosphosilicate glass, aluminum nitride, zinc oxide, polyvinylidene fluoride, lead zirconate, and metal.

9. The sensor of claim 1, wherein said one or more layers comprise materials having different electrical properties.

5 10. The sensor of claim 1, wherein said substrate comprises a P-type silicon wafer having a resistance rating between 5 and 15,000 Ω ·cm.

11. The sensor of claim 10, wherein said resistance rating is 10,000 Ω ·cm.

12. The sensor of claim 1, wherein said membrane is circular in shape.

10 13. The sensor of claim 12, wherein said membrane has a radii of between 2.5 to 50 microns.

14. The sensor of claim 1, wherein said membrane has a thickness of between at least .05 and .5 microns.

15. The sensor of claim 1, wherein said membrane is polygonal in shape.

15 16. The sensor of claim 15, wherein the membrane has a length of between 5 to 100 microns.

17. The sensor of claim 1, wherein said one or more side walls have a height of between 0.1 to 2 microns.

20 18. The sensor of claim 1, wherein said membrane comprises one or more of; single crystal silicon, polysilicon, silicon nitride, phosphosilicate glass, borosilicate glass, silicon dioxide, aluminum nitride, zinc oxide, polyvinylidene fluoride, lead zirconate, or metal.

19. The sensor of claim 1, wherein said cavity has a depth of between 0.1 to 2 microns.

25 20. The sensor of claim 1, wherein said cavity has a depth of between 0.3 to 1 micron.

21. The sensor of claim 1, wherein said cavity comprises one or more vents connecting said cavity to the exterior of said sensor.

22. The sensor of claim 1, wherein the cavity comprises one or more dielectric materials.

30 23. The sensor of claim 22, wherein said dielectric materials are selected from the group consisting of; tantalum, polypropylene film, polymer-aluminum,

polyester, metalized polyester, plastic foam sheet, transformer oils, paraffin, gas, argon, oxygen, and chlorine.

24. The sensor of claim 1, wherein said cavity comprises an interior inert ambient atmosphere.

5 25. The sensor of claim 1, wherein said cavity comprises a vacuum.

26. The sensor of claim 1, wherein said two or more electrodes comprise a material selected from the group consisting of; p-doped silicon, n-doped silicon, metal alloy, titanium, gold, aluminum, and tungsten.

27. The sensor of claim 1, wherein said upper electrode is the membrane.

10 28. The sensor of claim 1 wherein said two or more electrodes comprises an upper electrode and two lower electrodes, wherein one lower electrode is a actuation electrode and the other lower electrode is a detection electrode.

29. The micromechanical sensor of claim 1, wherein said membrane comprises a binding partner that binds an analyte.

15 30. The sensor of claim 29, wherein said binding partner is selected from the group consisting of; antibodies, antigens, nucleic acid molecules natural DNA, RNA, gDNA, cDNA, mRNA, tRNA, synthetic DNA, RNA, gDNA, cDNA, mRNA, tRNA, lectins, sugars, oligosaccharides, glycoproteins, receptors, growth factors, cytokines, small molecules, peptide library, natural products library, a legacy library, a
20 combinatorial library, an oligosaccharide library, a phage display library, metabolites, drugs of abuse, metabolic by-products of drugs of abuse, enzyme substrates, enzyme inhibitors, enzyme co-factors, vitamins, lipids, steroids, metals, oxygen, gases found in physiologic fluids, cells, cellular constituents, cell membranes, associated cell structures, cell adhesion molecules, plant products, animal products, and tumor
25 markers.

31. The sensor of claim 1, wherein said membrane further comprises one or more piezoresistive elements, wherein said response of said membrane to said change is force or membrane surface properties is measured through a change in the resistance of said one or more piezoresistive elements.

30 32. The sensor of claim 1, wherein said membrane further comprises one or more piezoelectric elements capable of producing an output voltage, and wherein said response of said membrane to said change is force or membrane surface properties is

measured through a change in output current from said one or more piezoelectric elements.

33. A sensor array comprising a plurality of micromechanical sensor sites, said sensor sites comprising a membrane for detecting a change in force or membrane surface properties, each sensor site comprising:
- 5 a substrate; and
one or more layers on or in said substrate, said one or more layers forming a cavity or said substrate and said one or more layers forming a cavity, said cavity comprising:
- 10 one or more side walls;
a membrane covering the top of said cavity, said membrane providing a substantial barrier to liquid entry through the top of said cavity; and
at least two electrodes, wherein an upper electrode is the membrane or is attached to the membrane and a lower electrode below the
- 15 membrane, wherein said membrane composition and dimension enables said membrane to vibrate or resonate in response to changes in electrical current in said lower electrode, and wherein said change in force or surface membrane properties is detected by the sensor as an alteration of the membrane response.
34. The sensor array of claim 33, wherein said cavity of each sensor is
- 20 substantially liquid free
35. The sensor array of claim 33, wherein said force is pressure.
36. The sensor array of claim 33, wherein said membrane surface change is an increase in mass associated with the membrane.
37. The sensor array of claim 33, wherein said increase in mass results from
- 25 a binding event on said membrane.
38. The sensor array of claim 37, wherein said binding event is between an analyte in solution or in a gas and a binding partner immobilized on the sensor membrane.
39. The sensor array of claim 33, wherein said substrate comprises one or
- 30 more materials selected from the group consisting of; single crystal silicon, glass, gallium arsenide, silicon insulator, silicon-on-sapphire, and indium phosphate.

40. The sensor of claim 33, wherein said one or more layers comprise one or more materials selected from the group consisting of: single crystal silicon, polysilicon, silicon nitride, silicon dioxide, phosphosilicate glass, borophosphosilicate glass, aluminum nitride, zinc oxide, polyvinylidene fluoride, lead zirconate, and metal.
- 5 41. The sensor array of claim 33, wherein said one or more layers comprise materials having different electrical resistance properties.
42. The sensor array of claim 33, wherein said substrate comprises a P-type silicon wafer having a resistance rating between 5 and 15,000 Ω ·cm.
43. The sensor array of claim 42, wherein said resistance rating is
10 10,000 Ω ·cm.
44. The sensor array of claim 33, wherein said membrane is circular in shape.
45. The sensor array of claim 44, wherein said membrane has a radius of between 2.5 to 50 microns.
- 15 46. The sensor array of claim 33, wherein said membrane has a thickness between at least .05 and .5 microns.
47. The sensor array of claim 33, wherein said membrane is polygonal in shape.
48. The sensor array of claim 47, wherein the membrane has a length of
20 between 5 to 100 microns.
49. The sensor array of claim 33, wherein said one or more side walls have a height of between 0.1 to 2 microns.
50. The sensor array of claim 33, wherein said membrane comprises one or more of; single crystal silicon, polysilicon, silicon nitride, phosphosilicate glass,
25 borosilicate glass, silicon dioxide, aluminum nitride, zinc oxide, polyvinylidene fluoride, lead zirconate, or metal.
51. The sensor array of claim 33, wherein said cavity has a depth of between 0.1 to 2 microns.
52. The sensor array of claim 33, wherein said cavity has a depth of between
30 0.3 to 1 micron.
53. The sensor array of claim 33, wherein said cavity comprises one or more vents connecting said cavity to the exterior of said sensor.

54. The sensor array of claim 33, wherein the cavity comprises one or more dielectric materials.

55. The sensor array of claim 54, wherein said dielectric materials are selected from the group consisting of; tantalum, polypropylene film, polymer-
5 aluminum, polyester, metalized polyester, plastic foam sheet, transformer oils, paraffin, gas, argon, oxygen, and chlorine.

56. The sensor array of claim 33, wherein said cavity comprises an interior inert ambient atmosphere.

57. The sensor array of claim 33, wherein said cavity comprises a vacuum.

10 58. The sensor array of claim 33, wherein said two or more electrodes comprise a material selected from the group consisting of; boron, phosphorus, metal alloy, titanium and tungsten.

59. The sensor array of claim 33, wherein said upper electrode is the membrane.

15 60. The sensor array of claim 33 wherein said two or more electrodes comprises an upper electrode and two lower electrodes, wherein one lower electrode is a actuation electrode and the other lower electrode is a detection electrode.

61. The sensor array of claim 33, wherein said membrane comprises a binding partner that binds an analyte.

20 62. The sensor array of claim 61, wherein said binding partner is selected from the group consisting of; antibodies, antigens, nucleic acid molecules natural DNA, RNA, gDNA, cDNA, mRNA, tRNA, synthetic DNA, RNA, gDNA, cDNA, mRNA, tRNA, lectins, sugars, oligosaccharides, glycoproteins, receptors, growth factors, cytokines, small molecules, peptide library, natural products library, a legacy library, a
25 combinatorial library, an oligosaccharide library, a phage display library, metabolites, drugs of abuse, metabolic by-products of drugs of abuse, enzyme substrates, enzyme inhibitors, enzyme co-factors, vitamins, lipids, steroids, metals, oxygen, gases found in physiologic fluids, cells, cellular constituents, cell membranes, associated cell structures, cell adhesion molecules, plant products, animal products, and tumor
30 markers.

63. The sensor array of claim 33, wherein said membrane further comprises a one or more piezoresistive elements, wherein said response of said membrane to said

change is force or membrane surface properties is measured through a change in the resistance of said one or more piezoresistive elements.

64. The sensor array of claim 33, wherein said membrane further comprises one or more piezoelectric elements capable of producing an output current, and wherein
5 said response of said membrane to said change is force or membrane surface properties is measured through a change in output voltage from said one or more piezoelectric elements.

65. The sensor array of claim 33, further comprising one or more reference sensor sites.

10 66. The sensor array of claim 33, wherein each of said sensor sites is individually addressable.

67. The sensor array of claim 33, wherein multiple sensor sites are simultaneously addressable.

15 68. A method for detecting the presence of an analyte suspected of being present in a sample, comprising:

contacting the sensor of claim 1 with the sample and detecting a change in the membrane response, wherein said sensor membrane comprises a binding partner for the analyte.

20 69. The method of claim 68, wherein said analyte and binding partner are selected from the group consisting of; ligand/receptor, antigen/antibody, enzyme/substrate, DNA/DNA, DNA/RNA, or RNA/RNA, nucleic acid/protein.

70. The method of claim 68 wherein membrane response is determined over a period of time.

25 71. A method for detecting the presence of an analyte suspected of being present in a sample, comprising:

contacting the sensor array of claim 33 with the sample and detecting a change in the membrane response of at least one sensor site, wherein said membrane of said at least one sensor site comprises a binding partner for the analyte.

30 72. The method of claim 71 wherein said membrane response is determined over a period of time.

73. The method of claim 71 wherein said array further comprises one or more reference sensor sites.

74. A method for determining the rate of binding of a known amount of analyte in a sample to one more binding partners immobilized on separate sensor membranes of a sensor array, comprising:

contacting the sensor array of claim 33 with the sample and detecting a change in the membrane response over a period of time.

75. The method of claim 74, wherein the rate of binding correlates to the rate constant of reaction between the analyte and binding partner.

76. A method for determining the rate of binding of an analyte in a sample to a plurality of binding partners each immobilized on separate sensor membranes of a sensor array, comprising:

contacting the sensor array of claim 33 with the sample and detecting a change in the membrane response over a period of time.

77. A method for determining the affinity between an analyte and binding partner, comprising the steps of:

contacting the sensor array of claim 33 wherein said sensor array comprises one or more sensor sites each with a membrane comprising said binding partner with a sample containing a known concentration of said analyte and detecting a change in the membrane response over a period of time,

removing analyte bound to said sensor and repeating said contacting and detecting with a sample containing a different concentration of said analyte,

wherein the affinity is determined by comparing the amount of binding to the concentration of analyte in the sample.

FIG. 1a

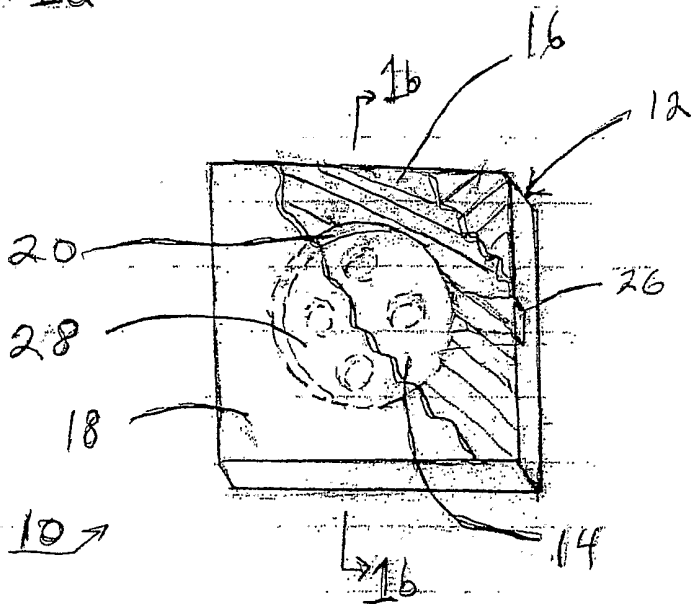

FIG. 1b

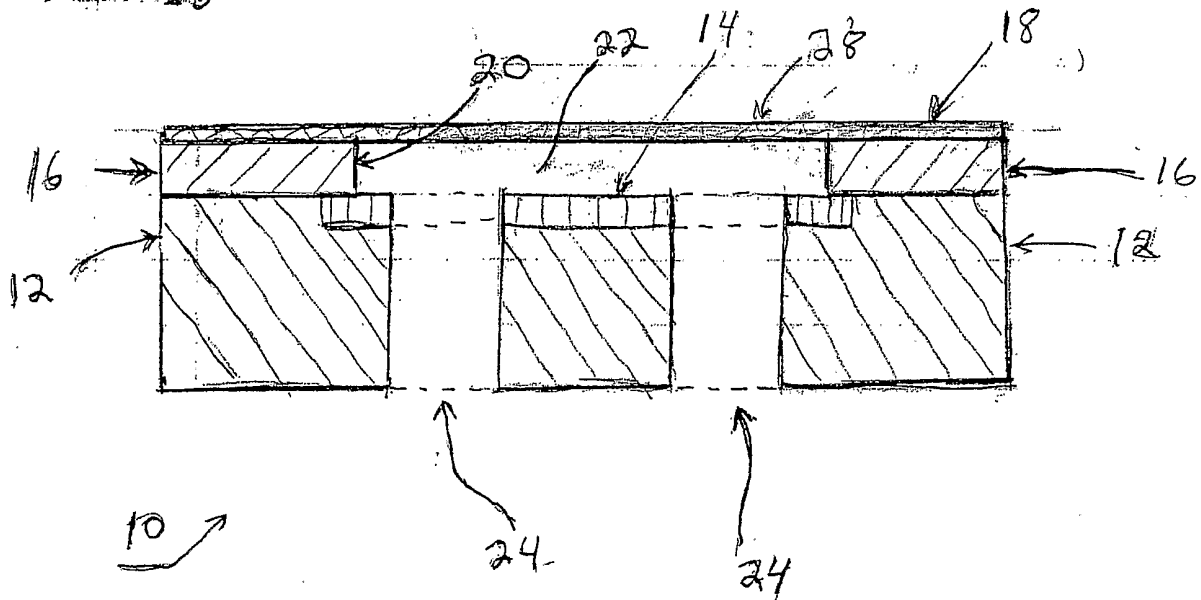
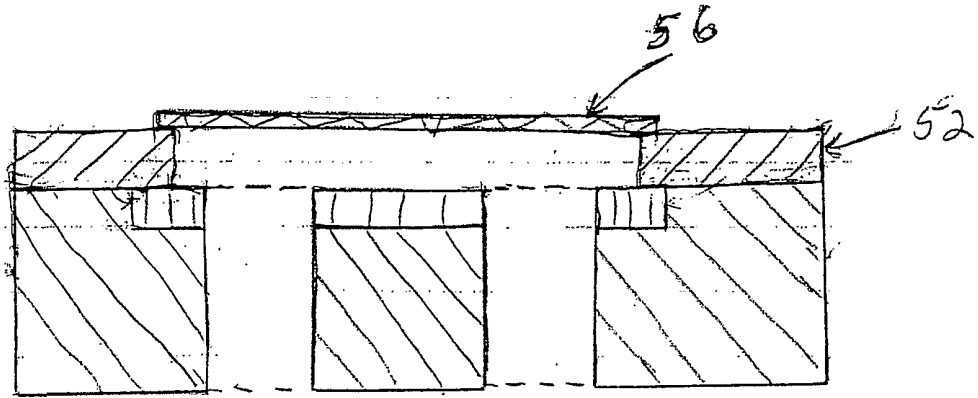
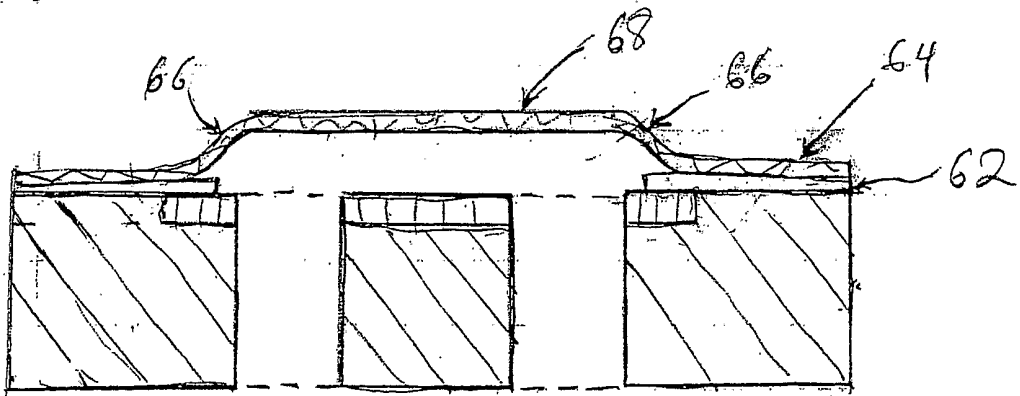

FIG. 2



50 →

FIG. 3



60 →

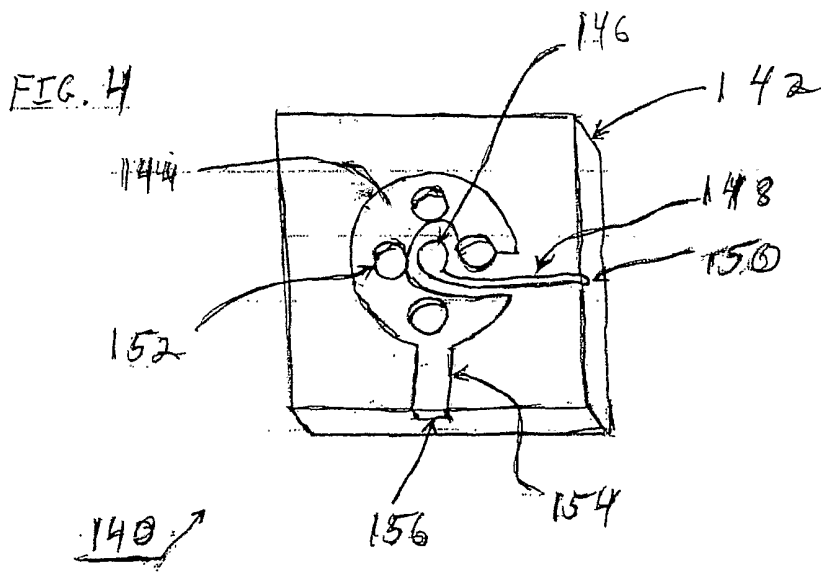

FIG. 5a

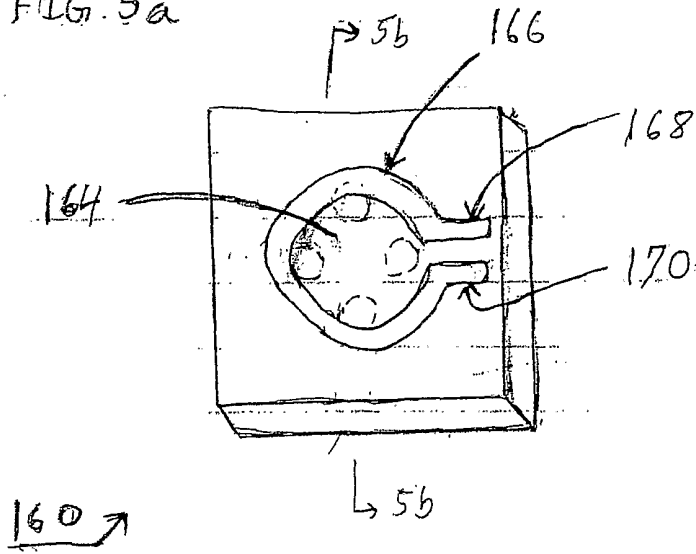

FIG. 5b

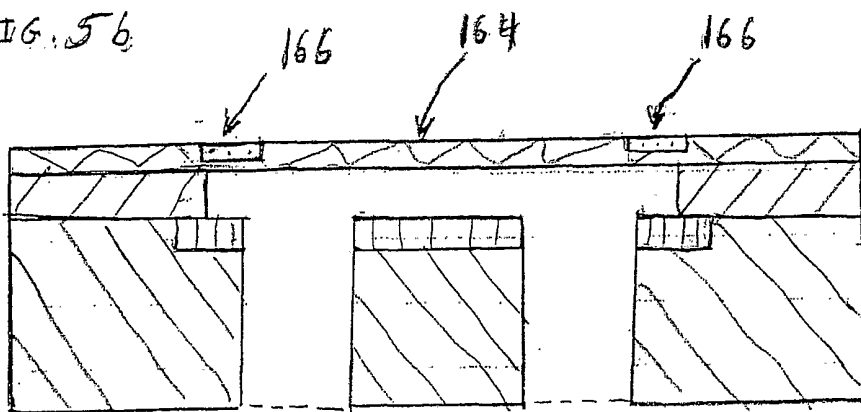
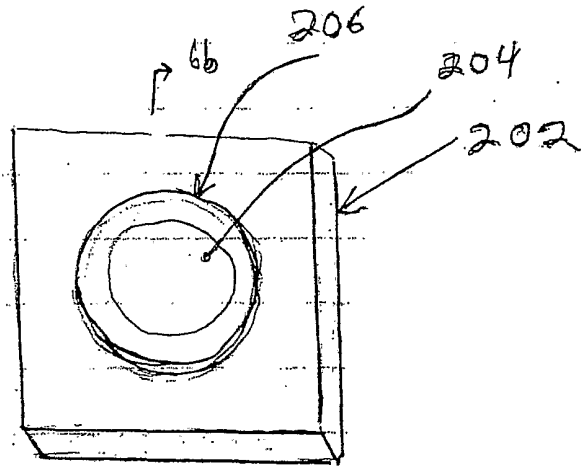

FIG 6a



200 ↗

↳ 66

FIG 6b

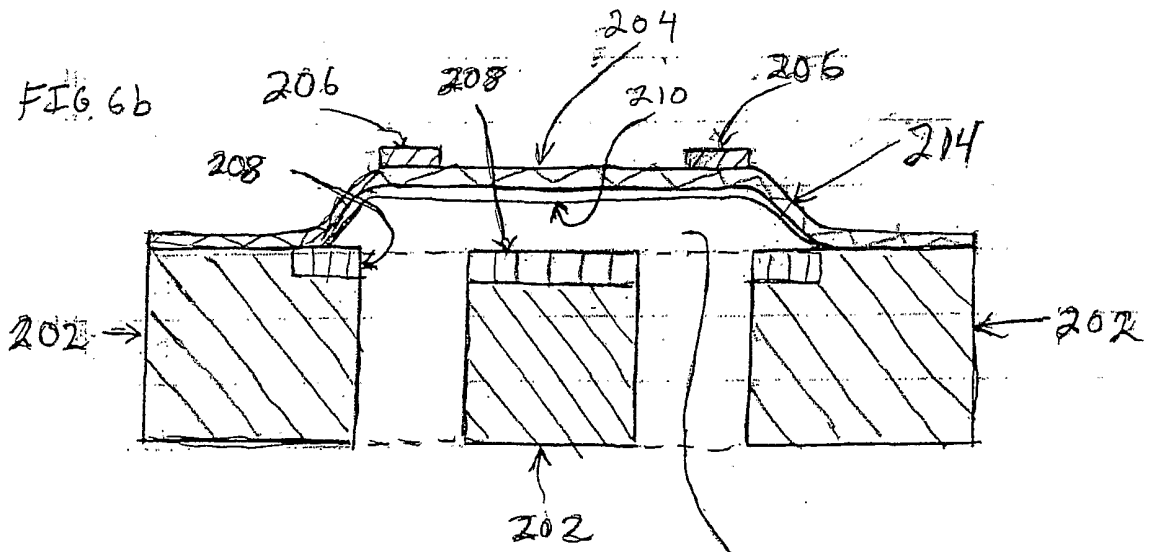

200 ↗

212

FIG. 7

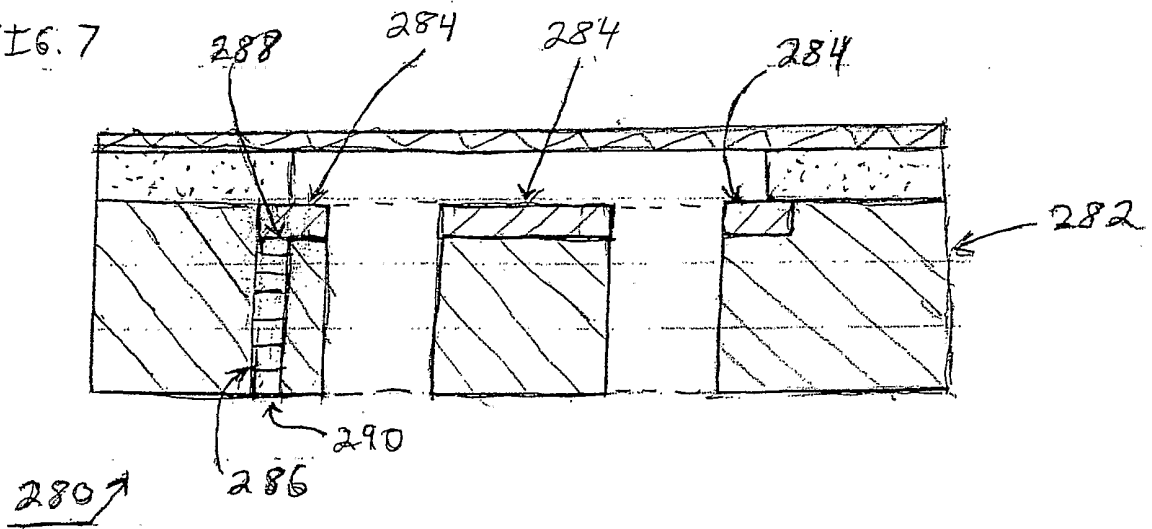

FIG. 8

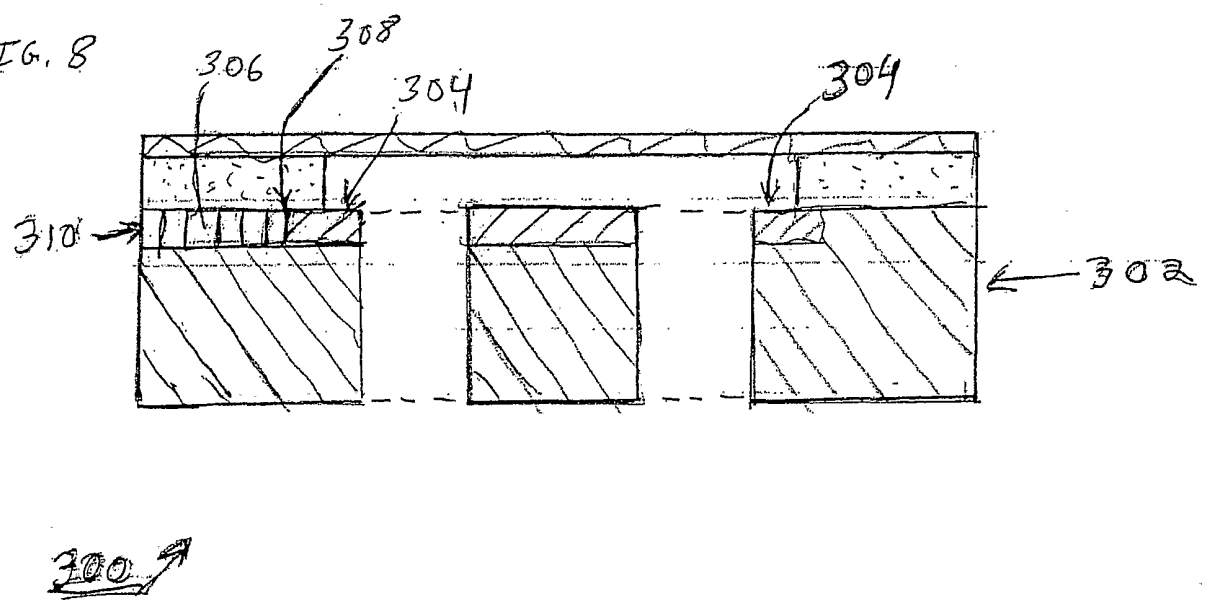

FIG. 9a

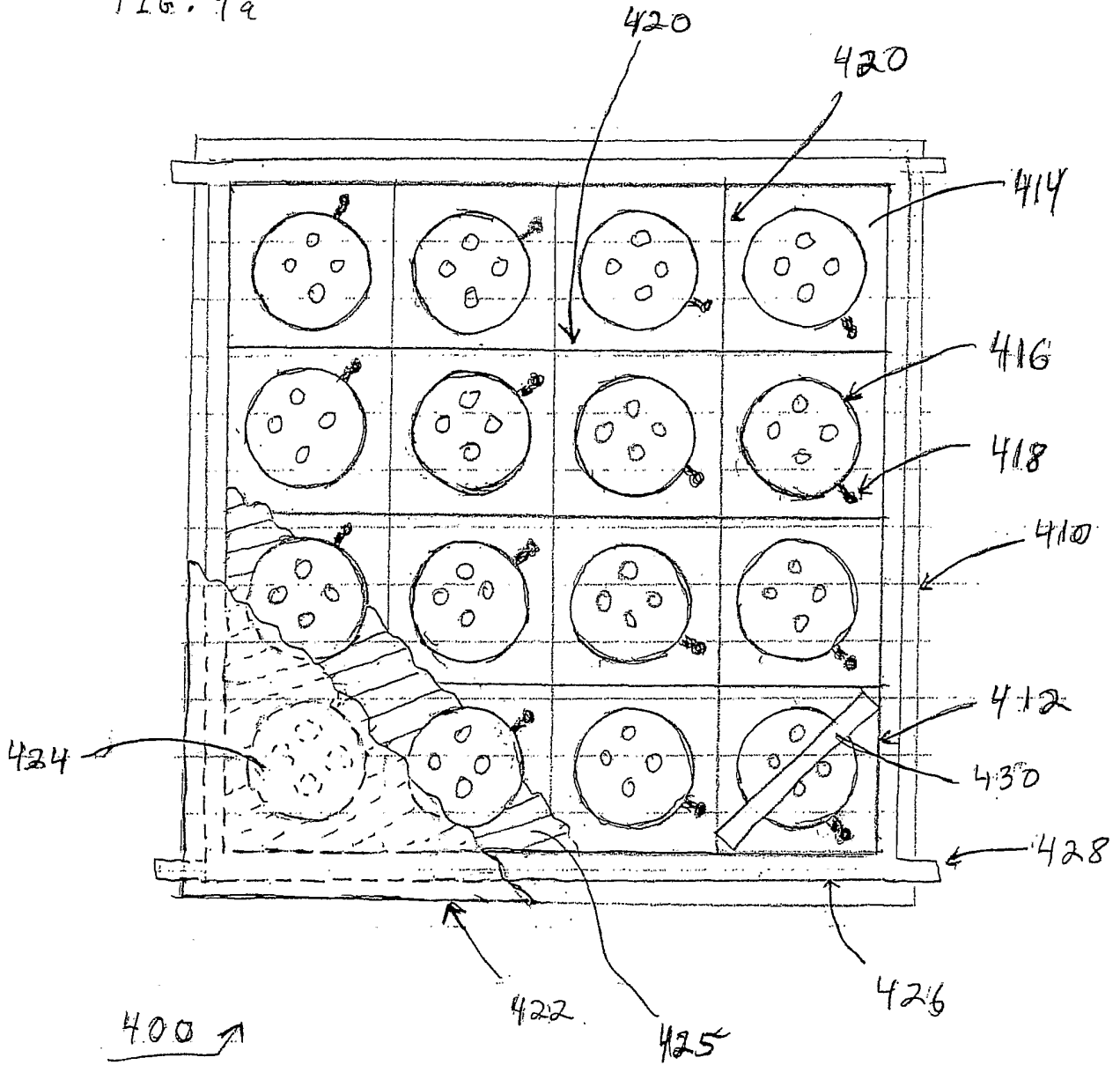
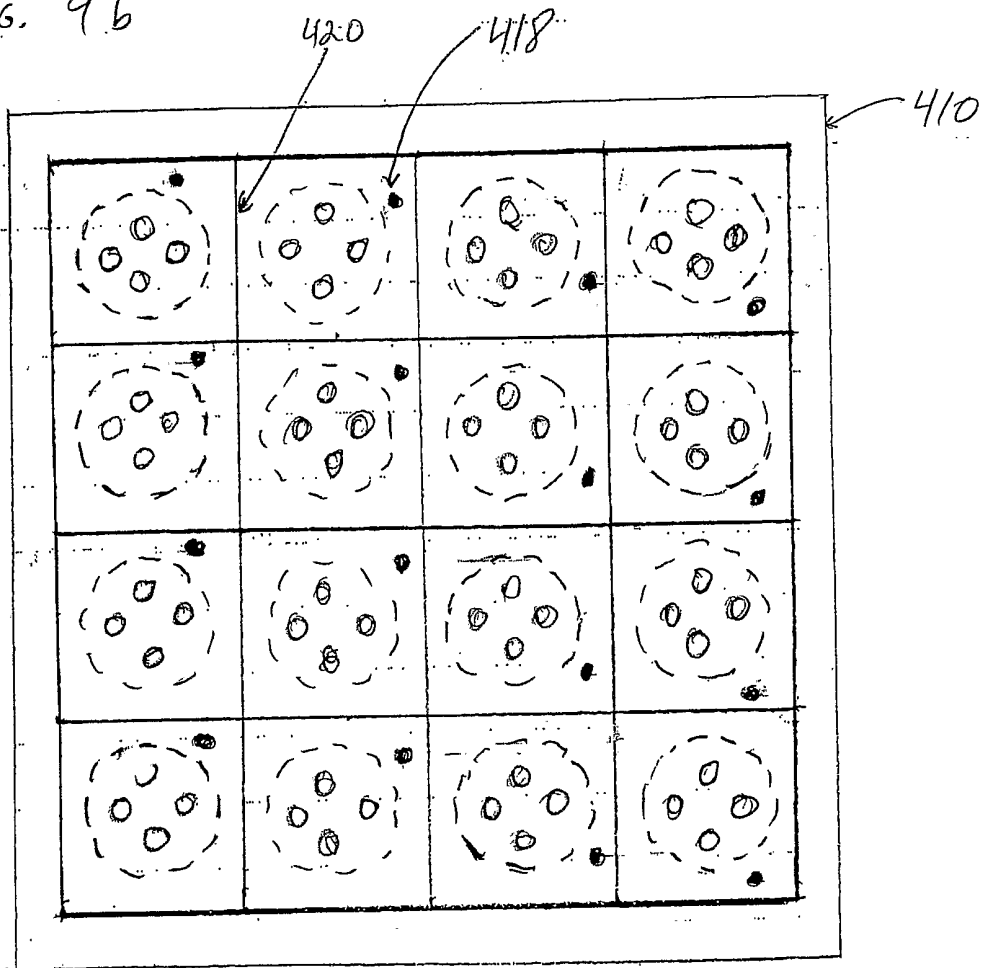

FIG. 9b



400 ↗

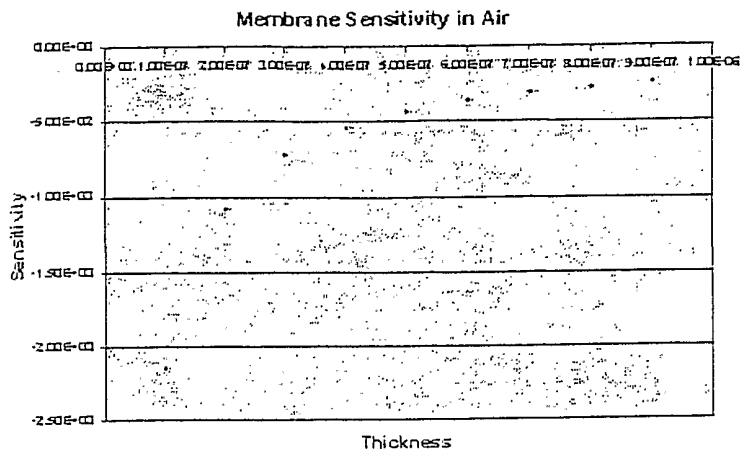

Fig. 10a

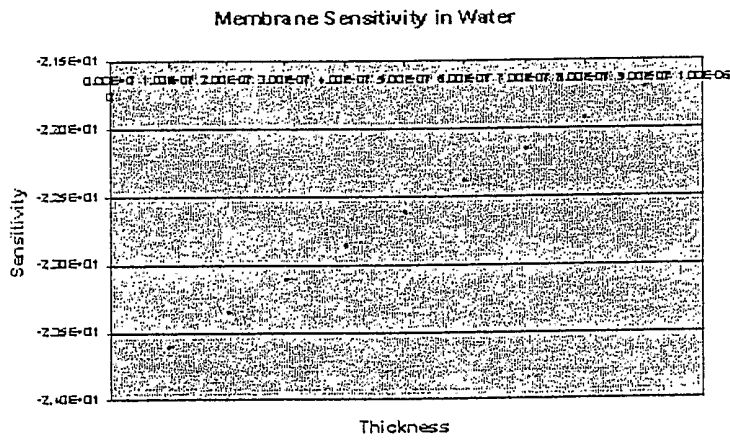

Fig. 10b

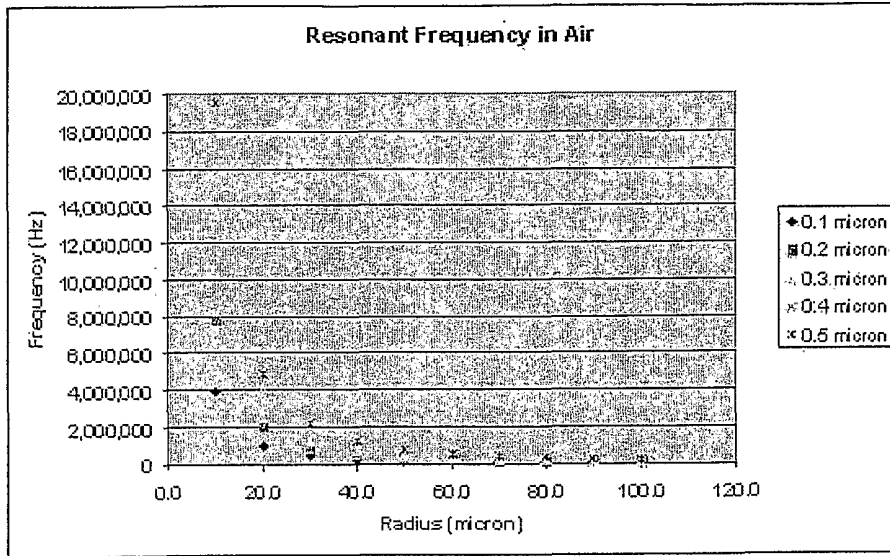

Fig. 11a

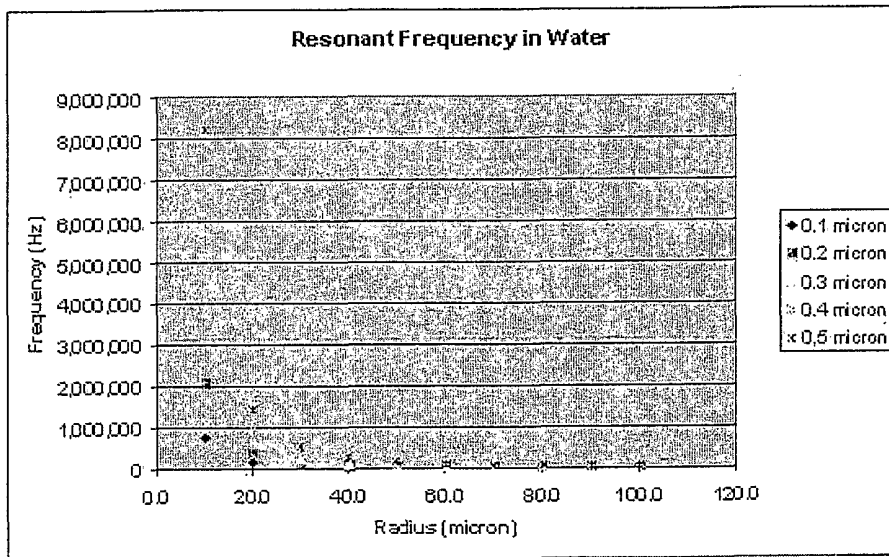
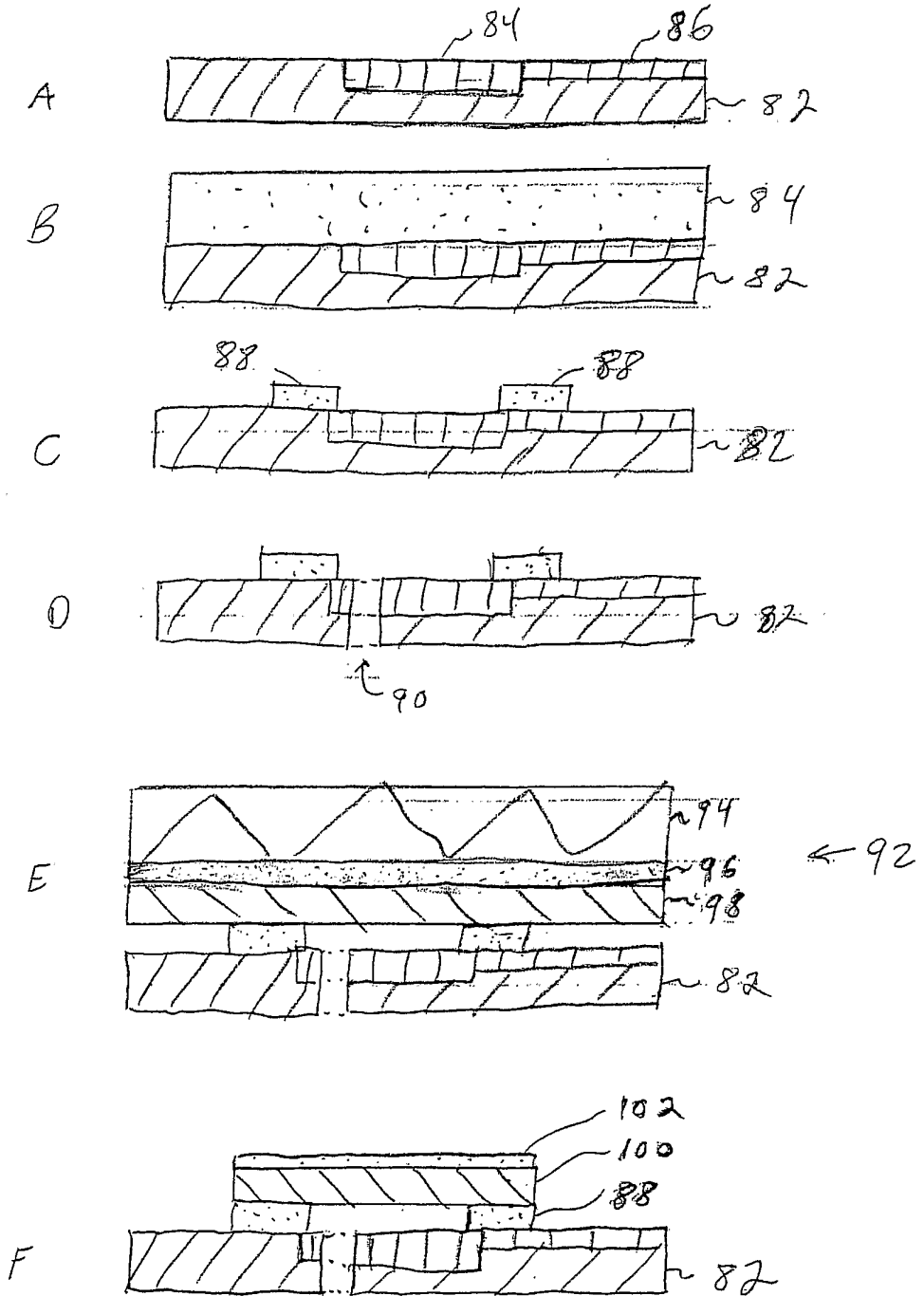

Fig. 11b

FIG. 12



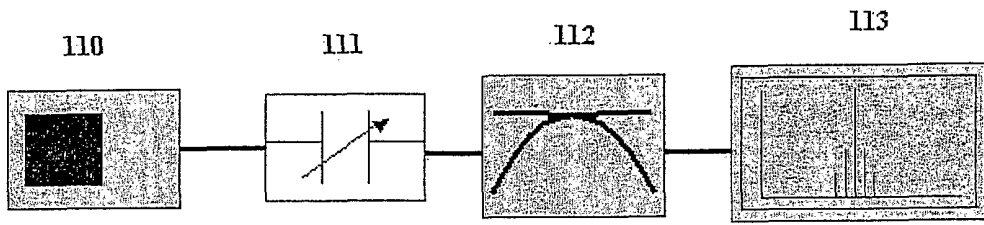

Fig. 13

100 ↗

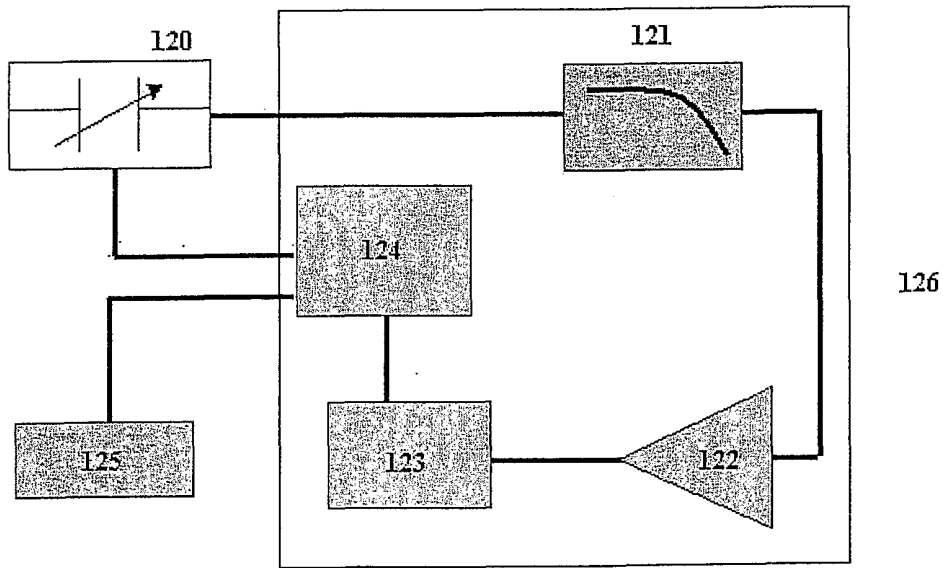

Fig. 14

115 ↗

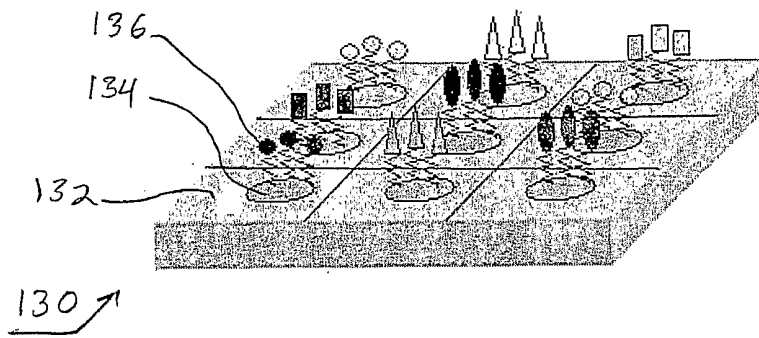

Fig. 15a

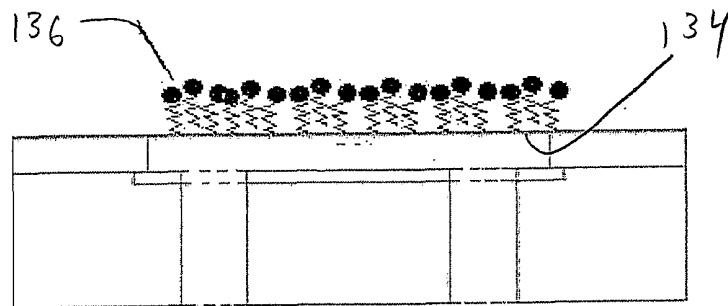

Fig. 15b