



(12) **EUROPEAN PATENT APPLICATION**

(43) Date of publication:  
**25.02.2015 Bulletin 2015/09**

(51) Int Cl.:  
**F01K 13/00** (2006.01) **F01K 15/04** (2006.01)  
**B63J 2/12** (2006.01) **B63B 35/12** (2006.01)

(21) Application number: **14166147.0**

(22) Date of filing: **28.04.2014**

(84) Designated Contracting States:  
**AL AT BE BG CH CY CZ DE DK EE ES FI FR GB GR HR HU IE IS IT LI LT LU LV MC MK MT NL NO PL PT RO RS SE SI SK SM TR**  
 Designated Extension States:  
**BA ME**

• **Kim, Soo-Jung**  
**Seongbuk-gu, Seoul (KR)**

(72) Inventors:  
 • **Kim, Soo-Jin**  
**Seongbuk-gu, Seoul (KR)**  
 • **Kim, Soo-Jung**  
**Seongbuk-gu, Seoul (KR)**

(30) Priority: **29.07.2013 KR 20130089298**

(71) Applicants:  
 • **Kim, Soo-Jin**  
**Seongbuk-gu, Seoul (KR)**

(74) Representative: **Intès, Didier Gérard André et al**  
**Cabinet Beau de Loménie**  
**158, rue de l'Université**  
**75340 Paris Cedex 07 (FR)**

(54) **Ice melting apparatus for ship voyage**

(57) Disclosed herein is an ice melting apparatus for a ship voyage, including: a boiler (150) configured to heat a thermal medium; a high temperature pump configured to transfer the heated thermal medium; a heating cover unit (110) configured to be heated by the thermal medium

transferred by the high temperature pump and attached to a bow part of a ship; and a hot gas jet unit (120) configured to be disposed in front of the heating cover unit (110) and jet the air heated by the thermal medium.

FIG. 1

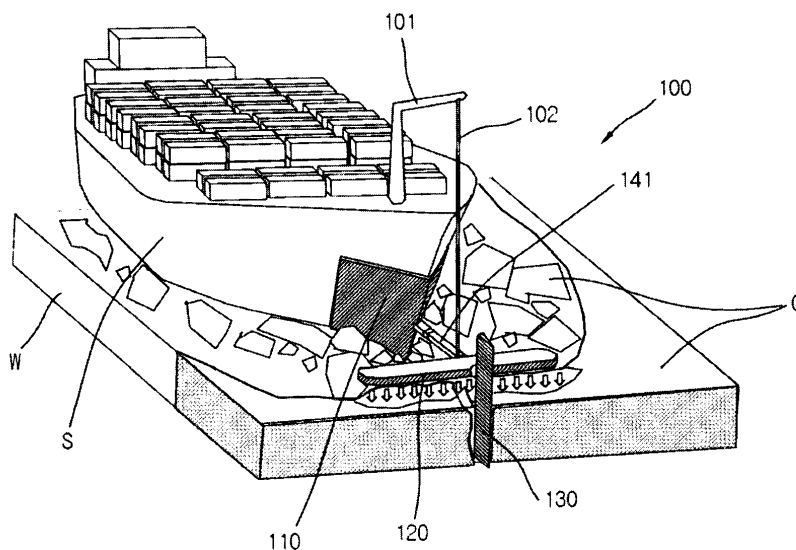

## Description

### BACKGROUND OF THE INVENTION

#### 1. Technical Field

**[0001]** The present invention relates to an ice melting apparatus for a ship voyage which is configured to be able to sail across a sea, a lake, or a river while melting ice of a sea, a lake, or a river.

#### 2. Description of the Related Art

**[0002]** As a trade between countries and a demand for a traffic volume are increased, cheap distribution costs have increasingly received attention. When a cargo ship moves from any one country in the northeast of Asia which has the relatively largest production of freight to countries which is located at an opposite side to Asia or European countries, a traditional sea route is a sea route which bypasses Africa via Hong Kong and Singapore which are located at south of the continent. On the other hand, in the case of using the Arctic Ocean, it has been known that a sailing distance is shortened by about 40% and sailing time is shortened by about 10 days, compared to the case of using the existing sea route. The reduction in the sailing distance may lead to the reduction in huge distribution costs and fuel energy consumed by an engine.

**[0003]** An ice breaker is a ship developed only to sail across a sea area covered with ice and improves a sea route by breaking ice. When the ice breaker makes a voyage, a known speed of the ice breaker is about 2.5 knot on average which is about 20 % of about 12 knot which is an average speed of a large merchant ship which sails across a general sea area without ice. Therefore, in spite of the reduced distance, the sailing time is suddenly increased and thus economic feasibility is reduced.

**[0004]** Therefore, a development of the North Pole route with economic feasibility relies on whether the ice breaker makes a voyage while easily breaking ice at low cost.

**[0005]** To overcome the disadvantages of the ice breaker, Korean Patent Laid-Open Publication No. 2012-53292 discloses that a heating member in which high-pressure steam flows is mounted at a bow part of a ship. However, the method of using steam has a problem in that a structure of various kinds of pipes and valves is complicated and costs are increased to resist a high pressure and much time is required to melt ice due to small heat capacity.

### SUMMARY OF THE INVENTION

**[0006]** The present invention has been made in an effort to provide an apparatus simply mounted in a sailing ship to remove ice at a low cost and high efficiency without using an ice breaker.

**[0007]** Further, the present invention has been made in an effort to provide an ice melting apparatus for a ship voyage which is configured to rapidly melt ice just by an instant contact with ice using thermal medium oil, instead of breaking ice.

**[0008]** According to an exemplary embodiment of the present invention, there is provided an ice melting apparatus for a ship voyage, including: a boiler configured to heat a thermal medium; a high temperature pump configured to transfer the heated thermal medium; a heating cover unit configured to be heated by the thermal medium transferred by the high temperature pump and attached to a bow part of a ship; and a hot gas jet unit configured to be disposed in front of the heating cover unit and jet the air heated by the thermal medium.

**[0009]** The high temperature pump may include a motor part and an impeller part which allows the motor part to transfer the thermal medium and the thermal medium may be configured to be circulated into the motor part.

**[0010]** The heating cover unit may have a metal pad form having a blade shape meeting left and right surfaces of the bow part and an inside of the heating cover unit may be provided with a first heat exchange to be heat-exchanged with the thermal medium.

**[0011]** The ice melting apparatus for a ship voyage may further include: a heat insulating pad configured to be disposed at a contact portion with the bow part of the heating cover unit and block heat from the heating cover unit.

**[0012]** The ice melting apparatus for a ship voyage may further include: an extending frame configured to extend from the bow part to the hot gas jet unit to support the hot gas jet unit.

**[0013]** The extending frame may be provided with a buffer part which is configured to buffer the hot gas jet unit.

**[0014]** The hot gas jet unit may be disposed in a cross direction with respect to a progress direction of the ship.

**[0015]** The hot gas jet unit may include: a compressor configured to transfer air; a second heat exchange part configured to allow the thermal medium to heat the air; and a plurality of nozzles configured to rapidly jet the heated air.

**[0016]** The ice melting apparatus for a ship voyage may further include: a heating knife unit configured to have a blade form vertically disposed in front of the heating cover unit and be heated by the thermal medium to melt ice.

**[0017]** The heating knife unit may be provided with a third heat exchange part to be heat-exchanged with the thermal medium.

**[0018]** The ice melting apparatus for a ship voyage may further include: a position control unit configured to control a posture and a depth of the heating knife unit.

**[0019]** The thermal medium may be oils which transfer heat at a temperature of 250 to 450 °C.

**[0020]** According to another exemplary embodiment of the present invention, there is provided an ice melting

apparatus for a ship voyage, including: a boiler configured to heat a thermal medium; a high temperature pump configured to transport the heated thermal medium; a heating cover unit configured to be heated by a thermal medium transported by the high temperature pump and attached to a bow part of a ship; and a heating knife unit configured to have a blade form vertically disposed in front of the heating cover unit and be heated by the thermal medium to melt ice.

**[0021]** According to still another exemplary embodiment of the present invention, there is provided an ice melting apparatus for a ship voyage, including: a boiler configured to heat a thermal medium; a high temperature pump configured to transport the heated thermal medium; a hot gas jet unit configured to be heated by the thermal medium transferred by the high temperature pump and disposed in front of a bow part of a ship to inject air heated by the thermal medium; and a heating knife unit configured to have a blade form vertically disposed in front of the hot gas jet unit and be heated by the thermal medium to melt ice.

#### BRIEF DESCRIPTION OF THE DRAWINGS

**[0022]** The above and other objects, features and advantages of the present invention will be more clearly understood from the following detailed description taken in conjunction with the accompanying drawings, in which:

FIG. 1 is a perspective view conceptually illustrating a state in which ice is being melted by a ship S equipped with an ice melting apparatus 100 for a ship voyage according to an exemplary embodiment of the present invention;

FIG. 2 is a transversal cross-sectional view conceptually illustrating a state in which ice is being melted by the ship S equipped with the ice melting apparatus 100 for a ship voyage according to the exemplary embodiment of the present invention;

FIG. 3 is a configuration diagram of the ice melting apparatus 100 for a ship voyage according to the exemplary embodiment of the present invention;

FIG. 4 is a partial plan cross-sectional view of a state in which a heating cover unit 110 according to an exemplary embodiment of the present invention is mounted;

FIG. 5 is a schematic plan cross-sectional view of a hot gas jet unit 120 according to an exemplary embodiment of the present invention; and

FIG. 6 is a cross-sectional view of a high temperature pump 160 according to an exemplary embodiment of the present invention.

#### DESCRIPTION OF THE PREFERRED EMBODIMENTS

**[0023]** Hereinafter, an ice melting apparatus 100 for a ship voyage according to an exemplary embodiment of the present invention will be described with reference to

the accompanying drawings.

**[0024]** FIG. 1 is a perspective view conceptually illustrating a state in which ice is being melted by a ship S equipped with an ice melting apparatus 100 for a ship voyage according to an exemplary embodiment of the present invention, FIG. 2 is a transversal cross-sectional view conceptually illustrating a state in which ice is being melted by the ship S equipped with the ice melting apparatus 100 for a ship voyage according to the exemplary embodiment of the present invention, FIG. 3 is a configuration diagram of the ice melting apparatus 100 for a ship voyage according to the exemplary embodiment of the present invention, FIG. 4 is a partial plan cross-sectional view of a state in which a heating cover unit 110 according to an exemplary embodiment of the present invention is mounted, and FIG. 5 is a schematic plan cross-sectional view of a hot gas jet unit 120 according to an exemplary embodiment of the present invention.

**[0025]** As illustrated in these drawings, the ice melting apparatus 100 for a ship voyage is configured to be attached to a bow part of the ship S and may be operated in a state in which the ice melting apparatus 100 for a ship voyage may be mounted in a sea area with ice and in a state in which the ice melting apparatus 100 for a ship voyage may be detached in a general sea area without ice.

**[0026]** The ice melting apparatus 100 for a ship voyage largely includes a heating cover unit 110, a hot gas jet unit 120, and a heating knife unit 130, in which these heating parts are connected to a boiler 150 and a high temperature pump 160 which are mounted in the ship S. However, the ice melting apparatus 100 for a ship voyage may be configured to include any one or a combination of two of the heating cover unit 110, the hot gas jet unit 120, and the heating knife unit 130, instead of being configured to include all of the ice melting apparatus 100 for a ship voyage.

**[0027]** The boiler 150 is configured to be able to heat a thermal medium. As the thermal medium, mineral oils which may transfer heat at a temperature of 250 to 450 °C may be used and provide a sufficient heat capacity to melt ice while keeping a liquid state even at a high temperature.

**[0028]** The thermal medium heated by the boiler 150 is supplied to the high temperature pump 160 via a first valve 171. The high temperature pump 160 is a part which circulates the high temperature thermal medium and is required to prevent the thermal medium from being leaked, keep insulation and apply a high pressure. The high temperature pump 160 will be described below in detail with reference to FIG. 6.

**[0029]** The heating cover unit 110 is configured to be heated by the thermal medium transferred by the high temperature pump 160 and is configured to be attached to the bow part of the ship S. In detail, as illustrated in FIG. 4. The heating cover unit 110 may have a metal pad form having a blade shape meeting left and right surfaces of the bow part. An inside of the heating cover unit 110

may be provided with a first heat exchange part 112 to be heat-exchanged with the thermal medium. The form of the first heat exchange part 112 may be configured in a form of a plurality of tubes or a plurality of layers in which the heat exchange is easily performed. Further, a contact portion with the bow part of the heating cover unit 110 may be provided with a heat insulating pad 115. The heat insulating pad 115 is configured to prevent the bow part from being subjected to heat degeneration or fatigue due to the high temperature heating cover unit 110 which is heated at about 250 °C by being heat-exchanged with the thermal medium of 250 to 450 °C. The heat insulating pad 115 may be made of elastic resin, rubber, or a spring material to be able to reduce an impact due to the collision with ice C which is transferred to a ship body.

**[0030]** The hot gas jet unit 120 is disposed in front of the heating cover unit 110 and is configured to be able to jet air heated by the thermal medium. The hot gas jet unit 120 may be provided with an extending frame 141, which extends from the bow part of the ship S to the hot gas jet unit 120, so as to support the hot gas jet unit 120. The extending frame 141 may be provided with a buffer part 142 to allow the hot gas jet unit 120 or the heating knife unit 130 to reduce resistance or impact force which is applied by the collision with the ice C. The buffer unit 142 may be formed of an elastic spring, an operating fluid type cylinder, and the like.

**[0031]** The hot gas jet unit 120 is disposed to a cross direction with respect to a progress direction of the ship S (see FIG. 1) and the inside thereof is provided with a second heat exchange part 122 which is formed to enable the thermal medium to heat air. The hot gas jet unit 120 may include a compressor 125 to provide compressed air (see FIG. 3) and a lower surface of the hot gas jet unit 120 may be provided with a plurality of nozzles 121 which are formed to jet the heated air toward ice at a high speed (see FIG. 5).

**[0032]** The heating knife unit 130 has a blade form vertically disposed in front of the heating cover unit 110 and is heated by the thermal medium to melt ice having a thickness of about 5 to 7 m. The inside of the heating knife unit 130 may be provided with a third heat exchange part 132 to be heat exchanged with the thermal medium. Further, a position control unit 135 to control a posture and a depth of the heating knife unit 13 depending on a thickness or a depth of ice may be disposed between the hot gas jet unit 120 and the heating knife unit 130. As the position control unit 135, a hydraulic motor, a mechanical link mechanism, and the like may be used.

**[0033]** To support or detach the ice melting apparatus 100 for a ship voyage, the ship S may be provided with a crane 101 and a cable 102.

**[0034]** Hereinafter, an operation of the ice melting apparatus 100 for a ship voyage will be described.

**[0035]** As illustrated in FIG. 1, when the ship S sails a sea area with the ice C, the heating knife unit 130 disposed at a bow part is heated at about 250 °C by the thermal medium heated at a high temperature of 250 to

450 °C. The heating knife unit 130 having the blade form provides a large amount of heat to the ice C for a short period of time when both sides of the heating knife unit 130 contact the ice C so as to be rapidly heated at 0 °C which is a temperature at which the ice C may be melted. Therefore, a widely expansive ice layer is broken.

**[0036]** The hot gas jet unit 120 rapidly jets the high temperature air heated at about 250 °C by the thermal medium to the ice C. Therefore, the ice C is formed to be easily broken into small pieces.

**[0037]** The heating cover unit 110 helps the ice melted by the heating knife unit 130 or the hot gas jet unit 120, which is disposed in front of the heating cover unit 110, to be completely separated. However, at the time of combining the heating cover unit 110, the hot gas jet unit 120, and the heating knife unit 130, any one of them may be omitted. Further, as illustrated in FIG. 3, a heating means to melt ice may be selectively used by a second valve 172 to open and close the thermal medium supplied to the heating cover unit 110 and a third valve 173 to open and close the thermal medium supplied to the hot gas jet unit 120 or the heating knife unit 130.

**[0038]** FIG. 6 is a cross-sectional view of a high temperature pump 160 according to an exemplary embodiment of the present invention. As the high temperature pump 160 according to the present embodiment, which is a high heat resistance pump capable of resisting a high temperature, a non-sealed canned motor pump in which a seal ring is not damaged even in an excessive environment, may be used. That is, the high temperature pump 160 may include a motor part and an impeller part, and a thermal medium is configured to be circulated to an inner portion of the motor part. Next, the high temperature pump 160 will be described in more detail.

**[0039]** The high temperature pump 160 may include components such as a casing 160-10, an impeller 160-15, a front housing 160-12, a rear housing 160-22, a stator unit 160-30, a rotor assembly 160-40, bearings 160-51 and 160-52, sleeves 160-55 and 160-56, an auxiliary impeller 160-60, a connector 160-70, and the like. However, in some cases, the high temperature pump 160 does not include some of the above-mentioned components or may be replaced by another form.

**[0040]** The casing 160-10, which is a component enclosing the impeller 160-15, is provided with an inlet 111 to which an operating fluid, that is, the liquid thermal medium is input and an outlet 112 transferring the operating fluid by a centrifugal force.

**[0041]** The impeller 160-15, which is a component coupled to the rotor assembly 160-40, receives a driving force provided from the rotor assembly 160-40 and forcibly guides the operating fluid in a centrifugal direction by rotation to allow the operating fluid to move toward the outlet 112 of the casing 160-10.

**[0042]** The front housing 160-21 and the rear housing 160-22 are formed in a form in which they are extended inwardly, respectively, so as to provide seats on which the bearings 160-51 and 160-52 are to be seated. In order

to couple the front housing 160-21 and the rear housing 160-22 to each other, the stator unit 160-30 is provided with the respective flanges 160-31 and 160-32. Here, the front flange 131 may be formed in a form in which it has a diameter larger than that of the rear flange 132 so as to be directly coupled to the casing 160-10. The front flange 131 and the casing 160-10 are coupled to each other by a flange bolt 135 inserted from the front flange 131 side. A high sealing force and the assembling simplification is performed by a direct coupling structure between the stator unit 160-30 and the casing 160-10. The front housing 160-21 is coupled to the front flange 131 of the stator unit 160-30 by a flange bolt 125 inserted from the front housing 160-21 side.

[0043] The rotor assembly 160-40 includes a shaft 160-41, a rotor core 160-42 fixed to the shaft 160-41, and a rotor can 143 sealing the rotor core 160-42.

[0044] The shaft 160-41 includes a through-hole 160-41a formed in a length direction at the center thereof and includes a side hole 160-41b connected to the through-hole 160-41a and formed in a radial direction. When the motor is operated, the operating fluid is introduced into the through-hole 160-41a by an action of the impeller 160-15 and is then introduced into an internal space of the motor through the side hole 160-41b.

[0045] A front end and a rear end of the rotor assembly 160-40 are fitted by the sleeves 160-53 and 160-54, respectively, and the sleeves 160-53 and 160-54 are supported by the respective bearings 160-51 and 160-52. The bearings 160-51 and 160-52 include a labyrinth 160-51a formed in spiral and axial directions, and smooth sliding between the shaft 160-41 and the bearings 160-51 and 160-52 is generated by the operating fluid moved along the labyrinth 160-51a. Therefore, a lubricating action is implemented by the thermal medium, which is the operating fluid transferred by a pump, without using a separate lubricating oil. Therefore, since a seal ring, or the like, is not used for a period in which the high temperature pump 160 is operated, leakage of the thermal medium due to breakage of the seal ring does not occur.

[0046] The stator unit 160-30 has a form in which an electric wire is wound around an iron core 160-33 and is sealed by a stator can 160-34. A front end portion and a rear end portion of the stator unit 160-30 are provided with the flanges 160-31 and 160-32 so as to be coupled to the front housing 160-21 and the rear housing 160-32, respectively, as described above.

[0047] The auxiliary impeller 160-60 provides a passage for discharging an air included in an internal space in which the rotor assembly 160-40 is mounted. That is, the auxiliary impeller 160-60 discharges the air so that the operating fluid is introduced into the internal space by rotation of the impeller 160-15 after the heat exchange type cooling apparatus for a transformer is operated and is closed when the air is completely discharged.

[0048] The connector 160-70, which is a component connecting the electric wire, or the like, of the stator unit 160-30 to an external terminal, is spaced apart from a

high temperature stator unit 160-30 by a predetermined distance by an extension tube.

[0049] As described above, since the thermal medium is introduced and circulated into the high temperature pump 160 formed in the non-sealed canned motor pump to implement a cooling action and a lubricating action of the motor part of the high temperature pump 160 without having an effect on an internal component of the motor part, the seal ring may not be damaged and durability may be increased.

[0050] According to the ice melting apparatus for a ship voyage according to the exemplary embodiment of the present invention, ice may be sequentially melted using the thermal medium having high heat capacity supplied to the high temperature pump, instead of breaking ice, thereby rapidly melting ice and since there is no need to use the thick steel plate to resist the collision with ice and crush ice, the relatively cheaper and higher-efficiency apparatus may be configured. Therefore, it is possible to save huge energy required to bypass the sea area with ice.

[0051] According to the ice melting apparatus for a ship voyage according to the exemplary embodiment of the present invention, the sealing may be kept under the vibration or the high temperature environment by applying the canned motor type having the structure in which the thermal medium is circulated in the high temperature pump, thereby stably displaying the performance even in the extreme environment.

[0052] The ice melting apparatus for a ship voyage as described above are not restrictively applied to the configuration and the method of the exemplary embodiments described above. All or some of the above-mentioned exemplary embodiments may also be selectively combined with each other so that various modifications may be made.

## Claims

1. An ice melting apparatus (100) for a ship voyage, **characterized in that** it comprises:
  - a boiler (150) configured to heat a thermal medium;
  - a high temperature pump (160) configured to transfer the heated thermal medium;
  - a heating cover unit (110) configured to be heated by a thermal medium transferred by the high temperature pump (160) and attached to a bow part of a ship (S); and
  - a hot gas jet unit (120) configured to be disposed in front of the heating cover unit (110) and jet the air heated by the thermal medium.
2. The ice melting apparatus (100) for a ship voyage according to claim 1, wherein the high temperature pump (160) includes a motor part and an impeller

- part which allows the motor part to transfer the thermal medium, and the thermal medium is configured to be circulated into the motor part.
3. The ice melting apparatus (100) for a ship voyage according to claim 1 or 2, wherein the heating cover unit (110) has a metal pad form having a blade shape meeting left and right surfaces of the bow part, and an inside of the heating cover unit (110) is provided with a first heat exchange part (112) to be heat-exchanged with the thermal medium.
4. The ice melting apparatus (100) for a ship voyage according to any one of claims 1 to claim 3, further comprising:
- a heat insulating pad (115) configured to be disposed at a contact portion with the bow part of the heating cover unit (110) and block heat from the heating cover unit (110).
5. The ice melting apparatus (100) for a ship voyage according to any one of claims 1 to 4, further comprising:
- an extending frame (141) configured to extend from the bow part to the hot gas jet unit (120) to support the hot gas jet unit (120).
6. The ice melting apparatus (100) for a ship voyage of claim 5, wherein the extending frame (141) is provided with a buffer part (142) which is configured to buffer the hot gas jet unit (120).
7. The ice melting apparatus (100) for a ship voyage according to any one of claims 1 to 6, wherein the hot gas jet unit (120) is disposed in a cross direction with respect to a progress direction of the ship (S).
8. The ice melting apparatus (100) for a ship voyage according to any one of claims 1 to 7, wherein the hot gas jet unit (120) includes:
- a compressor (125) configured to transfer air; a second heat exchange part (122) configured to allow the thermal medium to heat the air; and a plurality of nozzles (121) configured to rapidly jet the heated air.
9. The ice melting apparatus (100) for a ship voyage according to any one of claims 1 to 8, further comprising:
- a heating knife unit (130) configured to have a blade form vertically disposed in front of the heating cover unit (110) and be heated by the thermal medium to melt ice.
10. The ice melting apparatus (100) for a ship voyage according to claim 9, wherein the heating knife unit (130) is provided with a third heat exchange part (132) to be heat-exchanged with the thermal medium.
11. The ice melting apparatus (100) for a ship voyage according to claim 9 or 10, further comprising:
- a position control unit (135) configured to control a posture and a depth of the heating knife unit (130).
12. The ice melting apparatus (100) for a ship voyage according to any one of claims 1 to 11, wherein the thermal medium is oils which transfer heat at a temperature of 250 to 450 °C.
13. An ice melting apparatus (100) for a ship voyage, **characterized in that** it comprises:
- a boiler (150) configured to heat a thermal medium; a high temperature pump (160) configured to transport the heated thermal medium; a heating cover unit (110) configured to be heated by a thermal medium transported by the high temperature pump (160) and attached to a bow part of a ship (S); and a heating knife unit (130) configured to have a blade form vertically disposed in front of the heating cover unit (110) and be heated by the thermal medium to melt ice.
14. An ice melting apparatus (100) for a ship voyage, **characterized in that** it comprises:
- a boiler (150) configured to heat a thermal medium; a high temperature pump (160) configured to transport the heated thermal medium; a hot gas jet unit (120) configured to be heated by the thermal medium transferred by the high temperature pump (160) and disposed in front of a bow part of a ship (S) to inject air heated by the thermal medium; and a heating knife unit (130) configured to have a blade form vertically disposed in front of the hot gas jet unit (120) and be heated by the thermal medium to melt ice.

FIG. 1

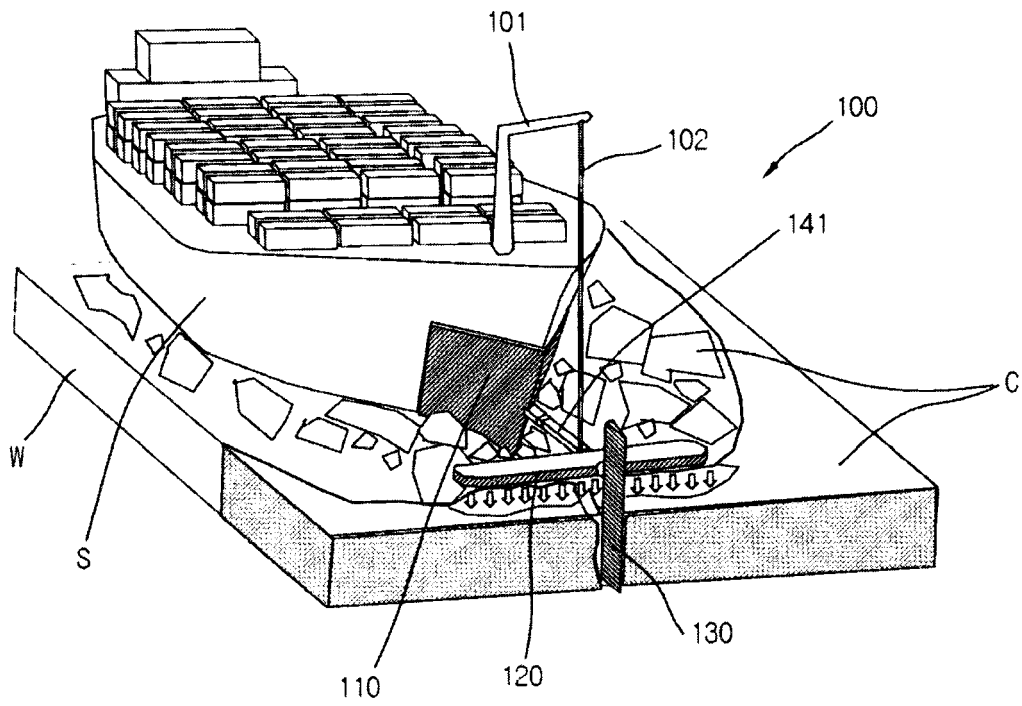

FIG. 2

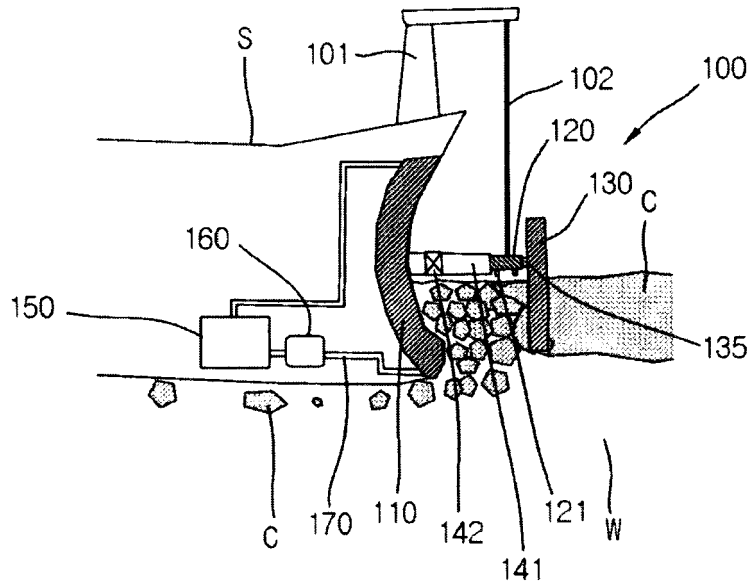

FIG. 3

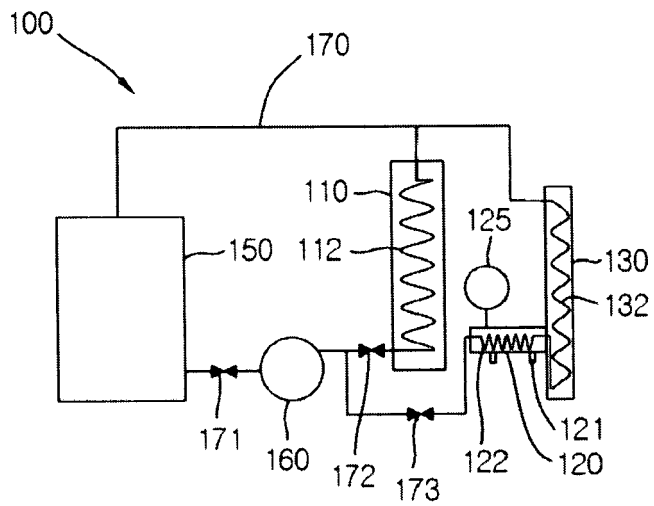

FIG. 4

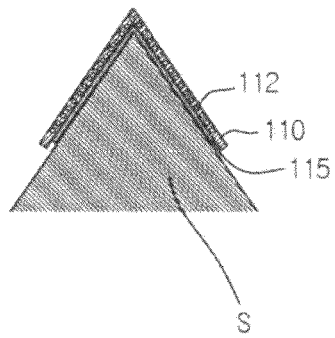

FIG. 5

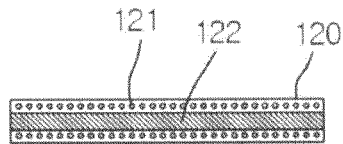
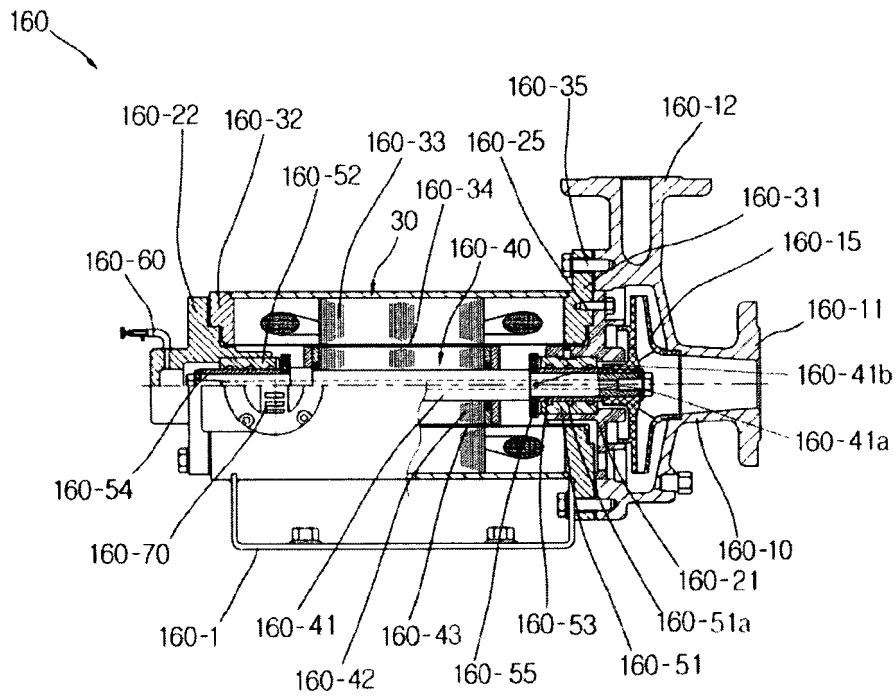

FIG. 6



**REFERENCES CITED IN THE DESCRIPTION**

*This list of references cited by the applicant is for the reader's convenience only. It does not form part of the European patent document. Even though great care has been taken in compiling the references, errors or omissions cannot be excluded and the EPO disclaims all liability in this regard.*

**Patent documents cited in the description**

- KR 201253292 [0005]