



US008976786B2

(12) **United States Patent**
Chase

(10) **Patent No.:** **US 8,976,786 B2**
(45) **Date of Patent:** ***Mar. 10, 2015**

(54) **BROADCAST INTERACTIVE TELEVISION SYSTEM**

(75) Inventor: **Christopher J. Chase**, Austin, TX (US)

(73) Assignee: **AT&T Intellectual Property I, LP**,
Atlanta, GA (US)

(*) Notice: Subject to any disclaimer, the term of this patent is extended or adjusted under 35 U.S.C. 154(b) by 127 days.

This patent is subject to a terminal disclaimer.

(21) Appl. No.: **13/613,126**

(22) Filed: **Sep. 13, 2012**

(65) **Prior Publication Data**

US 2013/0016722 A1 Jan. 17, 2013

Related U.S. Application Data

(63) Continuation of application No. 12/252,178, filed on Oct. 15, 2008, now Pat. No. 8,289,978.

(51) **Int. Cl.**

- H04L 12/28** (2006.01)
- H04L 12/18** (2006.01)
- H04L 12/701** (2013.01)
- H04L 12/761** (2013.01)
- H04L 12/723** (2013.01)

(52) **U.S. Cl.**

CPC **H04L 12/1836** (2013.01); **H04L 45/00** (2013.01); **H04L 45/16** (2013.01); **H04L 45/50** (2013.01)

USPC **370/389**; 709/249; 725/148; 370/400

(58) **Field of Classification Search**

USPC 709/252, 249, 225; 370/389, 390, 392, 370/401, 395.1, 400, 432

See application file for complete search history.

(56) **References Cited**

U.S. PATENT DOCUMENTS

6,339,595	B1 *	1/2002	Rekhter et al.	370/392
6,721,318	B1 *	4/2004	Cai et al.	370/390
6,751,218	B1 *	6/2004	Hagirahim et al.	370/390
7,095,740	B1 *	8/2006	Jagannath et al.	370/392
7,133,928	B2 *	11/2006	McCanne	709/238
7,136,374	B1 *	11/2006	Kompella	370/352
7,283,529	B2 *	10/2007	Basso et al.	370/392
7,307,990	B2 *	12/2007	Rosen et al.	370/392
7,310,730	B1 *	12/2007	Champagne et al.	713/163
7,369,556	B1 *	5/2008	Rekhter et al.	370/392
7,519,010	B1 *	4/2009	Aggarwal et al.	370/254
7,525,949	B1 *	4/2009	Rampal et al.	370/352
7,564,806	B1 *	7/2009	Aggarwal et al.	370/256
7,626,995	B2 *	12/2009	Napierala	370/432
2001/0039623	A1 *	11/2001	Ishikawa	713/201
2003/0012215	A1 *	1/2003	Novaes	370/432
2003/0076854	A1 *	4/2003	Mudhar et al.	370/432
2003/0112755	A1 *	6/2003	McDysan	370/230
2003/0142669	A1 *	7/2003	Kubota et al.	370/389
2003/0163690	A1 *	8/2003	Stewart	713/163
2003/0191841	A1 *	10/2003	DeFerranti et al.	709/226
2004/0202171	A1 *	10/2004	Hama	370/395.1

(Continued)

Primary Examiner — Pankaj Kumar

Assistant Examiner — Timothy Newlin

(74) *Attorney, Agent, or Firm* — Guntin & Gust, PLC; Ed Guntin

(57) **ABSTRACT**

A system that incorporates teachings of the present disclosure may include, for example, a system having a controller to deliver broadcast channels by way of interactive TV (iTV) edge routers using multicast virtual private networks, share a same multicast state for the broadcast channels and share a same multicast delivery tree for the broadcast channels. Other embodiments are disclosed.

20 Claims, 8 Drawing Sheets

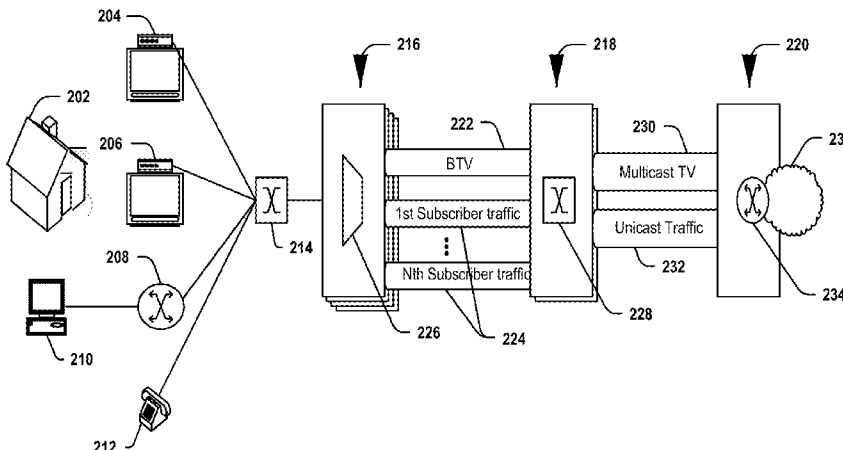

(56)

References Cited

U.S. PATENT DOCUMENTS

2005/0027782 A1* 2/2005 Jalan et al. 709/200
2005/0169270 A1* 8/2005 Mutou et al. 370/390
2006/0147204 A1* 7/2006 Yasukawa et al. 398/26
2006/0165087 A1* 7/2006 Page et al. 370/395.3
2006/0187950 A1* 8/2006 Bou-Diab et al. 370/432

2006/0268871 A1* 11/2006 Van Zijst 370/390
2007/0025276 A1* 2/2007 Zwiebel et al. 370/256
2007/0083907 A1 4/2007 Serbest
2007/0097860 A1 5/2007 Rys
2007/0115990 A1* 5/2007 Asati et al. 370/392
2007/0147372 A1* 6/2007 Liu et al. 370/390
2008/0168523 A1 7/2008 Ansari

* cited by examiner

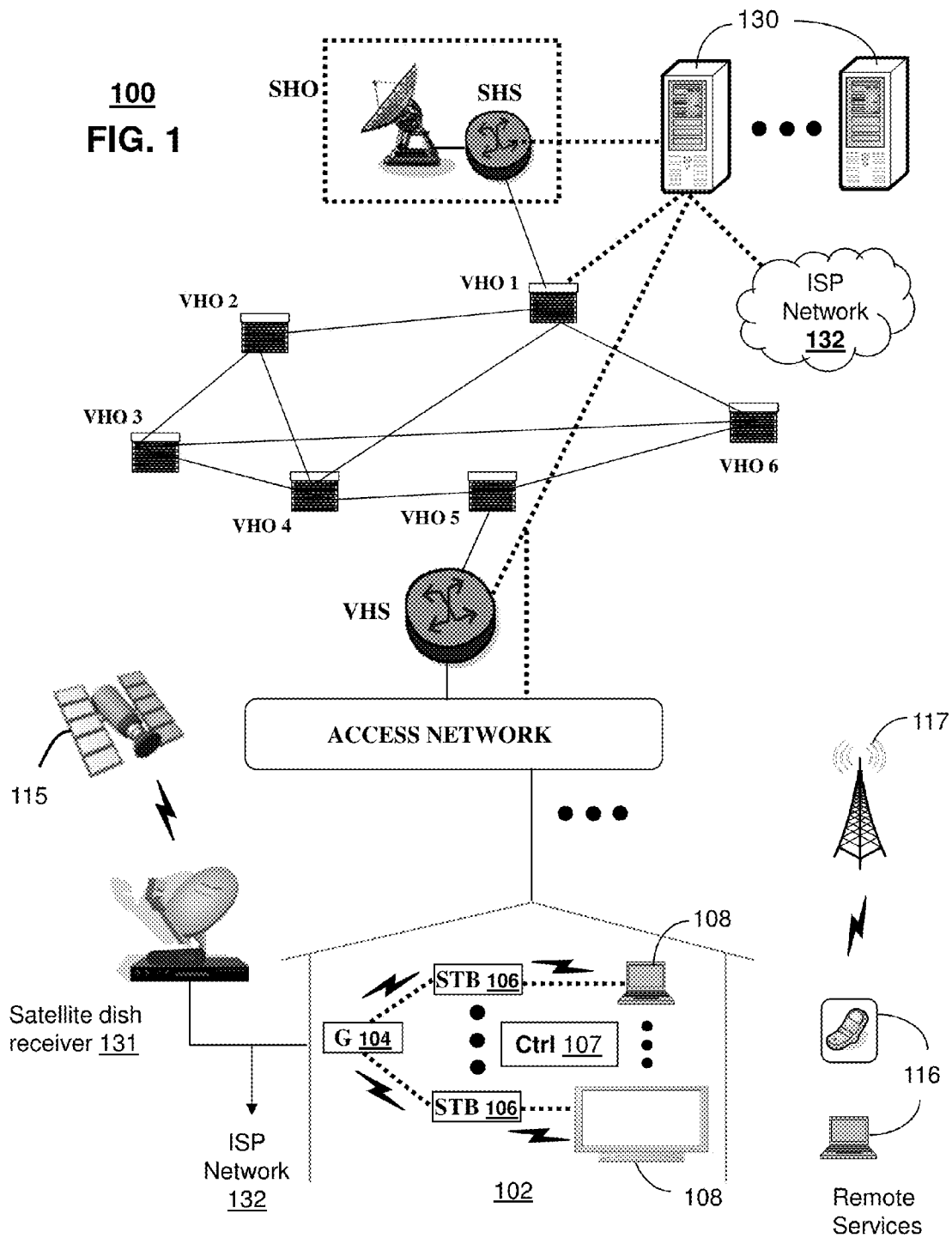

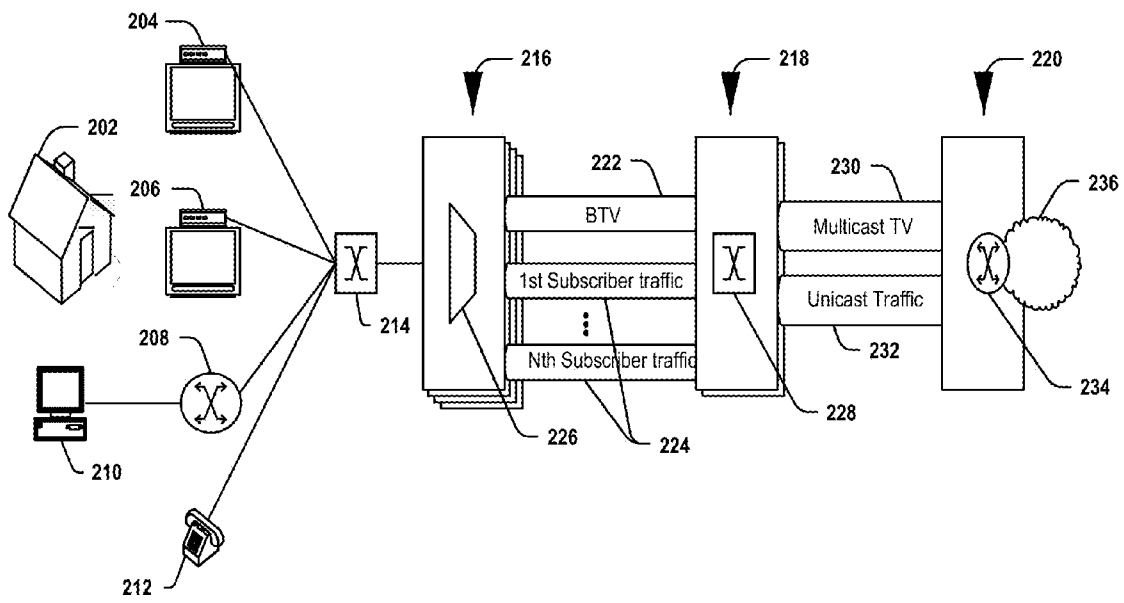

200
FIG. 2

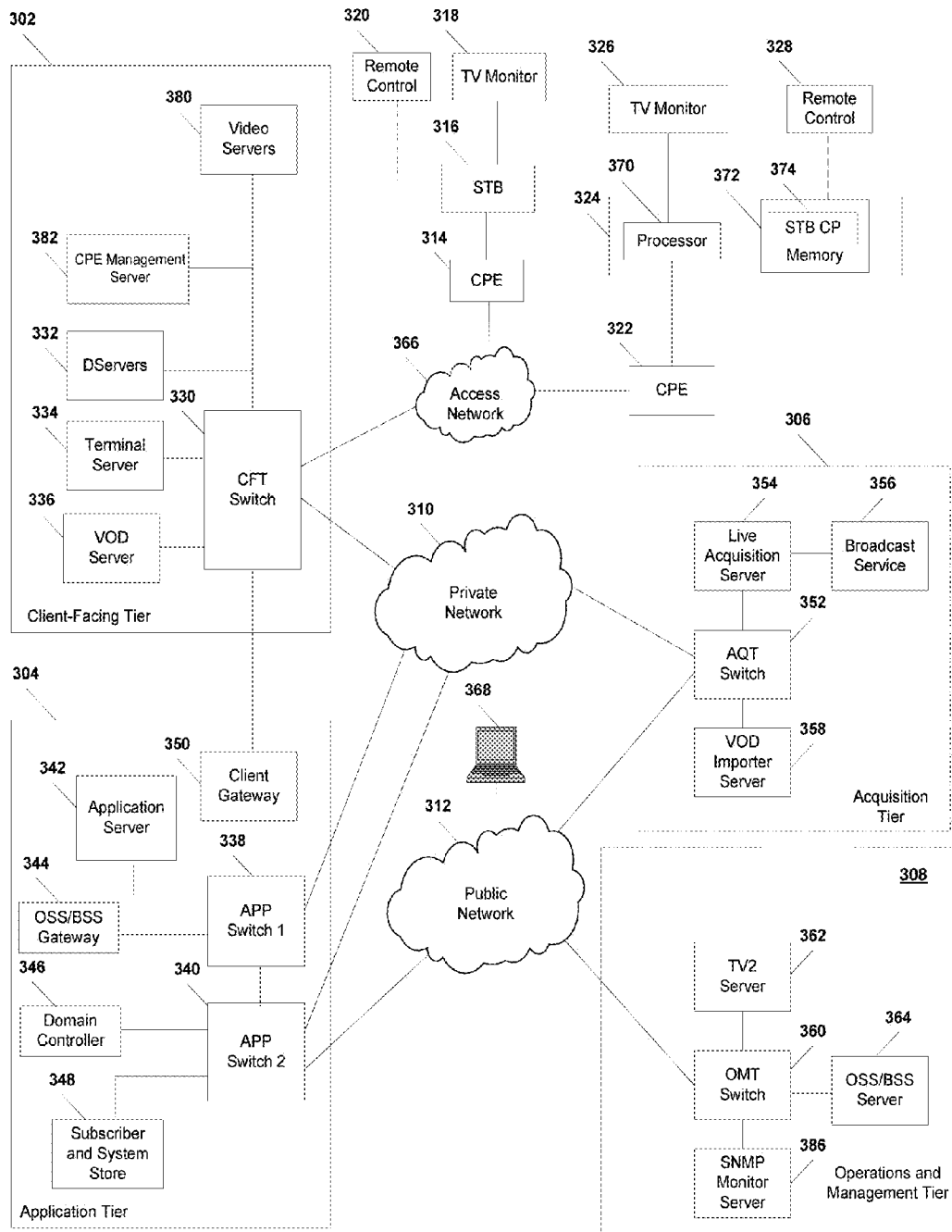

300
FIG. 3

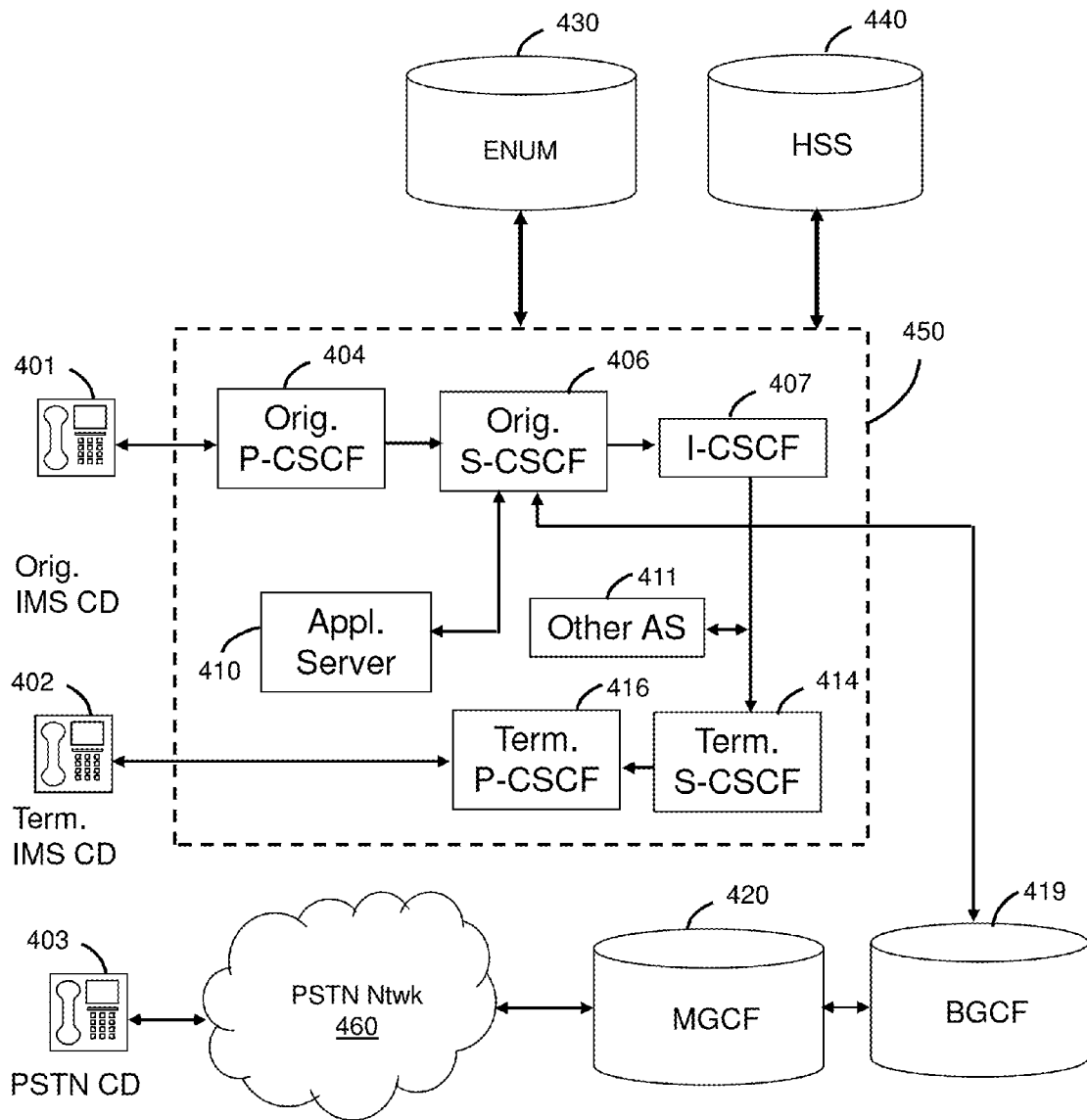

400
FIG. 4

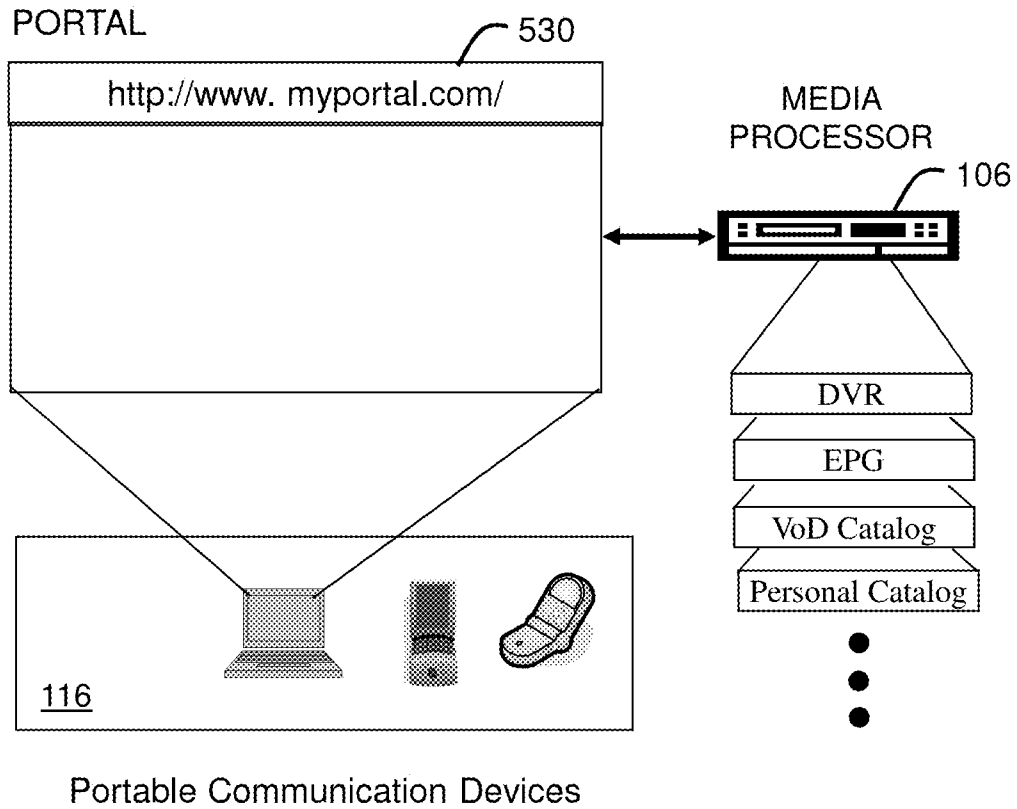

500
FIG. 5

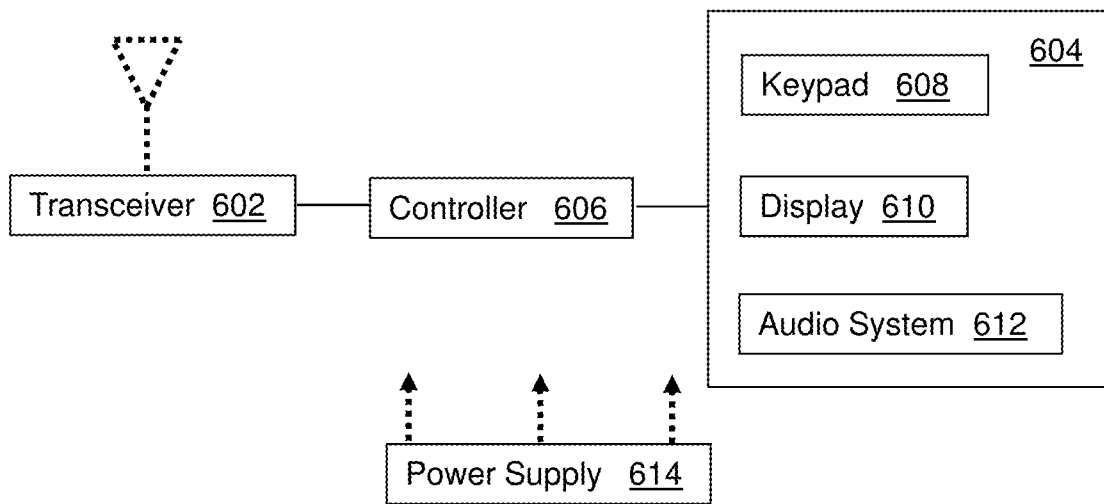

600
FIG. 6

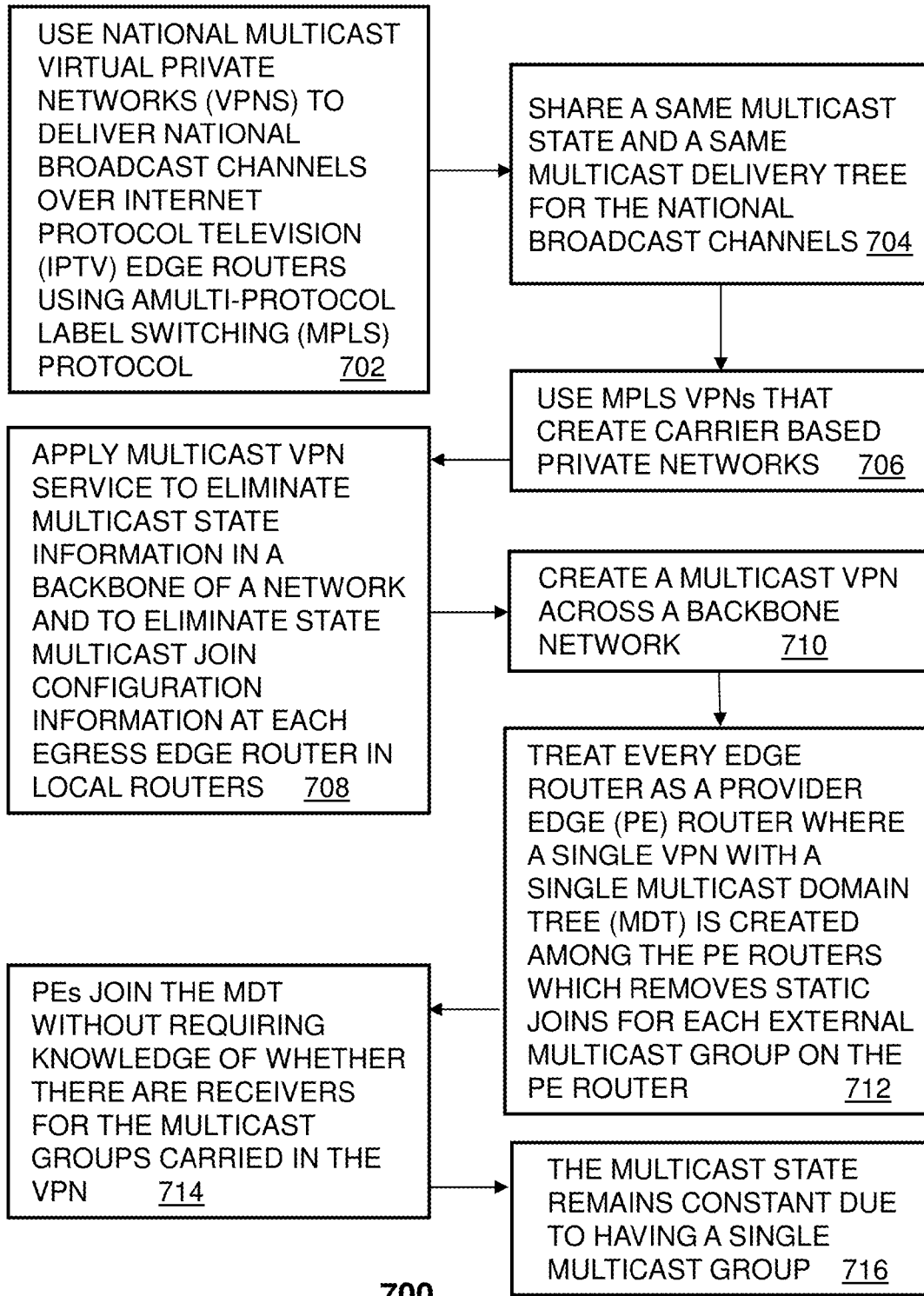

FIG. 7

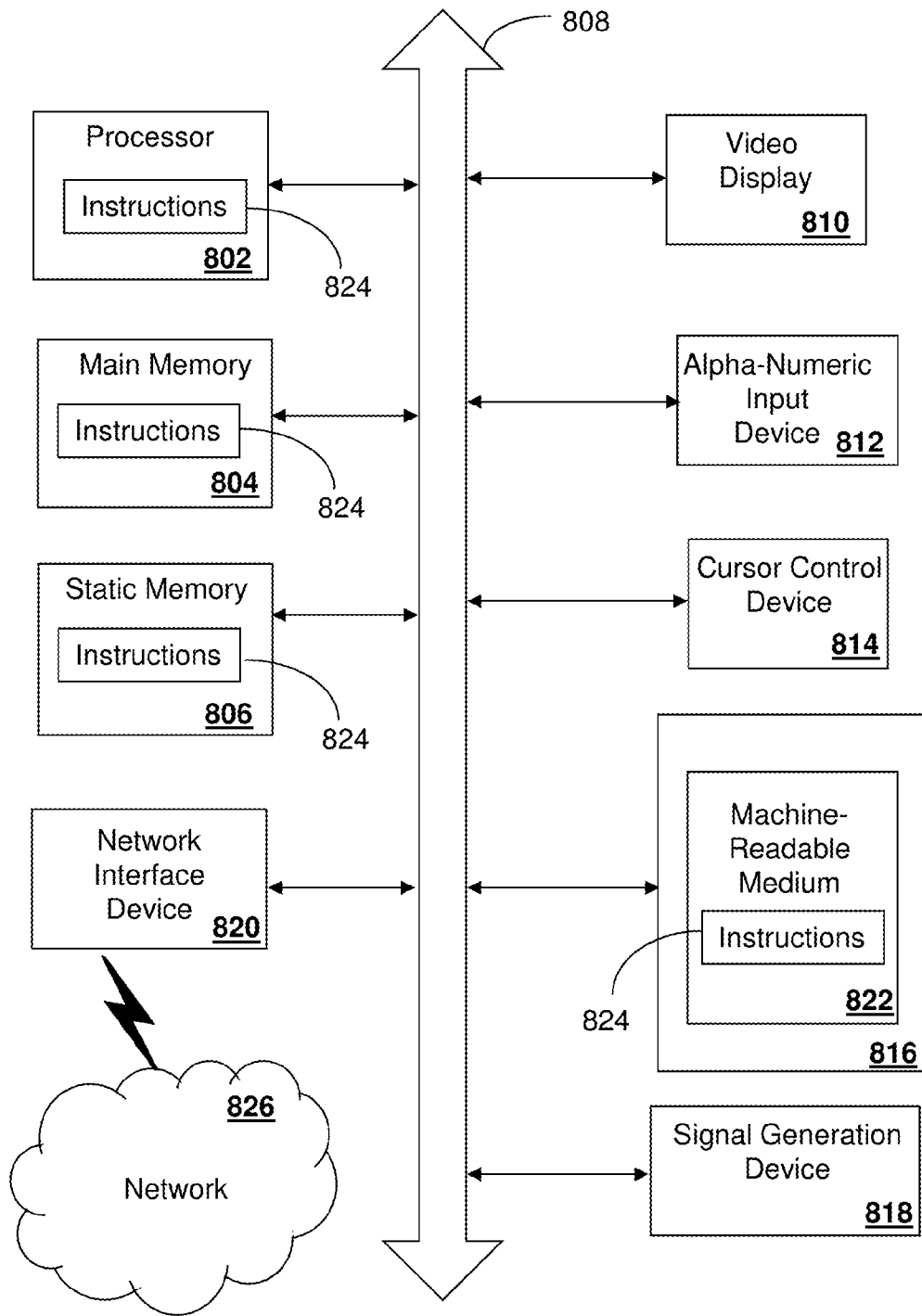

FIG. 8 800

BROADCAST INTERACTIVE TELEVISION SYSTEM

CROSS-REFERENCE TO RELATED APPLICATIONS

This application is a continuation of and claims priority to U.S. patent application Ser. No. 12/252,178 filed Oct. 15, 2008, which is incorporated herein by reference in its entirety.

FIELD OF THE DISCLOSURE

The present disclosure relates generally to interactive television (iTV) and more specifically to a broadcast iTV system.

BACKGROUND

To efficiently deliver broadcast iTV in a network of users, Internet Protocol (IP) multicast can be used. Multicast provides substantially better bandwidth efficiencies over unicast delivery. For national channels the iTV streams can be sent to local markets, independent of whether there are currently viewers in each local market for a particular channel. This is done to improve channel change time latency. To accomplish this, static joins can be created on every edge delivery router in the network across all local markets. Hundreds of channels have been made available by iTV service providers and additional channels numbering in the thousands are expected in the near future. The increase in channels is not just due to new content, but also due to variations for given content that can include channels for both standard definition resolution as well as high definition resolution. "Picture in Picture" resolution can be yet another "channel" stream. Multiple camera angles for sporting events can also add channel streams.

As more channels are added to the iTV network, the state information grows. When nodes are added to the iTV network or maintenance is performed on new nodes or links or when there are node or link failures, the time to reroute the multicast traffic depends on an amount of multicast routing states present in the network. Furthermore, pre-positioning multicast states in every local market edge router can require configuring static multicast joins in every one of the local market edge routers.

BRIEF DESCRIPTION OF THE DRAWINGS

FIGS. 1-4 depict illustrative embodiments of communication systems that provide media services;

FIG. 5 depicts an illustrative embodiment of a portal interacting with at least one among the communication systems of FIGS. 1-4;

FIG. 6 depicts an illustrative embodiment of a communication device utilized in the communication systems of FIGS. 1-4;

FIG. 7 depicts an illustrative embodiment of a method operating in portions of the communication systems of FIGS. 1-4; and

FIG. 8 is a diagrammatic representation of a machine in the form of a computer system within which a set of instructions, when executed, may cause the machine to perform any one or more of the methodologies discussed herein.

DETAILED DESCRIPTION

One embodiment of the present disclosure entails using national multicast VPNs to deliver national broadcast channels by way of IPTV edge routers using a multi-protocol label

switching (MPLS) protocol and sharing a same multicast state and a same multicast delivery tree for the national broadcast channels.

Another embodiment of the present disclosure entails a computer-readable storage medium that includes computer instructions for delivering broadcast channels by way of IPTV edge routers using multicast VPNs and applying an MPLS protocol to the multicast VPNs to share a same multicast state for the broadcast channels.

Yet another embodiment of the present disclosure entails a system having a controller to deliver broadcast channels by way of interactive TV (iTV) edge routers using multicast VPNs, share a same multicast state for the broadcast channels and share a same multicast delivery tree for the broadcast channels.

Yet another embodiment of the present disclosure entails a network architecture having a plurality of multicast VPNs used to deliver broadcast channels by way of iTV edge routers and a controller adapted to cause the iTV edge routers to share a same multicast state for the broadcast channels and to share a same multicast delivery tree for the broadcast channels.

FIG. 1 depicts an illustrative embodiment of a first communication system **100** for delivering media content. The communication system **100** can represent an Internet Protocol Television (IPTV) broadcast media system. In a typical IPTV infrastructure, there is a super head-end office (SHO) with at least one super headend office server (SHS) which receives national media programs from satellite and/or media servers from service providers of multimedia broadcast channels. In the present context, media programs can represent audio content, moving image content such as videos, still image content, and/or combinations thereof. The SHS server forwards IP packets associated with the media content to video head-end servers (VHS) via a network of aggregation points such as video head-end offices (VHO) according to a common multicast communication method.

The VHS then distributes multimedia broadcast programs via an access network to commercial and/or residential buildings **102** housing a gateway **104** (such as a residential gateway or RG). The access network can represent a bank of digital subscriber line access multiplexers (DSLAMs) located in a central office or a service area interface that provide broadband services over optical links or copper twisted pairs to buildings **102**. The gateway **104** distributes broadcast signals to media processors **106** such as Set-Top Boxes (STBs) which in turn present broadcast selections to media devices **108** such as computers or television sets managed in some instances by a media controller **107** (such as an infrared or RF remote control). Unicast traffic can also be exchanged between the media processors **106** and subsystems of the IPTV media system for services such as video-on-demand (VoD). It will be appreciated by one of ordinary skill in the art that the media devices **108** and/or portable communication devices **116** shown in FIG. 1 can be an integral part of the media processor **106** and can be communicatively coupled to the gateway **104**. In this particular embodiment, an integral device such as described can receive, respond, process and present multicast or unicast media content.

The IPTV media system can be coupled to one or more computing devices **130** a portion of which can operate as a web server for providing portal services over an Internet Service Provider (ISP) network **132** to fixed line media devices **108** or portable communication devices **116** by way of a wireless access point **117** providing Wireless Fidelity or WiFi services, or cellular communication services (such as GSM, CDMA, UMTS, WiMAX, etc.).

A satellite broadcast television system can be used in place of the IPTV media system. In this embodiment, signals transmitted by a satellite 115 can be intercepted by a satellite dish receiver 131 coupled to building 102 which conveys media signals to the media processors 106. The media receivers 106 can be equipped with a broadband port to the ISP network 132. Although not shown, the communication system 100 can also be combined or replaced with analog or digital broadcast distributions systems such as cable TV systems.

FIG. 2 depicts an illustrative embodiment of a second communication system 200 for delivering media content. Communication system 200 can be overlaid or operably coupled with communication system 100 as another representative embodiment of said communication system. The system 200 includes a distribution switch/router system 228 at a central office 218. The distribution switch/router system 228 receives video data via a multicast television stream 230 from a second distribution switch/router 234 at an intermediate office 220. The multicast television stream 230 includes Internet Protocol (IP) data packets addressed to a multicast IP address associated with a television channel. The distribution switch/router system 228 can cache data associated with each television channel received from the intermediate office 220.

The distribution switch/router system 228 also receives unicast data traffic from the intermediate office 220 via a unicast traffic stream 232. The unicast traffic stream 232 includes data packets related to devices located at a particular residence, such as the residence 202. For example, the unicast traffic stream 232 can include data traffic related to a digital subscriber line, a telephone line, another data connection, or any combination thereof. To illustrate, the unicast traffic stream 232 can communicate data packets to and from a telephone 212 associated with a subscriber at the residence 202. The telephone 212 can be a Voice over Internet Protocol (VoIP) telephone. To further illustrate, the unicast traffic stream 232 can communicate data packets to and from a personal computer 210 at the residence 202 via one or more data routers 208. In an additional illustration, the unicast traffic stream 232 can communicate data packets to and from a set-top box device, such as the set-top box devices 204, 206. The unicast traffic stream 232 can communicate data packets to and from the devices located at the residence 202 via one or more residential gateways 214 associated with the residence 202.

The distribution switch/router system 228 can send data to one or more access switch/router systems 226. The access switch/router system 226 can include or be included within a service area interface 216. In a particular embodiment, the access switch/router system 226 can include a DSLAM. The access switch/router system 226 can receive data from the distribution switch/router system 228 via a broadcast television (BTV) stream 222 and a plurality of unicast subscriber traffic streams 224. The BTV stream 222 can be used to communicate video data packets associated with a multicast stream.

For example, the BTV stream 222 can include a multicast virtual local area network (VLAN) connection between the distribution switch/router system 228 and the access switch/router system 226. Each of the plurality of subscriber traffic streams 224 can be used to communicate subscriber specific data packets. For example, the first subscriber traffic stream can communicate data related to a first subscriber, and the nth subscriber traffic stream can communicate data related to an nth subscriber. Each subscriber to the system 200 can be associated with a respective subscriber traffic stream 224. The subscriber traffic stream 224 can include a subscriber VLAN connection between the distribution switch/router system 228

and the access switch/router system 226 that is associated with a particular set-top box device 204, 206, a particular residence 202, a particular residential gateway 214, another device associated with a subscriber, or any combination thereof.

In an illustrative embodiment, a set-top box device, such as the set-top box device 204, receives a channel change command from an input device, such as a remote control device. The channel change command can indicate selection of an IPTV channel. After receiving the channel change command, the set-top box device 204 generates channel selection data that indicates the selection of the IPTV channel. The set-top box device 204 can send the channel selection data to the access switch/router system 226 via the residential gateway 214. The channel selection data can include an Internet Group Management Protocol (IGMP) Join request. In an illustrative embodiment, the access switch/router system 226 can identify whether it is joined to a multicast group associated with the requested channel based on information in the IGMP Join request.

If the access switch/router system 226 is not joined to the multicast group associated with the requested channel, the access switch/router system 226 can generate a multicast stream request. The multicast stream request can be generated by modifying the received channel selection data. In an illustrative embodiment, the access switch/router system 226 can modify an IGMP Join request to produce a proxy IGMP Join request. The access switch/router system 226 can send the multicast stream request to the distribution switch/router system 228 via the BTV stream 222. In response to receiving the multicast stream request, the distribution switch/router system 228 can send a stream associated with the requested channel to the access switch/router system 226 via the BTV stream 222.

FIG. 3 depicts an illustrative embodiment of a third communication system 300 for delivering media content. Communication system 300 can be overlaid or operably coupled with communication systems 100-200 as another representative embodiment of said communication systems. As shown, the system 300 can include a client facing tier 302, an application tier 304, an acquisition tier 306, and an operations and management tier 308. Each tier 302, 304, 306, 308 is coupled to a private network 310, such as a network of common packet-switched routers and/or switches; to a public network 312, such as the Internet; or to both the private network 310 and the public network 312. For example, the client-facing tier 302 can be coupled to the private network 310. Further, the application tier 304 can be coupled to the private network 310 and to the public network 312. The acquisition tier 306 can also be coupled to the private network 310 and to the public network 312. Additionally, the operations and management tier 308 can be coupled to the public network 312.

As illustrated in FIG. 3, the various tiers 302, 304, 306, 308 communicate with each other via the private network 310 and the public network 312. For instance, the client-facing tier 302 can communicate with the application tier 304 and the acquisition tier 306 via the private network 310. The application tier 304 can communicate with the acquisition tier 306 via the private network 310. Further, the application tier 304 can communicate with the acquisition tier 306 and the operations and management tier 308 via the public network 312. Moreover, the acquisition tier 306 can communicate with the operations and management tier 308 via the public network 312. In a particular embodiment, elements of the application tier 304, including, but not limited to, a client gateway 350, can communicate directly with the client-facing tier 302.

The client-facing tier **302** can communicate with user equipment via an access network **366**, such as an IPTV access network. In an illustrative embodiment, customer premises equipment (CPE) **314**, **322** can be coupled to a local switch, router, or other device of the access network **366**. The client-facing tier **302** can communicate with a first representative set-top box device **316** via the first CPE **314** and with a second representative set-top box device **324** via the second CPE **322**. In a particular embodiment, the first representative set-top box device **316** and the first CPE **314** can be located at a first customer premise, and the second representative set-top box device **324** and the second CPE **322** can be located at a second customer premise.

In another particular embodiment, the first representative set-top box device **316** and the second representative set-top box device **324** can be located at a single customer premise, both coupled to one of the CPE **314**, **322**. The CPE **314**, **322** can include routers, local area network devices, modems, such as digital subscriber line (DSL) modems, any other suitable devices for facilitating communication between a set-top box device and the access network **366**, or any combination thereof.

In an illustrative embodiment, the client-facing tier **302** can be coupled to the CPE **314**, **322** via fiber optic cables. In another illustrative embodiment, the CPE **314**, **322** can include DSL modems that are coupled to one or more network nodes via twisted pairs, and the client-facing tier **302** can be coupled to the network nodes via fiber-optic cables. Each set-top box device **316**, **324** can process data received via the access network **366**, via a common IPTV software platform.

The first set-top box device **316** can be coupled to a first external display device, such as a first television monitor **318**, and the second set-top box device **324** can be coupled to a second external display device, such as a second television monitor **326**. Moreover, the first set-top box device **316** can communicate with a first remote control **320**, and the second set-top box device **324** can communicate with a second remote control **328**. The set-top box devices **316**, **324** can include IPTV set-top box devices; video gaming devices or consoles that are adapted to receive IPTV content; personal computers or other computing devices that are adapted to emulate set-top box device functionalities; any other device adapted to receive IPTV content and transmit data to an IPTV system via an access network; or any combination thereof.

In an illustrative, non-limiting embodiment, each set-top box device **316**, **324** can receive data, video, or any combination thereof, from the client-facing tier **302** via the access network **366** and render or display the data, video, or any combination thereof, at the display device **318**, **326** to which it is coupled. In an illustrative embodiment, the set-top box devices **316**, **324** can include tuners that receive and decode television programming signals or packet streams for transmission to the display devices **318**, **326**. Further, the set-top box devices **316**, **324** can each include a STB processor **370** and a STB memory device **372** that is accessible to the STB processor **370**. In one embodiment, a computer program, such as the STB computer program **374**, can be embedded within the STB memory device **372**.

In an illustrative embodiment, the client-facing tier **302** can include a client-facing tier (CFT) switch **330** that manages communication between the client-facing tier **302** and the access network **366** and between the client-facing tier **302** and the private network **310**. As illustrated, the CFT switch **330** is coupled to one or more distribution servers, such as Distribution-servers (D-servers) **332**, that store, format, encode, replicate, or otherwise manipulate or prepare video content for communication from the client-facing tier **302** to the set-top

box devices **316**, **324**. The CFT switch **330** can also be coupled to a terminal server **334** that provides terminal devices with a point of connection to the IPTV system **300** via the client-facing tier **302**.

In a particular embodiment, the CFT switch **330** can be coupled to a VoD server **336** that stores or provides VoD content imported by the IPTV system **300**. Further, the CFT switch **330** is coupled to one or more video servers **380** that receive video content and transmit the content to the set-top boxes **316**, **324** via the access network **366**. The client-facing tier **302** may include a CPE management server **382** that manages communications to and from the CPE **314** and the CPE **322**. For example, the CPE management server **382** may collect performance data associated with the set-top box devices **316**, **324** from the CPE **314** or the CPE **322** and forward the collected performance data to a server associated with the operations and management tier **308**.

In an illustrative embodiment, the client-facing tier **302** can communicate with a large number of set-top boxes, such as the representative set-top boxes **316**, **324**, over a wide geographic area, such as a metropolitan area, a viewing area, a statewide area, a regional area, a nationwide area or any other suitable geographic area, market area, or subscriber or customer group that can be supported by networking the client-facing tier **302** to numerous set-top box devices. In a particular embodiment, the CFT switch **330**, or any portion thereof, can include a multicast router or switch that communicates with multiple set-top box devices via a multicast-enabled network.

As illustrated in FIG. 3, the application tier **304** can communicate with both the private network **310** and the public network **312**. The application tier **304** can include a first application tier (APP) switch **338** and a second APP switch **340**. In a particular embodiment, the first APP switch **338** can be coupled to the second APP switch **340**. The first APP switch **338** can be coupled to an application server **342** and to an OSS/BSS gateway **344**. In a particular embodiment, the application server **342** can provide applications to the set-top box devices **316**, **324** via the access network **366**, which enable the set-top box devices **316**, **324** to provide functions, such as interactive program guides, video gaming, display, messaging, processing of VoD material and other IPTV content, etc. In an illustrative embodiment, the application server **342** can provide location information to the set-top box devices **316**, **324**. In a particular embodiment, the OSS/BSS gateway **344** includes operation systems and support (OSS) data, as well as billing systems and support (BSS) data. In one embodiment, the OSS/BSS gateway **344** can provide or restrict access to an OSS/BSS server **364** that stores operations and billing systems data.

The second APP switch **340** can be coupled to a domain controller **346** that provides Internet access, for example, to users at their computers **368** via the public network **312**. For example, the domain controller **346** can provide remote Internet access to IPTV account information, e-mail, personalized Internet services, or other online services via the public network **312**. In addition, the second APP switch **340** can be coupled to a subscriber and system store **348** that includes account information, such as account information that is associated with users who access the IPTV system **300** via the private network **310** or the public network **312**. In an illustrative embodiment, the subscriber and system store **348** can store subscriber or customer data and create subscriber or customer profiles that are associated with IP addresses, stock-keeping unit (SKU) numbers, other identifiers, or any combination thereof, of corresponding set-top box devices **316**, **324**. In another illustrative embodiment, the subscriber and

system store can store data associated with capabilities of set-top box devices associated with particular customers.

In a particular embodiment, the application tier **304** can include a client gateway **350** that communicates data directly to the client-facing tier **302**. In this embodiment, the client gateway **350** can be coupled directly to the CFT switch **330**. The client gateway **350** can provide user access to the private network **310** and the tiers coupled thereto. In an illustrative embodiment, the set-top box devices **316**, **324** can access the IPTV system **300** via the access network **366**, using information received from the client gateway **350**. User devices can access the client gateway **350** via the access network **366**, and the client gateway **350** can allow such devices to access the private network **310** once the devices are authenticated or verified. Similarly, the client gateway **350** can prevent unauthorized devices, such as hacker computers or stolen set-top box devices from accessing the private network **310**, by denying access to these devices beyond the access network **366**.

For example, when the first representative set-top box device **316** accesses the client-facing tier **302** via the access network **366**, the client gateway **350** can verify subscriber information by communicating with the subscriber and system store **348** via the private network **310**. Further, the client gateway **350** can verify billing information and status by communicating with the OSS/BSS gateway **344** via the private network **310**. In one embodiment, the OSS/BSS gateway **344** can transmit a query via the public network **312** to the OSS/BSS server **364**. After the client gateway **350** confirms subscriber and/or billing information, the client gateway **350** can allow the set-top box device **316** to access IPTV content and VoD content at the client-facing tier **302**. If the client gateway **350** cannot verify subscriber information for the set-top box device **316**, because it is connected to an unauthorized twisted pair, the client gateway **350** can block transmissions to and from the set-top box device **316** beyond the access network **366**.

As indicated in FIG. 3, the acquisition tier **306** includes an acquisition tier (AQT) switch **352** that communicates with the private network **310**. The AQT switch **352** can also communicate with the operations and management tier **308** via the public network **312**. In a particular embodiment, the AQT switch **352** can be coupled to one or more live Acquisition-servers (A-servers) **354** that receive or acquire television content, movie content, advertisement content, other video content, or any combination thereof, from a broadcast service **356**, such as a satellite acquisition system or satellite head-end office. In a particular embodiment, the live acquisition server **354** can transmit content to the AQT switch **352**, and the AQT switch **352** can transmit the content to the CFT switch **330** via the private network **310**.

In an illustrative embodiment, content can be transmitted to the D-servers **332**, where it can be encoded, formatted, stored, replicated, or otherwise manipulated and prepared for communication from the video server(s) **380** to the set-top box devices **316**, **324**. The CFT switch **330** can receive content from the video server(s) **380** and communicate the content to the CPE **314**, **322** via the access network **366**. The set-top box devices **316**, **324** can receive the content via the CPE **314**, **322**, and can transmit the content to the television monitors **318**, **326**. In an illustrative embodiment, video or audio portions of the content can be streamed to the set-top box devices **316**, **324**.

Further, the AQT switch **352** can be coupled to a video-on-demand importer server **358** that receives and stores television or movie content received at the acquisition tier **306** and communicates the stored content to the VoD server **336** at the client-facing tier **302** via the private network **310**. Addition-

ally, at the acquisition tier **306**, the VoD importer server **358** can receive content from one or more VoD sources outside the IPTV system **300**, such as movie studios and programmers of non-live content. The VoD importer server **358** can transmit the VoD content to the AQT switch **352**, and the AQT switch **352**, in turn, can communicate the material to the CFT switch **330** via the private network **310**. The VoD content can be stored at one or more servers, such as the VoD server **336**.

When users issue requests for VoD content via the set-top box devices **316**, **324**, the requests can be transmitted over the access network **366** to the VoD server **336**, via the CFT switch **330**. Upon receiving such requests, the VoD server **336** can retrieve the requested VoD content and transmit the content to the set-top box devices **316**, **324** across the access network **366**, via the CFT switch **330**. The set-top box devices **316**, **324** can transmit the VoD content to the television monitors **318**, **326**. In an illustrative embodiment, video or audio portions of VoD content can be streamed to the set-top box devices **316**, **324**.

FIG. 3 further illustrates that the operations and management tier **308** can include an operations and management tier (OMT) switch **360** that conducts communication between the operations and management tier **308** and the public network **312**. In the embodiment illustrated by FIG. 3, the OMT switch **360** is coupled to a TV2 server **362**. Additionally, the OMT switch **360** can be coupled to an OSS/BSS server **364** and to a simple network management protocol monitor **386** that monitors network devices within or coupled to the IPTV system **300**. In a particular embodiment, the OMT switch **360** can communicate with the AQT switch **352** via the public network **312**.

The OSS/BSS server **364** may include a cluster of servers, such as one or more CPE data collection servers that are adapted to request and store operations systems data, such as performance data from the set-top box devices **316**, **324**. In an illustrative embodiment, the CPE data collection servers may be adapted to analyze performance data to identify a condition of a physical component of a network path associated with a set-top box device, to predict a condition of a physical component of a network path associated with a set-top box device, or any combination thereof.

In an illustrative embodiment, the live acquisition server **354** can transmit content to the AQT switch **352**, and the AQT switch **352**, in turn, can transmit the content to the OMT switch **360** via the public network **312**. In this embodiment, the OMT switch **360** can transmit the content to the TV2 server **362** for display to users accessing the user interface at the TV2 server **362**. For example, a user can access the TV2 server **362** using a personal computer **368** coupled to the public network **312**.

It should be apparent to one of ordinary skill in the art from the foregoing media communication system embodiments that other suitable media communication systems for distributing broadcast media content as well as peer-to-peer exchange of content can be applied to the present disclosure.

FIG. 4 depicts an illustrative embodiment of a communication system **400** employing an IP Multimedia Subsystem (IMS) network architecture. Communication system **400** can be overlaid or operably coupled with communication systems **100-300** as another representative embodiment of said communication systems.

The communication system **400** can comprise a Home Subscriber Server (HSS) **440**, a telephone Number Mapping (ENUM) server **430**, and network elements of an IMS network **450**. The IMS network **450** can be coupled to IMS compliant communication devices (CD) **401**, **402** or a Public Switched Telephone Network (PSTN) CD **403** using a Media

Gateway Control Function (MGCF) **420** that connects the call through a common PSTN network **460**.

IMS CDs **401**, **402** register with the IMS network **450** by contacting a Proxy Call Session Control Function (P-CSCF) which communicates with a corresponding Serving CSCF (S-CSCF) to register the CDs with an Authentication, Authorization and Accounting (AAA) supported by the HSS **440**. To accomplish a communication session between CDs, an originating IMS CD **401** can submit a Session Initiation Protocol (SIP INVITE) message to an originating P-CSCF **404** which communicates with a corresponding originating S-CSCF **406**. The originating S-CSCF **406** can submit the SIP INVITE message to an application server (AS) such as reference **410** that can provide a variety of services to IMS subscribers. For example, the application server **410** can be used to perform originating treatment functions on the calling party number received by the originating S-CSCF **406** in the SIP INVITE message.

Originating treatment functions can include determining whether the calling party number has international calling services, and/or is requesting special telephony features (such as *72 forward calls, *73 cancel call forwarding, *67 for caller ID blocking, and so on). Additionally, the originating S-CSCF **406** can submit queries to the ENUM system **430** to translate an E.164 telephone number to a SIP Uniform Resource Identifier (URI) if the targeted communication device is IMS compliant. If the targeted communication device is a PSTN device, the ENUM system **430** will respond with an unsuccessful address resolution and the S-CSCF **406** will forward the call to the MGCF **420** via a Breakout Gateway Control Function (BGCF) **419**.

When the ENUM server **430** returns a SIP URI, the SIP URI is used by an Interrogating CSCF (I-CSCF) **407** to submit a query to the HSS **440** to identify a terminating S-CSCF **414** associated with a terminating IMS CD such as reference **402**. Once identified, the I-CSCF **407** can submit the SIP INVITE to the terminating S-CSCF **414** which can call on an application server **411** similar to reference **410** to perform the originating treatment telephony functions described earlier. The terminating S-CSCF **414** can then identify a terminating P-CSCF **416** associated with the terminating CD **402**. The P-CSCF **416** then signals the CD **402** to establish communications. The aforementioned process is symmetrical. Accordingly, the terms "originating" and "terminating" in FIG. 4 can be interchanged.

FIG. 5 depicts an illustrative embodiment of a portal **530**. The portal **530** can be used for managing services of communication systems **100-400**. The portal **530** can be accessed by a Uniform Resource Locator (URL) with a common Internet browser such as Microsoft's Internet Explorer using an Internet-capable communication device such as references **108**, **116**, or **210** of FIGS. 1-2. The portal **530** can be configured to access a media processor such as references **106**, **204**, **206**, **316**, and **324** of FIGS. 1-3 and services managed thereby such as a Digital Video Recorder (DVR), an Electronic Programming Guide (EPG), VoD catalog, a personal catalog stored in the STB (such as personal videos, pictures, audio recordings, etc.), and so on.

FIG. 6 depicts an exemplary embodiment of a communication device **600**. Communication device **600** can be a representative portion of any of the aforementioned communication devices of FIGS. 1-4. The communication device **604** can comprise a wireline and/or wireless transceiver **602** (herein transceiver **602**), a user interface (UI) **604**, a power supply **614**, and a controller **606** for managing operations thereof. The transceiver **602** can support short-range or long-range wireless access technologies such as a Bluetooth wire-

less access protocol, a Wireless Fidelity (WiFi) access protocol, a Digital Enhanced Cordless Telecommunications (DECT) wireless access protocol, cellular, software defined radio (SDR) and/or WiMAX technologies, just to mention a few. Cellular technologies can include, for example, CDMA-1X, UMTS/HSDPA, GSM/GPRS, TDMA/EDGE, EV/DO, and next generation technologies as they arise.

The transceiver **602** can also support common wireline access technologies such as circuit-switched wireline access technologies, packet-switched wireline access technologies, or combinations thereof. PSTN can represent one of the common circuit-switched wireline access technologies. Voice over Internet Protocol (VoIP), and IP data communications can represent some of the commonly available packet-switched wireline access technologies. The transceiver **602** can also be adapted to support IP Multimedia Subsystem (IMS) protocol for interfacing to an IMS network that can combine PSTN and VoIP communication technologies.

The UI **604** can include a depressible or touch-sensitive keypad **608** and a navigation mechanism such as a roller ball, joystick, mouse, and/or navigation disk for manipulating operations of the communication device **600**. The keypad **608** can be an integral part of a housing assembly of the communication device **600** or an independent device operably coupled thereto by a tethered wiring interface (such as a USB) or a wireless interface supporting for example Bluetooth. The keypad **608** can represent a numeric dialing keypad commonly used by phones, and/or a Qwerty keypad with alphanumeric keys.

The UI **604** can further include a display **610** such as monochrome or color LCD (Liquid Crystal Display), OLED (Organic Light Emitting Diode) or other suitable display technology for conveying images to the end user of the communication device **600**. In an embodiment where the display **610** is touch-sensitive, a portion or all of the keypad **608** can be presented by way of the display. The UI **604** can also include an audio system **612** that utilizes common audio technology for conveying low volume audio (such as audio heard only in the proximity of a human ear) and high volume audio (such as speakerphone for hands free operation). The audio system **612** can further include a microphone for receiving audible signals of an end user.

The power supply **614** can utilize common power management technologies such as replaceable and rechargeable batteries, supply regulation technologies, and charging system technologies for supplying energy to the components of the communication device **600** to facilitate long-range or short-range portable applications. The controller **606** can utilize computing technologies such as a microprocessor and/or digital signal processor (DSP) with associated storage memory such as Flash, ROM, RAM, SRAM, DRAM or other storage technologies.

As noted above, broadcast television over IP is one service of IPTV. To efficiently deliver such broadcast TV in the network to users, IP multicast is used since it provides huge bandwidth efficiencies over unicast delivery. For national channels the IPTV streams are sent to every local market, independent of whether there are currently viewers in each local market for a particular channel. This is done to improve the channel change time latency. To accomplish this, static joins must be created on every edge delivery router in the network across all local markets. As more channels are added to the network, the state information grows. When nodes are added to the network or maintenance is performed that takes new nodes or links or when there are node or link failures, then the time to reroute the multicast traffic depends on the amount of multicast routing state present in the network.

Furthermore, pre-positioning multicast state in every local market edge router requires configuring static multicast joins in every one of the local market edge routers. This is a very large amount of configuration and it touches every router which can be an operational scale problem. The scale problem can thus occur every time new channel streams are added to the network. It is easy to miss a configuration because a node is unavailable or because of maintenance events that may remove or update configurations. Such continual activity as the number of edge elements increases leads to configuration errors and thus loss of service in the network. Such an arrangement also makes migration of the multicast delivery architecture to updated designs or new addressing difficult because of the amount of configuration that must be changed.

Using a multicast VPN to delivery national broadcast IPTV can eliminate many of the issues encountered. Multicast VPN means using a service such as MPLS VPNs that create carrier based private networks, such as a service AT&T offers to their enterprise customers. Such VPN services are used to provide isolation and privacy of individual networks and Quality of Service (QoS) for the individual customers. But contrary to the traditional goal of VPN services of providing isolation and privacy of a virtual network, the embodiments herein apply a multicast VPN service to eliminate multicast state in the backbone and eliminate the state multicast join configuration at each egress edge router in the local routers. Thus, embodiments herein can involve creating a multicast VPN across the backbone network. Every edge router (that connects to multicast clients whether caching servers or customers and to multicast sources) is treated as a provider edge (PE) router (commonly known in MPLS VPN terminology). A single VPN with a single multicast domain tree (MDT) can be created among these PE routers. In a multicast VPN, a single private multicast group can be used to create the MDT in the backbone, independent of the number of active external multicast groups. Further, every PE router can join this MDT without requiring knowledge of whether there are receivers for the multicast groups carried in the VPN. In a normal multicast VPN, the MDT creates inefficiencies by transmitting multicast packets to PE routers that may not have any receivers. However, for the broadcast IPTV application, every PE router requires that every channel be received, but such a system can eliminate the need to created static joins for each external multicast group on the PE router. Since only a single group is present in the backbone of the network, route state stays constant and convergence time is optimal. Furthermore, there is only a single VPN in the private IPTV backbone application. There are no other multicast VPNs that might contribute to state growth in this network as might be present in a retail VPN service with very large numbers and growth of customers.

Convergence for the national broadcast IPTV is constant in such a network since the multicast state is constant since only a single group is present. Also the only static multicast joins needed in the network are at the ingress PE routers where the sources are connected. No static joins are needed at the egress PE routers where the receivers are attached. Again, a problem that grows without bound and is a challenge operationally to maintain is substituted with a configuration where a single or bounded number of ingress PE routers exists.

FIG. 7 depicts an illustrative method 700 operating in portions of communication systems 100-400. Method 700 begins with step 702 in which delivery of national broadcast IPTV uses national multicast VPNs to deliver national broadcast channels by way of IPTV edge routers using an MPLS protocol and at 704 shares a same multicast state and shares a same multicast delivery tree for the national broadcast chan-

nels. At 706, the method can use MPLS VPNs that create carrier based private networks. The method can apply multicast VPN service to eliminate multicast state information in a backbone of a network and to eliminate state multicast join configuration information at each egress edge router in local routers at 708. The method 700 at 710 in this regard creates a multicast VPN across a backbone network. At 712, the method treats every edge router as a provider edge (PE) router where a single VPN with a single multicast domain tree (MDT) is created among the PE routers which eliminates static joins for each external multicast group on the PE. At 714, the PE routers can joint the MDT without requiring knowledge of whether there are receivers for the multicast groups carried in the VPN. At 716, the multicast state remains constant due to having a single multicast group. Thus, only static multicast joins are used in the network at ingress PE routers.

Upon reviewing the aforementioned embodiments, it would be evident to an artisan with ordinary skill in the art that said embodiments can be modified, reduced, or enhanced without departing from the scope and spirit of the claims described below. For example, VPNs other than MPLS VPNs can comprise the network or networks as contemplated herein.

Other suitable modifications can be applied to the present disclosure without departing from the scope of the claims below. Accordingly, the reader is directed to the claims section for a fuller understanding of the breadth and scope of the present disclosure.

FIG. 8 depicts an illustrative diagrammatic representation of a machine in the form of a computer system 800 within which a set of instructions, when executed, may cause the machine to perform any one or more of the methodologies discussed above. In some embodiments, the machine operates as a standalone device. In some embodiments, the machine may be connected (using a network) to other machines. In a networked deployment, the machine may operate in the capacity of a server or a client user machine in server-client user network environment, or as a peer machine in a peer-to-peer (or distributed) network environment.

The machine may comprise a server computer, a client user computer, a personal computer (PC), a tablet PC, a laptop computer, a desktop computer, a control system, a network router, switch or bridge, or any machine capable of executing a set of instructions (sequential or otherwise) that specify actions to be taken by that machine. It will be understood that a device of the present disclosure includes broadly any electronic device that provides voice, video or data communication. Further, while a single machine is illustrated, the term "machine" shall also be taken to include any collection of machines that individually or jointly execute a set (or multiple sets) of instructions to perform any one or more of the methodologies discussed herein.

The computer system 800 may include a processor 802 (such as a central processing unit (CPU)), a graphics processing unit (GPU, or both), a main memory 804 and a static memory 806, which communicate with each other via a bus 808. The computer system 800 may further include a video display unit 810 (such as a liquid crystal display (LCD)), a flat panel, a solid state display, or a cathode ray tube (CRT)). The computer system 800 may include an input device 812 (such as a keyboard), a cursor control device 814 (such as a mouse), a disk drive unit 816, a signal generation device 818 (such as a speaker or remote control) and a network interface device 820.

The disk drive unit 816 may include a computer-readable medium 822 on which is stored one or more sets of instruc-

tions (such as software **824**) embodying any one or more of the methodologies or functions described herein, including those methods illustrated above. The instructions **824** may also reside, completely or at least partially, within the main memory **804**, the static memory **806**, and/or within the processor **802** during execution thereof by the computer system **800**. The main memory **804** and the processor **802** also may constitute computer-readable media.

Dedicated hardware implementations including, but not limited to, application specific integrated circuits, programmable logic arrays and other hardware devices can likewise be constructed to implement the methods described herein. Applications that may include the apparatus and systems of various embodiments broadly include a variety of electronic and computer systems. Some embodiments implement functions in two or more specific interconnected hardware modules or devices with related control and data signals communicated between and through the modules, or as portions of an application-specific integrated circuit. Thus, the example system is applicable to software, firmware, and hardware implementations.

In accordance with various embodiments of the present disclosure, the methods described herein are intended for operation as software programs running on a computer processor. Furthermore, software implementations can include, but not limited to, distributed processing or component/object distributed processing, parallel processing, or virtual machine processing can also be constructed to implement the methods described herein.

The present disclosure contemplates a machine readable medium containing instructions **824**, or that which receives and executes instructions **824** from a propagated signal so that a device connected to a network environment **826** can send or receive voice, video or data, and to communicate over the network **826** using the instructions **824**. The instructions **824** may further be transmitted or received over a network **826** via the network interface device **820**.

While the computer-readable medium **822** is shown in an example embodiment to be a single medium, the term "computer-readable medium" should be taken to include a single medium or multiple media (such as a centralized or distributed database, and/or associated caches and servers) that store the one or more sets of instructions. The term "computer-readable medium" shall also be taken to include any medium that is capable of storing, encoding or carrying a set of instructions for execution by the machine and that cause the machine to perform any one or more of the methodologies of the present disclosure.

The term "computer-readable medium" shall accordingly be taken to include, but not be limited to: solid-state memories such as a memory card or other package that houses one or more read-only (non-volatile) memories, random access memories, or other re-writable (volatile) memories; magneto-optical or optical medium such as a disk or tape; and/or a digital file attachment to e-mail or other self-contained information archive or set of archives is considered a distribution medium equivalent to a tangible storage medium. Accordingly, the disclosure is considered to include any one or more of a computer-readable medium or a distribution medium, as listed herein and including art-recognized equivalents and successor media, in which the software implementations herein are stored.

Although the present specification describes components and functions implemented in the embodiments with reference to particular standards and protocols, the disclosure is not limited to such standards and protocols. Each of the standards for Internet and other packet switched network

transmission (such as TCP/IP, UDP/IP, HTML, HTTP) represent examples of the state of the art. Such standards are periodically superseded by faster or more efficient equivalents having essentially the same functions. Accordingly, replacement standards and protocols having the same functions are considered equivalents.

The illustrations of embodiments described herein are intended to provide a general understanding of the structure of various embodiments, and they are not intended to serve as a complete description of all the elements and features of apparatus and systems that might make use of the structures described herein. Many other embodiments will be apparent to those of skill in the art upon reviewing the above description. Other embodiments may be utilized and derived therefrom, such that structural and logical substitutions and changes may be made without departing from the scope of this disclosure. Figures are also merely representational and may not be drawn to scale. Certain proportions thereof may be exaggerated, while others may be minimized. Accordingly, the specification and drawings are to be regarded in an illustrative rather than a restrictive sense.

Such embodiments of the inventive subject matter may be referred to herein, individually and/or collectively, by the term "invention" merely for convenience and without intending to voluntarily limit the scope of this application to any single invention or inventive concept if more than one is in fact disclosed. Thus, although specific embodiments have been illustrated and described herein, it should be appreciated that any arrangement calculated to achieve the same purpose may be substituted for the specific embodiments shown. This disclosure is intended to cover any and all adaptations or variations of various embodiments. Combinations of the above embodiments, and other embodiments not specifically described herein, will be apparent to those of skill in the art upon reviewing the above description.

The Abstract of the Disclosure is provided to allow the reader to quickly ascertain the nature of the technical disclosure. It is submitted with the understanding that it will not be used to interpret or limit the scope or meaning of the claims. In addition, in the foregoing Detailed Description, it can be seen that various features are grouped together in a single embodiment for the purpose of streamlining the disclosure. This method of disclosure is not to be interpreted as reflecting an intention that the claimed embodiments require more features than are expressly recited in each claim. Rather, as the following claims reflect, inventive subject matter lies in less than all features of a single disclosed embodiment. Thus the following claims are hereby incorporated into the Detailed Description, with each claim standing on its own as a separately claimed subject matter.

What is claimed is:

1. A method, comprising:

providing a first group of routers of a television system with static multicast join configuration information without providing a second group of routers of the television system with the static multicast join configuration information;

delivering national broadcast channels via a multicast virtual private network, wherein the multicast virtual private network utilizes the first and second groups of routers to deliver the national broadcast channels and utilizes a multi-protocol label switching protocol to deliver the national broadcast channels;

sharing a same multicast state and a same multicast delivery tree for the national broadcast channels; and

maintaining a static number of the first group of routers for the multicast virtual private network.

15

2. The method of claim 1, wherein the second group of routers includes only egress edge routers and wherein at least one of the egress edge routers is connected to a caching server, and wherein the sharing of the same multicast state and the same multicast delivery tree is performed by transmitting multicast data via the multi-protocol label switching protocol to selected network elements.

3. The method of claim 2, wherein the first group of routers includes only ingress edge routers.

4. The method of claim 1, wherein the second group of routers join a multicast domain tree without receiving information indicating whether there are receivers for multicast groups carried in the multicast virtual private network, and wherein the sharing of the same multicast state and the same multicast delivery tree is performed by transmitting multicast data via the multi-protocol label switching protocol to selected network elements.

5. The method of claim 1, wherein the delivering of the national broadcast channels is performed by creating a single multicast domain tree among the first and second groups of routers.

6. The method of claim 5, wherein the second group of routers join the multicast domain tree without receiving information indicating whether there are receivers for multicast groups carried in the multicast virtual private network.

7. A non-transitory computer-readable storage device, comprising computer instructions, which when executed by a processor causes the processor to perform operations comprising:

delivering broadcast channels using a multicast virtual private network, wherein the multicast virtual private network utilizes a first group of routers provisioned with static multicast join configuration information, and wherein the multicast virtual private network utilizes a second group of routers that are provisioned without the static multicast join configuration information;

sharing a multicast state for the broadcast channels with selected network elements; and

maintaining a static number of the first group of routers for the multicast virtual private network.

8. The non-transitory computer-readable storage device of claim 7, wherein responsive to executing the computer instructions, the processor applies a multi-protocol label switching protocol to the multicast virtual private network to distribute data that provides for the sharing of the multicast state for the broadcast channels.

9. The non-transitory computer-readable storage device of claim 7, wherein responsive to executing the computer instructions, the processor creates a single multicast domain tree among the first and second groups of routers.

10. The non-transitory computer-readable storage device of claim 7, wherein the second group of routers includes only egress edge routers and wherein at least one of the egress edge routers is connected to a caching server.

11. The non-transitory computer-readable storage device of claim 7, wherein the second group of routers join a multicast domain tree without receiving information indicating whether there are receivers for multicast groups carried in the multicast virtual private network, and wherein the sharing of

16

the multicast state is performed by transmitting multicast data via a multi-protocol label switching protocol to selected network elements.

12. The non-transitory computer-readable storage device of claim 7, wherein the first and second groups of routers are edge routers.

13. The non-transitory computer-readable storage device of claim 12, wherein the edge routers include provider edge routers and customer edge routers, and wherein a single multicast domain tree is created among the edge routers.

14. The non-transitory computer-readable storage device of claim 13, wherein egress edge routers of the second group of routers join the single multicast domain tree without receiving information indicating whether there are receivers for multicast groups carried in the multicast virtual private network.

15. The non-transitory computer-readable storage device of claim 7, wherein only static multicast joins are used in the multicast virtual private network at the first group of routers.

16. A system, comprising:

a memory having computer instructions; and
a controller coupled to the memory, wherein executing the computer instructions causes the controller to perform operations comprising:

delivering broadcast content using a multicast virtual private network, wherein the multicast virtual private network utilizes a first group of routers provisioned with static multicast join configuration information, and wherein the multicast virtual private network utilizes a second group of routers that are provisioned without the static multicast join configuration information;

sharing a same multicast state for the broadcast content; sharing a same multicast delivery tree for the broadcast content; and

maintaining a static number of the first group of routers for the multicast virtual private network.

17. The system of claim 16, wherein executing the computer instructions causes the controller to perform operations comprising applying a multi-protocol label switching protocol for the multicast virtual private network, and wherein the broadcast content is delivered over an interactive Television system comprising at least one of an internet protocol television communication system, a cable Television communication system, or a satellite Television communication system.

18. The system of claim 16, wherein the second group of routers includes only egress edge routers, wherein at least one of the egress edge routers is connected to a caching server, and wherein the first group of routers includes only ingress edge routers.

19. The system of claim 16, wherein the second group of routers join a multicast domain tree without receiving information indicating whether there are receivers for multicast groups carried in the multicast virtual private network, and wherein the sharing of the multicast state is performed by transmitting multicast data via a multi-protocol label switching protocol to selected network elements.

20. The system of claim 16, wherein only static multicast joins are used in the multicast virtual private network at the first group of routers.

* * * * *