

(19) World Intellectual Property  
Organization  
International Bureau



(43) International Publication Date  
18 March 2004 (18.03.2004)

PCT

(10) International Publication Number  
WO 2004/022498 A1

- (51) International Patent Classification<sup>7</sup>: C03C 17/22, A45D 42/08, 34/06
- (21) International Application Number: PCT/US2003/027217
- (22) International Filing Date: 2 September 2003 (02.09.2003)
- (25) Filing Language: English
- (26) Publication Language: English
- (30) Priority Data: 02256122.9 3 September 2002 (03.09.2002) EP
- (71) Applicant: THE PROCTER & GAMBLE COMPANY [US/US]; One Procter & Gamble Plaza, Cincinnati, OH 45202 (US).
- (72) Inventor: HILL, Simon, David, Julian; Woodcroft, Dartnell Avenue, West Byfleet, Surrey KT14 6PH (GB).
- (74) Agents: REED, T., David et al.; The Procter & Gamble Company, 6110 Center Hill Road, Cincinnati, OH 45224 (US).
- (81) Designated States (*national*): AE, AG, AL, AM, AT (utility model), AT, AU, AZ, BA, BB, BG, BR, BY, BZ, CA, CH, CN, CO, CR, CU, CZ (utility model), CZ, DE (utility model), DE, DK (utility model), DK, DM, DZ, EC, EE (utility model), EE, ES, FI (utility model), FI, GB, GD, GE, GH, GM, HR, HU, ID, IL, IN, IS, JP, KE, KG, KP, KR, KZ, LC, LK, LR, LS, LT, LU, LV, MA, MD, MG, MK, MN, MW, MX, MZ, NI, NO, NZ, OM, PG, PH, PL, PT, RO, RU, SC, SD, SE, SG, SK (utility model), SK, SL, SY, TJ, TM, TN, TR, TT, TZ, UA, UG, UZ, VC, VN, YU, ZA, ZM, ZW.
- (84) Designated States (*regional*): ARIPO patent (GH, GM, KE, LS, MW, MZ, SD, SL, SZ, TZ, UG, ZM, ZW), Eurasian patent (AM, AZ, BY, KG, KZ, MD, RU, TJ, TM), European patent (AT, BE, BG, CH, CY, CZ, DE, DK, EE,

[Continued on next page]

(54) Title: FLUID DISPENSER WITH ANTI-FOGGING MIRROR

(57) Abstract: A fluid dispenser comprising an anti-fogging mirror for use in environments that usually result in visible water condensate formation on mirrored surfaces is provided.

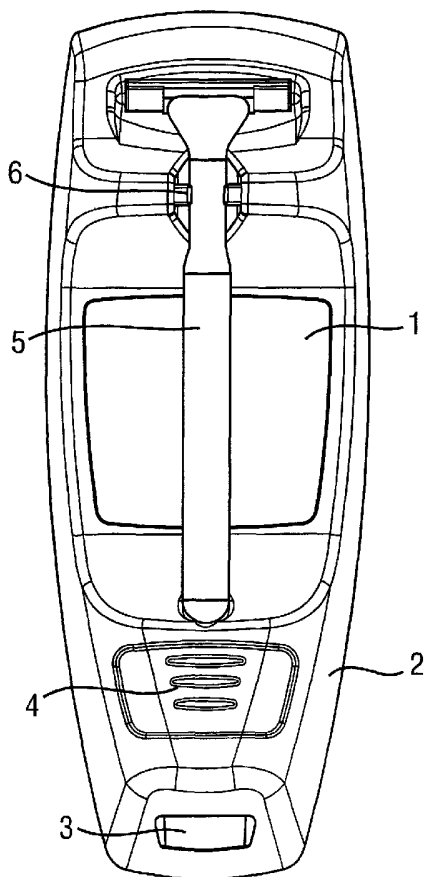

WO 2004/022498 A1



ES, FI, FR, GB, GR, HU, IE, IT, LU, MC, NL, PT, RO, SE, SI, SK, TR), OAPI patent (BF, BJ, CF, CG, CI, CM, GA, GN, GQ, GW, ML, MR, NE, SN, TD, TG).

**Declarations under Rule 4.17:**

— as to applicant's entitlement to apply for and be granted a patent (Rule 4.17(ii)) for the following designations AE, AG, AL, AM, AT, AU, AZ, BA, BB, BG, BR, BY, BZ, CA, CH, CN, CO, CR, CU, CZ, DE, DK, DM, DZ, EC, EE, ES, FI, GB, GD, GE, GH, GM, HR, HU, ID, IL, IN, IS, JP, KE, KG, KP, KR, KZ, LC, LK, LR, LS, LT, LU, LV, MA, MD, MG, MK, MN, MW, MX, MZ, NI, NO, NZ, OM, PG, PH, PL, PT, RO, RU, SC, SD, SE, SG, SK, SL, SY, TJ, TM, TN, TR, TT, TZ, UA, UG, UZ, VC, VN, YU, ZA, ZM, ZW, ARIPO patent (GH, GM, KE, LS, MW, MZ, SD, SL, SZ, TZ, UG,

ZM, ZW), Eurasian patent (AM, AZ, BY, KG, KZ, MD, RU, TJ, TM), European patent (AT, BE, BG, CH, CY, CZ, DE, DK, EE, ES, FI, FR, GB, GR, HU, IE, IT, LU, MC, NL, PT, RO, SE, SI, SK, TR), OAPI patent (BF, BJ, CF, CG, CI, CM, GA, GN, GQ, GW, ML, MR, NE, SN, TD, TG)

— as to the applicant's entitlement to claim the priority of the earlier application (Rule 4.17(iii)) for all designations

**Published:**

— with international search report

For two-letter codes and other abbreviations, refer to the "Guidance Notes on Codes and Abbreviations" appearing at the beginning of each regular issue of the PCT Gazette.

## FLUID DISPENSER WITH ANTI-FOGGING MIRROR

### FIELD

The present invention relates to the field of cosmetic fluid dispensers.

### BACKGROUND

It is recognised that whilst showering or bathing consumers may wish to dispense various fluids such as shaving foam or facial creams for application to the body, especially the face. A fluid dispenser with integrated mirror would enable application of the fluid and subsequent activities to be undertaken in the confines of the showering or bathing area. However, due to the inherent humidity of the environment, a visible layer of water condensate may form, causing mirrors to become "fogged", making it difficult to apply fluids to the face and to carry out subsequent activities, especially shaving.

It is known that mirrors may be de-fogged by means of passing heated water across the back of the mirror thereby elevating the temperature of the mirror to at least that of the surrounding environment and preventing condensation – see, for example, US 4,733,468. Such devices require complex plumbing arrangements attached to the non-mirrored surface of the mirror, and/or containers for storing volumes of heated water in contact with the non-mirrored surface. Additionally, these devices require connection to, or supply of, heated water, limiting their application and use.

Examples exist of mirrors with anti-fogging properties that result from the physical or chemical modification of the mirrored surface. US 4,400,157 teaches that a mirror may be rendered anti-fogging by the repeated application of a solution of 0.1% (v/v) dimethyl benzyl ammonium chloride. WO01/73483 A1 describes the use of a nylon pad to generate a static field across the surface of a hand-held mirror that results in the mirror having temporary anti-fogging properties. Both of these treatments are extremely short lived, resulting in the mirror rapidly losing its anti-fogging properties, thereby necessitating the frequent re-administration of the treatment. As a result, these treatments are not suitable for production of a permanently anti-fogging product.

Based on the foregoing, there is a need for a fluid dispenser having a permanent antifogging mirror.

### SUMMARY

The present invention is directed towards a fluid dispenser comprising an anti-fogging mirror.

Herein, "fluid" includes flowable materials such as liquids, gels, powders and pastes.

Herein, an "anti-fogging mirror" includes mirrors, the reflective surface of which, has been treated, for example by coating with a film of treatment material, so as to permanently reduce the formation of visible water condensate on the treated surfaces compared with the untreated material, whereby the treatment does not measurably impair the reflective properties of the surface.

As used herein, the word "permanent" when used in relation to the ability to reduce formation of visible water condensate, includes treatments that result in the anti-fogging properties remaining substantially undiminished for at least the usable life-span of the product, preferably for at least 1 year, more preferably at least 3 years.

The art of which the present inventors are aware appears to have ignored the possibility of providing a dispenser with an anti-fogging mirror, preferring to address issues, such as shaving in humid environments, by providing permanently plumbed-in devices as discussed hereinabove. The advantages of the present invention are manifold – it is very portable, so may be taken anywhere and used in humid environments where no anti-fogging mirror is present. It may also be placed in places such as a shower in which it would otherwise be very difficult to provide a permanent anti-fogging mirror.

According to a preferred embodiment, the present invention may further comprise a fluid dispenser wherein said anti-fogging mirror is coated by a nanoparticle film to provide anti-fogging properties. Advantageously, the coating may comprise natural clay, synthetic clay or a mixture of these materials.

Herein, "nanoparticle" includes a film comprising one or more particulate materials, wherein the particles preferably have a diameter of 400nm or less, more preferably from about 1 nm to about 400 nm. The particulate materials may comprise metal oxides, silicates, carbonates, hydroxides or mixtures thereof, such as natural clay and synthetic clay.

According to another preferred embodiment, the anti-fogging mirror is releasably attached to the fluid dispenser.

According to another preferred embodiment, the anti-fogging mirror is curved to enable magnification of viewing area.

According to another preferred embodiment, the fluid dispenser comprises means to attach the fluid dispenser to a surface, especially a wall or shower unit.

According to another preferred embodiment, the fluid dispenser additionally comprises means to attach a razor thereto.

According to another preferred embodiment, the fluid dispenser additionally comprises means for storing spare razor heads.

According to another preferred embodiment, the fluid dispenser comprises means to separately contain and dispense two or more types of fluid.

According to another preferred embodiment the fluid dispenser comprises means to separately contain and dispense two or more types of fluid and mix the fluids together upon dispensing.

These and other features, aspects, and advantages of the present invention will become evident to those skilled in the art from a reading of the present disclosure.

### BRIEF DESCRIPTION OF THE DRAWINGS

While the specification concludes with claims which particularly point out and distinctly claim the invention, it is believed the present invention will be better understood from the following description of preferred embodiments taken in

conjunction with the accompanying drawings, in which like reference numerals identify identical elements and in which:

Fig. 1 illustrates a front elevation of a preferred embodiment of the present invention.

Fig. 2 illustrates a side elevation of the embodiment of figure 1.

Fig. 3 illustrates an angled perspective view of the embodiment of figure 1.

Fig. 4 illustrates a top elevation of the embodiment of figure 1.

Fig. 5. illustrates a bottom elevation of the embodiment of figure 1.

### DETAILED DESCRIPTION

All cited references are incorporated herein by reference in their entireties.

Except where specific examples of actual measured values are presented, numerical values referred to herein should be considered to be qualified by the word "about".

The fluid dispenser of the present invention may have any size and shape to allow the storage and dispensing of contained fluids. In the case of a cosmetic fluid, the volume of the container will typically not exceed 1000ml, preferable not more than 500ml and more preferably not more than 400ml. The fluid dispenser may be constructed from man-made or natural materials. The man-made materials may comprise metal, including metal alloys, synthetic polymers or mixtures of these. Preferred polymeric materials include high density polyethylene, low density polyethylene, polypropylene, polyethylene terephthalate and mixtures of these. Preferred manufacturing techniques for the container include injection moulding, blow moulding and combinations thereof. In addition, the dispenser may be configured to contain pressurized fluids, i.e. at pressures above atmospheric pressure. It may, for example be configured as an aerosols canister.

The fluid dispenser of the present invention may comprise any fluid, such as liquids, gels, powders and pastes or a mixture of these. Preferably, the dispenser comprises one or more cosmetic fluids, selected from shaving foam,

shaving gel, skin lotion, body wash, dentifrice, and other cleansing or cosmetic fluids. More preferably, the dispenser comprises shaving foam.

The present invention may comprise more than one fluid held discretely within separate containers within the fluid dispenser. The fluid dispenser may be configured to dispense these fluids separately, both spatially and temporally, or just spatially, or in a way that effects mixing on expulsion from the dispensing orifice.

The fluid dispenser of the present invention may comprise control means for preventing and controlling the release of fluids through the dispensing orifice. These control means may comprise a valve, a cap or both. Furthermore, flow control may be achieved by a combination of a high viscosity fluid, a small dispensing orifice and the application of pressure to overcome the inability of the fluid to pass through the orifice under the influence of gravity alone. In the event that the control means comprise a valve, the valve may be a ball valve, a tap valve, spring valve or a silicone slit valve. Preferably, the control means comprise a silicone slit valve. The valve may be housed in a plastic closure and screwed or snap-fitted to the dispenser. The valve may also be co-moulded into the container during manufacturing. In the event that the flow control means comprise a cap, the cap may be fixedly or releasably attached to the fluid dispenser. If fixedly attached, it may be attached by means of a hinge or attached via a snap-fit.

Fluid dispensing may be achieved by a number of methods. These methods include gravity. In this case, the dispensing orifice will be oriented, in use, to face downwards and flow control will typically be by means of a cap and/or a valve. A further method includes application of external pressure. In such a case, the dispenser may be manufactured, at least in part, of flexible material allowing a user to squeeze it and force out fluid. Alternatively or in addition, the dispenser may comprise a pump. The pump may be operated by a push button or push zone. In this case, flow control may be achieved by varying the application pressure. Alternatively or additionally, flow control may be achieved by means of a cap and/or a valve. A further method of dispensing fluid

is by release of pressure in the case where the dispenser is pressurized, such as by depressing an aerosol nozzle.

The fluid dispenser of the present invention comprises an anti-fogging mirror. The mirror may comprise reflective material such as metal, metallised glass, metallised plastic, other reflective plastic or a mixture of these materials. The mirror may comprise one continuous piece of reflective material or an arrangement of multiple sections of such material, but preferably comprises one continuous piece. The mirror may have any shape that enables a consumer to use it for the intended purpose, such as shaving - examples include circular, oval, rectangular and other polygonal shapes. The total reflective area of the mirror is preferably from about 2 cm<sup>2</sup> to about 300 cm<sup>2</sup>, more preferably from about 4 cm<sup>2</sup> to about 100 cm<sup>2</sup>, more preferably still from about 8 cm<sup>2</sup> to about 50 cm<sup>2</sup>, and yet more preferably more than or equal to 9 cm<sup>2</sup>. The anti-fogging mirror may be rigid or flexible.

Examples of anti-fogging treatments include:

- a) Application of a hydrophilic nanoparticle film is disclosed in US 02/0045010 A1. The nanoparticles may comprise metal oxides, silicates, carbonates, hydroxides, or mixtures thereof such as natural clays and synthetic clays. The particles preferably have a diameter of 400nm or less, more preferably from about 1 nm to about 400 nm. Advantageously, the nanoparticles are in the form of synthetic clays. More advantageously, the nanoparticles are in the form of synthetic hectorite, such as Laponite™ from Southern Clay Products Inc., which has the formula:

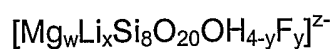

where  $w = 3$  to  $6$ ,  $x = 0$  to  $3$ ,  $y = 0$  to  $4$ ,  $z = 12 - 2w - x$  and the overall negative lattice charge is balanced by counter ions; and wherein the counter-ions are selected from the group consisting of selected  $\text{Na}^+$ ,  $\text{K}^+$ ,  $\text{NH}_4^+$ ,  $\text{Cs}^+$ ,  $\text{Li}^+$ ,  $\text{Mg}^{++}$ ,  $\text{Ca}^{++}$ ,  $\text{Ba}^{++}$ ,  $\text{N}(\text{CH}_3)^+$  and mixtures thereof.



Advantageously, the substantivity of the nanoparticles is increased by heat curing, as disclosed in US2002/0028288 A1.

- b) Application of a combination of photocatalytic metallic oxide, silica- or silicone resin- film forming precursors and solvents as disclosed in US 6,165,256.
- c) Film coatings of polyurethane and hydrophilic polyacrylic as disclosed in US 3,935,367.
- d) Application of combinations of hydroxyalkyl acrylate or methylacrylate and organosiloxane-oxyalkylene block copolymers as disclosed in US 3,933,407.
- e) Application of a transparent label films impregnated with surfactants.
- f) Application of colloidal silica particles, colloidal alumina particles or mixtures thereof, as disclosed in EP 0 052 427.

As far as the present inventor is aware, these treatments have not previously been used on mirrors.

The anti-fogging mirror may be incorporated into the fluid dispenser such that it is fixedly or releasably attached. Fixed attachment of the mirror may be achieved by moulding the fluid dispenser out of one piece of plastic, gluing the mirror to the fluid dispenser or heat-sealing the mirror to the fluid dispenser. Moulding allows the fluid dispenser to be made as one whole unit.

Means for releasably attaching the mirror to the dispenser may comprise hinges, clasps, clips and sliding grooves on the fluid dispenser. This allows the mirror to be sold separately and then transferred from one fluid dispenser to another.

Where the means for attaching the mirror to the dispenser comprises a hinge, the mirror may be attached such that the hinge is positioned on any side of the fluid dispenser, preferably at the end of the dispenser opposite to the end which comprises the dispensing orifice. The hinge may allow the mirror to be moved such that the reflective surface is not visible (i.e. "closed") to protect the mirror when in transit, or not in use. During use, the mirror can be opened via rotation around the hinge so that the reflective surface is visible. In addition, this may allow graphics, designs, holograms and the like to be placed on the non-reflective reverse side of the mirror. Alternatively, the mirror may comprise two reflective surfaces opposite one another on a first and second side, the first side reflecting a normal image, the second reflecting a magnified image, the hinge attachment enabling the user to switch between the two mirror types easily.

The anti-fogging mirror may also be curved or partially curved, preferably with concave curvature allowing magnification of the viewing area, thereby facilitating more accurate shaving, for example.

The fluid dispenser of the present invention may further include means of attachment to a surface, preferably a wall or shower unit. The attachment means may comprise a rubber suction cup, adhesive strips, adhesive foam pads, rope or plastic tang for hanging from a hook, or screw fixtures. Preferably the attachment means comprise a suction cup. Attachment means enable the fluid dispenser to be placed on a wall within the shower or bath area at a height that enables the consumer to view his or her reflection most efficiently. It also results in the consumer having both hands free to undertake tasks, such as shaving.

The fluid dispenser of the present invention may comprise means of attaching for a razor thereto. These may comprise a hook, a clasp or a stand, preferably a clasp.

Furthermore, the fluid dispenser of the present invention may comprise means for storing spare razor heads, such as clips, clasps, racks and dispensing racks. Preferably, the storage means comprises a dispensing rack.

The fluid dispenser of the present invention may also be provided in a kit form. The kit comprises a fluid dispenser and an anti-fogging mirror as herein described. Preferably, the anti-fogging mirror comprises means for attachment to the fluid dispenser, such as a hinge or clasp. Alternatively, or in addition, the anti-fogging mirror may comprise means for attachment to a surface, such as a rubber suction cup or adhesive tape. The anti-fogging mirror may further comprise means for stably supporting the mirror on a horizontal surface, such as a stand or other similar device. The kit may further comprise additional elements such as a razor, spare razor blades, additional fluid containers comprising the fluid present in the fluid dispenser, or different fluids.

The following example further describes and demonstrates a preferred embodiment within the scope of the present invention. The example is given solely for the purpose of illustration, and is not to be construed as a limitation of the present invention since many variations thereof are possible without departing from its scope.

#### Example 1

With reference to figures 1 to 4, a fluid dispenser comprising an anti-fogging mirror (1) is presented. The anti-fogging mirror (1) comprises a piece of reflective plastic with an area of 9 cm<sup>2</sup> that is coated with a hydrophilic nanoclay. The mirror is glued to the fluid dispenser. The dispenser is moulded from polypropylene and has approximate dimensions of 12 cm along the longitudinal axis, 4 cm in width and 2 cm in depth. The fluid is contained within the fluid container (2) and is dispensed through the dispensing orifice (3). The dispensing of the fluid through the dispensing orifice (3) is effected and controlled by the push button (4). A razor (5) is presented attached to the fluid dispenser via the razor clasp (6). Once the razor is removed for use, the anti-fogging mirror (1) is unobstructed. A suction cup (7) for attaching the fluid dispenser to a surface is provided.

It is understood that the examples and embodiments described herein are for illustrative purposes only and that various modifications or changes in light thereof will be suggested to one skilled in the art without departing from the scope of the present invention.

## WHAT IS CLAIMED IS:

1. A fluid dispenser comprising an anti-fogging mirror.
2. A fluid dispenser according to claim 1, wherein said anti-fogging mirror is coated with a nanoparticle film to provide anti-fogging properties.
3. A fluid dispenser according to claim 2, wherein the nanoparticle film comprises natural clay, synthetic clay or a mixture of these materials.
4. A fluid dispenser according to any one of the preceding claims wherein said anti-fogging mirror is releasably attached to the fluid dispenser.
5. A fluid dispenser according to any one of the preceding claims wherein said anti-fogging mirror is curved to enable magnification of the viewing area.
6. A fluid dispenser according to any one of the preceding claims comprising means to attach the fluid dispenser to a surface, especially a wall or shower unit.
7. A fluid dispenser according to any one of the preceding claims comprising means to attach a razor thereto.
8. A fluid dispenser according to any one of the preceding claims comprising means for storing spare razor heads.
9. A fluid dispenser according to any one of the preceding claims comprising the means to separately contain and dispense two or more types of fluid.
10. A fluid dispenser according to claim 9 comprising means to mix the two or more fluids upon dispensing.
11. A kit comprising a fluid dispenser and an anti-fogging mirror.

1/4

FIG. 1

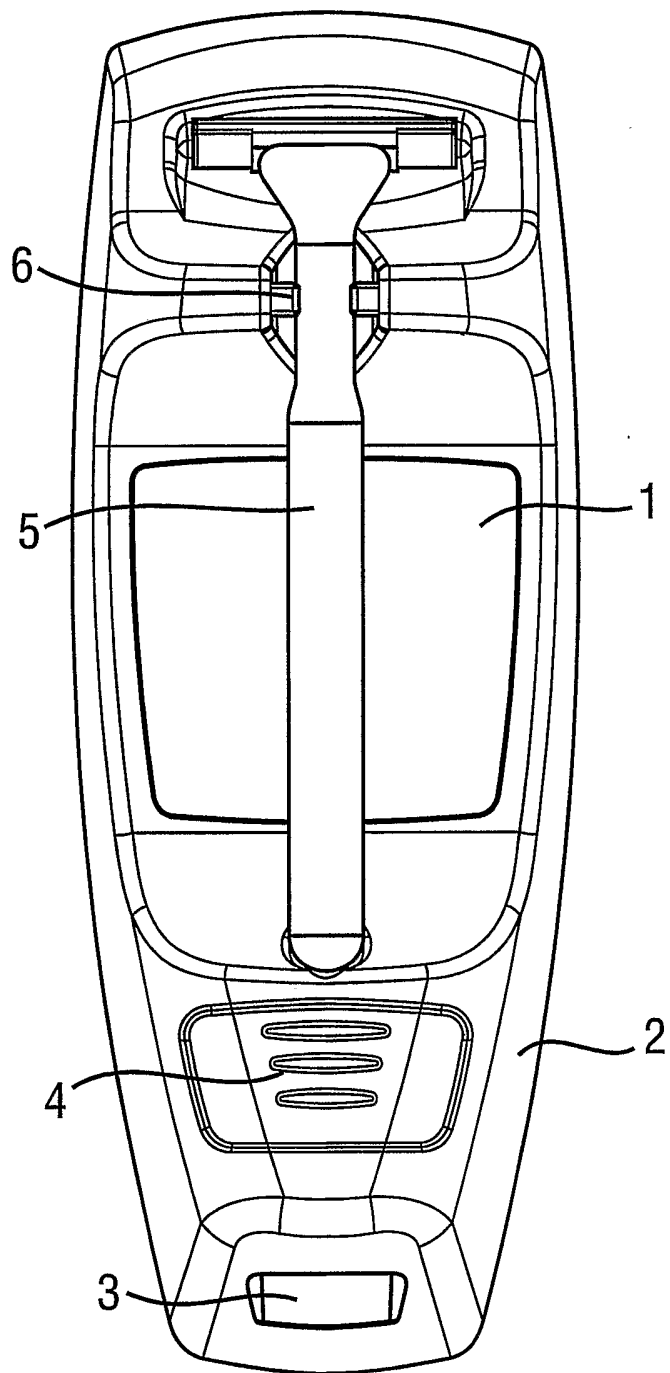
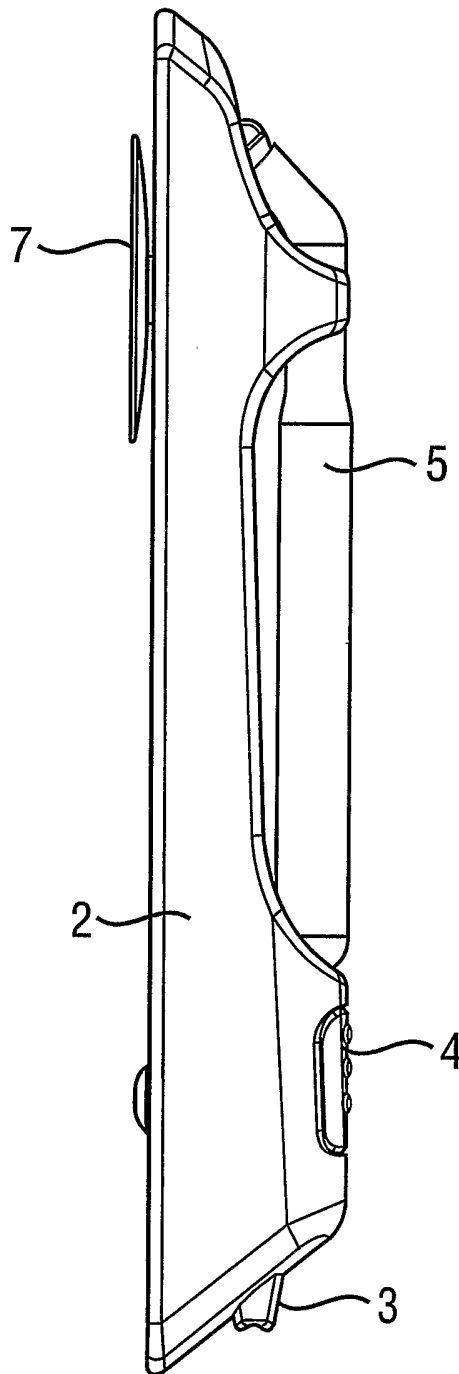

FIG. 2



3/4

FIG. 3

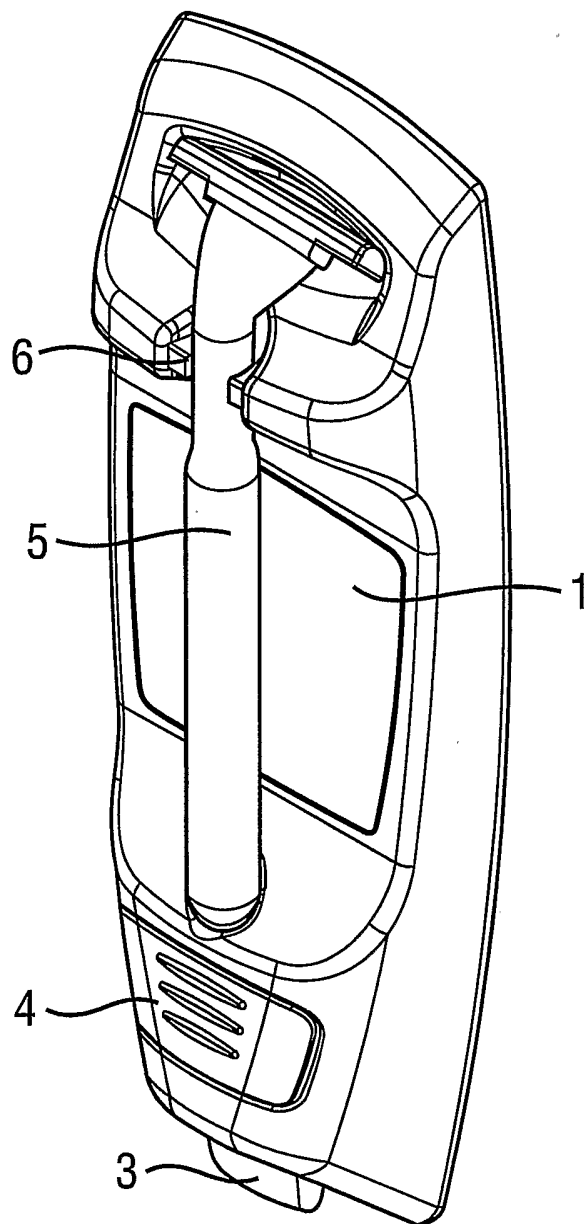

FIG. 4

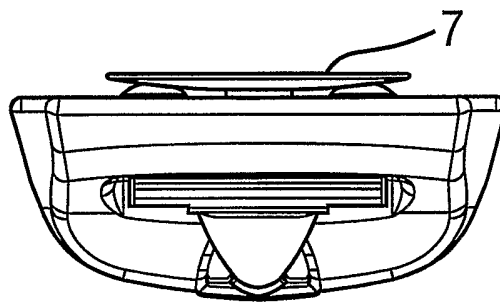
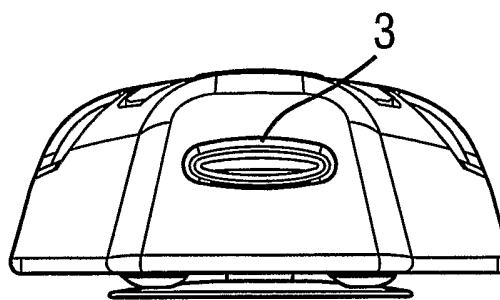

FIG. 5





# INTERNATIONAL SEARCH REPORT

Internat      pplication No  
PCT/US 03/27217

<b>A. CLASSIFICATION OF SUBJECT MATTER</b> IPC 7    C03C17/22    A45D42/08    A45D34/06		
According to International Patent Classification (IPC) or to both national classification and IPC		
<b>B. FIELDS SEARCHED</b>		
Minimum documentation searched (classification system followed by classification symbols) IPC 7    C03C    A45D		
Documentation searched other than minimum documentation to the extent that such documents are included in the fields searched		
Electronic data base consulted during the international search (name of data base and, where practical, search terms used) EPO-Internal, PAJ		
<b>C. DOCUMENTS CONSIDERED TO BE RELEVANT</b>		
Category °	Citation of document, with indication, where appropriate, of the relevant passages	Relevant to claim No.
Y	US 4 481 962 A (PESTA RICHARD K) 13 November 1984 (1984-11-13)	1-3,5
X	the whole document	4,7-11
Y	US 5 230 444 A (DUNBAR WILLIAM J) 27 July 1993 (1993-07-27)	1-3,5
X	the whole document	4,6,9,11
Y	US 4 248 398 A (DOYEL JOHN S) 3 February 1981 (1981-02-03)	1-3,5
X	the whole document	4,6,9,11
Y	PATENT ABSTRACTS OF JAPAN vol. 1997, no. 07, 31 July 1997 (1997-07-31) -& JP 09 056549 A (TOTO LTD), 4 March 1997 (1997-03-04) abstract	1-3
--- -/--		
<input checked="" type="checkbox"/> Further documents are listed in the continuation of box C.		
<input checked="" type="checkbox"/> Patent family members are listed in annex.		
° Special categories of cited documents :		
*A* document defining the general state of the art which is not considered to be of particular relevance		
*E* earlier document but published on or after the international filing date		
*L* document which may throw doubts on priority claim(s) or which is cited to establish the publication date of another citation or other special reason (as specified)		
*O* document referring to an oral disclosure, use, exhibition or other means		
*P* document published prior to the international filing date but later than the priority date claimed		
*T* later document published after the international filing date or priority date and not in conflict with the application but cited to understand the principle or theory underlying the invention		
*X* document of particular relevance; the claimed invention cannot be considered novel or cannot be considered to involve an inventive step when the document is taken alone		
*Y* document of particular relevance; the claimed invention cannot be considered to involve an inventive step when the document is combined with one or more other such documents, such combination being obvious to a person skilled in the art.		
*&* document member of the same patent family		
Date of the actual completion of the international search	Date of mailing of the international search report	
11 December 2003	30/12/2003	
Name and mailing address of the ISA European Patent Office, P.B. 5818 Patentlaan 2 NL - 2280 HV Rijswijk Tel. (+31-70) 340-2040, Tx. 31 651 epo nl, Fax: (+31-70) 340-3016	Authorized officer  Daffner, M	

## INTERNATIONAL SEARCH REPORT

Internati  
Application No  
PCT/US 03/27217

## C.(Continuation) DOCUMENTS CONSIDERED TO BE RELEVANT

Category *	Citation of document, with indication, where appropriate, of the relevant passages	Relevant to claim No.
Y	EP 0 492 417 A (MATSUSHITA ELECTRIC IND CO LTD) 1 July 1992 (1992-07-01) page 5, line 53 - line 56 -----	1-3
Y	US 6 305 809 B1 (ZADRO ZLATKO) 23 October 2001 (2001-10-23) the whole document -----	5

# INTERNATIONAL SEARCH REPORT

Information on patent family members

International application No  
PCT/US 03/27217

Patent document cited in search report	A	Publication date	Patent family member(s)	Publication date
US 4481962	A	13-11-1984	NONE	
US 5230444	A	27-07-1993	NONE	
US 4248398	A	03-02-1981	NONE	
JP 09056549	A	04-03-1997	AU 718733 B2	20-04-2000
			AU 5014096 A	08-10-1996
			BR 9607868 A	30-06-1998
			CA 2215925 A1	26-09-1996
			CN 1184498 A ,B	10-06-1998
			DE 19681289 T0	16-04-1998
			DE 29623901 U1	06-07-2000
			EP 1304366 A1	23-04-2003
			EP 0816466 A1	07-01-1998
			JP 10146251 A	02-06-1998
			WO 9629375 A1	26-09-1996
			JP 9059045 A	04-03-1997
			JP 3127827 B2	29-01-2001
			JP 9057911 A	04-03-1997
			JP 9060443 A	04-03-1997
			JP 9059041 A	04-03-1997
			JP 9056742 A	04-03-1997
			JP 2943768 B2	30-08-1999
			JP 10156999 A	16-06-1998
			JP 9056535 A	04-03-1997
			JP 9056550 A	04-03-1997
			JP 9059042 A	04-03-1997
			JP 11070613 A	16-03-1999
			JP 11153701 A	08-06-1999
			JP 2865065 B2	08-03-1999
			JP 9057912 A	04-03-1997
			JP 2000075114 A	14-03-2000
			JP 2756474 B2	25-05-1998
			JP 2001026070 A	30-01-2001
			JP 2001145974 A	29-05-2001
			JP 3334709 B2	15-10-2002
			JP 2001152051 A	05-06-2001
			JP 3334710 B2	15-10-2002
			JP 2001150586 A	05-06-2001
			JP 2002355917 A	10-12-2002
			JP 2003291243 A	14-10-2003
			US 2002016250 A1	07-02-2002
			US 6013372 A	11-01-2000
EP 0492417	A	01-07-1992	DE 69123228 D1	02-01-1997
			DE 69123228 T2	13-03-1997
			EP 0492417 A2	01-07-1992
			JP 3187891 B2	16-07-2001
			JP 5031356 A	09-02-1993
			US 5143750 A	01-09-1992
US 6305809	B1	23-10-2001	NONE	