

(19) (KR)  
(12) (A)

(51) 。 Int. Cl.7

B63H 5/08

B63H 23/34

B63B 1/08

(11)

(43)

10-2004-0106477

2004 12 17

(21) 10-2004-7017835

(22) 2004 11 05

2004 11 05

(86) PCT/NO2003/000149

(87)

WO 2003/095302

(86) 2003 05 07

(87)

2003 11 20

(30) 200222220

2002 05 08

(NO)

(71)

, 1325 , . 15

(72)

, , 1390 가 32

, , -1349 28

(74)

:

(54)

(3), (2) (1) , (2)  
(6) 가 (4) (5) (7) 가 .  
(4) (6) ( ) , (2) (4) 가 .  
(5) (3) 가 , (6) (4) ( )  
, (7) (4) 가 (3) (7) 가 .

가 , b) , d) , e) 가 가 a) , c) (docking) (running a ground) 가 (skeg) 가 (bulge) 가 가 . U , 가 가 4 493 660 가 4 538 537 가 가 2 (drag) 1 (center line) (baseline) 가 ( ) 가 ( ) 3 ( ) 0 ( )가 0 10 , ( ) 1 5 , 2

( )가 , (waterline) 가 .  
 , , , 가  
 ( ) 가 ,  
 ( ) ( ) .  
 가 ( )

1 ,  
 2 1 ,  
 3 1 ,  
 4 1 2 ,  
 5 1 2 ,  
 6 1 2 ,  
 7 1 2 ,  
 8 1 2 ,  
 9 1 2 .

1 2 (1) (2) (3), (4)  
 (4) (5) (5) (4) ( )  
 4) . 1 (3) (1) (5) (2) (6) ,  
 2 (7) 가 (8)가  
 , (8)가  
 0 10 1 (4) (6) 1 ( ) 가  
 가 ( ) (4)가  
 ( )가 (8) (4) (3) (3)  
 (8) (8) (8)가 (3) (1) (3)  
 (6) (4) (4) (4)

(1) 가 (4) (4) ( )가 (1)  
(4)가 (6)  
( )  
(4) ( ) 1 5 (4) ( ) 1 3 (8) 2  
(9) (6) (8) (9) ( )  
4)가 (8) (4) (8) (8) (8)  
(8) ( ) (8) (8) (9) (4) (8)  
(8) (10) (10) 가 (1)  
(negative direction)  
(9) (8) (4)가  
가 3 가 (8)  
3 4 9 (8) (8) (5) (4) 3  
(5)가 (8) (8) (3)  
4 8 (5) (4) (8) (4) 5 (3)  
가 6 (8) 가 7 (8)  
(3) (7) (3) (1) (8) (8) ( )  
8) (2) 8 (2) (8)  
9 (8) (8) 4 538 537  
( ) 가 ( )  
가 가 1 ( ) 2  
1 (twin keels)'

(57)

1.

(2) (1) ,

(3), (4) (5) , (2)

(2) (6) 가 ,

(7) 가 ,

(4) 가 (4) (5) (6) ( ) , (6)

(3) 가 ,

(4) 가 (4) (7) ( ) , (7)

(3) 가 ,

.

2.

1 ,

( ) 1 10 ,가 1 3 ,

.

3.

1 2 ,

( ) 1 5 ,가 1 3 ,

.

4.

1 3 ,

(4) (8) ,

.

5.

1 4 ,

(4) (8) (8) (9)

,

.

6.

1 5 ,

(8) (5) (2)

(8) ,

.

7.

1 6 ,

(8)

(4)

,

8.

1 7

,

(8)

,

9.

1 8

,

(4)

(3)

(8)

,

(8)

10.

1 9

,

(4)

(5)

가

(4)가

11.

1 10

,

(6)

(7)

,

가

(

4)가

,



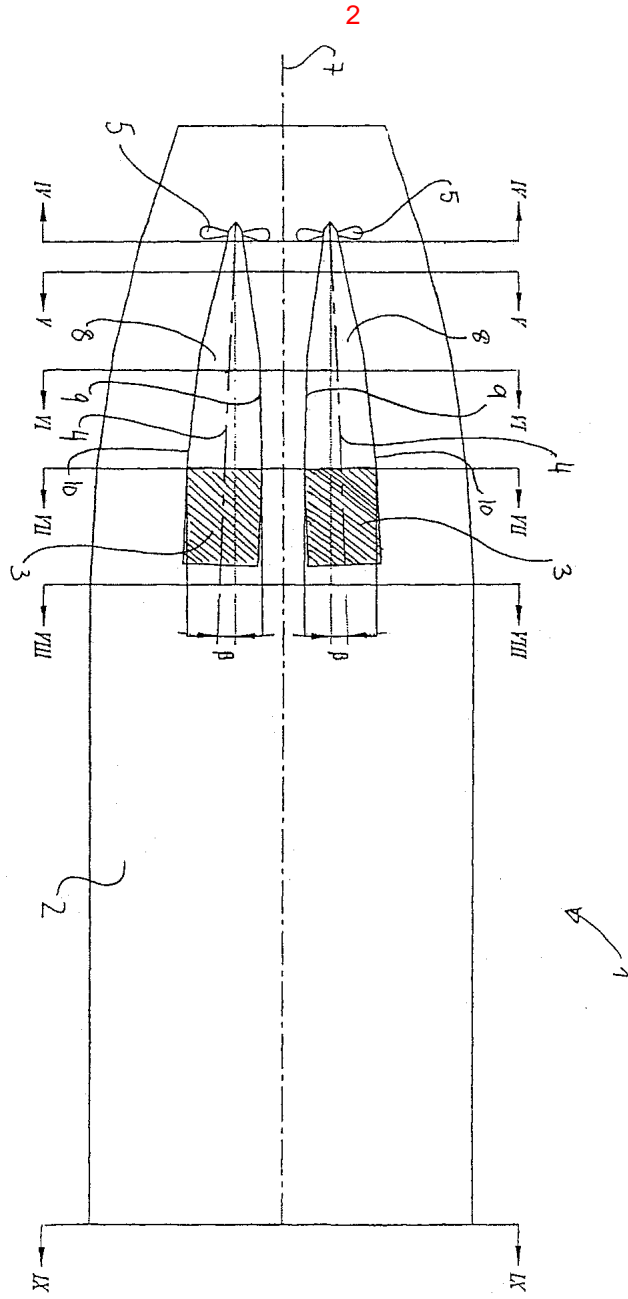

3

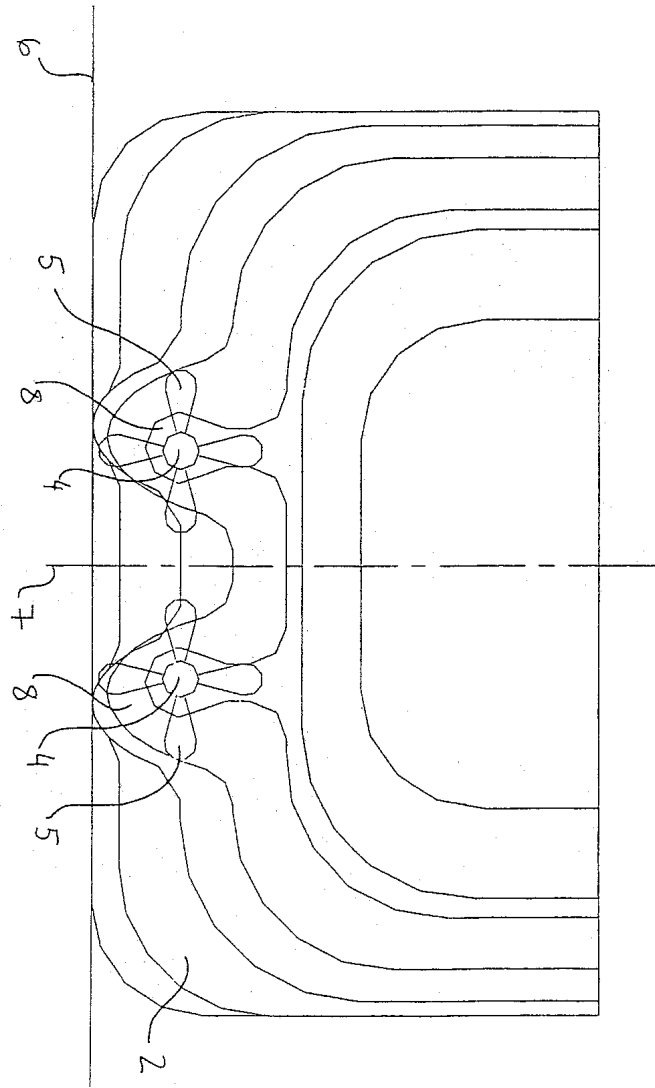

4

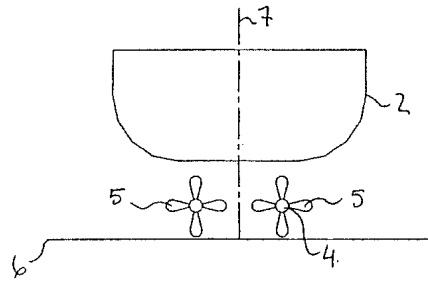

5

