



US00RE37369B1

(19) **United States**
(12) **Reissued Patent**
Hudgens et al.

(10) **Patent Number: US RE37,369 E**
(45) **Date of Reissued Patent: Sep. 18, 2001**

- (54) **SLOW RELEASE COOLANT FILTER**
- (75) Inventors: **R. Douglas Hudgens; Charles L. Matheson**, both of Cookeville, TN (US)
- (73) Assignee: **Fleetguard, Inc.**, Nashville, TN (US)
- (21) Appl. No.: **09/389,618**
- (22) Filed: **Sep. 2, 1999**

0 273 720 A3 7/1988 (EP) .
0 770 416 A1 5/1997 (EP) .

OTHER PUBLICATIONS

Truhan, J.J. and Hudgens, R. Douglas "An Evaluation of the Nalco Need-Release Coolant Filter" Report for internal use at Fleetguard, date unknown.

Mitchell, Wayne A. and Hudgens, R. Douglas "Development of an Extended-Service Coolant Filter", Engine Coolant Testing, Fourth Volume, ASTM STP 1335, R.E. Beal, editor, American Society for Testing of Materials, 1999, pp. 409-425.

Primary Examiner—Peter A. Hruskoci
(74) *Attorney, Agent, or Firm*—Woodard, Emhardt, Naughton Moriarty & McNett

Related U.S. Patent Documents

Reissue of:

- (64) Patent No.: **5,662,799**
- Issued: **Sep. 2, 1997**
- Appl. No.: **08/667,673**
- Filed: **Jun. 21, 1996**

- (51) **Int. Cl.⁷ B01D 27/04**
- (52) **U.S. Cl. 210/192; 165/134.1; 210/206; 210/209; 422/264; 422/278**
- (58) **Field of Search 165/119, 134.1; 210/192, 205, 206, 209, 443, 444; 422/261, 263, 264, 274, 277, 278, 283**

(57) **ABSTRACT**

A coolant filter for use in filtering a coolant solution which flows through the coolant filter includes a filter housing assembly which is made up of an outer housing which is crimped to a nutplate which defines an internally threaded flow outlet. A generally cylindrical filter element is positioned inside of the filter housing assembly and a first endplate is bonded to the end of the filter element which is adjacent to the nutplate. An endplate member is provided for attachment to the opposite end of the filter element and is configured in such a way so as to define an interior chamber where supplemental coolant additive pellets are stored. A closing plate is applied across the open end of the interior chamber so as to create an enclosed chamber for the supplemental coolant additive pellets. A slow release mechanism is provided for controlling the rate of release of the supplemental coolant additive from the enclosed chamber into the coolant solution. In one embodiment of the present invention, the slow release mechanism includes a diffusion tube which defines a diffusion orifice. In another embodiment of the present invention, the slow release mechanism includes a semipermeable (or osmotic) membrane wafer. In both instances, the slow release mechanism is positioned between the source of supplemental coolant additive and the flow outlet in the nutplate.

(56) **References Cited**

U.S. PATENT DOCUMENTS

2,995,253	8/1961	Belgarde et al.	210/323
3,369,666	2/1968	Hultgren et al.	210/130
3,645,402	2/1972	Alexander et al.	210/266
3,776,384	12/1973	Offer	210/209
3,897,335	7/1975	Brandt	210/71
4,075,098	2/1978	Paul et al.	210/168
4,357,236	11/1982	Krueger	210/167
4,366,057	12/1982	Bridges et al.	210/437
4,444,247	4/1984	Franck et al.	165/119
4,452,697	6/1984	Conrad	210/172
4,717,495	1/1988	Hercamp et al.	252/75
4,756,844 *	7/1988	Walles et al.	252/95
4,782,891	11/1988	Cheadle et al.	165/134.1

(List continued on next page.)

FOREIGN PATENT DOCUMENTS

553819 3/1958 (CA) .

37 Claims, 2 Drawing Sheets

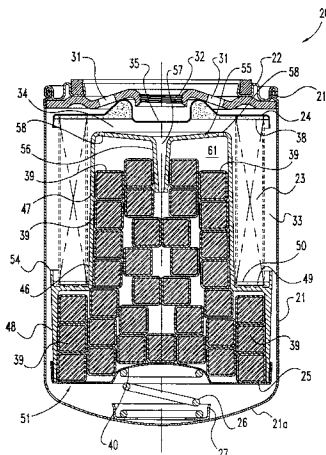

U.S. PATENT DOCUMENTS

			5,209,842	5/1993	Moor	210/168
4,842,731	6/1989	Dobrez et al.	5,258,118	11/1993	Gouritin et al.	210/206
4,885,141	12/1989	Gray et al.	5,350,506	9/1994	Dombek et al.	210/136
4,975,284	12/1990	Stead et al.	5,378,355	1/1995	Winkler	210/136
5,009,848	4/1991	Secretarski et al.	5,395,518	3/1995	Gulsvig	210/132
5,024,268	6/1991	Cheadle et al.	5,435,346	7/1995	Tregidgo et al.	137/154.5
5,050,549	9/1991	Sturmon	5,741,433	* 4/1998	Mitchell et al.	252/74
5,094,745	3/1992	Reynolds				
5,114,575	5/1992	Yano et al.				

* cited by examiner

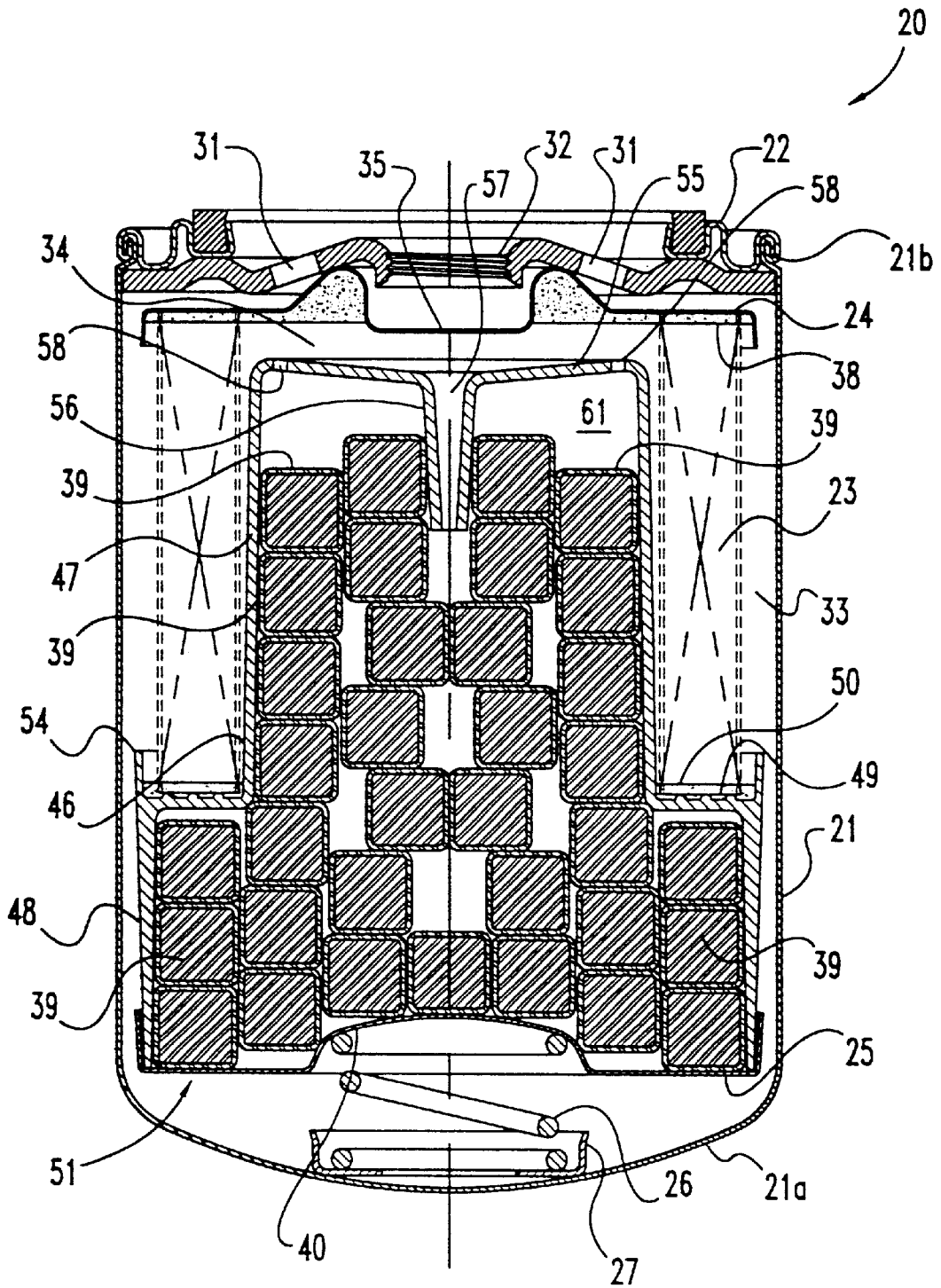

Fig. 1

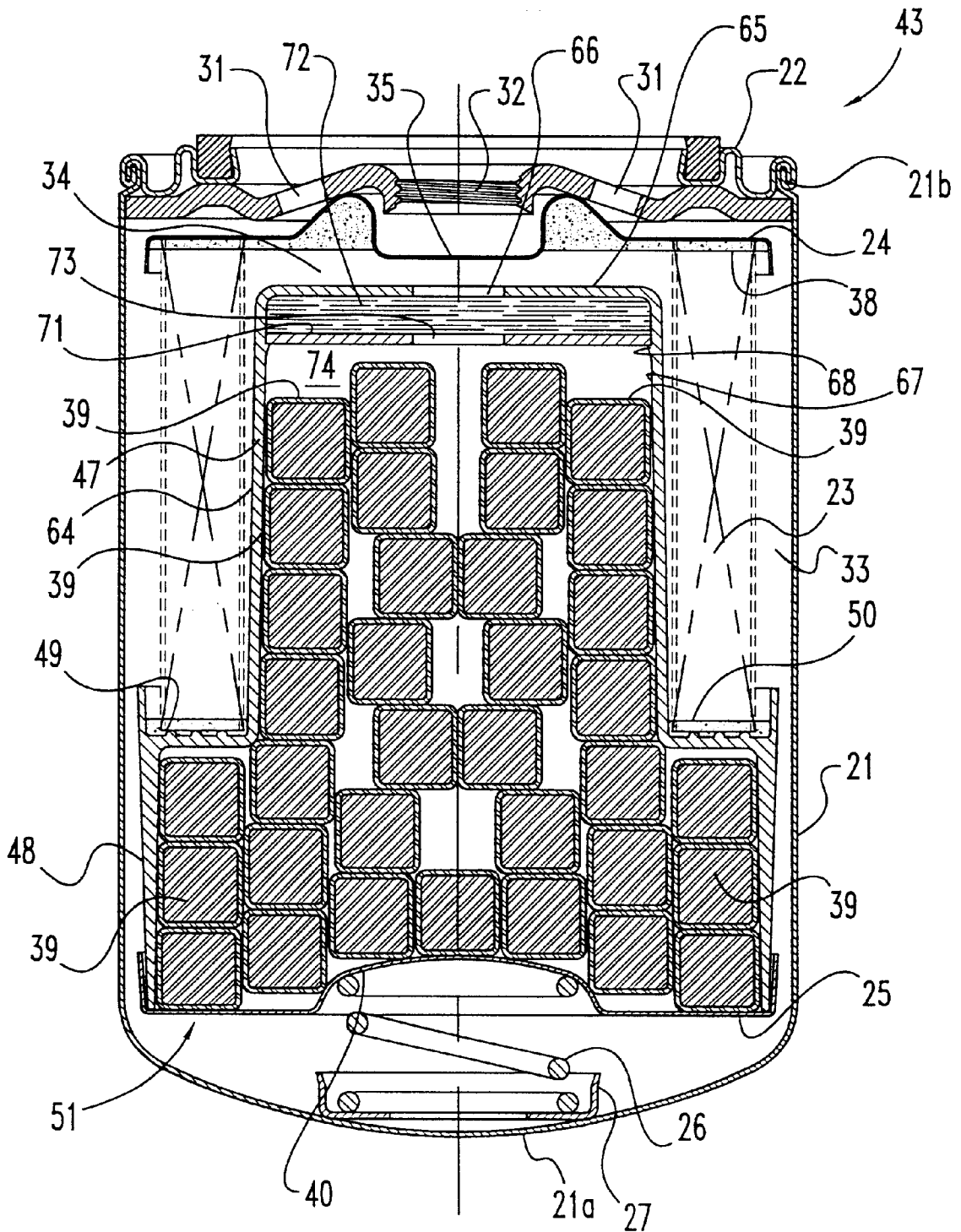

Fig. 2

SLOW RELEASE COOLANT FILTER

Matter enclosed in heavy brackets [] appears in the original patent but forms no part of this reissue specification; matter printed in italics indicates the additions made by reissue.

BACKGROUND OF THE INVENTION

The present invention relates generally to the design of coolant filters which are used in the operation of motor vehicles, such as motor vehicles including a diesel engine. More specifically the present invention relates to the design of a coolant filter with a chemical additive disposed within the filter which is released into the circulating coolant. The chemical additive is referred to as a supplemental coolant additive or SCA and is used to maintain the desired amount of corrosion inhibitors in the coolant during engine operation.

The typical approach in the past was to change the coolant filter at the oil drain interval. This would normally be a two-month interval involving a mileage interval of between 15,000 and 20,000 miles. Under these conditions, a moderate amount of SCA could be introduced into the system and it would be able to maintain the desired level of corrosion inhibitors in the coolant. As the SCA is depleted and the coolant concentration of inhibitors decreases, it is likely time for a filter change and a new SCA charge is then available to be delivered to the circulating coolant when the new filter is installed.

Recently there has been an interest in dramatically extending the coolant service interval from the typical two months interval to a once-a-year interval. This in turn increases the interval mileage from 15,000–20,000 miles up to approximately 120,000 miles, or more. A coolant filter which is designed to be changed once a year contains a relatively large amount of SCA. For the most part, filters of conventional design add the SCA into the coolant during the first few hundred miles of operation. This fairly rapid addition (dissolving) of the SCA into the coolant is directly related to the creation of certain undesirable "side effects". These referenced side effects can create certain problems for the corresponding engine and should be avoided if possible.

One side effect to be avoided is coolant additive precipitation which in turn can cause water pump leakage. Another side effect is a less uniform level of liner pitting protection. By means of the present invention which involves a slow release mechanism for the SCA, the SCA is able to be added to the coolant slowly, over at least the first 25,000 miles of vehicle operation rather than all during the first few hundred miles of vehicle operation. The slow release of SCA helps to avoid coolant additive precipitation and in turn helps to avoid water pump leakage. The present invention also enables a more uniform level of liner pitting protection to be maintained.

Coolant filters of the type incorporating the present invention are relatively large and would contain approximately ½ pound of SCA as a fresh charge with a new filter. With earlier extended-interval filters, this ½ pound of SCA would all be introduced into the coolant in two to three hours of vehicle operation. When this much SCA hits the system all at once as a slug, it is slow to absorb because it is more than what the coolant can handle. As a result, the SCA is likely to come out of solution as a precipitate and collect as a solid. What can result from this are precipitate deposits on the water pump face seals. Since these face seals ride on each other at approximately 1800 RPM, a fairly warm environ-

ment is created during vehicle operation which can actually bake the chemical solids of the precipitated SCA onto the facing surfaces of the face seals. The build up of solids on the facing surfaces will cause leakage to occur which is an undesirable side effect of dumping the SCA into the coolant too rapidly.

One situation which complicates and exacerbates this particular side effect involves the specific chemical additives which are used in the SCA composition. These specific chemical additives include silicates and MBT. Since these chemical additives are not highly soluble, nor as soluble as other potential SCA additives which may have been previously used, there is an even greater tendency for these additives to either not go into solution or to precipitate out of solution. Thus, while the "slug" concentration which is being dumped into the coolant in such a short time is likely to precipitate out based solely on concentration, a less soluble additive contributes to the formation of a precipitate.

With regard to the side effect that relates to liner pitting protection, it should be understood that liner "pitting" is a special type of corrosion that results when the liners which are bathed in coolant vibrate. Since piston movement is not perfectly vertical, there is a slight rocking action or slap which creates the liner vibration. Vapor bubbles are created as the coolant is pulled away from the liner. These vapor bubbles implode and a type of shock wave hits the surface of the liner at points where vibration is the greatest. The problem with pitting is that if it continues, it can perforate the liner and admit coolant into the crankcase.

The SCA is helpful to reduce liner pitting by passivating the liner surface. The nitrites in the SCA form a tough oxide coating on the surface of the liner and if enough nitrite is present, pitting can be virtually eliminated. The preferred approach for creating and maintaining the tough oxide coating is to slowly release the SCA into the coolant over two to three months (approximately 25,000 miles). With the prior approach of rapidly dumping the SCA into the coolant, there will be a greater loss of SCA due to system leakage and thus less of the chemical is available for creating the tough oxide layer.

System leakage is a fairly common occurrence. Due to a variety of reasons which include loose hoses and system interface losses, the coolant system may lose between 1 and 2 gallons of coolant solution per month. If the SCA is added into the coolant rapidly, then the SCA unit volume concentration is greater than with a slow release. When the 1 to 2 gallons of coolant solution are lost, the amount of SCA which is lost is substantial. As a consequence, the SCA which is lost is never able to perform its intended function of passivating the liner. With a slow release of SCA, the loss due to leakage is more gradual and a majority of the SCA remains available for a longer period of time.

The design challenge which is addressed by the present invention is how to slowly release the SCA into the coolant. The present invention solves this design challenge in several ways, each of which is believed to provide a novel and unobvious solution.

Over the years a number of coolant filters have been designed, some of which incorporate a supplemental coolant additive, and the following listed patents are believed to provide a representative sampling of these earlier designs:

PATENT NO.	PATENTEE	ISSUE DATE
5,435,346	Tregidgo et al	Jul. 25, 1995
5,395,518	Gulsvig	Mar. 7, 1995
3,897,335	Brandt	Jul. 29, 1975
3,369,666	Hultgren et al.	Feb. 20, 1968
5,094,745	Reynolds	Mar. 10, 1992
4,366,057	Bridges et al.	Dec. 28, 1982
4,452,697	Conrad	Jun. 5, 1984
4,782,891	Cheadle et al.	Nov. 8, 1988
5,024,268	Cheadle et al.	Jun. 13, 1981
5,114,575	Yano et al	May 19, 1992
5,209,842	Moor	May 11, 1993

In addition, the Penray Company of Wheeling, Ill. has offered for sale a "Need Release" filter which is intended to be an extended service interval coolant filter. With certain technical audiences this filter has been described as having a "delayed release" feature. The "Need Release" filter was originally offered by Nalco Chemical Company of Naperville, Ill. It is believed that the Nalco Chemical business has been acquired by the Penray Company. The "Need Release" filter includes a release mechanism which is based on magnesium corrosion. The filter has three large SCA pellets which are separated by magnesium plates all of which are housed in a copper sleeve or tube. Copper is used in order to establish a strong galvanic couple with the magnesium which promotes corrosion of the magnesium.

Other than operating on a different release principle and other than being structurally different from the claimed invention, the "Need Release" filter includes several drawbacks which are not present with the present invention. For example, the magnesium can dissolve into the coolant where it can cause additive precipitation and deposits in the cooling system. Another concern is that lube oil can on occasion leak into the coolant which will result in an oily film on the magnesium plate. This prevents the plate from corroding and releasing the SCA. The "Need Release" filter must be used with the proper HD type antifreeze and thus the product will not work properly when the coolant is only water. A further drawback is that the magnesium plate can build up a scale which stops corrosion which in turn prevents SCA release.

Although a variety of coolant filter designs have in the past been offered for sale and while extended service interval coolant filters are now receiving more attention, the present invention is novel and unobvious. The present invention provides a desirable solution to the design task which is directed to the avoidance of the undesirable side effects which have been described.

SUMMARY OF THE INVENTION

A coolant filter for use in filtering a coolant solution which flows through the coolant filter according to one embodiment of the present invention comprises a filter housing assembly defining a flow outlet, a filter element positioned inside of the filter housing assembly, an endplate member which is configured with an interior chamber, a source of a supplemental coolant additive which is positioned within the interior chamber, and a slow release arrangement which is disposed between the source of supplemental coolant additive and the flow outlet for controlling the rate of release of the supplemental coolant additive from the interior chamber into the coolant solution.

One object of the present invention is to provide an improved coolant filter.

Related objects and advantages of the present invention will be apparent from the following description.

BRIEF DESCRIPTION OF THE DRAWINGS

FIG. 1 is a front elevational view in full section of a coolant filter according to a typical embodiment of the present invention.

FIG. 2 is a front elevational view in full section of a coolant filter according to another typical embodiment of the present invention.

DESCRIPTION OF THE PREFERRED EMBODIMENT

For the purposes of promoting an understanding of the principles of the invention, reference will now be made to the embodiment illustrated in the drawings and specific language will be used to describe the same. It will nevertheless be understood that no limitation of the scope of the invention is thereby intended, such alterations and further modifications in the illustrated device, and such further applications of the principles of the invention as illustrated therein being contemplated as would normally occur to one skilled in the art to which the invention relates.

Referring to FIG. 1 there is illustrated a coolant filter 20 according to one embodiment of the present invention. The illustrated construction of filter 20 is intended to include the basic components and construction which would be typical of such filters, with the exception of the supplemental coolant additive (SCA) and the slow release mechanism associated with the SCA. The basic components of filter 20 include the annular outer housing 21, nutplate 22, substantially cylindrical filter element 23, outlet endplate 24, base endplate 25, support spring 26, and spring protector 27.

The outer housing 21 has a closed base end 21a and an open outlet end 21b which is crimped to the outer edge periphery of nutplate 22. The crimped combination creates a filter housing assembly. Nutplate 22 provides the inlet flow openings 31 for coolant to enter the filter 20 and the internally threaded outlet aperture 32 which is defined by nutplate 22 provides the flow exit for the filtered coolant. The outlet endplate 24 is shaped and arranged relative to the inside surface of the nutplate so as to direct the incoming flow of coolant into annular space 33 and from there through the filter element 23 in a radially inward direction into interior space 34. Interior space 34 leads through the flow control orifice 35 in the outlet endplate 24 to outlet aperture 32. Outlet endplate 24 is bonded to the adjacent end 38 of filter element 23 by a layer of adhesive. This layer of adhesive also seals off the end of the filter element in order to prevent any undesirable bypass or short circuit flow of coolant.

Base endplate 25 provides a support and seat for the filter element 23 as well as for the components associated with the present invention, including the SCA which is provided in the form of a plurality of coated tablets or pellets 39. The illustrated pellets 39 are roughly cubic in form and are completely coated in order to retard the release of SCA into the coolant. Spring 26 is seated inside of spring protector 27 and pushes up against the receiving depression 40 which is formed in the center of base endplate 25.

The foregoing description of the basic filter components and construction of coolant filter 20 provided with regard to the FIG. 1 illustration is applicable to coolant filter 43 which is illustrated in FIG. 2. Accordingly, the same reference numbers are used for the same components. The differences between filters 20 and 43 are embodied in the structures which house the plurality of coated pellets 39.

Referring to FIG. 1, coolant filter 20 includes a molded, unitary endplate 46 which is configured with an inner,

substantially cylindrical portion 47 and an outer, substantially cylindrical portion 48. The unitary endplate 46 defines an interior chamber which is filled with coated pellets 39 and then enclosed by means of base endplate 25. Annular shelf 49 provides a substantially flat surface for the receipt and support of filter element 23. A layer of adhesive applied between the adjacent end 50 of the filter element 23 and shelf 49 serves the dual purpose of bonding the filter element in place and sealing end 50 of the filter element. The outside diameter size of portion 47 is slightly smaller than the inside diameter size of filter element 23. Base endplate 25 fits across the open end 51 of endplate 46 and up around the side so as to close off the open end 51. A relatively short cylindrical wall 54 which is substantially concentric to inner portion 47 creates an annular channel to hold in the adhesive which is applied to shelf 49.

Inner portion 47 includes an upper wall 55 which is adjacent the outlet end of the housing and is formed with an inwardly, axially protruding and centered, tapered diffusion tube 56. Diffusion tube 56 defines a tapered diffusion passage or orifice 57 which extends therethrough and establishes a passageway of communication between the interior chamber of endplate 46 and interior space 34. A plurality of air vents 58 are disposed in upper wall 55. There is a slight conical draft to upper wall 55 leading from the air vents inwardly to diffusion orifice 57. Upper wall 55 is positioned between the source of SCA (pellets 39) and outlet aperture 32 and the point of exit from diffusion orifice 57 into interior space 34 is coincident with the conical portion of upper wall 55. This arrangement necessitates that any SCA which is released from within the interior chamber into the coolant must flow through the diffusion tube 56.

As is illustrated, the unitary endplate 46 as seated within and on base endplate 25 creates an enclosed chamber 61 with the only openings into the enclosed chamber being the diffusion orifice 57 and air vents 58. The enclosed chamber 61 is filled with coated SCA pellets 39 which provide a timed release of a supplemental coolant additive (SCA) which gradually goes into the coolant.

Each coated pellet 39 includes an outer coating which encases a selected SCA composition. The outer coating may be hard or soft and while each style has its own mechanism for exposing the encased SCA to the coolant, either style is suitable for use with the present invention. The typical and preferred coatings are polyvinylidene chloride (PVDC) and polyvinyl acetate (PVA). The PVDC material is a hard coating which releases when coolant gradually soaks through the coating. The coolant causes the SCA inside of the coating to swell and eventually this causes the coated pellet to crack open. This then exposes the SCA inside to the coolant. The PVA material is a soft coating which releases by a different mechanism. While coolant also penetrates the coating, the coating is soft and pliable and does not crack open. Instead the coolant diffuses through the coating, dissolves some of the SCA and then escapes back out of the coated pellet. While both the PVDC and PVA coating materials are insoluble coatings, the present invention is compatible with soluble coating materials. Insoluble coatings are preferred because there are no concerns about corrosion or deposits. With a soluble coating, there could be corrosion or deposit problems as the soluble coating builds up in the coolant. The SCA material which is encased in each of the coated pellets is preferably a modified version of DCA-4 which is a phosphate/molybdate/nitrite type SCA recommended by Cummins Engine Company, Inc. of Columbus, Ind. This SCA material is described in U.S. Pat. No. 4,717,495 which issued Jan. 5, 1988 to Hercamp, et al. The U.S. Pat. No. 4,717,495 patent is hereby incorporated by reference.

As the coolant flows through the coolant filter 20, a portion of the coolant fills the enclosed chamber 61 and begins the process of breaking through the outer coating of the pellets 39. As the SCA is exposed pellet-by-pellet and gradually goes into solution, it will have a higher concentration inside of chamber 61 than outside of chamber 61 in interior space 34. Accordingly, there will be a lower concentration of the SCA material in the flowing coolant and there is a natural tendency of different concentration levels to flow in an effort to achieve equilibrium. This causes the higher concentration of SCA in solution with the coolant to gradually flow out of the enclosed chamber 61 by way of diffusion orifice 57. By including the diffusion tube 56 and the defined diffusion orifice 57 as part of upper wall 55, there is a restricted opening for the migration of the higher concentration solution out of the enclosed chamber 61. The air vents 58 allow any air bubbles to escape without having to flow through the diffusion orifice 57.

If the diffusion orifice 57 was made larger or if upper wall 55 was removed from the unitary endplate 46, the higher concentration mixture would enter the flow of coolant (lower concentration) at a faster rate, thereby speeding the rate at which all of the SCA is introduced into the coolant. In turn, this would reduce the time and mileage interval and could preclude this modified design from achieving the objective of a slow release of the SCA over the first 25,000 miles of vehicle operation. Although the initial 25,000 miles is the target objective, the longer the period of release of the SCA into the coolant, the less risk there will be of encountering any of the undesirable side effects.

One alternative to the design of the FIG. 1 coolant filter is to replace the plurality of coated pellets 39 with a fewer number of much larger pellets or tablets. By reducing the total surface area of the coating for a particular mass of SCA and by reducing the total surface area of the SCA, there is a slower rate of dissolving of the SCA into the coolant. While this slower dissolving rate is preferable over a faster rate, the preferred embodiment includes the use of mechanical means to slow down the process, such as configuring endplate 46 with the diffusion tube 56 and diffusion orifice 57.

By means of the diffusion tube 56 and diffusion orifice 57, a flow-limiting orifice is provided which limits the engine coolant contact with the SCA and thus a slower rate and a longer mileage interval for the SCA to dissolve into the engine coolant. As the SCA dissolves, there is a higher concentration of SCA in the SCA and coolant mixture inside of the enclosed chamber 61. The diffusion orifice 57 then limits the rate at which this higher concentration solution diffuses into the main flow stream of coolant which has a lower concentration of SCA.

Referring now to FIG. 2, an alternative embodiment of the present invention is illustrated. As has been previously mentioned, the basic filter components of filter 43 are the same as those of filter 20 and accordingly the same reference numbers have been used. Located within filter 43 is a molded, unitary endplate 64 which for the most part is sized and shaped the same as endplate 46 with one important difference. The upper wall 55, diffusion tube 56, diffusion orifice 57, and air vents 58 have been replaced by a double wall structure which includes a semipermeable membrane wafer sandwiched therebetween. The remainder of endplate 64 is virtually identical to endplate 46 including the remainder of inner portion 47, outer portion 48, shelf 49, and open end 51. Accordingly, the same reference numbers have been used to identify the common components between the FIG. 1 coolant filter and the FIG. 2 coolant filter. Further, the

positioning of the FIG. 2 filter element 23 is the same as in FIG. 1 including the use of an adhesive to seal closed ends 38 and 50 and bond those ends to outlet endplate 24 and to shelf 49, respectively.

With regard to the differences between the FIG. 1 and FIG. 2 embodiments, the inner portion 47 includes a unitary upper wall 65 which defines centrally therein an orifice 66. The inside surface 67 of portion 47 is molded with a small annular lip 68 which serves as a retainer for circular plate 71. Plate 71 functions as a second wall in cooperation with upper wall 65 in order to hold in position therebetween a substantially cylindrical, diffusion or osmotic wafer 72. The preferred material for diffusion wafer 72 is microporous polypropylene. Plate 71 defines centrally therein an orifice 73 which is aligned with orifice 66. This combination permits the gradual flow of coolant into enclosed chamber 74 in order to act on pellets 39. Diffusion wafer 72 is positioned between the source of SCA (pellets 39) and the outlet aperture 32 necessitating that the release of SCA into the coolant must pass through wafer 72. By configuring diffusion wafer 72 from a semipermeable membrane material, the rate of flow through orifices 66 and 73 in either direction is restricted and slowed. While coolant only gradually seeps into chamber 74, any higher SCA concentration solution which is created in chamber 74 only gradually seeps out of chamber 74 into the primary flow path of the lower SCA concentration coolant. The use of a semipermeable membrane in the form of wafer 72 provides a slow release of SCA into the coolant flow stream and thereby enables the SCA to be released more gradually and over a longer time/mileage interval. The slow release of SCA into the coolant provides a coolant filter design which is able to avoid the undesirable side effects which have been discussed in connection with other earlier systems and other earlier filter designs.

While it would be possible to replace the coated pellets 39 with some other form of SCA in either the FIG. 1 coolant filter 20 or in the FIG. 2 coolant filter 43 designs, the use of the coated pellets 39 is preferred. The use of the smaller pellets allows a larger mass of SCA to be loaded into the enclosed chamber without any particular regard to the size or shape of the enclosed chamber 61/74. If a larger tablet or tablets were used, then the size and shape of the enclosed chamber would be a concern, at least if the available tablet sizes were limited.

According to the present invention a diffusion tube and diffusion orifice may be used to slow the release of SCA into the coolant. This mechanical arrangement may be used with a plurality of smaller SCA pellets or with larger SCA tablets or with some other form of SCA. In an alternate embodiment of the present invention, a semipermeable membrane wafer is sandwiched between an upper wall and a retaining plate and provides the slow release mechanism due to the composition of the wafer. This mechanical arrangement may be used with a plurality of smaller SCA pellets or with larger SCA tablets or with some other form of SCA.

Referring now to the illustrated embodiments of FIGS. 1 and 2, it will be seen that there is in fact a coolant filter cartridge which is created and present in both embodiments. While filters 20 and 43 are configured as disposable units, it would be possible to configure the outer housing and the nutplate as separable members allowing the filter cartridge to be removed and replaced. Accordingly, the referenced coolant filter cartridge includes the filter element 23, the outlet endplate 24, the base endplate 25, the source of coated SCA pellets 39, and a corresponding unitary endplate 46 or 64.

While the invention has been illustrated and described in detail in the drawings and foregoing description, the same is to be considered as illustrative and not restrictive in character, it being understood that only the preferred embodiment has been shown and described and that all changes and modifications that come within the spirit of the invention are desired to be protected.

What is claimed is:

1. A coolant filter for use in filtering a coolant solution which flows through the coolant filter and being designed for the release of a supplemental coolant additive into said coolant solution, said coolant filter comprising:

a filter housing assembly defining a flow outlet and flow inlet means;

a filter element positioned inside said filter housing assembly;

an endplate member which is configured with an interior chamber and having a first end wall, an opposite second end wall, a first substantially cylindrical wall portion disposed between said first and second end walls and having a first diameter, a second substantially cylindrical wall portion disposed between the first and second end walls and having a second diameter greater than the first diameter and a radially extending shelf therebetween to bear against the filter element, said endplate member in cooperation with said filter element [defining] defines an interior space [for receiving filtered coolant solution];

a source of supplemental coolant additive positioned within said interior chamber; and

slow release means disposed between said source of supplemental coolant additive and said flow outlet for permitting a portion of said [filtered] coolant solution [from said interior space to enter said interior chamber] to dissolve said supplemental coolant additive and for controlling the rate of release of said supplemental coolant additive [from said interior chamber into said filtered coolant solution in said interior space].

2. The coolant filter of claim 1 wherein said source of supplemental coolant additive includes a plurality of soluble supplemental coolant additive pellets.

3. The coolant filter of claim 2 wherein said plurality of soluble supplemental coolant additive pellets are coated with an outer coating consisting essentially of a polymeric material including a polyvinyl acetate material.

4. The coolant filter of claim 3 wherein said slow release means includes a diffusion tube defining a diffusion orifice.

5. The coolant filter of claim 4 wherein said diffusion tube and said diffusion orifice are tapered.

6. The coolant filter of claim 3 wherein said slow release means includes a semipermeable membrane wafer.

7. The coolant filter of claim 6 wherein said semipermeable membrane wafer is fabricated out of a microporous polypropylene material.

8. A coolant filter for use in filtering a coolant solution which flows through the coolant filter and being designed for the release of a supplemental coolant additive into said coolant solution, said coolant filter comprising:

a filter housing assembly defining a flow outlet and flow inlet means;

a filter element positioned inside said filter housing assembly;

an endplate member which is configured with an interior chamber, said endplate member in cooperation with said filter element defining an interior space for receiving filtered coolant solution;

- a source of supplemental coolant additive positioned within said interior chamber; and
- a diffusion tube comprising part of said endplate member and defining a diffusion orifice which is disposed between said source of supplemental coolant additive and said flow outlet for permitting a portion of said filtered coolant solution from said interior space to enter said interior chamber to dissolve said supplemental coolant additive and for controlling the rate of release of said supplemental coolant additive from said interior chamber into said filtered coolant solution in said interior space.
9. The coolant filter of claim 8 wherein said diffusion tube and said diffusion orifice are tapered.
10. The coolant filter of claim 9 wherein said source of supplemental coolant additive includes a plurality of soluble supplemental coolant additive pellets.
11. The coolant filter of claim 10 wherein said plurality of soluble supplemental coolant additive pellets are coated with a polyvinyl acetate material.
12. The coolant filter of claim 8 wherein said source of supplemental coolant additive includes a plurality of soluble supplemental coolant additive pellets.
13. The coolant filter of claim 12 wherein said plurality of soluble supplemental coolant additive pellets are coated with a polyvinyl acetate material.
14. A coolant filter for use in filtering a coolant solution which flows through the coolant filter and being designed for the release of a supplemental coolant additive into said coolant solution, said coolant filter comprising:
- a filter housing assembly defining a flow outlet and flow inlet means;
 - a filter element positioned inside said filter housing assembly;
 - an endplate member which is configured with an interior chamber, said endplate member in cooperation with said filter element defining an interior space for receiving filtered coolant solution;
 - a source of supplemental coolant additive positioned within said interior chamber; and
 - a semipermeable membrane wafer assembled to said endplate member and disposed between said source of supplemental coolant additive and said flow outlet for permitting a portion of said filtered coolant solution from said interior space to enter said interior chamber to dissolve said supplemental coolant additive and for controlling the rate of release of said supplemental coolant additive from said interior chamber into said filtered coolant solution in said interior space.
15. The coolant filter of claim 14 wherein said semipermeable membrane wafer is fabricated out of a microporous polypropylene material.
16. The coolant filter of claim 15 wherein said source of supplemental coolant additive includes a plurality of soluble supplemental coolant additive pellets.
17. The coolant filter of claim 16 wherein said plurality of soluble supplemental coolant additive pellets are coated with a polyvinyl acetate material.
18. The coolant filter of claim 14 wherein said source of supplemental coolant additive includes a plurality of soluble supplemental coolant additive pellets.
19. The coolant filter of claim 18 wherein said plurality of soluble supplemental coolant additive pellets are coated with a polyvinyl acetate material.
20. The coolant filter of claim 19 which further includes a retainer plate held in position by said endplate member and

- sandwiching said wafer between a portion of said endplate member and said retainer plate.
21. A coolant filter cartridge for installing into a filter housing assembly for the filtering of a coolant solution, said coolant filter cartridge being designed for the release of a supplemental coolant additive into said coolant solution, said coolant filter cartridge comprising:
- a filter element having a first end and opposite thereto a second end;
 - a first endplate bonded to the first end of said filter element;
 - a second endplate bonded to the second end of said filter element, said second endplate configured so as to define an interior chamber, said second endplate member in cooperation with said filter element defining an interior space for receiving filtered coolant solution;
 - a source of supplemental coolant additive positioned within said interior chamber;
 - a closing member assembled to said second endplate so as to enclose said interior chamber; and
 - slow release means disposed between said source of supplemental coolant additive and said flow outlet for permitting a portion of said filtered coolant solution from said interior space to enter said interior chamber to dissolve said supplemental coolant additive and for controlling the rate of release of said supplemental coolant additive from said interior chamber into said filtered coolant solution in said interior space.
22. The coolant filter cartridge of claim 21 wherein said source of supplemental coolant additive includes a plurality of soluble supplemental coolant additive pellets.
23. The coolant filter cartridge of claim 22 wherein said plurality of soluble supplemental coolant additive pellets are coated with a polyvinyl acetate material.
24. The coolant filter cartridge of claim 23 wherein said slow release means includes a diffusion tube defining a diffusion orifice.
25. The coolant filter cartridge of claim 24 wherein said diffusion tube and said diffusion orifice are tapered.
26. The coolant filter cartridge of claim 23 wherein said slow release means includes a semipermeable membrane wafer.
27. The coolant filter cartridge of claim 26 wherein said semipermeable membrane wafer is fabricated out of a microporous polypropylene material.
28. *The coolant filter of claim 1 comprising an outer coating consisting essentially of a polymeric material substantially encasing the supplemental coolant additive.*
29. *The coolant filter of claim 28 wherein said outer coating includes a material formed of polyvinyl acetate or polyvinylidene chloride.*
30. *A coolant filter for use in filtering a coolant solution which flows through the coolant filter and being designed for the release of a supplemental coolant additive into said coolant solution, said coolant filter comprising:*
- a filter housing assembly defining a flow outlet and flow inlet means;*
 - a filter element positioned inside said filter housing assembly;*
 - an endplate member which is configured with an interior chamber and having a first end wall, an opposite second end wall, a first substantially cylindrical wall portion disposed between said first and second end walls and having a first diameter, a second substantially cylindrical wall portion disposed between the first and second end walls and having a second diam-*

11

eter greater than the first diameter and a radially extending shelf therebetween to bear against the filter element, said endplate member in cooperation with said filter element defining an interior space;

a source of supplemental coolant additive positioned within said interior chamber said source of supplemental coolant additive including a supplemental coolant additive having an outer coating; and

slow release means for controlling the rate of release of said supplemental coolant additive.

31. The coolant filter of claim 30 wherein said slow release means includes a diffusion tube defining a diffusion orifice.

32. The coolant filter of claim 30 wherein said slow release means includes a semipermeable membrane wafer.

33. The coolant filter of claim 30 wherein said outer coating consists essentially of a polymeric material substantially encasing the supplemental coolant additive.

34. A coolant filter for use in filtering a coolant solution which flows through the coolant filter and being designed for the release of a supplemental coolant additive into said coolant solution, said coolant filter comprising:

12

a filter housing assembly defining a flow outlet and flow inlet means;

a filter element positioned inside said filter housing assembly;

an endplate member which is configured with an interior chamber, said endplate member in cooperation with said filter element defining an interior space;

a source of supplemental coolant additive positioned within said interior chamber, said supplemental coolant additive substantially encased within an outer coating consisting essentially of a polymeric material, wherein the outer coating retards release of the supplemental coolant additive.

35. The coolant filter of claim 1 wherein the first end wall includes a diffusion orifice.

36. The coolant filter of claim 34 wherein the endplate member comprises a diffusion orifice.

37. The coolant filter of claim 34 wherein the endplate member comprising a semipermeable membrane.

* * * * *