

J. H. HERRIFF.  
Car Coupling.

No. 201,669.

Patented March 26, 1878.

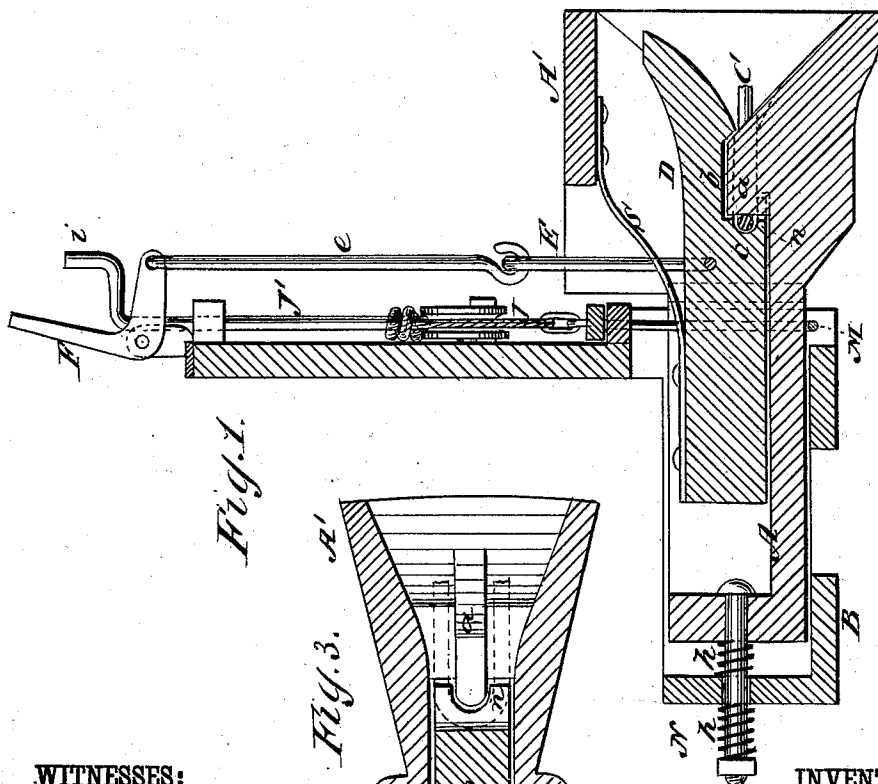
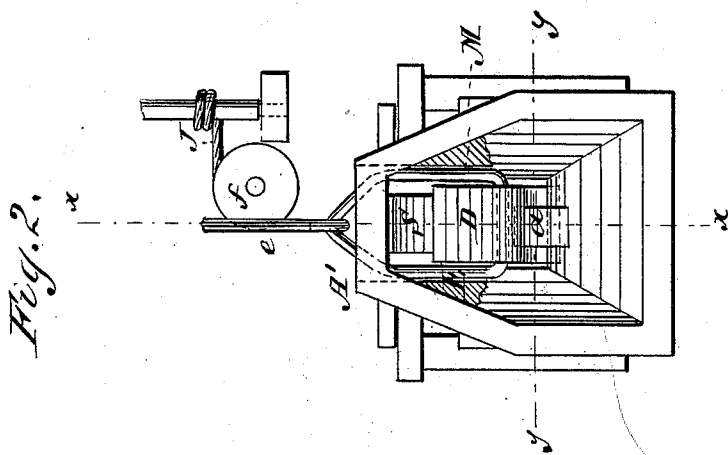

Fig. 1.

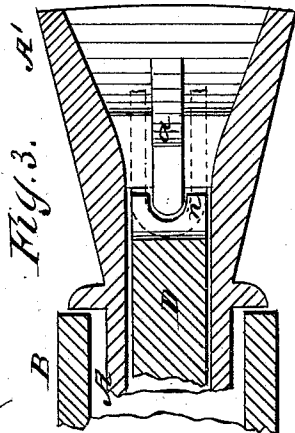

Fig. 3.

WITNESSES:

*E. Wolff*  
*J. H. Scarborough.*

INVENTOR:

*J. H. Herriff.*  
BY *Munn & Co.*

ATTORNEYS.

# UNITED STATES PATENT OFFICE.

JONAS H. HERRIFF, OF CITY BLUFF, MISSOURI.

## IMPROVEMENT IN CAR-COUPINGS.

Specification forming part of Letters Patent No. **201,669**, dated March 26, 1878; application filed October 31, 1877.

*To all whom it may concern:*

Be it known that I, JONAS H. HERRIFF, of City Bluff, in the county of Nodaway and State of Missouri, have invented a new and Improved Car-Coupling, of which the following is a specification:

The invention will first be described in connection with the drawings, and then pointed out in the claims.

In the annexed drawings, Figure 1 is a vertical section taken longitudinally through one end of a car having my improved coupling applied to it. Fig. 2 is a front view of the coupling. Fig. 3 is a section taken horizontally through the front end of the draw-bar on its coupling-hook, in the plane indicated by the dotted line *y y* on Fig. 2.

Similar letters of reference indicate corresponding parts.

The letter A designates the shank of a draw-bar, which is guided in a box, B, and constructed with an open outwardly-flaring head or mouth, A', that is angular in shape, and adapted to receive the link C and guide it to its place behind a central steel fin, *a*, that may be replaced when worn, rising from the floor of the draw-bar.

D designates a coupling-hook, the upper side of which is connected by a curved spring, S, to the roof of the flaring portion A' of the draw-bar. This coupling-hook is constructed with an upwardly-directed front end, in rear of which is a longitudinal groove, *b*, to receive the fin *a*, and a transverse groove, *c*, to receive the link C when one end of it falls behind the said fin.

The coupling-hook D has attached to it a bail, E, which, by means of a connecting-rod, *e*, and an angular lever, F, on the end of the car, will allow the front end of the coupling-hook to be raised.

During the act of raising the front end of the coupling-hook D to effect an uncoupling, the lip *n* beneath the transverse groove *c* will

lift the end of the link over the rear end of the fin *a*. When a coupling is effected, the fin *a* and grooved coupling-hook D will prevent a casual detachment of the link.

The rear end of the draw-bar A is connected to the box B or its equivalent by means of a loose bolt, *g*, which passes through a cross-beam, N, and is inclosed on opposite sides of this beam by means of springs *h h* of metal, india-rubber, or other elastic material. These springs prevent shocks in starting or stopping cars.

The draw-bar is suspended from a chain, J, by means of a stirrup, M, arranged between suitable guides, and allowed to receive free vertical movement. The chain J is passed over a grooved pulley, *f*, and around a vertical rod, J', which is free to turn in journal-boxes fixed to the end of the car. The brakeman can raise or lower the coupling end of the draw-bar by grasping the crank *i* on the upper end of the rod J' and turning this rod.

The support of the link on floor of draw-head is arranged to act as a fulcrum, so that, in case a car should fall from the track or through a bridge, it raises the end of the link which is fastened to the car which remains on the track against coupling-hook D, thereby lifting itself over the fin *a*, when the car will be free from the balance of the train.

Having thus described my invention, I claim as new and desire to secure by Letters Patent—

1. A hook, D, held by a spring, S, in draw-bar, in combination with bail E, rod *e*, and bent lever F, as and for the purpose set forth.

2. The draw-bar A, suspended by a stirrup, M, chain J passing over pulley, and rotary rod J', as and for the purpose specified.

JONAS HARTZELL HERRIFF.

Witnesses:

J. F. MONTGOMERY,  
J. W. JONES.