

R. J. WYLIE.  
Feed-Cutter.

No. 169,221.

Patented Oct. 26, 1875.

*Fig. 1.*

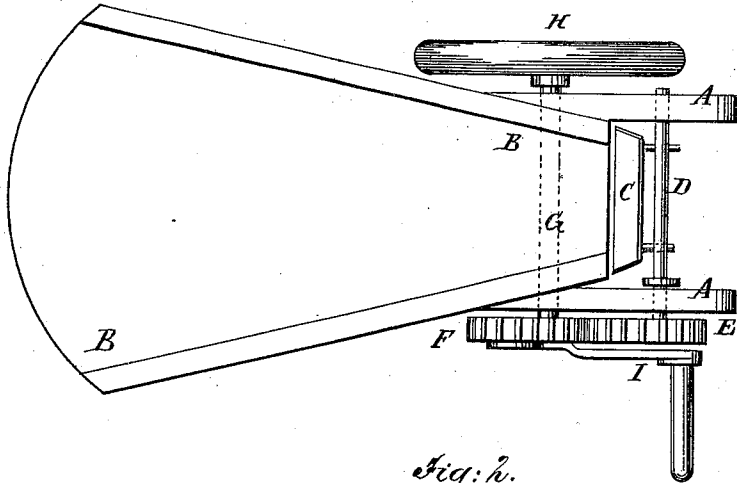

*Fig. 2.*

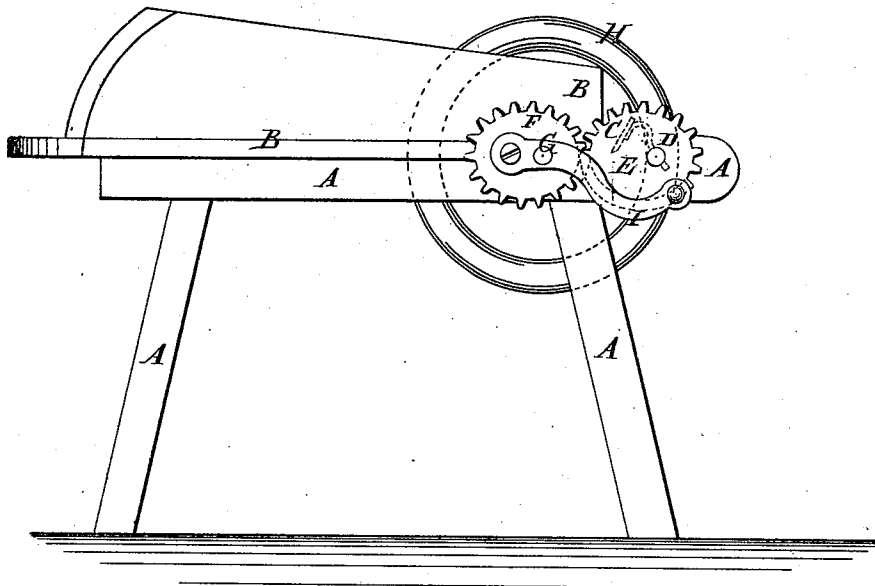

WITNESSES:

*Chas. Nida*  
*A. J. Terry*

INVENTOR:

*Robert J. Wylie*  
BY *Wm. L. Terry*  
ATTORNEYS.

# UNITED STATES PATENT OFFICE.

ROBERT J. WYLIE, OF MARISSA, ILLINOIS.

## IMPROVEMENT IN FEED-CUTTERS.

Specification forming part of Letters Patent No. **169,221**, dated October 26, 1875; application filed March 29, 1875.

*To all whom it may concern:*

Be it known that I, ROBERT J. WYLIE, of Marissa, in the county of St. Clair and State of Illinois, have invented a new and useful Improvement in Feed-Cutter, of which the following is a specification:

Figure 1 is a top view of my improved feed-cutter. Fig. 2 is a side view of the same.

Similar letters of reference indicate corresponding parts.

The object of this invention is to furnish an improved cutter for cutting straw, hay, &c., which shall be so constructed as to enable the knife to be operated with greater power while cutting, and which shall be simple in construction and convenient in use.

The invention consists in the combination, in a feed-cutter, of the two eccentric gear-wheels with each other, and with the shaft that carries the knife, the shaft that carries the fly-wheel, and the crank, as hereinafter fully described.

A represents the frame of the machine, and B the feed-box. C is the knife, which is attached to arms secured adjustably to the shaft D. The shaft D revolves in bearings in projecting bars of the frame A, or bars attached to the frame A. To one end of the shaft D is attached an eccentric gear-wheel, E, the

teeth of which mesh into the teeth of the eccentric gear-wheel F, attached to the end of the shaft G. The shaft G revolves in bearings in the frame A, and to its other end is attached a fly-wheel, H, to give steadiness of motion to the machine. With the gear-wheel F is rigidly connected the crank I, by which motion is given to the machine. The wheels E F are geared to each other, with the long radius of the one wheel opposite the short radius of the other, and the knife C is arranged toward the long radius of the wheel E, so that the power will be applied with the greatest advantage of leverage at the time the knife is cutting.

Having thus described my invention, I claim as new and desire to secure by Letters Patent—

The combination, in a feed-cutter, of the two eccentric gear-wheels E F with each other, and with the shaft D, that carries the knife C, the shaft G, that carries the fly-wheel H, and the crank I, substantially as herein shown and described.

ROBERT J. WYLIE.

Witnesses:

WILLIAM LITTLE,  
JAS. H. HAMILTON.