

(19) World Intellectual Property Organization  
International Bureau



(43) International Publication Date  
13 December 2007 (13.12.2007)

PCT

(10) International Publication Number  
**WO 2007/140526 A1**

(51) International Patent Classification:

*E06B 9/30* (2006.01)      *A47H 5/14* (2006.01)  
*A47H 13/00* (2006.01)    *E06B 9/24* (2006.01)  
*E06B 9/26* (2006.01)    *E06B 9/28* (2006.01)

(21) International Application Number:

PCT/AU2007/000789

(22) International Filing Date: 6 June 2007 (06.06.2007)

(25) Filing Language: English

(26) Publication Language: English

(30) Priority Data:

2006903061                      6 June 2006 (06.06.2006)      AU

(71) Applicant (for all designated States except US): **TOTAL TRACK SERVICES PTY. LTD.** [AU/AU]; 91 Brunel Road, Seaford, VIC 3198 (AU).

(72) Inventor; and

(75) Inventor/Applicant (for US only): **HAILES, Donald, Craig** [AU/AU]; 91 Brunel Road, Seaford, VIC 3198 (AU).

(74) Agent: **KRAEMER, Michael; SANDERCOCK & COWIE**, 180B Sladen Street, Cranbourne, VIC 3977 (AU).

(81) Designated States (unless otherwise indicated, for every kind of national protection available): AE, AG, AL, AM, AT, AU, AZ, BA, BB, BG, BH, BR, BW, BY, BZ, CA, CH, CN, CO, CR, CU, CZ, DE, DK, DM, DO, DZ, EC, EE, EG, ES, FI, GB, GD, GE, GH, GM, GT, HN, HR, HU, ID, IL, IN, IS, JP, KE, KG, KM, KN, KP, KR, KZ, LA, LC, LK, LR, LS, LT, LU, LY, MA, MD, MG, MK, MN, MW, MX, MY, MZ, NA, NG, NI, NO, NZ, OM, PG, PH, PL, PT, RO, RS, RU, SC, SD, SE, SG, SK, SL, SM, SV, SY, TJ, TM, TN, TR, TT, TZ, UA, UG, US, UZ, VC, VN, ZA, ZM, ZW.

(84) Designated States (unless otherwise indicated, for every kind of regional protection available): ARIPO (BW, GH, GM, KE, LS, MW, MZ, NA, SD, SL, SZ, TZ, UG, ZM, ZW), Eurasian (AM, AZ, BY, KG, KZ, MD, RU, TJ, TM), European (AT, BE, BG, CH, CY, CZ, DE, DK, EE, ES, FI, FR, GB, GR, HU, IE, IS, IT, LT, LU, LV, MC, MT, NL, PL, PT, RO, SE, SI, SK, TR), OAPI (BF, BJ, CF, CG, CI, CM, GA, GN, GQ, GW, ML, MR, NE, SN, TD, TG).

Published:

— with international search report

For two-letter codes and other abbreviations, refer to the "Guidance Notes on Codes and Abbreviations" appearing at the beginning of each regular issue of the PCT Gazette.

(54) Title: BATTEN ASSEMBLY FOR ROMAN BLIND

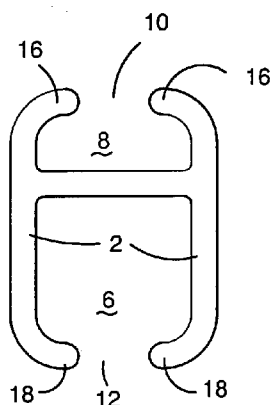

(57) Abstract: A hollow body batten having sidewalls (2) joined by a transverse wall (4) which divides the hollow body into a fabric cavity (6) and a clip cavity (8). Access to the clip cavity (8) is through a clip slot (10) which extends from end to end of the batten. Access to the fabric cavity (6) is through a fabric slot (12) which extends from end to end of the batten.



WO 2007/140526 A1

**TITLE:           BATTEN ASSEMBLY FOR ROMAN BLIND**

**FIELD OF THE INVENTION**

5   This invention concerns batten assemblies for Roman blinds.

**BACKGROUND OF THE INVENTION**

Roman blinds are raised and lowered by allowing them to form orderly folds or loops.

10   Loop formation is assisted by battens which have a series of eyes through which vertical

- 2 -

suspensory lines run and it is the lines which control the binding and release of the loops.

In US 6,257,300 a known assembly comprises a fold forming steel batten having a hollow almost circular body which defines a fabric slot running from end to end. A rod lies  
5 inside the body and traps a fold of fabric inside the body. A projecting spine on the batten body terminates in a bead. Bifurcated clips are snapped onto the bead. Each clip has an eye for the blind line.

In another known batten assembly disclosed in WO2005/044064, the same rear circular  
10 hollow batten is used with a rod to imprison a fold of fabric in the batten interior but the clips profile matches that of the near circular batten. The clips are made of resilient metal in order to snap over the body. Each clip has an eye for the blind line.

#### **SUMMARY OF THE INVENTION**

15

The apparatus aspect of the invention provides a batten assembly for a Roman blind having

- (a) an elongate hollow body with a pair of axial, mutually opposite slots; a transverse  
20 wall extending from end to end dividing the body into a clip cavity with a clip slot and a fabric cavity with a fabric slot; the fabric cavity being capable of accommodating and retaining a fold of fabric, the clip cavity being capable of admitting and retaining a clip for guiding a control line,
- 25 (b) at least two clips for guiding control lines, each clip having a part which is insertable into the clip cavity through one of the axial slots and securable by partial rotation.

The batten body may have converging walls which render the width of both slots less  
30 than the width of the transverse wall. The walls may instead be parallel with intumed flanges, but the purpose of both versions is to render the walls deformable so as to grip the inserted fabric and prevent its removal from the cavity.

- 3 -

The ends of the fabric slot may be closed by a stop. Preferably the stop closes the ends of both slots. Moulded end caps make convenient stops.

The batten may be an extrusion of lightweight material such as plastic or aluminium.

5 Metal is preferred because any deformation required is easy to impose.

The clip may have an eye for the reception of a guide control line. The clip may have a reaction surface which is urged against the body on both sides of the fabric slot when the insertable part of the clip is inserted into the slot and rotated.

10

The insertable part may be a stem with a cam surface capable of engaging with the edges of the body which define the clip slot.

The eye of the clip may be generally planar and the cam surface may be a pair of  
15 shoulders at 90° to the plane of the eye. To the assembly therefore the plane of the eyes of both clips is common and parallel to the axis of the batten body.

It is convenient to manufacture the batten stock as an aluminum or plastic extrusion with a continuous fabric cavity and a continuous clip cavity. Only the fabric cavity need be  
20 continuous from end to end so that fabric may be inserted over its entire length during the blind building stages. The clip cavity is continuous but the clip slot giving access to the clip cavity need not be. The clip slots may be incised in the cavity at the two sites where the control lines will intersect the batten. These may be 15-30mm long which is sufficient to introduce a clip.

25

### **BRIEF DESCRIPTION OF THE DRAWINGS**

One embodiment of the invention is now described with reference to the accompanying drawings, in which:

30

Figure 1 is an end section of the batten.

Figure 2 is an end view of a clip.

- 4 -

Figure 3 is a side view of the clip.

Figure 4 is a perspective of the clip.

5 Figure 5 is a fragment of a blind showing part of a batten in position.

Figure 6 is a perspective of an end cap for the batten in Figure 5.

### DETAILED DESCRIPTION WITH RESPECT TO THE DRAWINGS

10

Referring now to the drawings, the hollow body of the batten is an aluminium extrusion about 5m in length which is docked into batten lengths, up to 3000mm long. The batten is 10mm deep and 8mm wide. Sidewalls 2 are joined by transverse wall 4 which divides the hollow body into a fabric cavity 6 and a clip cavity 8.

15

Access to the clip cavity is through a clip slot 10 which extends from end to end.

Access to the fabric cavity is through a fabric slot 12 which extends from end to end of the body. Both ends are closed by moulded end caps 14 (see Figure 5). The ends 16, 18  
20 of the sidewalls are intumed in order to make the slots 3mm wide, whereas the cavities are 6mm wide.

Figures 2-4 show the construction of the clip 20. The clip is a unitary moulding in polycarbonate. The rectangular base 22 (11mm x 7mm) has a slight convexity on its  
25 undersurface. A pair of domes 24 project from the undersurface to rest in the slot 10 after insertion. Its top surface has an integral upstanding eye 26. The eye acts as a finger grip for the clip.

The ends 28 of the base are rounded and the central part of the undersurface has a  
30 downwardly projecting leg 30. Feet 32 project at 90° to the plane of the eye 26. The leg is 3mm wide and is insertable into the clip slot. An s-shaped cam surface 34 on each foot engages the curved ends of the side walls and draws the convex underface of the base tightly against the body on each side of the clip slot. Once rotated through 90° the clip

- 5 -

remains in position on the batten until reversed and slid to a new position. Thus the spacing between the clips remains at whatever spacing the installer selects.

This spacing will conform to the spacing of the control line pulleys (not shown) at the  
5 head of the Roman blind for which the battens are intended.

Figure 5 shows how the fabric is folded as if to form a seam and slid into the cavity from one open end. Nylon rod 36 imprisons the fabric fold in the fabric cavity. Optionally the batten can then be dropped into a grooved die and a presser beam is forced down upon  
10 the transverse wall to keep open the clip slot while tending to close the fabric slot. The clips are inserted at the correct spacings and rotated to lock them in position. The lines 37 are threaded through the aligned pairs of clips.

The addition of an end cap 14 to both ends of each batten improves the appearance. In  
15 Figure 6 the cap moulding has an end wall 40 and corresponds in section to the profile of the batten. Cap slot 42 corresponds with and overlies fabric slot 12. Opposite the cap slot 42 is a T-section projection 44 extending into the interior of the cap. The longitudinal edges 46 of the projection mimic the curvature of the edges 16 of the batten. A ramp face 48 ensures that the projection contacts the transverse wall 4.

20

In my co-pending Application No. 2006904526 I describe a moulded cap with a keyhole slot which fits onto the end of a batten to facilitate the introduction of the fabric and rod into the fabric cavity. These disclosures are intended to be read as related documents.

25 It is to be understood that the word "comprising" as used throughout the specification is to be interpreted in its inclusive form, ie. use of the word "comprising" does not exclude the addition of other elements.

It is to be understood that various modifications of and/or additions to the invention can  
30 be made without departing from the basic nature of the invention. These modifications and/or additions are therefore considered to fall within the scope of the invention.

**THE CLAIMS DEFINING THE INVENTION ARE AS FOLLOWS:**

1. A batten assembly for a Roman blind having
  - 5 (a) an elongate hollow body with a pair of axial, mutually opposite slots; a transverse wall extending from end to end dividing the body into a clip cavity with a clip slot and a fabric cavity with a fabric slot; the fabric cavity being capable of accommodating and retaining a fold of fabric, the clip cavity being capable of admitting and retaining a clip for guiding a  
10 control line,
  - (b) at least two clips for guiding control lines, each clip having a part which is insertable into the clip cavity through one of the axial slots and securable by partial rotation.
- 15 2. A batten assembly as claimed in Claim 1, wherein the batten body has converging walls which render the width of both slots less than the width of the transverse wall.
- 20 3. A batten assembly as claimed in Claim 1, wherein the batten body has mutually parallel walls with inturned edges for contacting the fabric and preventing its removal from the cavity.
4. A batten assembly as claimed in Claim 2 or 3, wherein the axial slot for the clips  
25 extends from end to end.
5. A batten assembly as claimed in any one of Claims 1-4, wherein the ends of the slots are closed by end caps.
- 30 6. A batten assembly as claimed in any one of the preceding claims, wherein the clip has an eye for the reception of a guide control line.

- 7 -

7. A batten assembly as claimed in Claim 6, wherein the clip has a reaction surface which in use is urged against the body on both sides of the fabric slot when the insertable part of the clip is inserted into the slot and rotated.
- 5 8. A batten assembly as claimed in Claim 7, wherein the insertable part is a stem with a cam surface capable of engaging with the edges of the body which defines the clip slot.
9. A batten assembly as claimed in any one of Claims 6-8, wherein the eye of the  
10 clip is planar and the cam surface is a pair of shoulders at 90° to the plane of the eye.
10. A batten assembly as claimed in Claim 9, wherein the plane of the eyes of a pair of clips is common and parallel to the axis of the batten body.

15

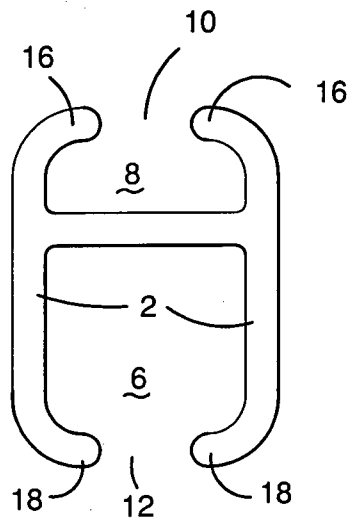

FIGURE 1

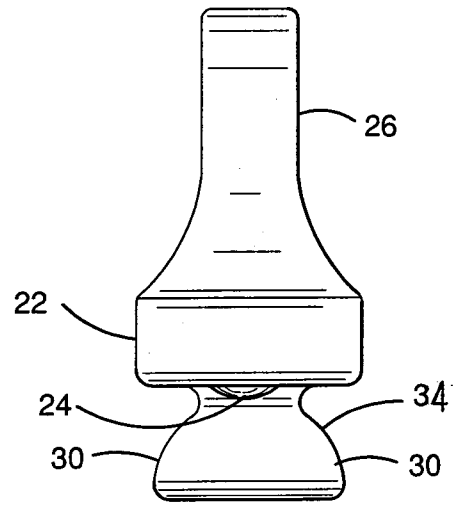

FIGURE 2

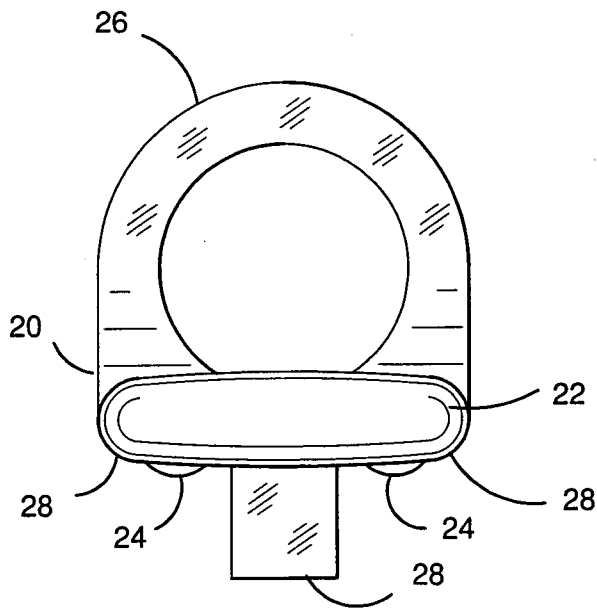

FIGURE 3

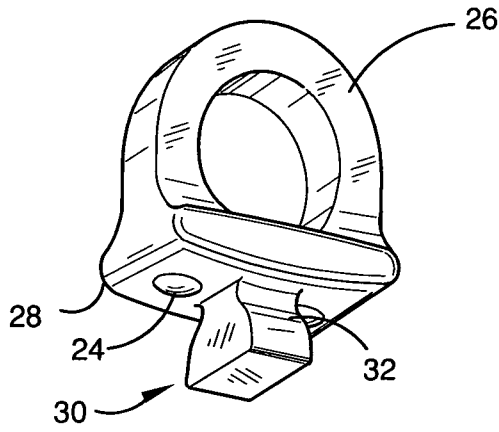

FIGURE 4

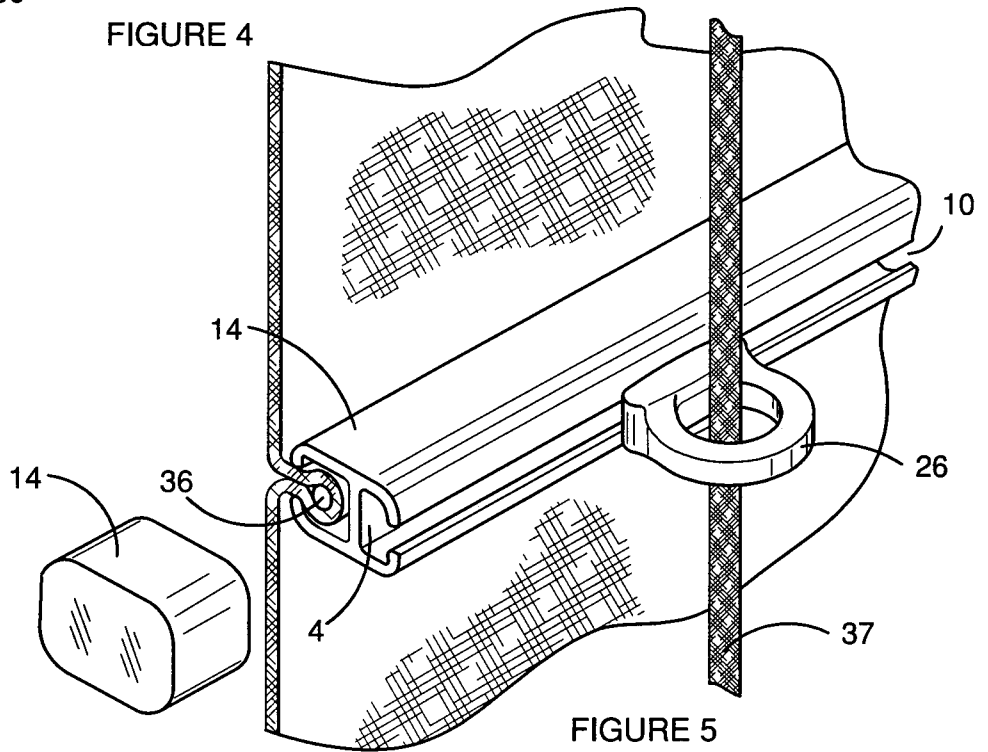

FIGURE 5

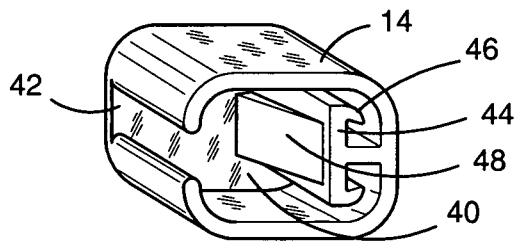

FIGURE 6

**INTERNATIONAL SEARCH REPORT**

International application No.  
**PCT/AU2007/000789**

**A. CLASSIFICATION OF SUBJECT MATTER**  
Int. Cl.  
*E06B 9/30* (2006.01)      *A47H 13/00* (2006.01)      *E06B 9/26* (2006.01)  
*A47H 5/14* (2006.01)      *E06B 9/24* (2006.01)      *E06B 9/28* (2006.01)  
According to International Patent Classification (IPC) or to both national classification and IPC

**B. FIELDS SEARCHED**  
Minimum documentation searched (classification system followed by classification symbols)  
Documentation searched other than minimum documentation to the extent that such documents are included in the fields searched  
Electronic data base consulted during the international search (name of data base and, where practicable, search terms used)  
Derwent DWPI E06B/IC, A47H/IC with keywords roman, slot, groove, recess, channel, cavity, clip, hook, loop, cord, elongate, batten, bar, rod, extrusion, sleeve, and the like.

**C. DOCUMENTS CONSIDERED TO BE RELEVANT**

Category*	Citation of document, with indication, where appropriate, of the relevant passages	Relevant to claim No.
X	US 2001/0005002 A1 (BERMAN et al.) 28 June 2001 Whole document, Figures 1 to 9	1-4, 6-9
Y		5, 10
X	WO 2001/022853 A1 (JOEL BERMAN ASSOCIATES, INC.) 5 April 2001 Whole document, Figures 1 to 9	1-4, 6-9
Y		5, 10
Y	WO 2005/044064 A1 (LOWE) 19 May 2005 Whole document, All figures	5, 10

Further documents are listed in the continuation of Box C       See patent family annex

* Special categories of cited documents:	
"A" document defining the general state of the art which is not considered to be of particular relevance	"T" later document published after the international filing date or priority date and not in conflict with the application but cited to understand the principle or theory underlying the invention
"E" earlier application or patent but published on or after the international filing date	"X" document of particular relevance; the claimed invention cannot be considered novel or cannot be considered to involve an inventive step when the document is taken alone
"L" document which may throw doubts on priority claim(s) or which is cited to establish the publication date of another citation or other special reason (as specified)	"Y" document of particular relevance; the claimed invention cannot be considered to involve an inventive step when the document is combined with one or more other such documents, such combination being obvious to a person skilled in the art
"O" document referring to an oral disclosure, use, exhibition or other means	"&" document member of the same patent family
"P" document published prior to the international filing date but later than the priority date claimed	

Date of the actual completion of the international search <b>19 June 2007</b>	Date of mailing of the international search report <b>3 - JUL 2007</b>
--	---

Name and mailing address of the ISA/AU AUSTRALIAN PATENT OFFICE PO BOX 200, WODEN ACT 2606, AUSTRALIA E-mail address: pct@ipaustrialia.gov.au Facsimile No. (02) 6285 3929	Authorized officer <b>JUDE FERNANDO</b> AUSTRALIAN PATENT OFFICE (ISO 9001 Quality Certified Service) Telephone No : (02) 6283 2419
--	---

# INTERNATIONAL SEARCH REPORT

International application No.

**PCT/AU2007/000789**

C (Continuation). DOCUMENTS CONSIDERED TO BE RELEVANT		
Category*	Citation of document, with indication, where appropriate, of the relevant passages	Relevant to claim No.
A	US 2005/0224188 A1 (NIEN) 13 October 2005 Whole document, All figures	1-10
A	US 6257300 B1 (BROWNLIE) 10 July 2001 Whole document, All figures	1-10

# INTERNATIONAL SEARCH REPORT

Information on patent family members

International application No.

**PCT/AU2007/000789**

This Annex lists the known "A" publication level patent family members relating to the patent documents cited in the above-mentioned international search report. The Australian Patent Office is in no way liable for these particulars which are merely given for the purpose of information.

Patent Document Cited in Search Report		Patent Family Member					
US	2001005002	AU	40233/01	CA	2371461	CA	2379615
		GB	2369398	GB	2373284	US	6402110
		US	6817399	US	2002190175	WO	0122853
WO	2005044064	AU	2003277985				
US	2005224188						
US	6257300	AU	44334/97	AU	45221/97	AU	47669/97
		WO	9820226	ZA	9709925		

Due to data integration issues this family listing may not include 10 digit Australian applications filed since May 2001.

END OF ANNEX