

E. I. RENDLEMAN.  
MACHINE FOR ROLLING DOUGH.  
APPLICATION FILED MAY 10, 1904.

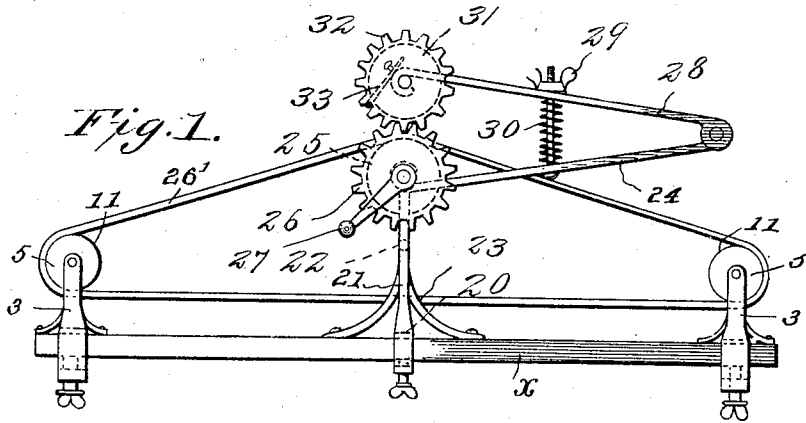

Fig. 2.

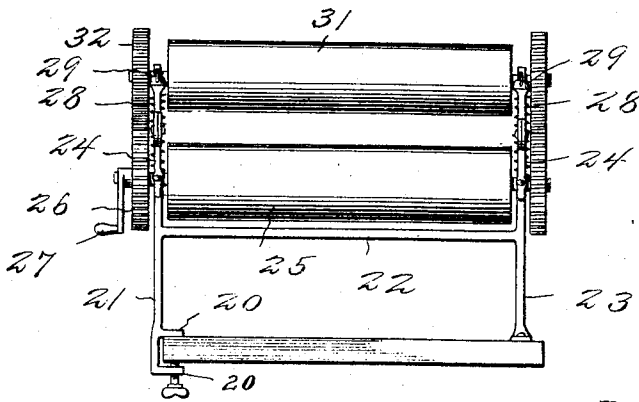

Fig. 4.

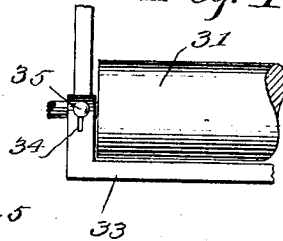
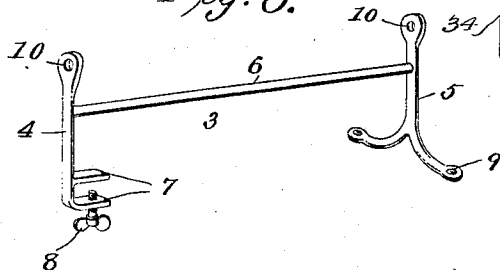

Fig. 3.



Witnesses  
*E. J. Stewart*  
*W. H. Laacke.*

*Emma I. Rendleman,*  
Inventor.

by *C. Knowles*  
Attorneys

# UNITED STATES PATENT OFFICE.

EMMA I. RENDLEMAN, OF WESTERN SARATOGA, ILLINOIS.

## MACHINE FOR ROLLING DOUGH.

SPECIFICATION forming part of Letters Patent No. 782,876, dated February 21, 1905.

Application filed May 10, 1904. Serial No. 207,290.

*To all whom it may concern:*

Be it known that I, EMMA I. RENDLEMAN, a citizen of the United States, residing at Western Saratoga, in the county of Union and State of Illinois, have invented a new and useful Machine for Rolling Dough, of which the following is a specification.

This invention relates to machines for rolling dough and similar material into sheets, its principal object being to provide a machine of the knockdown variety which may be readily packed into small space when not in use and quickly adjusted to operative position without the necessity of employing skilled labor.

With this and other objects in view, as will more fully hereinafter appear, the invention consists in certain novel features of construction and arrangement of parts hereinafter fully described, illustrated in the accompanying drawings, and particularly pointed out in the appended claims, it being understood that various changes in the form, proportions, size, and minor details of the structure may be made without departing from the spirit or sacrificing any of the advantages of the invention.

In the accompanying drawings, Figure 1 is a side elevation of a machine constructed in accordance with the invention. Fig. 2 is an elevation of the central bracket member detached. Fig. 3 is a detail perspective view of one of the end brackets. Fig. 4 is a sectional plan view of a portion of the device, illustrating more particularly the scraping-knife.

Similar characters of reference are employed to indicate corresponding parts throughout the several figures of the drawings.

The various parts of the apparatus are mounted on a table or other support *x*.

The brackets 3, which are two in number, each include a vertical standard 4 and a standard 5, the two standards being coupled together by a cross-bar 6. The standard 4 is provided at its lower end with a pair of inwardly-turned lugs 7, one of which is tapped for the reception of a clamping-screw 8 to engage against the under side of a table or other support. The opposite standard 5 is bifurcated

and forms two spaced arms, that may be provided with openings 9 for the passage of securing-screws, if necessary. The upper ends of the two standards are provided with openings 10 for the reception of the end pintles of rollers 11, which may be formed of wood or other suitable material.

Between the two end brackets is a central bracket including a pair of standards 21 and 23, the standard 21 being provided with a pair of lugs 20, one of which is adapted for the reception of a suitable clamping-screw. These standards are united by a cross-bar 22 and are continued upward to form bearings for the end pintles of a roller 25, one of said pintles projecting some distance from the end of the bracket and being provided with an operating-crank 27. The upright standards, at a point slightly below the journal of the roller 25, carry obliquely-disposed arms 24, to the outer ends of which are pivoted arms 28, and the two arms are disposed on divergent lines and connected by a threaded rod 29, having a screw which may be turned to draw the arms toward each other. At a point between the two arms a spring 30 surrounds the threaded rod and tends to separate the arms. The ends of the arms 28 are turned in such manner as to form bearings for the reception of end pintles of an upper roller 31, and the pintles of both rollers are provided at the opposite ends with intermeshing gears, there being two gears 26 for the lower roller and two gears 32 for the upper roller, said gears being of the same diameter and the rollers revolving at the same surface speed. By turning the screw 29 in one direction or the other the distance between the rollers may be regulated in accordance with the desired thickness of the sheet of dough. Over the two end rolls and the lower roller 25 passes an endless belt 26', formed of canvas or other flexible material, and on which the dough is placed to be rolled.

Secured to the ends of the arms 28 are the opposite end of a scraping-blade 33, said blade being arranged to work close to the upper roller and prevent the dough clinging thereto. The connection between the scraper-

blade and the arms may be adjustable, as shown, the ends of the blades being slotted at 34 for the passage of thumb-screws 35.

5 With a device of this character it is possible to roll the dough into sheets of any desired thickness, and is of especial value in making some forms of pastry, such as pie-crust and patties, where the dough is folded after each rolling operation.

10 Having thus described the invention, what is claimed is—

1. The combination in a dough-rolling machine, of a plurality of spaced brackets adjustable toward and from each other, rollers supported by the brackets, an endless belt 15 passing over the rollers, an auxiliary top roller in alinement with the central of said rollers, pivotally-mounted arms forming bearings for said top roller, a spring tending to raise the arms, and an adjustable means for 20

depressing said arms and moving the roller in the direction of the belt.

2. A dough-rolling machine comprising a clamp, an upright thereon, a pair of legs, a cross-bar connecting the upright and legs, a pair of inclined stationary arms on the cross-bar, a roller journaled on said arms, an arm pivoted to the upper end of each of the inclined arms, thumb-screws and springs for adjusting the pivoted arms toward and from the stationary arms, a roller journaled on the pivoted arms, and a scraper adjacent to the periphery of the last-mentioned roller.

In testimony that I claim the foregoing as my own I have hereto affixed my signature in the presence of two witnesses.

EMMA I. RENDLEMAN.

Witnesses:

ALICE L. WILLOUGHBY,  
H. P. TUTHILL.