

(19) World Intellectual Property Organization  
International Bureau



(43) International Publication Date  
1 March 2001 (01.03.2001)

PCT

(10) International Publication Number  
**WO 01/14248 A2**

- (51) International Patent Classification<sup>7</sup>: **B81C 3/00**
- (21) International Application Number: PCT/US00/40661
- (22) International Filing Date: 16 August 2000 (16.08.2000)
- (25) Filing Language: English
- (26) Publication Language: English
- (30) Priority Data:  
09/379,414 24 August 1999 (24.08.1999) US
- (71) Applicant: **KNOWLES ELECTRONICS, LLC**  
[US/US]; 1151 Maplewood Drive, Itasca, IL 60143 (US).
- (72) Inventors: **PEDERSEN, Michael**; 96 Gant Circle #H,  
Streamwood, IL 60107 (US). **LOEPPERT, Peter, V.**; 2028  
Timber Ridge Lane, Hoffman Estates, IL 60195 (US).
- (74) Agents: **MORNEAULT, Monique, A.** et al.; Wallenstein  
& Wagner, Ltd., 311 South Wacker Drive - 5300, Chicago,  
IL 60606-6622 (US).
- (81) Designated States (*national*): AE, AG, AL, AM, AT, AU,  
AZ, BA, BB, BG, BR, BY, BZ, CA, CH, CN, CR, CU, CZ,  
DE, DK, DM, DZ, EE, ES, FI, GB, GD, GE, GH, GM, HR,  
HU, ID, IL, IN, IS, JP, KE, KG, KP, KR, KZ, LC, LK, LR,  
LS, LT, LU, LV, MA, MD, MG, MK, MN, MW, MX, MZ,  
NO, NZ, PL, PT, RO, RU, SD, SE, SG, SI, SK, SL, TJ, TM,  
TR, TT, TZ, UA, UG, UZ, VN, YU, ZA, ZW.
- (84) Designated States (*regional*): ARIPO patent (GH, GM,  
KE, LS, MW, MZ, SD, SL, SZ, TZ, UG, ZW), Eurasian  
patent (AM, AZ, BY, KG, KZ, MD, RU, TJ, TM), European  
patent (AT, BE, CH, CY, DE, DK, ES, FI, FR, GB, GR, IE,  
IT, LU, MC, NL, PT, SE), OAPI patent (BF, BJ, CF, CG,  
CI, CM, GA, GN, GW, ML, MR, NE, SN, TD, TG).
- Published:**  
— Without international search report and to be republished  
upon receipt of that report.
- For two-letter codes and other abbreviations, refer to the "Guidance Notes on Codes and Abbreviations" appearing at the beginning of each regular issue of the PCT Gazette.

(54) Title: ASSEMBLY PROCESS FOR DELICATE SILICON STRUCTURES

20

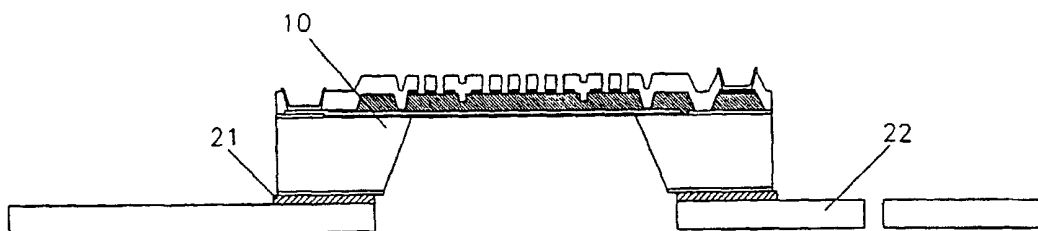

(57) Abstract: A method for fabrication of silicon structures is disclosed. The method includes providing an acoustic transducer having a perforated member spaced from a diaphragm. Between the perforated member and the diaphragm is a sacrificial layer. After attaching the transducer to a carrier, the sacrificial layer is removed.



WO 01/14248 A2

## ASSEMBLY PROCESS FOR DELICATE SILICON STRUCTURES

### DESCRIPTION

#### Technical Field

The present invention relates to the assembly process of miniature sensors. More specifically, the present invention provides for protection of mechanically sensitive sensor structures during high stress procedures such as dicing and picking-and-placing.

#### 5 Background of the Invention

The utilization of micro machining technology makes possible the fabrication of micrometer sized structures. The term silicon micro machining is typically used to describe the formation of mechanical structures on silicon wafers using a combination of deposition and etching of thin films and potentially etching of the silicon wafer. In the  
10 formation of many structures, one or more of the thin film layers are used as sacrificial layers, upon removal of which the final structure is realized. The sacrificial layers help maintain sufficient robustness of the structure during the wafer fabrication process. Traditionally, the final wafer processing procedure is to remove the sacrificial layers and dry the structures to prevent stiction.

15 The major problem with this process is, in order to package the sensor structures, they must first be separated from the wafer. The most common method for separation is dicing of the wafer using a high speed diamond blade or a laser. Alternatively, the wafer can be scribed and cleaved along the crystal orientation. Scribing is generally very damaging to mechanical structures on the wafer due to the  
20 extremely high stress levels during the cleaving process and debris left from breaking. The dicing process presents other problems. The laser dicing tends to heat up the wafer and produces a significant amount of residue which gets in the tiny gaps of an

unprotected sensor structure and potentially render it useless. Furthermore, the heat generated may lead to excessive temperature strain on the sensor structure. Blade dicing is much lower cost than laser dicing, but is also much less clean since the wafer surface must be flooded with lubricant, typically water, to keep the temperature of the wafer and diamond blade in proper operating range. In blade dicing, the lubricant and dicing slurry penetrate any open structure and render it useless. Furthermore, the lubricant is typically sprayed onto the wafer surface at high speed, the mechanical load of which can easily break and destroy the delicate sensor structure.

Another issue involves the handling of the structures when separated. Transferring the delicate structures to a package becomes quite cumbersome, since conventional vacuum/contact pick and place methods cannot be applied without potential damage to the structure. This leads to complications and customization of the assembly equipment, which otherwise could be standard IC die attach equipment.

Several methods exist for protecting the structures during dicing. One method is to apply a layer of organic material (i.e., photo resist) on the surface of the wafer. This layer encloses the structure and protects it during the dicing process. Afterwards, the layer is removed with a solvent or a dry etch process. The most significant problem with this process is application of the layer, which is typically a spin-on process. This process can be too stressful on some structures (i.e., due to the vacuum applied to the wafer during spinning). Furthermore, it can be difficult to fully remove the material after the dicing process, leaving some residue inside the structure. Finally, the application and subsequent removal of a protection layer adds to the complexity of the fabrication process.

Another approach is to seal off the sensor structure with another wafer, which would usually have a cavity etched in order not to mechanically load the structure. Prior to dicing, the two wafers are bonded, whereby the sensor structures are sealed off from the environment and the two wafers are then diced as a sandwich. This works well for structures that need to be sealed anyway (i.e., accelerometers and resonators); however,

it cannot be applied if the structures must remain open (i.e., microphones and relative pressure sensors).

#### Summary of The Invention

5 The present invention provides a method for fabrication of silicon structures including acoustic transducers. In an embodiment, the method includes providing an acoustic transducer having a perforated member spaced from a diaphragm. Between the perforated member and the diaphragm is a sacrificial layer. After attaching the transducer to a carrier, the sacrificial layer is removed.

#### Brief Description of the Drawings

10 FIGURE 1 is a cross-sectional view of a typical structure made by silicon micro machining;

FIGURE 2 is a cross-sectional view taken along the line A-A in FIGURE 3 of an assembly in accordance with the present invention;

FIGURE 3 is a top plan view of the assembly of FIGURE 2; and,

15 FIGURE 4 is a cross-sectional view of the assembly of FIGURE 2 in which the sacrificial layer has been removed in the micro mechanical sensor and the sensor has been electrically connected using bond wires.

#### Detailed Description

20 While this invention is susceptible of embodiment in many different forms, there is shown in the drawings and will herein be described in detail preferred embodiments of the invention with the understanding that the present disclosure is to be considered as an exemplification of the principles of the invention and is not intended to limit the broad aspect of the invention to the embodiments illustrated.

25 The invention results from the realization that the inherent sacrificial layer in the sensor structure can be utilized to provide adequate mechanical robustness during the dicing and pick-and-place process. If the sacrificial layer is not removed from the structure until the structure has been placed in the package, the issues of mechanical protection during dicing and placing can be eliminated. Furthermore, if a chemically

resistant package is selected, standard sacrificial layers, such as silicon oxide, and etching chemicals, such as hydrofluoric acid, can be used.

5 This invention features a procedure in which the silicon sensor structure is cut from a silicon wafer and placed on a package carrier before the silicon processing of the sensor structure has been completed. Once the structure has been placed on the carrier, the sacrificial layer in the structure is removed by chemical etching. The package carrier and the material with which the silicon sensor is attached to the carrier are chosen such that the assembly can withstand the process of chemical etching.

10 In a preferred implementation of the procedure, a stabilizing sacrificial layer is used in the silicon sensor structures. The sacrificial layer can be made from one or more of the materials from the group consisting of silicon, germanium, polycrystalline silicon, silicon oxide, silicon nitride, aluminum, or other suitable materials. The wafer containing the silicon structures is separated before the sacrificial layer is removed. The method of separation can be one of the following: cutting using high-speed diamond  
15 blade; cutting using laser, scribing using diamond and subsequent cleaving. The sensor is subsequently picked and placed on a package carrier. The package carrier can be made from one or more of the materials from the group consisting of carbon-based polymers, glass, aluminum oxide, silicon nitride, silicon oxide, silicon carbide, tungsten carbide, boron oxide, copper, carbon, nickel, silver, gold, palladium, platinum, aluminum,  
20 titanium, iron, tantalum, chromium, tungsten, silicon and their alloys, or other suitable materials. The sensor is attached to the carrier using a chemically resistant adhesive. The carrier with the sensor is then subjected to a chemical etching process in which the sacrificial layer in the sensor is removed. The etching process can involve a series of aqueous chemical solutions or a reactive vapor phase etchant. After etching, the carrier  
25 and sensor are dried using one of the following methods: supercritical drying, liquid evaporation, freeze drying. The materials for the package carrier and attach adhesive are chosen to be chemically resistant to all chemicals involved in the etching and drying

process. Furthermore, if a matrix type carrier is used (i.e., lead frame matrices), this allows processing with magazine handling of many devices per process batch.

There is shown in FIG. 1 a typical silicon structure **10** as used in the procedure according to this invention. The structure consists of one or more mechanical layers **11**, which have been formed on a substrate **13**, and the separation between which has been set by the thickness of one or more sacrificial layers **12**. During fabrication, many sensor structures **10** are formed simultaneously on a silicon wafer, and upon completion the wafer is diced and each structure is picked and placed on a lead frame carrier **22** shown in FIG. 2 forming the assembly **20**. In an embodiment, the sensor structures can be acoustic transducers or the like such as disclosed in U.S. Patent No. 5,452,268 to Bernstein, incorporated herein by reference. The transducer includes a perforated member, separated from a diaphragm, with a sacrificial layer therebetween.

The silicon structure is attached to the carrier **22** using an adhesive **21**, or can be attached using other methods such as eutectic bonding. The adhesive **21** and lead frame carrier **22** are made from materials that withstand exposure to etchants for the removal of the sacrificial layers **12** and the subsequent drying process of the silicon structure **10**. The assembly **20** is entirely exposed to the sacrificial layer etchant, which upon drying forms the final silicon structure **30** in FIG. 4. From this point onwards, a standard integrated circuit assembly procedure can be used to electrically connect the silicon structure using bond wires **23** and to encapsulate the structure.

While the specific embodiments have been illustrated and described, numerous modifications come to mind without significantly departing from the spirit of the invention and the scope of protection is only limited by the scope of the accompanying Claims.

What is claimed is:

1. A method comprising the steps of:  
providing a wafer;  
dicing from the wafer a silicon structure having at least one internal sacrificial  
5 layer;  
picking and placing the silicon structure onto a substrate carrier;  
attaching the silicon structure onto the substrate carrier;  
removing the sacrificial layer by subjecting the substrate carrier and silicon  
structure to a chemical dissolution process; and,  
10 subjecting the substrate carrier and silicon structure to a drying process.
2. The method of claim 1 wherein the step of dicing includes the steps of  
attaching the wafer to dicing tape and cutting the wafer using a high speed diamond  
blade.
3. The method of claim 1 wherein the step of dicing includes the step of cutting  
15 the wafer using a laser.
4. The method of claim 1 wherein the step of dicing includes the steps of  
scribing the wafer using a diamond and cleaving the wafer using mechanical force.
5. The method of claim 1 wherein the silicon structure includes a surface and  
the step of picking-and-placing includes the step of using a vacuum fixation on the  
20 surface of the silicon structure.
6. The method of claim 1 wherein the silicon structure includes a perimeter and  
the step of picking-and-placing includes the step of using mechanical fixation along the  
perimeter of the silicon structure.
7. The method of claim 1 wherein the step of attaching the structure to the  
25 carrier includes using an adhesive, eutectic bonding, electrostatic bonding or fusion  
bonding.

8. The method of claim 1 wherein the step of attaching the structure to the carrier includes the step of providing an epoxy material for attaching the structure to the carrier.
9. The method of claim 1 wherein the substrate carrier is a metal lead frame.
- 5 10. The method of claim 1 wherein the step of removing the sacrificial layer includes either a liquid or vapor phase chemical etching.
11. The method of claim 1 wherein the step of removing the sacrificial layer includes providing a hydrofluoric acid for removing the sacrificial layer.
12. The method of claim 1 wherein the step of drying the silicon structure is performed by evaporation or sublimation of a liquid or solid base chemical in the silicon structure.
- 10 13. A method comprising the steps of:  
providing an acoustic transducer having a perforated member spaced from a diaphragm with a sacrificial layer therebetween;  
15 attaching the transducer to a carrier; and,  
removing the sacrificial layer after attaching the transducer to the carrier.
14. The method of claim 13 further including the step of providing a silicon wafer with the acoustic transducer formed thereon.
15. The method of claim 14 wherein the silicon wafer includes another acoustic transducer formed thereon.
- 20 16. The method of claim 14 further including the step of dicing the wafer to separate the transducer from the wafer.
17. The method of claim 16 wherein the step of dicing includes at least one step consisting of cutting the wafer using a diamond blade, cutting the wafer using a laser, and scribing the wafer.
- 25 18. The method of claim 13 further including the step of placing the transducer on a carrier.

19. The method of claim **18** further including the step of attaching the transducer to the carrier.
20. The method of claim **13** further including the step of exposing the transducer to an etchant.
- 5 21. The method of claim **13** wherein the etchant is hydrofluoroic acid.
22. The method of claim **13** wherein the sacrificial layer is made from at least one material consisting of silicon, germanium, polycrystalline silicon, silicon oxide, silicon nitride, and aluminum.
24. The method of claim **13** wherein the carrier is made form at least one material  
10 consisting of a carbon-based polymer, glass, aluminum oxide, silicon nitride, silicon oxide, silicon carbide, tungsten carbide, boron oxide, copper, carbon, nickel, silver, gold, palladium, platinum, aluminum, titanium, iron, tantalum, chromium, and tungsten.
25. The method of claim **13** further including the step of drying the carrier and the transducer.
- 15 26. The method of claim **25** wherein the step of drying includes at least one step consisting of supercritical drying the transducer, evaporating liquid from the transducer, and freeze drying the transducer.
27. The method of claim **13** further including the step of allowing the diaphragm to move, upon removal of the sacrificial layer, in response to an incident acoustic signal.

FIG. 1

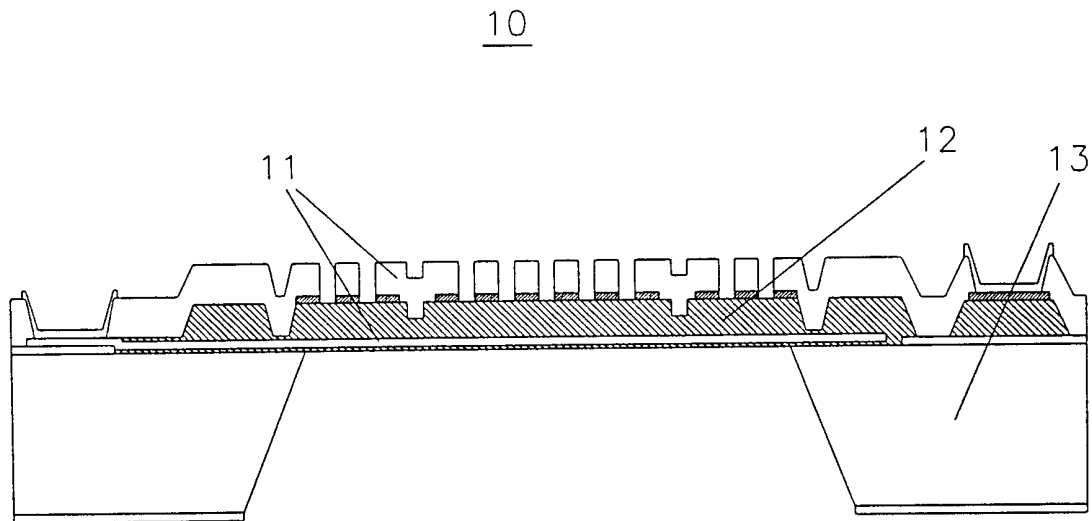

FIG. 2

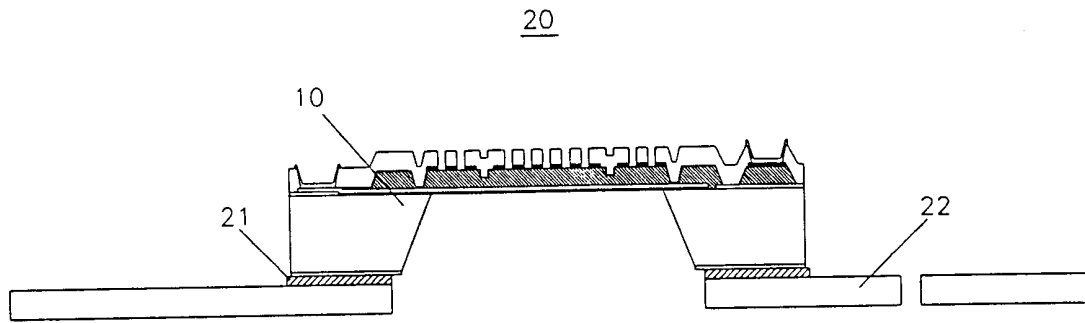

FIG. 3

20

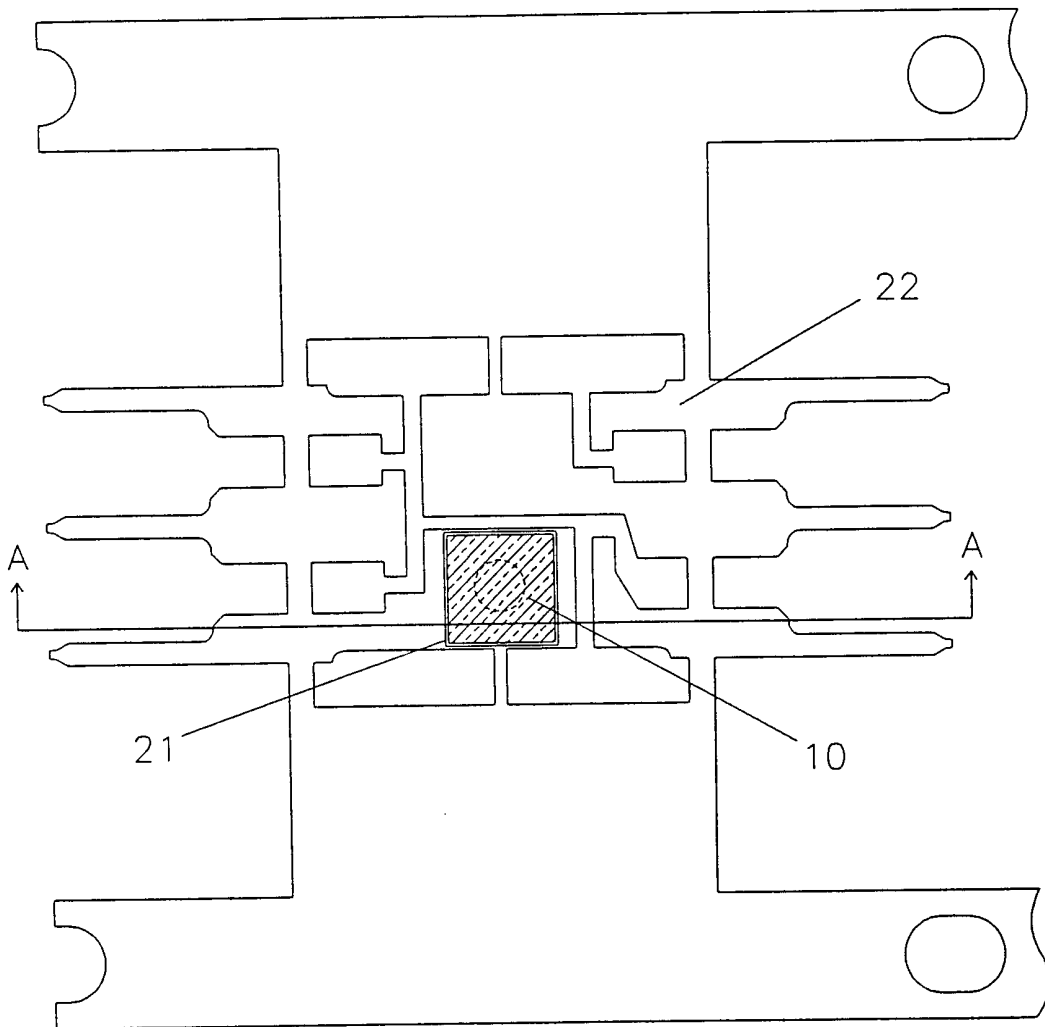

FIG. 4

