



US 20050000996A1

(19) **United States**

(12) **Patent Application Publication**
Petravic

(10) **Pub. No.: US 2005/0000996 A1**

(43) **Pub. Date: Jan. 6, 2005**

(54) **CARRYING CASE FOR PORTABLE ELECTRONIC DEVICE**

Publication Classification

(76) **Inventor: Robin Petravic, Sausalito, CA (US)**

(51) **Int. Cl.⁷ A45F 3/04**

(52) **U.S. Cl. 224/642**

Correspondence Address:
COLLIER SHANNON SCOTT, PLLC
3050 K STREET, NW
SUITE 400
WASHINGTON, DC 20007 (US)

(57) **ABSTRACT**

(21) **Appl. No.: 10/699,672**

(22) **Filed: Nov. 4, 2003**

Related U.S. Application Data

(60) **Provisional application No. 60/426,415, filed on Nov. 15, 2002.**

A carrying case for a portable electronic device includes a plurality of wall portions defining a compartment for receiving the portable electronic device. A shock absorber is associated with at least one of the wall portions, and includes a leaf spring that is configured and dimensioned to absorb at least a portion of any forces that are transmitted through the wall portion to the portable electronic device.

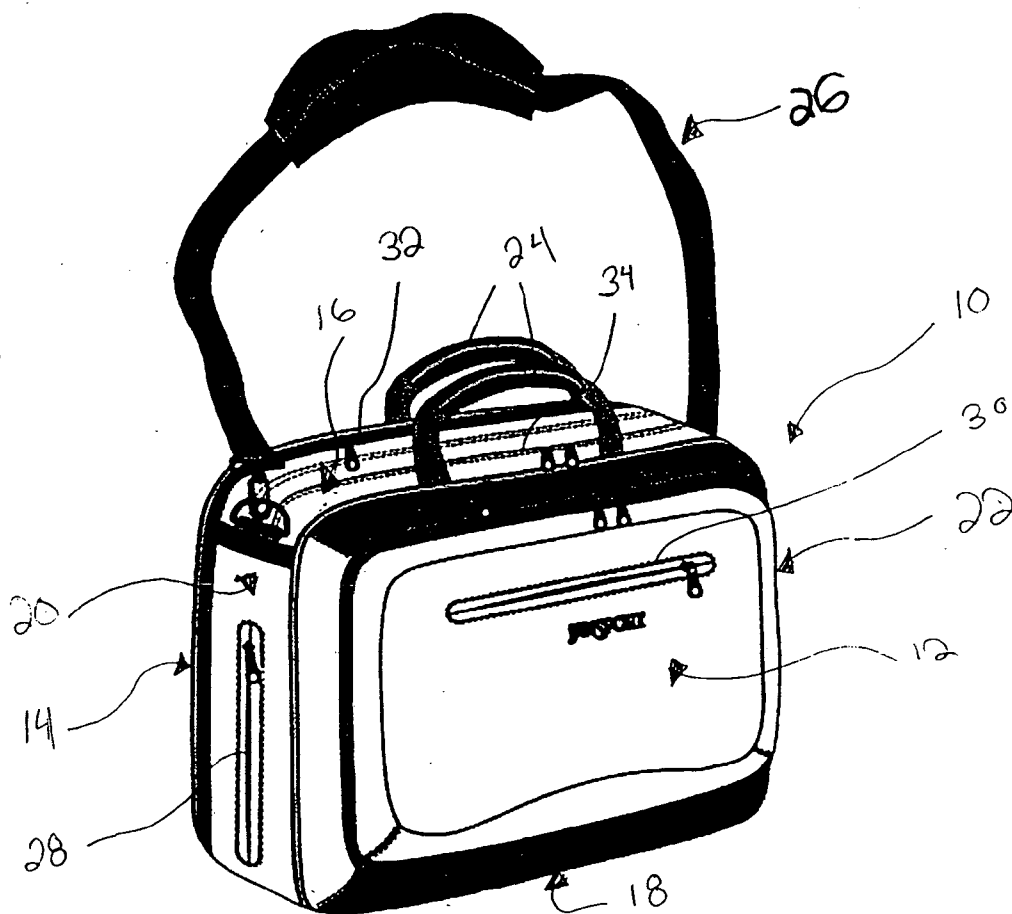

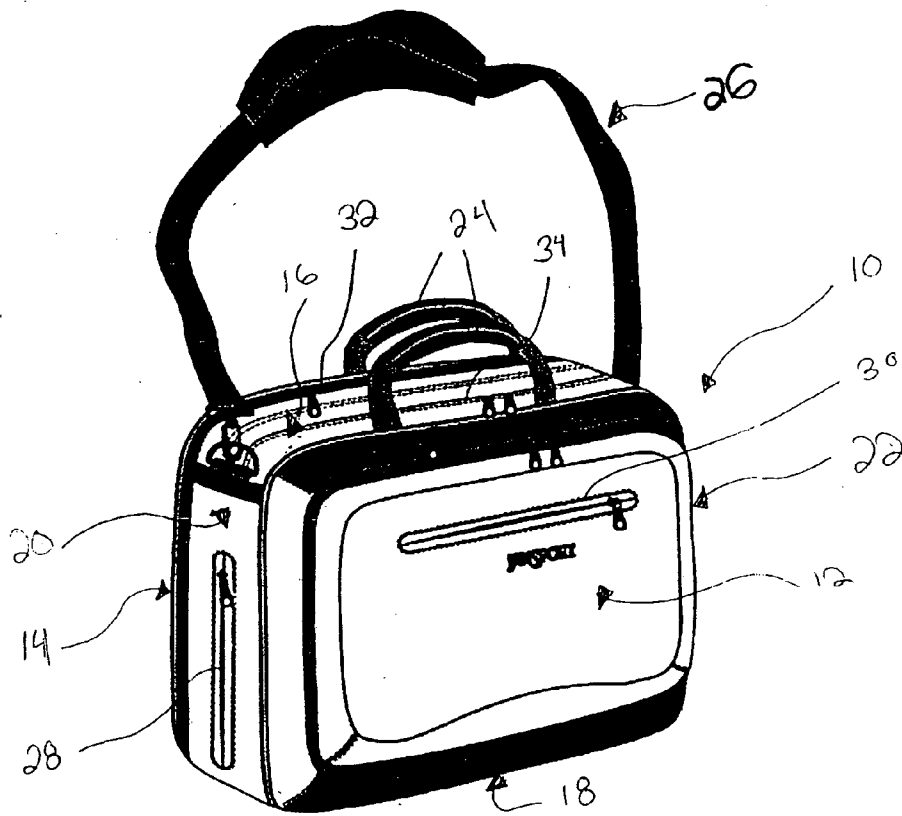

FIG. 1

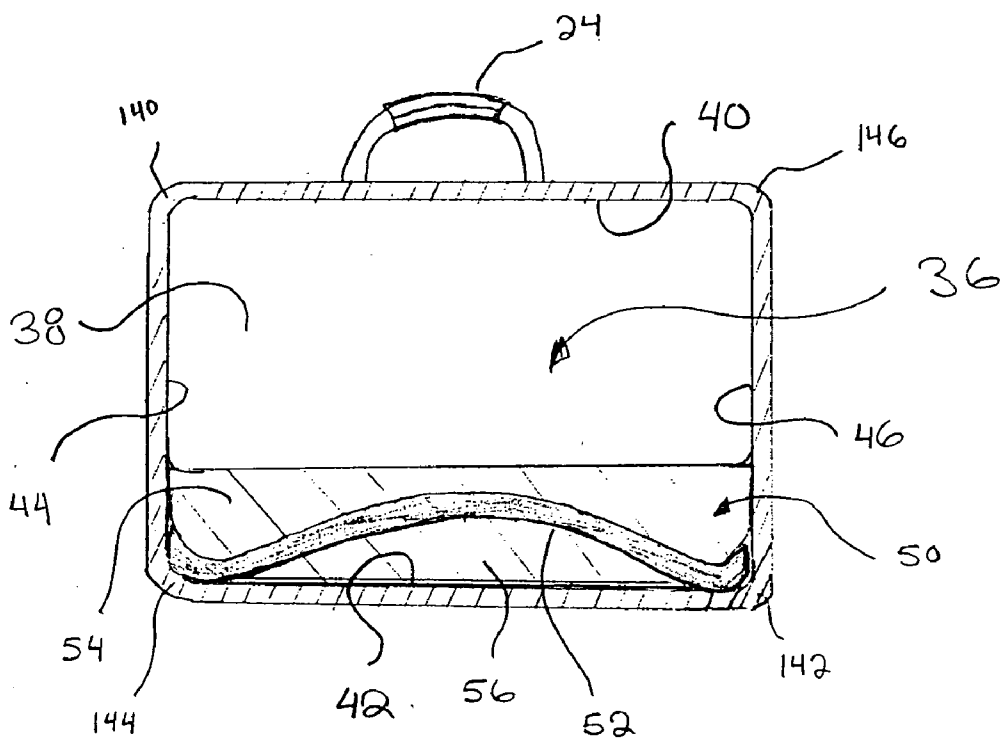
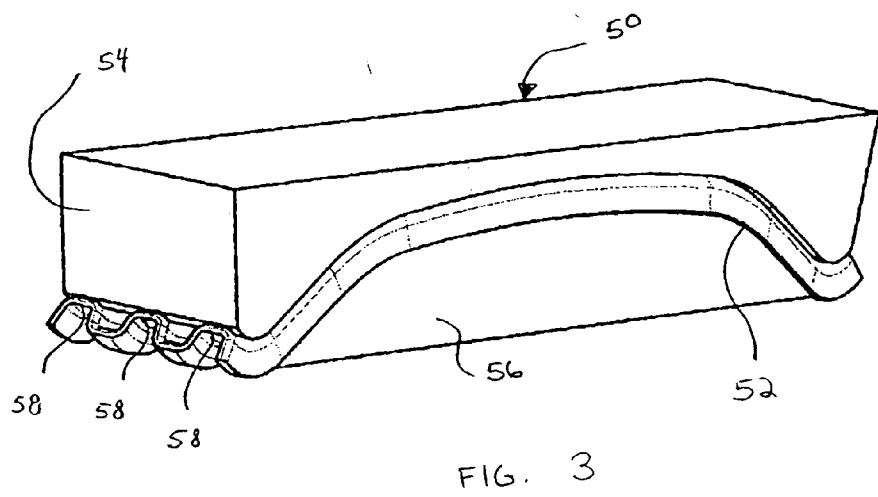
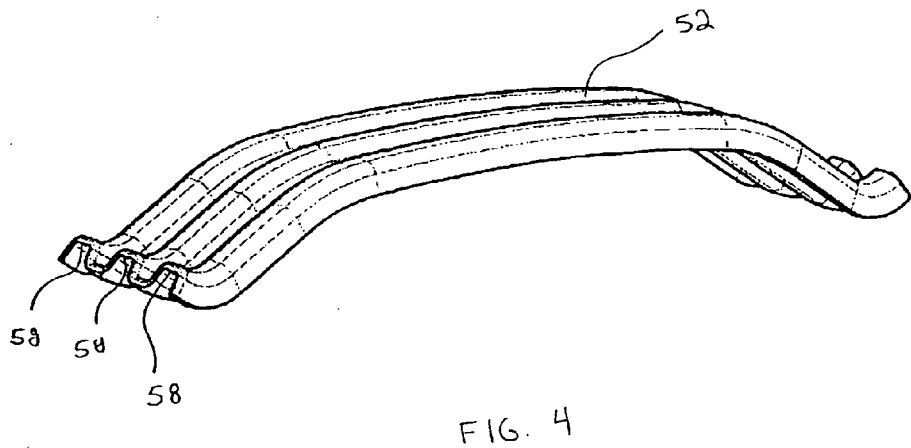
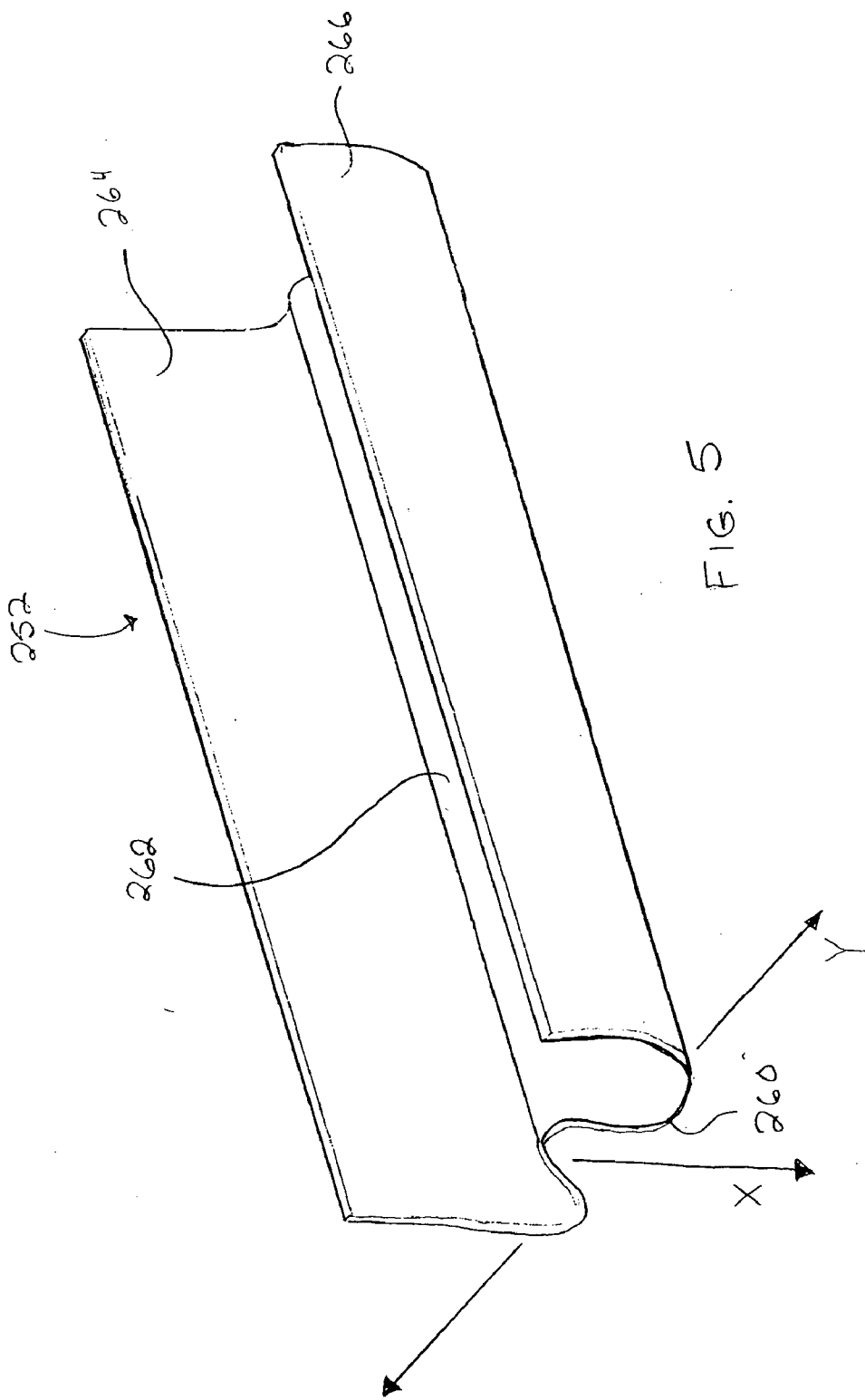

FIG. 2





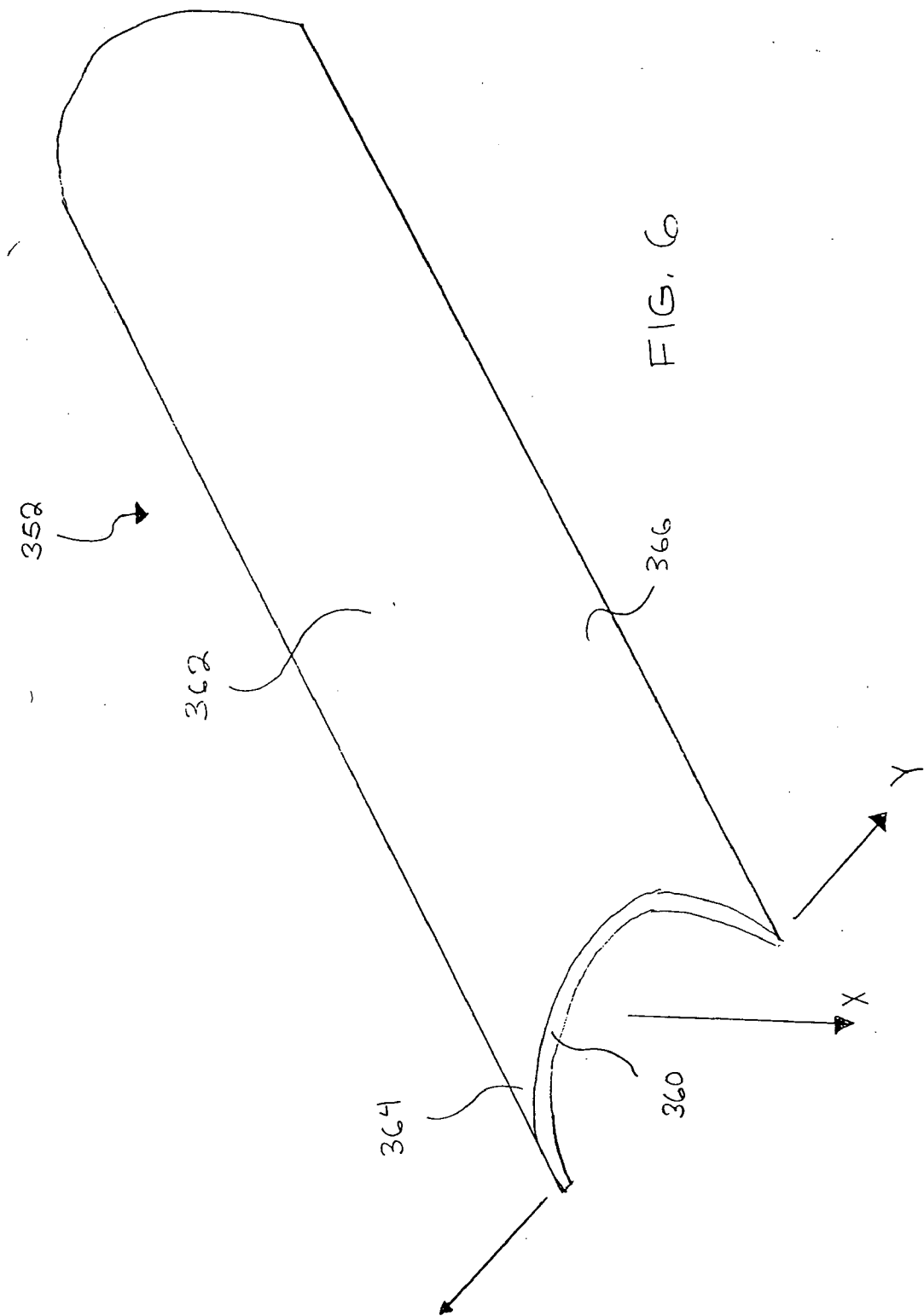



FIG. 7

CARRYING CASE FOR PORTABLE ELECTRONIC DEVICE

SUMMARY OF THE INVENTION

[0001] The present invention is directed to a carrying case for a portable electronic device. The carrying case includes a plurality of wall portions defining a compartment for receiving the portable electronic device. A shock absorber is associated with at least one of the wall portions, and includes a leaf spring that is configured and dimensioned to absorb at least a portion of any forces that are transmitted through the wall portion to the portable electronic device. The case may include a bottom wall configured and dimensioned for resting on the ground, and the shock absorber may be associated with the bottom wall.

[0002] According to one aspect of the present invention, the shock absorber further includes foam padding surrounding at least a portion of the leaf spring. The foam padding may substantially conform to the shape of the leaf spring.

[0003] According to another aspect of the present invention, the leaf spring may include one or more reinforcing channels extending substantially longitudinally along the leaf spring. Alternatively, the leaf spring may have a generally "W"-shaped or "U"-shaped cross-section.

BRIEF DESCRIPTION OF THE DRAWINGS

[0004] The detailed description will be better understood in conjunction with the accompanying drawings, wherein like reference characters represent like elements, as follows:

[0005] FIG. 1 is a perspective view of the exterior of a first exemplary embodiment of a carrying case according to the present invention;

[0006] FIG. 2 is a cross-sectional view of the carrying case of FIG. 1;

[0007] FIG. 3 is a perspective view of one exemplary embodiment of a shock absorber according to the present invention;

[0008] FIG. 4 is a perspective view of one exemplary embodiment of a leaf spring of the shock absorber of FIG. 3;

[0009] FIG. 5 is a perspective view of a second exemplary embodiment of the leaf spring of the shock absorber of FIG. 3;

[0010] FIG. 6 is a perspective view of a third exemplary embodiment of the leaf spring of the shock absorber of FIG. 3; and

[0011] FIG. 7 is a perspective view of the exterior of a second exemplary embodiment of a carrying case according to the present invention.

DETAILED DESCRIPTION OF THE PREFERRED EMBODIMENTS

[0012] Referring to FIG. 1, a first exemplary embodiment of a carrying case according to the present invention is shown as reference number 10. Case 10 is described herein as a case for a portable computer, however, case 10 may alternatively be sized and dimensioned for carrying any

number of other portable electronic devices, such as calculators, personal digital assistants, printers, scanners, or the like.

[0013] Case 10 includes a plurality of exterior wall sections including a front wall 12, a back wall 14, a top wall 16, a bottom wall 18, and side walls 20, 22. Bottom wall 18 may be configured and dimensioned to rest on the ground and support case 10 in an upright position while it is not being carried by a user. Although case 10 is shown as having a generally box-like shape, it is not limited to the shape shown, and may include any number of exterior walls having any shape or size known in the art. Case 10 may optionally include a pair of handles 24, and/or a shoulder strap 26 to assist in carrying the case 10. Case 10 may be constructed from any number and combination of materials, including, without limitation, 600D Polyester, 600D Mini Ripstop, 420 Packcloth, 210 Packcloth, 500D Cordura, 1000D Cordura, 1680D Ballistic, 840D Jr. Ballistic, Dobbies and Nailhead, or any other suitable material known to one of ordinary skill in the art. It should be noted that the scope of the present invention is not limited to the material or type of construction of case 10.

[0014] Still referring to FIG. 1, case 10 may also include one or more pockets. For example, case 10 may include a pocket 28 for holding a power supply cable or other accessories for a portable computer. Additionally or alternatively, case 10 may include another pocket 30 for holding computer accessories, such as a disk drive, computer disks, battery packs, PCMCIA cards, modems, or any other computer-related devices known in the art. One or more pockets 32 may also be included for storing papers, documents, folders, and the like. Pockets 28, 30, and 32 may be closeable via zippers, hook-and-loop type fasteners, snaps, or any other type of fasteners known to one of ordinary skill in the art.

[0015] Case 10 may also include an opening 34, for providing access to a compartment 36 (shown in FIG. 2) for storing the portable computer. As shown in FIG. 1, opening 34 may be closeable via a zipper, or alternatively via hook-and-loop type fastener, snaps, or any other type of fasteners known to one of ordinary skill in the art. As shown in FIG. 1, opening 34 may extend along just one of the exterior wall sections, or alternatively, opening 34 may extend along two or more of the exterior wall sections, such that the compartment opens like a clamshell.

[0016] Referring to FIG. 2, compartment 36 may be defined by any number of wall portions that are configured and dimensioned to receive a portable computer. In the exemplary embodiment shown, compartment 36 is defined by a front wall (not shown), a back wall 38, a top wall 40, a bottom wall 42, and side walls 44, 46. It should be noted, however, that the present invention is not limited to this or any other shape of compartment 36 or case 10. Thus, as mentioned above, the shape and/or size of case 10 may be varied for various reasons, such as to accommodate specific uses of the case 10, or to meet a certain stylistic or fashion need. Still referring to FIG. 2, a shock absorber 50 may be associated with one or more of the wall portions, such as bottom wall 42. Shock absorber 50 may be formed integrally with case 10 (e.g., by locating it underneath the liner material of case 10), may be a separate unit that is attachable to the interior of case 10 (e.g., by hook and loop fastener material), or may be otherwise associated with the wall so

that it is located between the wall and the computer—shock absorber **50** may even be spaced from the wall. The shock absorber may be associated with any of the wall portions of compartment **36**. For example, a second shock absorber **50** may be associated with top wall **40**, and third and fourth shock absorbers may be associated with the side walls **44**, **46**.

[0017] Turning to FIGS. 3 and 4, one exemplary embodiment of shock absorber **50** is shown in detail. Shock absorber **50** may include a leaf spring **52** that is configured and dimensioned to deflect under impact and absorb at least a portion of any forces that are transmitted through the wall portion to the portable computer, thus reducing the risk of damage to the computer. Leaf spring **52** may extend along a substantial portion of the wall portion (e.g., along more than half of the length of the wall portion). According to the illustrative embodiment shown in FIGS. 2-4, leaf spring **52** extends along bottom wall **42** from a first corner **142** to a second corner **144**. As shown, the leaf spring **52** may be located substantially adjacent the wall portion at the first and second corners **142**, **144**, with the portion of the leaf spring **52** located between the corners **142**, **144** being spaced apart from the wall portion. As also shown, the leaf spring **52** may extend along an arcuate path from the first corner **142** to the second corner **144**.

[0018] According to one embodiment of the present invention, leaf spring **52** may be constructed of a semi-rigid spring material. For example, a sheet of plastic material, such as polycarbonate, may be used. Alternatively, metals, composites, or other types of materials may be used. One of ordinary skill in the art will know and appreciate that any number of other materials may be used, to form leaf spring **52**, so long as the materials have sufficient stiffness and/or resiliency to adequately absorb forces that are transmitted through the wall portion to the portable computer. Leaf spring **52** may include one or more reinforcing channels **58** to increase its impact-absorbing qualities, while at the same time reducing its weight. Preferably, reinforcing channels **58** are oriented substantially longitudinally with respect to leaf spring **52**.

[0019] Shock absorber **50** may also include foam padding that surrounds at least a portion of the leaf spring **52**. In some instances, the foam padding may serve to displace any impact forces that are not absorbed by leaf spring **52**, such as, for example, forces that are transmitted at an acute angle with respect to leaf spring **52**. In the exemplary embodiment of shock absorber **50** shown in FIG. 3, a first layer of padding **54** substantially conforms to the upper, or first, surface of leaf spring **52**, and a second layer of padding **56** substantially conforms to the lower, or second, surface of leaf spring **52**. As shown, first layer **54** and second layer **56** give shock absorber **50** a box-like shape. One of ordinary skill in the art will know and appreciate that any number of layers of padding—having various shapes and/or sizes—may be used and are within the scope of the present invention. One of ordinary skill in the art will also know and appreciate that shock absorber **50** may comprise a single item, such as leaf spring **52**, or multiple items, such as leaf spring **52** and one or more layers of foam padding. Open cell foam, closed cell foam, cross-link foam, or any other type of padding known in the art may be used to form the layers of padding **54**, **56**.

[0020] Referring to FIG. 5, a second exemplary embodiment of a leaf spring according to the present invention is

shown as reference number **252**. According to this embodiment, leaf spring **252** has a curved, generally “W”-shaped cross-section **260** that extends along its length. The generally “W”-shaped cross-section **260** defines a central surface **262**, and side surfaces **264**, **266**. In this embodiment, the portable computer rests between side surfaces **264**, **266**, and atop central surface **262**. Impact forces transmitted through the wall portion of case **10** are at least partially absorbed by leaf spring **252** as central surface **262** deflects downward (in direction “X” shown in FIG. 5) and the side surfaces **264**, **266** deflect outward (along the axis “Y” shown in FIG. 5).

[0021] Referring to FIG. 6, a third exemplary embodiment of a leaf spring according to the present invention is shown as reference number **352**. According to this embodiment, leaf spring **352** has a generally “U”-shaped cross-section **360** that defines a top surface **362** and side surfaces **364**, **366**. In this embodiment, the portable computer rests on top surface **362**, and impact forces transmitted through the wall portion of case **10** are at least partially absorbed by leaf spring **352** as top surface **362** deflects downward (in direction “X” shown in FIG. 6) and the side surfaces **364**, **366** deflect outward (along the axis “Y” shown in FIG. 6). One of ordinary skill in the art will know and appreciate that leaf spring **52**, **252**, **352** is not to be limited to the shapes and/or cross-sections shown herein, and may have any shape, size, or cross-section known in the art, so long as leaf spring **52**, **252**, **352** absorbs at least a portion of any impact forces transmitted through the wall portion of case **10**.

[0022] A carrying case made in accordance with the above-described invention was loaded with a conventional “laptop” computer and dropped several times onto its bottom wall **42** from approximately 40 inches above the ground. The deceleration forces transmitted to the laptop computer were measured for each drop. The average deceleration forces transmitted to the laptop computer were approximately 30 g’s (or 30 times the force of gravity), versus conventional carrying cases which may transmit a force of well over 100 g’s to the computer.

[0023] While various descriptions of the present invention are described above, it should be understood that the various features can be used singly or in any combination thereof. In particular, the various inventive concepts need not be used in conjunction and only one of the inventive concepts may be provided without detracting from the invention. Therefore, this invention is not to be limited to only the specific embodiments depicted herein.

[0024] Further, it should be understood that variations and modifications within the spirit and scope of the invention may occur to those skilled in the art to which the invention pertains. For example, while the carrying case has been described as a case for a portable computer, it may alternatively be sized and dimensioned for carrying any number of different portable electronic devices, such as calculators, personal digital assistants, printers, or scanners. Also, while the carrying case has been shown in the form of a brief case, it may alternatively be in the form of a backpack, as shown in FIG. 7, or any other type of carrying case known in the art. Accordingly, all expedient modifications readily attainable by one versed in the art from the disclosure set forth herein that are within the scope and spirit of the present invention are to be included as further embodiments of the present invention. The scope of the present invention is accordingly defined as set forth in the appended claims.

What is claimed:

1. A carrying case for a portable electronic device comprising:

a plurality of wall portions defining a compartment for receiving the portable electronic device; and

a shock absorber associated with at least one of the wall portions, the shock absorber including a leaf spring;

wherein the leaf spring is configured and dimensioned to absorb at least a portion of any forces transmitted through the wall portion to the portable electronic device.

2. The carrying case of claim 1, wherein the leaf spring is a semi-rigid spring material.

3. The carrying case of claim 1, wherein the leaf spring extends along a substantial portion of the wall portion.

4. The carrying case of claim 1, wherein the wall portion extends from a first corner to a second corner, and the leaf spring extends substantially from the first corner to the second corner.

5. The carrying case of claim 4, wherein the leaf spring is substantially adjacent the wall portion only at the first corner and the second corner, and the leaf spring is spaced apart from the wall portion at points between the first corner and the second corner.

6. The carrying case of claim 5, wherein the leaf spring extends along an arcuate path between the first corner and the second corner.

7. The carrying case of claim 1, wherein the shock absorber further includes foam padding surrounding at least a portion of the leaf spring.

8. The carrying case of claim 7, wherein the leaf spring has first and second surfaces substantially opposed to one another, and the foam padding substantially conforms to at least one of the first and second surfaces.

9. The carrying case of claim 8, wherein the shock absorber includes a first layer of foam padding substantially conforming to the first surface, and a second layer of foam padding substantially conforming to the second surface.

10. The carrying case of claim 9, wherein the first and second layers of foam padding define a substantially boxed shape of the shock absorber.

11. The carrying case of claim 7, wherein the foam padding is an open-cell foam.

12. The carrying case of claim 1, wherein the leaf spring includes at least one reinforcing channel extending substantially longitudinally along the leaf spring.

13. The carrying case of claim 1, wherein the leaf spring has a generally "W"-shaped cross-section.

14. The carrying case of claim 1, wherein the leaf spring has a generally "U"-shaped cross-section.

15. The carrying case of claim 1, wherein the leaf spring is plastic.

16. The carrying case of claim 1, wherein the leaf spring is polycarbonate.

17. The carrying case of claim 1, wherein the plurality of wall portions includes a bottom wall configured and dimensioned for resting on the ground, and the shock absorber is associated with the bottom wall.

18. The carrying case of claim 1, further comprising a shoulder strap for hanging the carrying case from a user's shoulder.

19. The carrying case of claim 1, wherein the carrying case is a backpack.

20. The carrying case of claim 1, further comprising a compartment configured and dimensioned to hold a power supply cable for the portable computer.

21. The carrying case of claim 1, further comprising a compartment configured and dimensioned to hold computer accessories.

22. The carrying case of claim 1, wherein at least one of the wall portions is bound by a zipper that allows the compartment to be opened and closed.

23. A carrying case for a portable computer, comprising:

a plurality of walls including a bottom wall configured and dimensioned to rest on the ground;

a compartment located within the carrying case for receiving the portable computer; and

a leaf spring located within the compartment proximate the bottom wall of the carrying case, the leaf spring extending substantially parallel to the bottom wall;

wherein the leaf spring is configured and dimensioned to absorb at least a portion of any forces transmitted from the ground to the portable computer.

24. The carrying case of claim 23, wherein the leaf spring is a semi-rigid spring material.

25. The carrying case of claim 23, wherein the leaf spring extends along a substantial portion of the bottom wall.

26. The carrying case of claim 23, wherein the bottom wall extends from a first corner to a second corner, and the leaf spring extends substantially from the first corner to the second corner.

27. The carrying case of claim 26, wherein the leaf spring is substantially adjacent the bottom wall only at the first corner and the second corner, and the leaf spring is spaced apart from the bottom wall at points between the first corner and the second corner.

28. The carrying case of claim 27, wherein the leaf spring extends along an arcuate path between the first corner and the second corner.

29. The carrying case of claim 23, further including foam padding surrounding at least a portion of the leaf spring.

30. The carrying case of claim 29, wherein the foam padding is an open-cell foam.

31. The carrying case of claim 29, wherein the foam conforms to the leaf spring and defines a substantially box shape around the leaf spring.

32. The carrying case of claim 23, wherein the leaf spring includes at least one reinforcing channel extending substantially longitudinally along the leaf spring.

33. The carrying case of claim 23, wherein the leaf spring is a semi-rigid spring material.

34. The carrying case of claim 23, wherein the leaf spring is polycarbonate.

35. The carrying case of claim 23, further comprising a shoulder strap for hanging the carrying case from a user's shoulder.

36. The carrying case of claim 23, wherein the carrying case is a backpack.

37. The carrying case of claim 23, further comprising a compartment configured and dimensioned to hold a power supply cable for the portable computer.

38. The carrying case of claim 23, further comprising a compartment configured and dimensioned to hold computer accessories.

39. The carrying case of claim 23, wherein the compartment further comprises an opening extending through one of

the exterior walls of the carrying case, the opening configured and dimensioned for passage of the portable computer therethrough.

* * * * *